

TID No. 7031

TO: Mr R Stubbington LAS IPT

DATE: 21<sup>st</sup> July 2008

TASK: 36046

**CERTIFICATE OF CONFORMANCE****FOR****CARRIER PERSONNEL FULL TRACKED FV 432 MK 2 & 2/1  
& FV 434 MK 1 & 1/1**

**PUBLICATION NUMBER:** 2350-T-251-201  
**TITLE:** Operating Information  
**AMENDMENT/STATUS:** 2  
**CHAPTER(S):** Various

It is certified that the AESP listed above, presented as a Portable Document Format (PDF) master on Compact Disk (CD) is approved for issue in that:

- a) It incorporates all necessary Safety Precautions and Warnings.
- b) It incorporates all agreed comments and amendments requested by the MoD and BAE.
- c)
- d)

Signed.....

Date.....21/7/08.....

**For BAE Systems Land Systems****Note:**

This certificate is to be signed by the Design Engineer or a nominated authorised representative.

TID No. 7110

TO: Mr R Stubbington LAS IPT

DATE: 12<sup>th</sup> August 2008

TASK: 36034

**CERTIFICATE OF CONFORMANCE**

FOR

**CARRIER PERSONNEL FULL TRACKED FV 432 MK 2 &  
2/1 & FV 434 MK 1 & 1/1**

**PUBLICATION NUMBER:** 2350-T-251  
**TITLE:** All Categories  
**AMENDMENT/STATUS:** Various  
**CHAPTER(S):** Various

It is certified that the AESP listed above, presented as a Portable Document Format (PDF) master on Compact Disk (CD) is approved for issue in that:

*(Add applicable wording)*

- a) It incorporates all necessary Safety Precautions and Warnings.
- b) It incorporates all agreed comments and amendments requested by the MoD and BAE.
- c)
- d)

Signed..... *Y. P. Short* .....Date..... *12th August 2008* .....

For BAE Systems Land Systems

**Note:**

This certificate is to be signed by the Design Engineer or a nominated authorised representative.

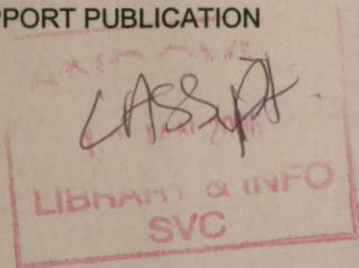

030714



**CONDITIONS OF RELEASE**

- 1 This information is released by the UK Government for defence purposes only.
- 2 This information must be afforded the same degree of protection as that afforded to information of an equivalent security marking originated by the recipient Government or as required by the recipient Government's security regulations.
- 3 This information may be disclosed only within the Defence Department of the recipient Government, except as otherwise authorized by the Ministry of Defence (Army).
- 4 This information may be subject to privately owned rights.

# **CARRIER PERSONNEL FULL TRACKED FV432 MK 2 & 2/1 (BOWMAN)**

## **OPERATING INFORMATION**

THIS DOCUMENT IS THE PROPERTY OF HER BRITANNIC MAJESTY'S GOVERNMENT, and issued for the information of such persons only as need to know its contents in the course of their official duties. Any person finding this document should hand it into a British forces unit or to a police station for its safe return to the MINISTRY OF DEFENCE, (DSy (Pol)), MAIN BUILDING, WHITEHALL, LONDON, SW1A 2HB, with particulars of how and where found. THE UNAUTHORIZED RETENTION OR DESTRUCTION OF THE DOCUMENT IS AN OFFENCE UNDER THE OFFICIAL SECRETS ACTS OF 1911-1989. (When released to persons outside Government service, this document is issued on a personal basis and the recipient to whom it is entrusted in confidence, within the provisions of the Official Secrets Acts 1911-1989, is personally responsible for its safe custody and for seeing that its contents are disclosed only to authorized persons).

**BY COMMAND OF THE DEFENCE COUNCIL**

Ministry of Defence  
Issued by

**DEFENCE LOGISTICS ORGANISATION**

AMENDMENT RECORD

Amdt No.	Incorporated by (Signature)	Date
1		11/06
2		
3		
4		
5		
6		
7		
8		
9		
10		
11		
12		
13		
14		
15		
16		
17		
18		
19		
20		
21		
22		
23		
24		
25		
26		
27		
28		
29		
30		
31		

Amdt No.	Incorporated by (Signature)	Date
32		
33		
34		
35		
36		
37		
38		
39		
40		
41		
42		
43		
44		
45		
46		
47		
48		
49		
50		
51		
52		
53		
54		
55		
56		
57		
58		
59		
60		
61		
62		

~~UNRESTRICTED~~

~~UNRESTRICTED~~

**CONTENTS**

**PRELIMINARY MATERIAL**

	Page
Front cover (title page).....	(i)/(ii)
Amendment record .....	(iii)/(iv)
CONTENTS (this list).....	(v)
PREFACE .....	(vi)
Introduction .....	(vi)
Related and Associated Publication .....	(vi)
Related Publications.....	(vii)
Associated Publications.....	(viii)
Abbreviations .....	(viii)
Warnings .....	(viii)
Cautions .....	(xii)
Comment(s) on AESP.....	Final leaf

**OPERATING INFORMATION**

Chap

- 1-0 General
- 2-0 Vehicle Systems
- 3-0 Special to role equipment
- 4 Destruction of Equipment

**PREFACE**

Sponsor: LASS IPT DLO Andover

File Ref: 13062

Publication Agency:

Project No:

**INTRODUCTION**

1 Service users should forward any comments concerning this Publication through the channels prescribed in AESP 0100-P-011-013. An AESP Form 10 is provided at the end of this document; it should be photocopied and used for forwarding comments on this AESP.

2 AESPs are issued under Defence Council authority and where AESPs specify action to be taken, the AESP will of itself be sufficient authority for such action and also for the demanding of the necessary stores, subject to the provision of Para 3 below.

3 The subject matter of this publication may be affected by Defence Council Instructions (DCIs), Standard Operating Procedures (SOPs) or by local regulations. When any such instruction, order or regulation contradicts any portion of this publication it is to be taken as the overriding authority.

**RELATED AND ASSOCIATED PUBLICATIONS****Related Publications**

4 The Octad for the subject equipment consists of the Publications shown below. All references are prefixed with the first eight digits of this Publication. The availability of the publications can be checked by reference to the relevant Group Index (see AESP 0100-A-001-013).

5 This publication has been produced in both hard copy and microfiche formats.

6 AESP 2350-T-250-601 Maintenance Schedule, also contains references to all oils and greases used within those schedules.

## CONTENTS

### PRELIMINARY MATERIAL

	Page
Front cover (title page).....	(i)/(ii)
Amendment record .....	(iii)/(iv)
CONTENTS (this list).....	(v)
PREFACE .....	(vi)
Introduction .....	(vi)
Related and Associated Publication .....	(vi)
Related Publications.....	(vii)
Associated Publications.....	(viii)
Abbreviations .....	(viii)
Warnings .....	(viii)
Cautions .....	(xiii)/(xiv)
Comment(s) on AESP.....	Final leaf

### OPERATING INFORMATION

#### Chap

- 1-0 General
- 2-0 Vehicle Systems
- 3-0 Special to role equipment
- 4 Destruction of Equipment



**PREFACE**

Sponsor: LASS IPT DLO Andover  
File Ref: 13062  
Publication Agency:  
Project No:

**INTRODUCTION**

1 Service users should forward any comments concerning this Publication through the channels prescribed in AESP 0100-P-011-013. An AESP Form 10 is provided at the end of this document; it should be photocopied and used for forwarding comments on this AESP.

2 AESPs are issued under Defence Council authority and where AESPs specify action to be taken, the AESP will of itself be sufficient authority for such action and also for the demanding of the necessary stores, subject to the provision of Para 3 below.

3 The subject matter of this publication may be affected by Defence Council Instructions (DCIs), Standard Operating Procedures (SOPs) or by local regulations. When any such instruction, order or regulation contradicts any portion of this publication it is to be taken as the overriding authority.

**RELATED AND ASSOCIATED PUBLICATIONS****Related Publications**

4 The Octad for the subject equipment consists of the Publications shown below. All references are prefixed with the first eight digits of this Publication. The availability of the publications can be checked by reference to the relevant Group Index (see AESP 0100-A-001-013).

5 This publication has been produced in both hard copy and microfiche formats.

6 AESP 2350-T-250-601 Maintenance Schedule, also contains references to all oils and greases used within those schedules.

Category/Sub-category			Information level			
			1 User/ Operator	2 Unit Maintenance	3 Field Maintenance	4 Base Maintenance
1	0	Purpose and Planning Information	101	101	101	101
	1	Equipment Support Policy Directives	*	*	*	*
2	0	Operating Information	*	*	*	*
	1	Aid Memoire	*	*	*	*
	2	Training Aids	221	*	*	*
3		Technical Description	201	302	302	302
4	1	Installation Instructions	*	412	*	*
	2	Preparation for Special Environments	*	*	*	*
5	1	Failure Diagnosis	201	512	523	*
	2	Maintenance Instructions	201	522	523	524
	3	Inspection Standards	*	532	533	534
	4	Calibration Standards	*	*	*	*
6		Maintenance Schedules (Army)	*	*	*	*
7	1	Illustrated Parts Catalogues	711	711	711	711
	2	Commercial Parts Lists	*	*	*	*
	3	Complete Equipment Schedule, Production	*	*	*	*
	4	Complete Equipment Schedule, Service Edition (Simple Equipment)	741	741	741	741
	5	Complete Equipment Schedule, Service Edition (Complex Equipment)	*	*	*	*
8	1	Modification Instructions	811	811	811	811
	2	General Instructions, Special Technical Instructions and Servicing Instructions	821	821	821	821
	3	Service Engineered Modification Instructions (RAF only)	*	*	*	*

\* Categories/Sub-categories not published

**Associated Publications**

7 The following publications should be read in conjunction with this publication:

<u>Reference</u>	<u>Title</u>
AESP 0200-A-100	Equipment Care Inspection and Mandatory Equipment Inspection
AESP 0200-A-190	Engineering Hygiene in the Field
AESP 1015-C-100	Equipment 81 mm Mortar
AESP 5680-C-100	Pipe Fascine, Mini
AESP 6140-A-100-013	Secondary batteries lead-acid
AESP 6920-D-100-101	Direct fire weapon effect simulator family (DFWES)
AESP 6920-D-101-201	Attack and target weapon effects simulator (ATWES/TAGWES)
AESP 6920-D-102-201	Target weapon effects simulator (TAGWES)
AESP 6920-D-210-211	TAGWES on fighting vehicle FV432 and fighting vehicle FV434
Army Code 63723	Health and Safety in Management in ESO/REME
Army Code 64193	Warning card for Steering and Braking
Army Code 71276	All Arms Standing Orders for the Safety of Crews of AFV's
Army Code 71576	Unit Equipment Care Guide
IETP (TBA)	Bowman radio publications

**ABBREVIATIONS**

8 Throughout this Publication, any reference to right or left is seen as from the rear of the vehicle looking forward, unless otherwise stated. Where non-standard abbreviations are used, the full meaning is written out the first time the subject is mentioned in text followed by the abbreviation in brackets.

**WARNINGS**

- (1) **PERSONNEL INJURY. DUE TO THE DIFFERING VARIANTS OF THE FV430 SERIES THE EVACUATION DRILLS WILL CHANGE FROM VARIANT TO VARIANT. BEFORE USE, ADVICE FOR EVACUATION DRILLS SHOULD BE SOUGHT FROM THE U.E.M. (UNIT EQUIPMENT MANAGER)**
- (2) **PERSONNEL INJURY. WHERE ROOF MOUNTED EQUIPMENT PREVENTS THE R//H MORTAR HATCH BEING OPENED, A RESTRICTION OF FOUR (4) PERSONNEL MAXIMUM CAN BE TRANSPORTED IN THE REAR OF THE VEHICLE.**
- (3) **SAFETY HAZARD. IF VEHICLE IS ON AN UPWARD SLOPE, RELEASING THE REAR DOOR CATCH WILL ALLOW THE REAR DOOR TO SWING OPEN UNCONTROLLABLY WITH POSSIBLE SERIOUS RESULTS.**
- (4) **PERSONNEL SAFETY. IN THE EVENT OF A FIRE ENSURE ALL PERSONNEL HAVE BEEN EVACUATED FROM THE VEHICLE AND THAT ALL NON-ESSENTIAL PERSONNEL HAVE BEEN EVACUATED TO A SAFE AREA.**
- (5) **ASPHYXIATION HAZARD. THIS EQUIPMENT CONTAINS A HECTOFLUOROPROPANE (FM 200) FIRE SUPPRESSED SYSTEM. IF FM 200 VAPOUR IS BREATHED, IT CAN CAUSE SUFFOCATION. ONLY TRAINED PERSONNEL UNDER SUPERVISION ARE ALLOWED TO WORK ON THE SYSTEM. ANYONE WHO HAS BREATHED FM 200 VAPOUR IS TO RECEIVE MEDICAL ATTENTION.**
- (6) **ASPHYXIATION HAZARD. THE VAPOURS OF ALL FIRE EXTINGUISHERS DISPLACE AIR AND CAN CAUSE ASPHYXIA IN CONFINED SPACES. OPEN ALL HATCHES AND ALLOW TIME FOR FUMES TO DISPERSE BEFORE PERSONNEL RE-ENTER THE VEHICLE.**

- (7) **ASPHYXIATION HAZARD.** DRY POWDER EXTINGUISHERS ARE NON-TOXIC. HOWEVER, THIS TYPE OF EXTINGUISHER IS NOT TO BE USED IN A CONFINED SPACE UNLESS IN AN EXTREME EMERGENCY.
- (8) **EQUIPMENT DAMAGE.** DO NOT STAND ON THE FORWARD LEFT SEAT WHEN THE VENTILATION BATTERIES HAVE BEEN TURNED OR REMOVED AS THE SEAT COULD COLLAPSE.
- (9) **HEAVY WEIGHT.** USE EXTREME CAUTION AND ENSURE THAT THE CURRENT REGULATIONS GOVERNING THE LIFTING AND LOWERING OF HEAVY WEIGHTS ARE OBSERVED WHENEVER A STEERING UNIT ACCESS COVER IS OPENED OR CLOSED.
- (10) **PERSONNEL DANGER.** FATAL OR SERIOUS INJURY CAN OCCUR IF A SMOKE GRENADE DISCHARGES DURING THE LOADING PROCEDURE. ENSURE THE SMOKE DISCHARGER SWITCH IS IN THE OFF POSITION AND THAT ALL NON-ESSENTIAL PERSONNEL ARE CLEAR OF THE AREA TO A DISTANCE OF 200 METRES.
- (11) **SAFETY HAZARD.** RADIO TRANSMISSION, DURING THE LOADING PROCEDURE, CAN CAUSE SMOKE GRENADES TO DISCHARGE. ENSURE NO TRANSMISSION TAKES PLACE DURING THE LOADING PROCEDURE.
- (12) **PERSONAL INJURY.** KEEP OUT OF THE LINE OF FIRE OF DISCHARGER BARRELS WHEN LOADING OR UNLOADING SMOKE GRENADES.
- (13) **PERSONNEL DANGER.** FATAL OR SERIOUS INJURY CAN OCCUR IF A SMOKE GRENADE DISCHARGES DURING THE LOADING PROCEDURE. ENSURE THE SMOKE DISCHARGER SWITCH IS IN THE OFF POSITION AND THAT ALL NON-ESSENTIAL PERSONNEL ARE CLEAR OF THE AREA TO A DISTANCE OF 200 METRES.
- (14) **SAFETY HAZARD.** RADIO TRANSMISSION, DURING THE UNLOADING PROCEDURE, CAN CAUSE SMOKE GRENADES TO DISCHARGE. ENSURE NO TRANSMISSION TAKES PLACE DURING THE UNLOADING PROCEDURE.
- (15) **FIRE HAZARD.** A RISK OF FIRE AND/OR EXPLOSION EXISTS WHEN FUEL IS BEING TRANSFERRED FROM ONE CONTAINER TO ANOTHER AT A POINT IN CLOSE PROXIMITY TO A RADAR SET. DO NOT TRANSFER FUEL WHEN A RADAR SET IS IN OPERATION. SAFE DISTANCE WILL VARY, DEPENDANT UPON RADAR SET FORM 2 TO 275 METRES.
- (16) **FIRE HAZARD.** A RISK OF FIRE AND/OR EXPLOSION EXISTS WHEN FUEL IS BEING TRANSFERRED FROM ONE CONTAINER TO ANOTHER AT A POINT IN CLOSE PROXIMITY TO HF RADIO TRANSMISSION. REFUELLING SHOULD NOT TAKE PLACE WHILST TRANSMITTING OR IF IN CLOSE PROXIMITY TO ANOTHER VEHICLE, WHICH IS TRANSMITTING.
- (17) **PERSONAL INJURY.** THE NO SMOKING OR NAKED LIGHT REGULATIONS MUST BE FOLLOWED WHENEVER FUEL IS BEING TRANSFERRED OR WHEN ANY PART OF THE FUEL SYSTEM IS OPEN.
- (18) **ENVIRONMENTAL HAZARD.** DO NOT DRAIN THE FLUID CONTENTS OF THE HULL ONTO THE GROUND. SUITABLE CONTAINERS SHOULD BE USED TO COLLECT THE DRAINED FLUIDS
- (19) **VEHICLE MOVEMENT.** THE DRIVER SHOULD NOT LEAVE THE VEHICLE WHEN THE ENGINE IS RUNNING UNLESS THEIR OWN SAFETY IS ENDANGERED.
- (20) **PERSONAL INJURY.** CARE MUST BE TAKEN WHEN DRAINING OILS FROM POWER PACK. THE ENGINE OIL COULD BE HOT AND A DANGER OF SCALDING IS POSSIBLE.

- (21) **PERSONAL INJURY.** DO NOT REMOVE THE COOLANT FILLER CAP WHILE THE ENGINE IS RUNNING. ALWAYS WAIT UNTIL THE TEMPERATURE IS BELOW 93 deg C (200 deg F) BEFORE REMOVING THE COOLANT FILLER CAP OR SEVERE SCALDING MAY RESULT.
- (22) **TOXIC HAZARD.** ANTI-FREEZE IS BOTH TOXIC AND HAZARDOUS. MINIMUM PRECAUTION AFTER USE IS TO WASH THE AFFECTED SKIN AREAS WITH SOAP AND WATER.
- (23) **HEAVY WEIGHT.** THE POWER PACK ACCESS COVER IS EXTREMELY HEAVY. WHEN LIFTING/OPENING THE ACCESS COVERS CONSIDERATION SHOULD BE GIVEN TO THE REGULATIONS GOVERNING THE LIFTING OF HEAVY WEIGHTS.
- (24) **SAFETY HAZARD.** BEFORE PERSONNEL ARE ALLOWED UNDER THE VEHICLE, THE STEERING/PARKING BRAKE MUST BE FULLY APPLIED, THE ENGINE STOPPED AND THE VEHICLE SECURED TO PREVENT MOVEMENT.
- (25) **SAFETY HAZARD.** BEFORE PERSONNEL ARE ALLOWED UNDER THE VEHICLE AND LOCATING THE JACKING MANDREL, THE STEERING/PARKING BRAKE MUST BE FULLY APPLIED, THE ENGINE STOPPED AND THE VEHICLE SECURED TO PREVENT MOVEMENT.
- (26) **PHYSICAL INJURY.** ENSURE THAT THE VEHICLE IS IN NEUTRAL AND THE PARKING BRAKE IS APPLIED BEFORE CLIMBING UNDER THE VEHICLE AND LOCATING THE JACKING STRUT. ENSURE THE TOOL IS CLEAN. NO PERSON IS TO REMAIN UNDER THE VEHICLE WHEN VEHICLE IS BEING MOVED TO LIFT WHEEL STATION.
- (27) **SAFETY HAZARD.** PERSONNEL INSPECTING TRACKS MUST REMAIN IN SIGHT OF THE COMMANDER. THEY ARE NOT TO STAND BEHIND THE VEHICLE WHILST IT IS IN MOTION. THEY ARE TO RETAIN VISUAL CONTACT WITH THE COMMANDER. THEY ARE NOT TO MAKE PHYSICAL CONTACT WITH ANY PART OF THE TRACK AND RUNNING GEAR WHILST THE VEHICLE IS IN MOTION.
- (28) **SAFETY HAZARD.** THE COMMANDER MUST ALWAYS REMAIN IN SIGHT OF THE DRIVER AND MAINTAIN VISUAL CONTACT WITH PERSONNEL INSPECTING THE TRACKS. SHOULD ANY OF THE PERSONNEL DISAPPEAR FROM VIEW OR NOT RESPOND TO HIS COMMANDS HE IS TO IMMEDIATELY INSTRUCT THE DRIVER TO HALT THE VEHICLE.
- (29) **SAFETY HAZARD.** THE DRIVER MUST HALT THE VEHICLE IF THE COMMANDER GOES OUT OF HIS SIGHT.
- (30) **SAFETY HAZARD.** IT IS NOT SAFE PRACTICE TO HAVE BOTH TRACKS REMOVED AT THE SAME TIME, AS NO VEHICLE BRAKING IS AVAILABLE. IF TWO TRACK REMOVALS IS UNAVOIDABLE SECURE THE VEHICLE BY CHOCKING THE ROAD WHEELS BEFORE SPLITTING THE SECOND TRACK.
- (31) **PERSONAL INJURY.** IT IS ESSENTIAL THAT THE TRACK IS REMOVED UNDER CONTROL USING TRACK REMOVAL TOOLS
- (32) **PERSONNEL HAZARD.** THE VOLTAGES USED ON SOME OF THE EQUIPMENT ON THE VEHICLE, E.G. RADIOS, CAN BE LETHAL. DO NOT TAMPER WITH THESE EQUIPMENTS OR ATTEMPT ANY REPAIR OR ADJUSTMENT WITH THE BATTERY SWITCHES ON.
- (33) **DAMAGE TO EYESIGHT.** THE INFRA RED (IR) DRIVING LIGHTS ARE FITTED WITH 100 WATT LAMPS. THESE LIGHTS ARE NO LONGER USED. NEVER LOOK AT THE IR LIGHT WHEN THE FILTER IS FITTED AND THE LIGHT IS SWITCHED ON AS SERIOUS AND PERMANENT DAMAGE TO THE EYE MAY RESULT.
- (34) **PERSONAL INJURY.** THE ALTERNATORS GET EXTREMELY HOT WHEN RUNNING.

- (35) **FIRE HAZARD.** THE GASES RELEASED FROM THE BATTERY ARE HIGHLY INFLAMMABLE; THEREFORE, ELECTRICAL CONNECTIONS MUST BE MAINTAINED CLEAN AND TIGHT TO PREVENT IGNITION OF GASES. BEFORE REMOVING OR REPLACING CONNECTORS, PUT THE APPROPRIATE BATTERY SWITCH TO OFF AND ENSURE THAT THE VENT TUBES ARE FITTED TO CELL COVERS. DO NOT ATTEMPT TO REMOVE OR REPLACE THE POSITIVE, WITH THE NEGATIVE (EARTH) CONNECTED. FRESHLY CHARGED BATTERIES MUST NOT BE INSTALLED UNTIL ALL GASSING HAS CEASED. A NAKED LIGHT MUST NEVER BE USED WHEN EXAMINING A BATTERY.
- (36) **LETHAL VOLTAGE.** BEFORE REMOVING OR REPLACING BATTERY CONNECTION, ENSURE THAT THE ENGINE IS STOPPED. SET THE BATTERY SWITCH, LOCATED ON THE DISTRIBUTION PANEL AND RADIO DISTRIBUTION BOX, TO OFF.
- (37) **HEAVY WEIGHT.** EACH BATTERY WEIGHS APPROXIMATELY 38Kg (84 lb).
- (38) **LETHAL VOLTAGE.** WHEN DISCONNECTING BATTERIES, REMOVE ALL THE TERMINALS FROM THE EARTH (NEGATIVE) (-) TERMINAL POSTS BEFORE REMOVING THE SUPPLY (POSITIVE) (+) TERMINALS. REPLACE IN THE REVERSE ORDER (POSITIVE TERMINALS FIRST).
- (39) **HEAVY WEIGHT.** EACH BATTERY WEIGHS 38 KG (84 LB). DUE CONSIDERATION MUST BE GIVEN TO THE REGULATIONS GOVERNING THE LIFTING OF HEAVY WEIGHTS WHEN MOVING EQUIPMENT.
- (40) **PERSONAL INJURY.** THE ACID IN THE CELLS IS HARMFUL AND MUST NOT BE ALLOWED TO CONTACT THE EYES, SKIN OR CLOTHING.
- (41) **PERSONAL INJURY.** TO AVOID CANS PRESSURISING IT IS ESSENTIAL WHEN HEATING COMPO RATIONS UNDECANTED THAT THE TOPS OF THE CANS ARE PIERCED AND THAT THE TINS ARE NOT TO BE PLACED ONE ON TOP OF THE OTHER.
- (42) **PERSONNEL INJURY.** DEEP FRYING MUST NOT BE ATTEMPTED. THE OIL/FAT COULD BOIL OVER AND A SERIOUS FIRE OR INJURY RESULT
- (43) **PERSONNEL INJURY.** THE BASE OF THE WATER COMPARTMENT BECOMES RED HOT WHEN FRYING, DO NOT ATTEMPT TO COOL BY POURING WATER INTO THE COMPARTMENT. SERIOUS SCALDING MAY RESULT.
- (44) **PERSONNEL INJURY.** CARE MUST BE TAKEN WHEN REFILLING WITH WATER SOON AFTER FRYING. SERIOUS SCALDING MAY RESULT.
- (45) **PERSONAL INJURY.** PETROL OR OIL DERIVATIVES MUST NOT BE USED UNDER ANY CIRCUMSTANCES. THEY CAUSE SILICONE SEALS TO SWELL AND SEALS THAT HAVE SWOLLEN ARE TOXIC. ANY SEAL THAT HAS BECOME CONTAMINATED MUST BE CHANGED BEFORE THE VESSEL IS AGAIN USED.
- (46) **PERSONNEL INJURY.** WHEN TOW STARTING WITH A CHAIN, WIRE ROPE OR KINETIC ENERGY ROPE, BOTH DRIVER AND COMMANDER MUST BE CLOSED DOWN. ONCE THE VEHICLE HAS STARTED, THE VEHICLE IS TO BE HALTED IN A SAFE PLACE AND THE TOWING EQUIPMENT DISCONNECTED
- (47) **ROAD SAFETY HAZARD.** DEPRESSING THE ACCELERATOR FULLY TOO RAPIDLY CAN CAUSE A DOWN CHANGE AND RELEASING IT QUICKLY, AN UP CHANGE. THE CONTINUAL EMPLOYMENT OF THIS TYPE OF DRIVING AND CAN BE DANGEROUS WHEN DRIVING IN TRAFFIC.

(48) **EQUIPMENT DAMAGE.** PROLONGED APPLICATION OF THE STEERING/BRAKE LEVERS COULD LEAD TO OVERHEATING OF THE STEERING/BRAKE SYSTEM, WHICH COULD CAUSE PREMATURE FAILURE.

(49) **SAFETY HAZARD.** IF THE ADJUSTMENT DESCRIBED IN PARA 20 IS INCORRECT THE FAULT MUST BE REPORTED TO REME IMMEDIATELY.

(50) **PERSONAL INJURY.** WHEN TOWING WITH A CHAIN, WIRE ROPE OR KINETIC ENERGY ROPE, BOTH DRIVER AND COMMANDER'S HATCHES MUST BE CLOSED DOWN.

(51) **RADIOACTIVE GAS.** THE VEHICLE LEVEL INDICATORS CONTAIN TRILUX LAMPS. WHEN A LAMP IS BROKEN A SMALL QUANTITY OF RADIOACTIVE TRITIUM GAS IS RELEASED. IF A LAMP IS BROKEN, VACATE THE VEHICLE IMMEDIATELY. IN CONFINED SPACES, DOORS AND WINDOWS SHOULD BE OPENED. ALLOW 30 MINUTES FOR THE TRITIUM GAS TO DISPERSE. DO NOT HANDLE BROKEN LAMP PARTS. ENSURE NO ONE BREATHE IN CONTAMINATED AIR.

(52) **TRILUX LAMPS.** THE SCALES AND BUBBLES OF THE SIGHT CONTAIN TRILUX LAMPS. IF A LAMP IS BROKEN A SMALL QUANTITY OF RADIO ACTIVE TRITIUM GAS IS RELEASED. IF A LAMP IS BROKEN INSIDE THE VEHICLE, VACATE THE VEHICLE IMMEDIATELY; VENTILATE THE VEHICLE FOR 30 MINUTES. ENSURE THAT NO ONE BREATHE IN CONTAMINATED AIR.

(53) **FIRE HAZARD.** DUE CONSIDERATION SHOULD BE GIVEN TO THE HIGHLY FLAMMABLE NATURE OF GASOLINE AND ITS VAPOUR. CARELESSNESS IN ITS USE MAY RESULT IN PAINFUL BURNS.

(54) **PERSONNEL HAZARD.** FIRING ARTILLERY AT RANGES OF 500 METRES OR LESS AND FIRING RIFLE GRENADES OR ANTI-TANK ROCKETS SHOULD BE FROM COVER.

(55) **PERSONNEL HAZARD.** ENSURE THAT ALL LOCAL STANDING OPERATING PROCEDURES AND ALL CURRENT HEALTH AND SAFETY REGULATIONS ARE COMPLIED WITH, WHEN CARRYING OUT ANY OF THE PROCEDURES DETAILED WITHIN THIS PUBLICATION.

(56) **PERSONNEL HAZARD.** BEFORE USING ANY HAZARDOUS SUBSTANCE OR MATERIAL, ENSURE THAT YOU KNOW THE SAFETY AND FIRST AID INSTRUCTIONS:

(56.1) ON THE LABEL OF THE CONTAINER IT WAS SUPPLIED IN.

(56.2) ON THE MATERIAL SAFETY DATA SHEET.

(56.3) IN THE LOCAL SAFETY ORDERS AND REGULATIONS.

(57) **LETHAL VOLTAGES.** DANGEROUS VOLTAGES EXIST IN THIS EQUIPMENT. WHEN CARRYING OUT WORK ON ANY BOWMAN RADIO EQUIPMENT DURING FAILURE DIAGNOSTICS, REFER TO EMER MGMT S-262

(58) **FIRE HAZARD.** BOWMAN EQUIPMENT MAY CAUSE FLAMMABLE SUBSTANCES TO IGNITE AT REFUELLING POINT. BOWMAN SYSTEM MUST BE TURNED TO STANDBY DURING REFUELLING

(59) **PERSONNEL INJURY.** BOWMAN ANTENNAS MAY TRANSMIT AT ANY TIME. SHOULD A CREW MEMBER GRAB AN ANTENNA WHILST TRANSMITTING THEY MAY SUFFER RF BURNS. UNDER NO CIRCUMSTANCES MUST AN ANTENNA BE TOUCHED WHEN FITTED TO THE VEHICLE UNLESS EQUIPMENT IS TURNED TO STANDBY.

(60) PERSONNEL INJURY. CARE MUST BE TAKEN WHILST MOVING THE VEHICLE WITH THE ANTENNAS FITTED. TOUCHING OF OVERHEAD CABLES MAY INDUCE HIGH VOLTAGES INTO THE VEHICLE CAUSING POSSIBLE ELECTROCUTION OF CREW MEMBERS.

(61) PERSONNEL INJURY. WHEN CARRYING OUT ANY TYPE WORK ON THE FV432 (BOWMAN) VEHICLE ATTENTION MUST BE MADE TO THE VARIOUS SAFETY NOTICES WHICH ARE POSITIONED THROUGHOUT THE VEHICLE.

(62) PERSONAL INJURY. ALL USERS AND MAINTAINERS MUST PAY ATTENTION TO THE BOWMAN SAFETY NOTICES AS ISSUED BY BOWMAN LAND DIGITIZATION (BLD) TO UNITS.

## CAUTIONS

- (1) SMOKE SOURCE. Before operating a fire extinguisher, consideration should be given to the possible cause of smoke. Allowance should be made for smoke from surplus oil, new engine paintwork, new insulation on the exhaust system and any other normal vapour.
- (2) EQUIPMENT DAMAGE. The glass surfaces must be kept absolutely clean; they must not be touched directly with the fingers.
- (3) EQUIPMENT DAMAGE. Report immediately any signs of distortion or defects, which might impair the air seal. This is essential to prevent overheating power pack components.
- (4) EQUIPMENT DAMAGE. The engine must not be run with the automotive batteries disconnected.
- (5) EQUIPMENT DAMAGE. If the roof basket is fitted, only the right hand mortar hatch can be opened. The roof basket must be removed before the left hand mortar hatch can be opened.
- (6) EQUIPMENT DAMAGE. To prevent damage to the engine fans, ensure the spent case bins are emptied at the specified intervals
- (7) EQUIPMENT DAMAGE. Coolant may collect on top of the baffle plate so that at a glance a false impression of the level can be given.
- (8) EQUIPMENT DAMAGE. If for any reason the wheel nuts have been slackened and re-tightened, they must be checked for tightness daily for the next three days that the vehicle is operated. The wheel nuts must be tightened by one man using the torque wrench supplied for this purpose. Pipes, bars etc must not be used to increase the leverage, as the torque must not exceed 163 nm (120 lb/ft).
- (9) EQUIPMENT DAMAGE. Vehicle damage may occur if the track is not restrained during the removal procedure.
- (10) EQUIPMENT DAMAGE. Always stand the filter on the brass plug head; never place it on its side, especially on steel or iron as this may cause loss of magnetism.
- (11) EQUIPMENT DAMAGE. When working in sub-zero conditions the batteries must be kept fully charged, otherwise the electrolyte may freeze. For further maintenance, reference should be made to the appropriate AESP listed under Associated Publications.
- (12) EQUIPMENT DAMAGE. Each pair of batteries must be of the same type, (i.e. both maintenance free)
- (13) EQUIPMENT DAMAGE. Connection and disconnection of the harness must be made at the boiling vessel by means of the push-on/pull-off connector.



- (14) **EQUIPMENT DAMAGE.** To avoid seriously damaging the electrical element, the inner container must be in place within the vessel when boiling less than 1.14 litres (2 pints) of water.
- (15) **EQUIPMENT DAMAGE.** Do not make coffee, soups etc in the water compartment, as this heavy fluid will cause the drain tap to malfunction.
- (16) **EQUIPMENT DAMAGE.** The vessel must not be stood on a damp surface, especially if the vessel is hot, as moisture can be drawn up into the insulation material.
- (17) **EQUIPMENT DAMAGE.** If the engine is started with the distribution link box warning light illuminated, internal damage to the generating system will result.
- (18) **EQUIPMENT DAMAGE.** Running the engine for long periods with the engine/traverse gearbox dis connector clutch out of engagement may damage the clutch.
- (19) **EQUIPMENT DAMAGE.** The engine must not be run with the automotive batteries disconnected.
- (20) **EQUIPMENT DAMAGE.** Do not re-engage transfer gearbox whilst engine is running as serious equipment damage could occur.
- (21) **EQUIPMENT DAMAGE.** The 'towed dead' vehicle must be towed in as near a straight line as possible (minimum).
- (22) **EQUIPMENT DAMAGE.** When the engine of the 'towed' vehicle starts, stop both vehicles immediately and disconnect the tow equipment.
- (23) **EQUIPMENT DAMAGE.** If using chains or ropes to tow start a vehicle, and drivers have to baton down, the 'towed/dead' vehicle and the towing vehicle must have inter-vehicle communications.
- (24) **EQUIPMENT DAMAGE.** Serious damage can be caused to the gearbox if downshifts are made manually when the vehicle is travelling at speeds exceeding those given in table 2 below.
- (25) **EQUIPMENT DAMAGE.** Excessive use of lubricating oil in desert conditions will cause an accumulation of sand on lubricated surfaces. Use the minimum amount of oil to achieve the necessary lubrication and protection.

**CHAPTER 1-0**  
**GENERAL - LIST OF CHAPTERS**  
**CONTENTS**

Para

- 1 List of chapters (this chapter)

**LIST OF CHAPTERS**

- 1 This chapter is further sub-divided as follows:

Chap

- 1-1 Introduction and outline data
- 1-2 Evacuation of casualties
- 1-3 Stowage and tools

.. ~~UK RESTRICTED~~

.. ~~RESTRICTED~~

**CHAPTER 1-1**  
**INTRODUCTION AND OUTLINE DATA**  
**CONTENTS**

**Para**

- 1 Introduction
- 7 Engine
- Suspension and tracks
- 8 Suspension
- 9 Tracks
- Transmission
- 10 Gearbox
- 11 Steering
- Electrical equipment
- 12 System
- 13 Batteries
- 14 Fuel system
- 15 Data

**Table**

**Page**

- 1 Physical data ..... 6

**Fig**

- 1 Three quarter front view of Mk 2 vehicle ..... 2
- 2 Three quarter rear view of Mk 2 vehicle ..... 2
- 3 Three quarter front view of Mk 2/1 vehicle ..... 3
- 4 Overall dimensions ..... 4

**INTRODUCTION**

- 1 The Carrier, Personnel, Full Tracked, FV432, Mk 2 (Fig 1 and 2) and Mk 2/1 (Fig 3), vehicles have built-in facilities, on both marks of vehicle, which allow them to be converted to other roles.
- 2 On each vehicle, the rear part of the hull forms the personnel compartment or the compartment adapted to the role of that vehicle.
- 3 Each vehicle is powered by a K60 multi-fuel engine, which drives the tracks through a six-speed automatic gearbox and a controlled differential type steering unit.
- 4 Braking is achieved by using the steering unit brakes.
- 5 The vehicle is wired on a 24 V system, each having three sets of batteries which are charged by the rectified output of two alternators.
- 6 The ventilation filter housing is mounted on the right sideplate, externally for the Mk 2 vehicles and internally for the Mk 2/1 vehicles.

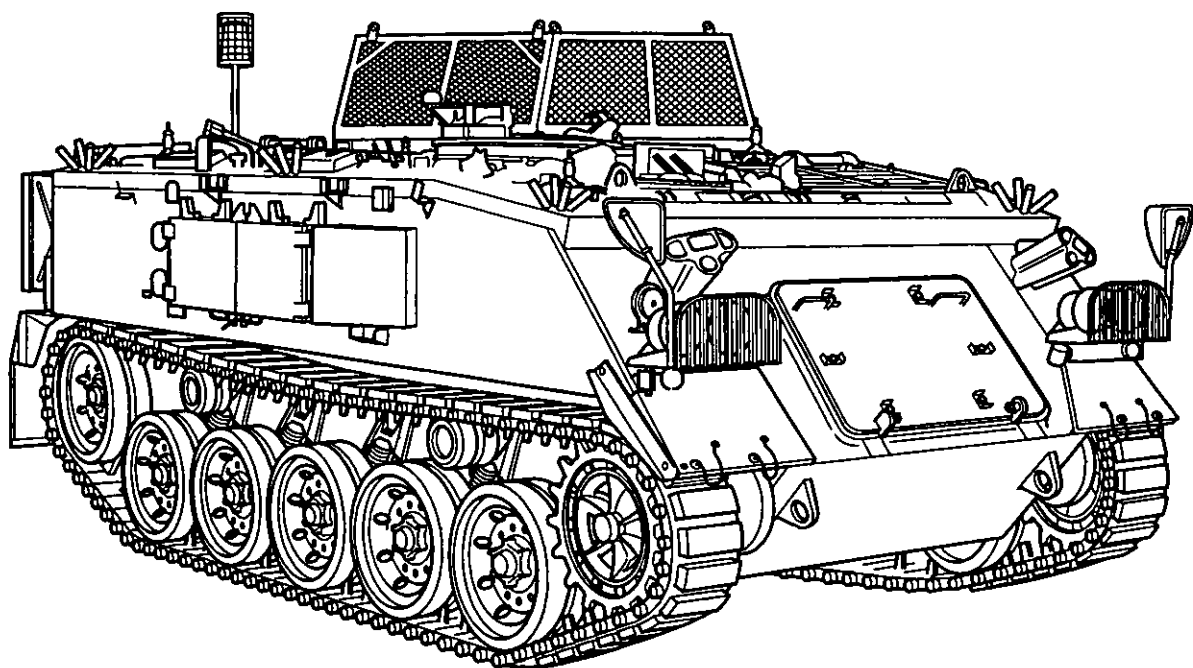

430/20091

Fig 1 Three quarter front view of Mk 2 vehicle

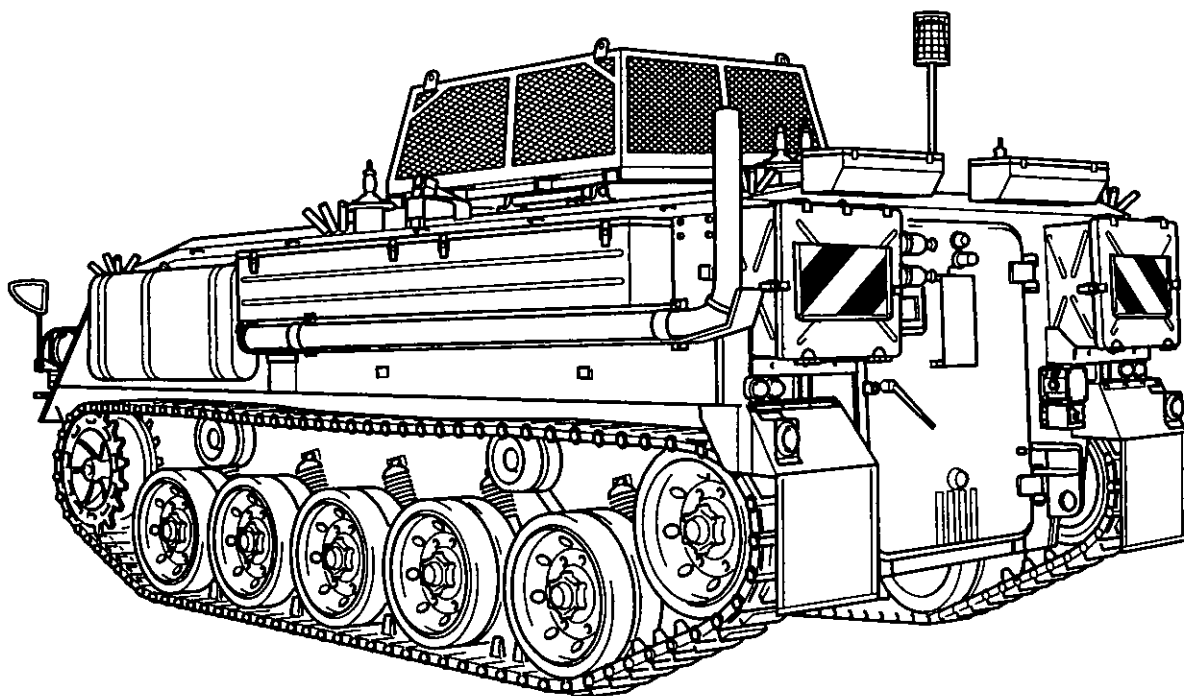

430/20092A

Fig 2 Three quarter rear view of Mk 2 vehicle

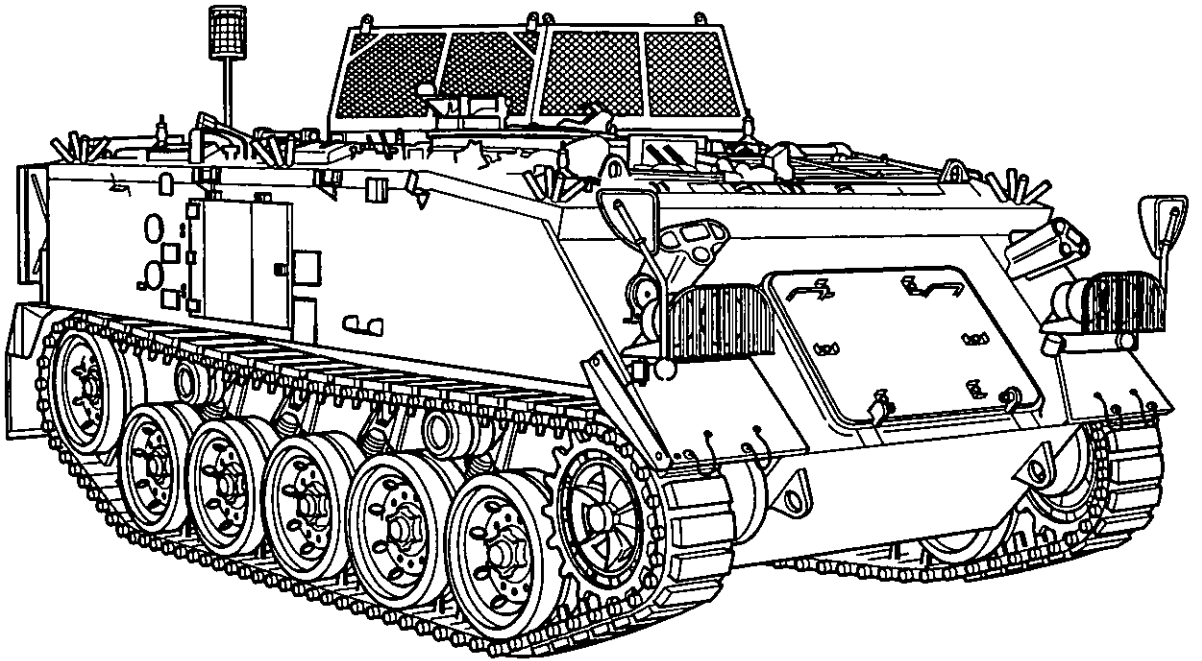

432/20093

Fig 3 Three quarter front view of Mk 2/1 vehicle

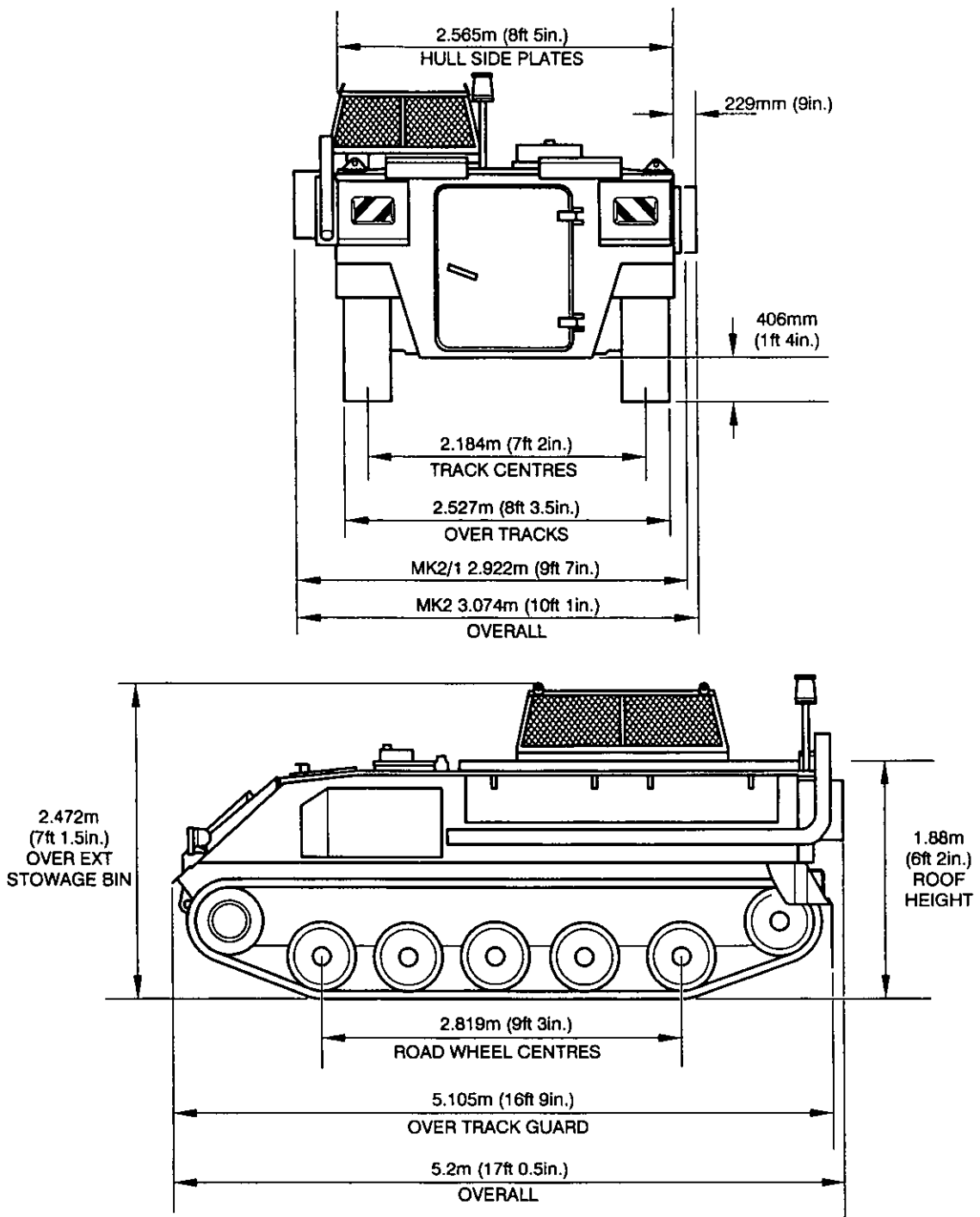

430/20192

Fig 4 Overall dimensions

## ENGINE

7 The engine is a K60 Mk 4F or Mk 6F, two stroke, multi-fuel, and compression ignition. Opposed piston type. The maximum governed speed is 3,750 rev/min while the idling speed is 800 rev/min.

## SUSPENSION AND TRACKS

### Suspension

8 The vehicle is supported by five torsion bar units on each side with axle arms in the trailing position. The shock absorbers are of the friction type and are only fitted to the front and rear stations. The wheels are rubber tyred with two on each suspension unit and track adjuster.

### Tracks

9 Each track consists of 90 links when new, and these are rubber bushed with rubber-padded links and are connected by hexagonal pins. The condemnation limit of the tracks is 86 links with the hydraulic ram fully extended.

## TRANSMISSION

### Gearbox

10 The vehicle is driven by a GM-Allison TX200-4A semi-automatic gearbox having six forward gears and one reverse, with a torque converter operating in 1st, 3rd, and reverse.

### Steering

11 Steering is aided by the use of a controlled differential unit.

## ELECTRICAL EQUIPMENT

### System

12 A 24 V negative earth system is used within the vehicle, with an ac generating system that is rectified for battery charging and general purpose. Refer to Chapter 2-6 of this publication for ratings and locations of fuses and circuit breakers.

### Batteries

13 There are six batteries fitted within the vehicle, two connected in series for automotive purposes, two fitted in series for the ventilation system, and a two connected in series for radio equipment.

## FUEL SYSTEM



14 The fuel system consists of two main tanks, which are mounted in the rear of the vehicle one on either side above the track guard and a collector tank, which is located on the hull bottom plate under the rear floor. The two main tanks feed via a stop cock into the collector tank where the fuel is drawn up by an electric pump which delivers the fuel through a filter to the fuel injector. Each tank is vented through a pipe, which is connected to a vent valve mounted on the roof plate.

## DATA

15 Table 1 lists the physical data relevant to the Carrier, Personnel, Full Tracked FV432 Mk 2 and Mk 2/1.



TABLE 1 PHYSICAL DATA

Serial (1)	Heading (2)	Detail (3)
1	Crew	Two, driver and commander.
2	Personnel	Dependent on derivative
3	Dimensions	Refer to Fig 4
4	Weights Unladen (fully fuelled and with driver) Laden	13,895 kg (13.673 tons) 15,392 kg (15.145 tons)
5	Bridge classification	15
6	Fuel	Multifuel – diesel, gas turbine, MT gasoline, premium grade motor spirit or a mixture of these fuels.
7	Engine	K60 Mk 4F or Mk 6F, two stroke, multi-fuel, compression ignition. Opposed piston type.
8	Gearbox	GM-Allison TX200-4A semi-automatic gearbox having six forward gears and one reverse, with a torque converter operating in 1st, 3rd, and reverse.
9	Governed Engine speed Maximum Idle	3,750 rev/min 800 Rev/min
10	Gears and speed Gear 1 2 3 4 5 6 Reverse	Speed 9.8 km/h (6.1 mile/h) 13.7 km/h (8.5 mile/h) 19.5 km/h (12.1 mile/h) 27 km/h (16.8 mile/h) 37.6 km/h (23.4 mile/h) 52.2 km/h (32.5 mile/h) 8.65 km/h (5.4 mile/h)
11	Performance  (permitted)	
12	Fuel consumption 	
13		

(continued)

**TABLE 1 PHYSICAL DATA (continued)**

Serial (1)	Heading (2)	Detail (3)
14	Range of operation  ██ ██	
15	Maximum gradient	35 degrees
16	Maximum vertical obstacle	609 mm (2 ft)
17	Minimum turning circle	5.334 m (17 ft 6 in.)
18	Suspension Type Wheels Shock absorber	Torsion bar, five units on each side with axle arms in the trailing position. Track adjuster at rear. 609 mm (24 in.) diameter, rubber tyred. Two on each suspension unit and track adjuster. Friction type, fitted to the front and rear stations only.
19	Tracks Links per track (new) Condemnation limit	90 86 (with hydraulic ram fully extended)
20	Track guide rollers	Two for each track
21	Steering	Lever operated controlled differential unit.
22	Armament	Pintle mounting on cupola for commander's machine gun in ground role.
23	Smoke protection	Two forward facing multi-barrelled smoke dischargers.
24	Ammunition Machine gun Smoke discharger	Eight boxes of 200 rounds, belted for GPMG Six rounds (loaded in dischargers)
25	Vision Driver Commander	Head out for opened up position. Single wide angled AFV No. 33 Mk1 periscope 360 deg rotation cupola, with three periscopes, both outer periscopes fixed. Centre AFV No. 32 Mk 1 periscope can be pivoted axially in vertical plane.
26	Electrical equipment Batteries Alternators Lamps Fuses Circuit breakers	Six, No. 4 Mk 3, 12V, maintenance free batteries, rated at 110amp/hour Two No. 1 Mk 1 alternators. Max. output 100amp/hours, regulated to 28.5V at 1,750 rev/min (alternator speed) Refer to Chap 2-6. Refer to Chap 2-6. Refer to Chap 2-6.

(continued)

TABLE 1 PHYSICAL DATA (continued)

Serial (1)	Heading (2)	Detail (3)	
27	Capacities	Litres	(Imperial)
	Fuel tanks	454	(100 gal)
	Engine lubrication system	33	(58 pints)
	Gearbox (modified)	16.5	(29 pints)
	Engine governor	1.15	(2 pints)
	Coolant system	44.3	(78 pints)
	Hydraulic fan drive	22.4	(39 pints)
	Steering unit	26.7	(47 pints)
	Final drives (each)	4.3	(7.5 pints)
	Road and track adjuster wheels (each)	1.7	(3 pints)

**CHAPTER 1-2**  
**EVACUATION OF CASUALTIES**  
**CONTENTS**

Para

- Introduction
- 1 General (WARNINGS)
- 4 Medical aspects of rescue
- 8 Rescue Priority
- 10 Action in an emergency
- Rescue drills
- 19 General
- 20 Access hatches (WARNING)
- 21 Access rear door

Chart

Page

- 1 Rescue Priorities..... 3

Fig

Page

- 1 Interior of vehicle from driver's compartment ..... 5
- 2 Rear of vehicle..... 6
- 3 Cupola and driver's hatch ..... 6
- 4 Interior of vehicle from rear (Mk 2 vehicle) ..... 7/8

**INTRODUCTION**

**General**

**WARNINGS**

(1) **PERSONNEL INJURY. DUE TO THE DIFFERING VARIANTS OF THE FV430 SERIES THE EVACUATION DRILLS WILL CHANGE FROM VARIANT TO VARIANT. BEFORE USE, ADVICE FOR EVACUATION DRILLS SHOULD BE SOUGHT FROM THE U.E.M. (UNIT EQUIPMENT MANAGER)**

(2) **PERSONNEL INJURY. WHERE ROOF MOUNTED EQUIPMENT PREVENTS THE R/H MORTAR HATCH BEING OPENED, A RESTRICTION OF FOUR (4) PERSONNEL MAXIMUM CAN BE TRANSPORTED IN THE REAR OF THE VEHICLE.**

(3) **PERSONNEL INJURY. BOWMAN ANTENNAS MAY TRANSMIT AT ANY TIME. SHOULD A CREW MEMBER GRAB AN ANTENNA WHILST TRANSMITTING THEY MAY SUFFER RF BURNS. UNDER NO CIRCUMSTANCES MUST AN ANTENNA BE TOUCHED WHEN FITTED TO THE VEHICLE UNLESS EQUIPMENT IS TURNED TO STANDBY.**

(4) **PERSONNEL INJURY. WHEN CARRYING OUT ANY TYPE WORK ON THE FV432 (BOWMAN) VEHICLE ATTENTION MUST BE MADE TO THE VARIOUS SAFETY NOTICES WHICH ARE POSITIONED THROUGHOUT THE VEHICLE.**

(5) **PERSONAL INJURY. ALL USERS AND MAINTAINERS MUST PAY ATTENTION TO THE BOWMAN SAFETY NOTICES AS ISSUED BY BOWMAN LAND DIGITIZATION (BLD) TO UNITS.**

- 1 The drills described in this chapter assume that the following conditions exist at the time of rescue:
  - 1.1 One member only of the AFV's crew is incapacitated.
  - 1.2 The rescue is carried out by the other members of the crew without outside assistance.

- 1.3 The AFV is not partly or wholly overturned.
- 1.4 The AFV is closed down at the start of the drill, with the hatches locked.
- 1.5 Crewmen are wearing NBC protective clothing and crewman's helmets but no webbing equipment.

2 More serious incidents concerned with more than one incapacitated crewman per AFV will need outside assistance. However, the same rescue drills will still apply.

3 In the worst type of incident very prompt action to fight fire and/or recover an AFV will be needed before the rescue drills described can begin.

### **Medical aspects of rescue**

4 The ability to perform prompt and effective first aid particularly that aimed at the maintenance of breathing and control of bleeding is an essential requirement for all soldiers.

5 First aid, by definition, is the application of simple precautions pending the arrival of professional help. Remember that professional help may not be readily at hand. The man on the spot must therefore always act decisively, accepting any risks in making his decision.

6 The casualties' helmet must remain on throughout rescue operations and if possible the crew must support the casualties' head at all times.

7 The Action in an EMERGENCY listed in the following paragraphs show the main points to look for and the priority of action.

### **Rescue priority**

8 Whilst, as a general rule, first aid is most efficiently applied outside an AFV there are important exceptions. There are also rare occasions when first aid hardly matters at all initially. The following chart shows the decisions to be made at the start of the rescue, by the senior active crewman.

9 Check for consciousness:

- 9.1 A - Open the Airway.
- 9.2 B - Check for Breathing.
- 9.3 C - Check for Circulation (pulse).
- 9.4 D - Check for Disabilities i.e. unconscious, breaks, burns etc.

**CHART 1 –RESCUE PRIORITIES**

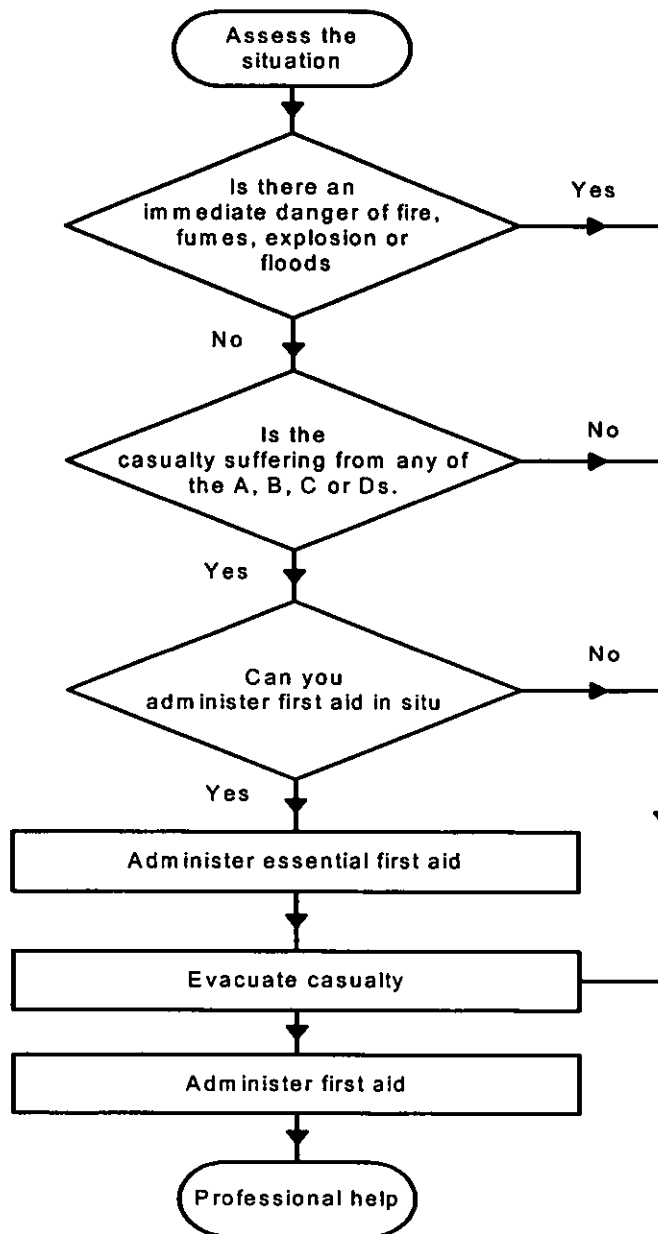

**Action in an emergency**

10 Are you or the casualty in danger?

11 Remove the danger. Move the casualty only if absolutely necessary.

12 Under active service conditions, or where there is immediate danger of fire, fumes or flood, priority must be given to restoring breathing and stemming bleeding, followed by the immediate evacuation of the casualty from the vehicle to a place of safety where medical attention can be provided. An injured man in a sitting position may quickly die under certain circumstances, and as a general rule he should be in the recovery position as soon as possible. While the casualty is in a sitting or upright position his head must, at all times, be supported and held up to ensure that he can breath freely.

13 Where there is no immediate danger from enemy action, fire, flood and fumes, priority must be given to administering first aid and calling for skilled medical personnel. Breathing should be restored, bleeding arrested and the casualty treated for shock. Only if the casualty is in physical danger, as from a burning vehicle, should he be evacuated before medical attention arrives.

14 More serious incidents concerned with more than one incapacitated crewman per vehicle will need outside assistance. However, the same rescue drills will still apply.

15 In the worst type of incidents very prompt action to fight fire and/or recover a vehicle will be needed before the rescue drills described can begin.

16 Particular attention is drawn to the Medical aspects of rescue.

17 The following paragraphs contain all the drills necessary for the rescue of any incapacitated member of the crew.

18 Each drill must be carried out in conjunction with para 4 to 7 "Medical Aspects of Rescue".

## RESCUE DRILLS

### General

19 The drills in this chapter assume that the following conditions exist at the time of rescue:

19.1 One member of the crew is incapacitated.

19.2 The rescue is carried out by the other members of the crew, without outside assistance.

19.3 The vehicle is not partly or wholly overturned.

19.4 The vehicle is closed down at the start of the drill, with the hatches locked from the inside.

19.5 Crewmen are wearing NBC protective clothing and crewman's helmets but no webbing equipment.

### Access hatches

20 When access is required through the hatches they are opened as follows:

20.1 The driver's hatch is accessed from the top of the vehicle or through the commanders or personnel compartment. The hatch is opened using a rotatable catch (Fig 3 (2)). A spring-loaded catch retains the hatch in the open position.

20.2 The commander's cupola is accessed through the personnel compartment and the hinged hatch in the top of the cupola, and is opened by rotating two catches (Fig 3(1)). A stop bracket and spring catch retains the hatch in the open position.

### WARNING

**PERSONNEL INJURY. WHERE ROOF MOUNTED EQUIPMENT PREVENTS THE R/H MORTAR HATCH BEING OPENED, A RESTRICTION OF FOUR (4) PERSONNEL MAXIMUM CAN BE TRANSPORTED IN THE REAR OF THE VEHICLE.**

20.3 The mortar hatch is the large circular hatch over the personnel compartment. When open, the four segments fold back clear of the hatchway (Assuming that there has been no roof mounted baskets or equipment fitted to the vehicle). The weight of the segments is counterbalanced by torsion bars. The door is opened by rotating six catches (Fig 4(1))

**Access rear door**

**WARNING**

**SAFETY HAZARD. IF VEHICLE IS ON AN UPWARD SLOPE, RELEASING THE REAR DOOR CATCH WILL ALLOW THE REAR DOOR TO SWING OPEN UNCONTROLLABLY WITH POSSIBLE SERIOUS RESULTS.**

21 The rear door is hinged and can be secured in the closed position by a locking catch operated by a handle (Fig 1 (4)) inside and Fig 2 (1)) outside the vehicle. The rear door can be held in the open position by using the strut (Fig 1 (2)).

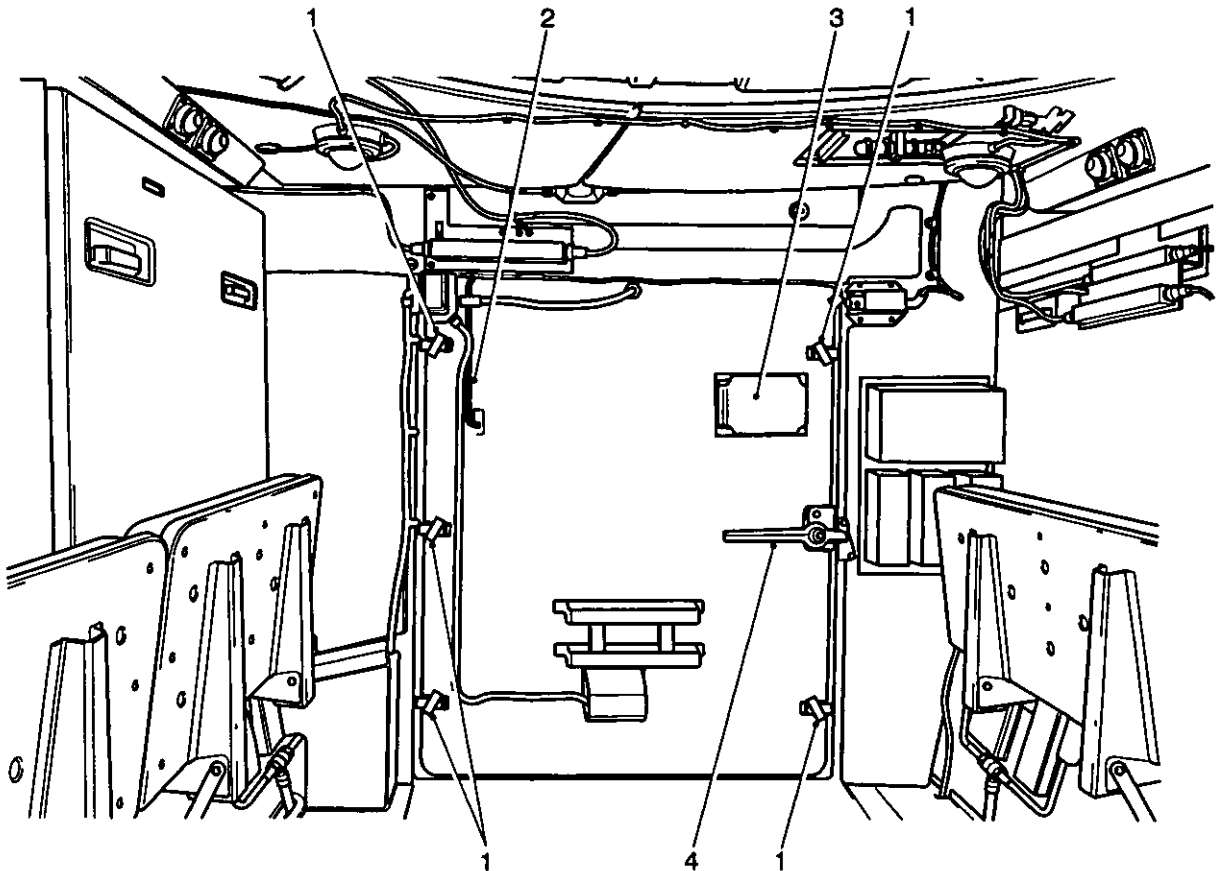

432/20096

- |   |                            |   |                    |
|---|----------------------------|---|--------------------|
| 1 | Rear door clamping catches | 3 | Observation window |
| 2 | Rear door strut            | 4 | Door handle        |

Fig 1 Interior of vehicle from driver's compartment



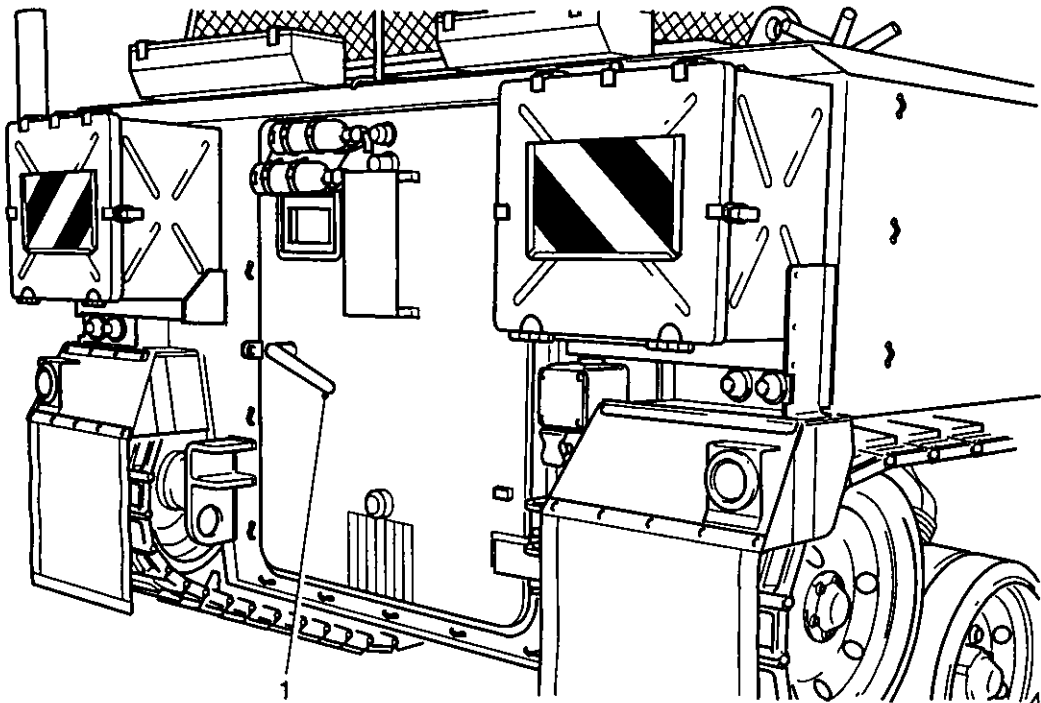

430/20014

1 Rear door handle

Fig 2 Rear of vehicle

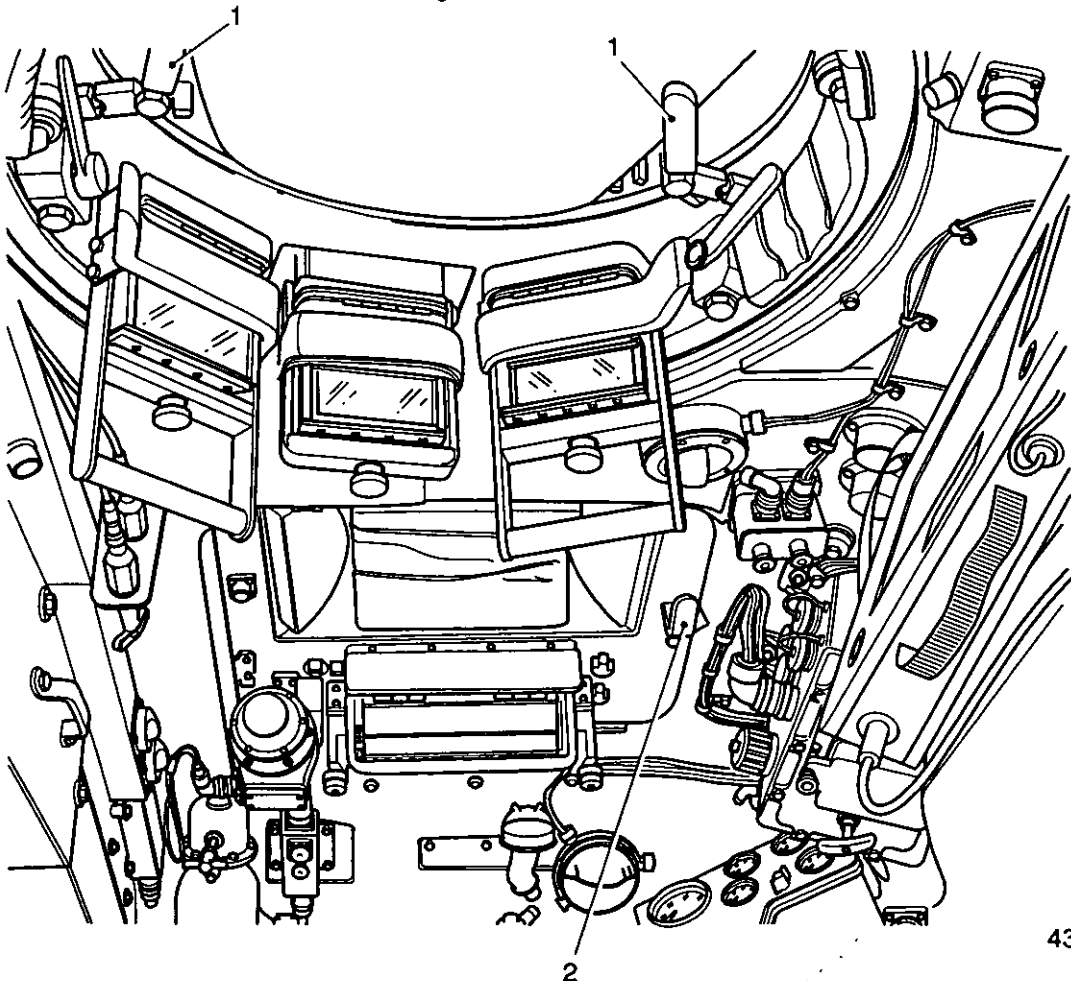

432/20099

1 Cupola door catches

2 Locking catch

Fig 3 Cupola and driver's hatch

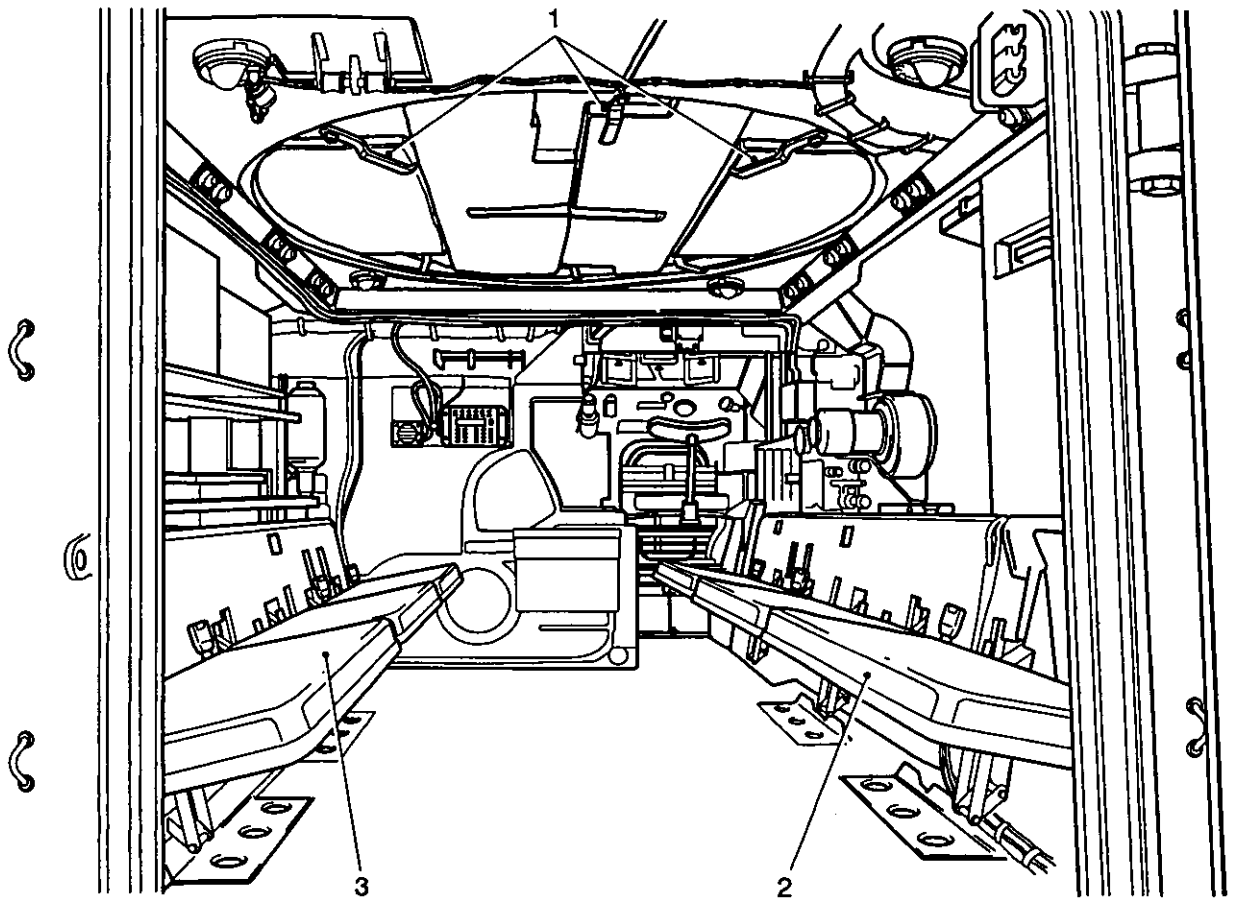

430/20100

- 1 Mortar hatch rotatable catches
- 2 Right, personnel seats

- 3 Left, personnel seats

Fig 4 Interior of vehicle from rear (Mk 2 vehicles)

~~UNRESTRICTED~~

~~UNRESTRICTED~~

**CHAPTER 1-3**  
**STORAGE AND TOOLS**  
**CONTENTS**

Para

- 1 Introduction
- 2 External stowage  
Internal stowage
- 3 Drivers and commander's SA80 stowage
- 4 Tools

Fig

Page

1	External stowage areas.....	1
2	Drivers and Commanders SA 80 stowage .....	2

**INTRODUCTION**

1 This chapter details the location of stowage on the armoured personnel carrier, which are not classed as fittings.

**EXTERNAL STOWAGE**

2 Fig 1 details the location of the external stowage bins.

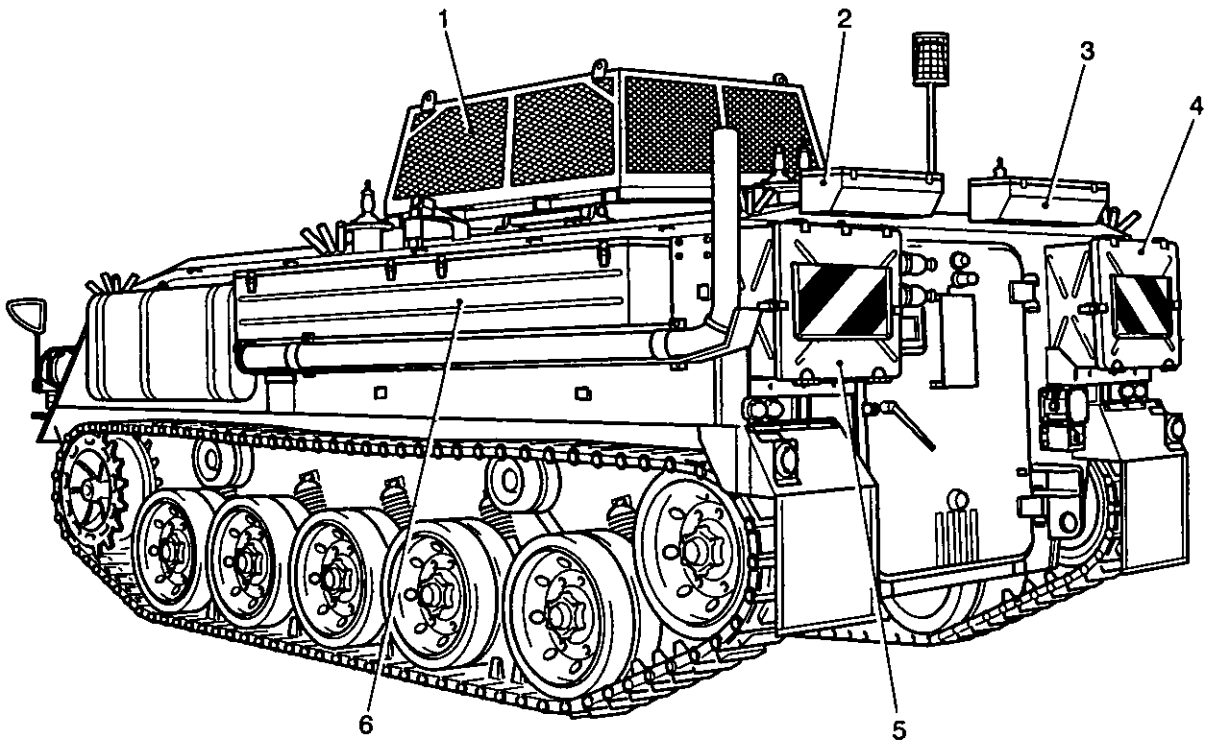

430/20101A

- |   |                  |   |                   |
|---|------------------|---|-------------------|
| 1 | Bin roof LH      | 4 | Bin rear plate RH |
| 2 | Bin rear roof LH | 5 | Bin rear plate LH |
| 3 | Bin rear roof RH | 6 | Bin pannier LH    |

Fig 1 External stowage areas

**INTERNAL STORAGE****Driver's and commander's SA80 stowage**

- 3 Fig 2 details the location of the stowage brackets for the driver and commanders SA80 stowage.

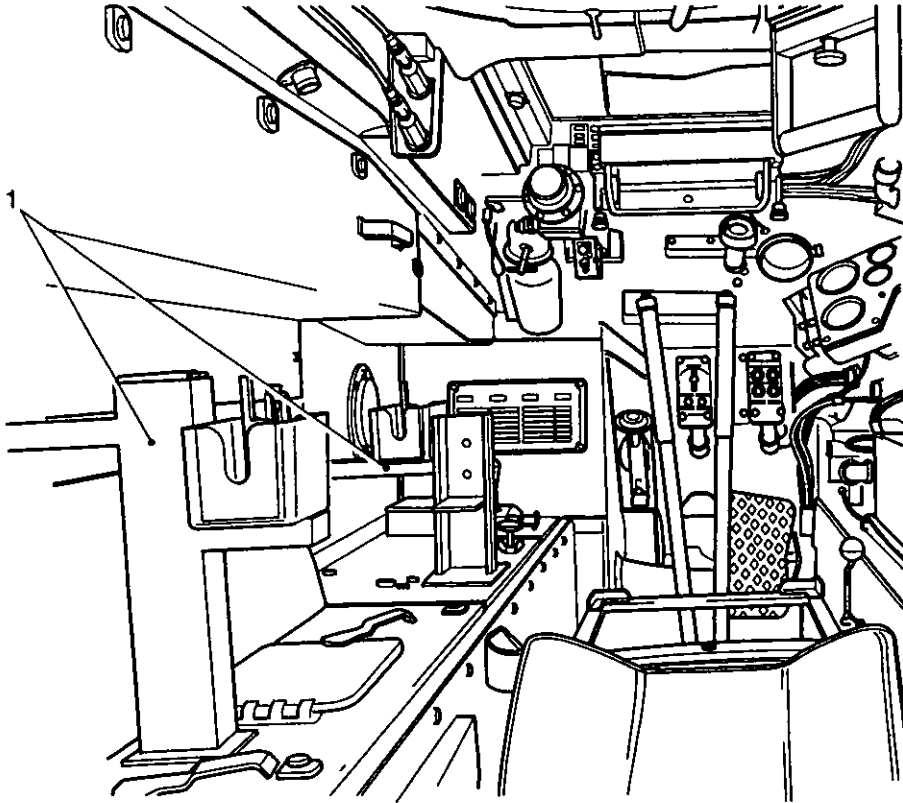

432/468

- 1 Weapon stowage brackets

Fig 2 Driver and Commanders SA80 stowage

**TOOLS**

- 4 The vehicle tools associated with this vehicle are detailed in AESP 2350-T-250-741.

**CHAPTER 2-0**  
**VEHICLE SYSTEMS – LIST OF CHAPTERS**  
**CONTENTS**

Para

- 1 List of chapters (this chapter)

**LIST OF CHAPTERS**

- 1 This chapter is further sub-divided as follows:

Chap

- 2-1 Fire fighting systems
- 2-2 Hull and fittings
- 2-3 Power pack
- 2-4 Final drive, suspension and tracks
- 2-5 Ventilation control system
- 2-6 Electrical system
- 2-7 Vehicle operation
- 2-8 Failure diagnosis

~~UNRESTRICTED~~

~~UNRESTRICTED~~

**CHAPTER 2-1**  
**FIRE FIGHTING SYSTEMS**  
**CONTENTS**

Para

- 1 Fire fighting equipment
- 6 Operation of a portable extinguisher BCF (WARNINGS) (CAUTION)
- 10 Operation of a portable extinguisher, 2 kg dry powder (WARNINGS)
- 11 Operation of the fixed fire extinguisher (WARNINGS)
- 13 Fire alarm system
- 17 Testing the circuit
- 22 Action in the event of fire (WARNINGS)
- 24 External fires, driver's and personnel compartment fires
- 25 Power pack compartment fires (WARNINGS)
- Maintenance
- 27 Checking a portable fire extinguisher
- 31 Servicing the fixed fire extinguisher system

Fig

Page

1	Driver's compartment.....	2
2	Rear of vehicle.....	3
3	Interior of vehicle from rear (Mk 2 vehicles) .....	3
4	Front of vehicle .....	4
5	BCF type portable fire extinguisher .....	5
6	2 kg dry powder fire extinguisher.....	6
7	Fixed fire extinguisher cylinders .....	7
8	Location of fixed fire extinguisher control cover flap RH side (Mk 2/1 Vehicles).....	7
9	Location of fixed fire extinguisher control cover flap LH side .....	8
10	Driver's controls and instruments .....	9
11	Distribution panel No. 6, Mk 1 .....	12

**FIRE FIGHTING EQUIPMENT**

- 1 Two internally fitted BCF and three external mounted dry powder portable fire extinguishers and a fixed Hectoflouropropane (FM 200) system are provided to combat vehicle fires.
- 2 The portable fire extinguishers are suitable for combating all types of fire and operating instructions are marked on each extinguisher.
- 3 The extinguishers are located as follows:
  - 3.1 BCF Type
    - 3.1.1 One (Fig 1(3)) in the driver's compartment mounted on the power pack compartment plate.
    - 3.1.2 One (Fig 3(3)) in the personnel compartment mounted on the power pack partition rear plate.
  - 3.2 Dry Powder
    - 3.2.1 Two (Fig 2(1)) are carried on the outside of the vehicle, on the rear door.
    - 3.2.2 One (Fig 4(1)) on the sloping plate at the front of the vehicle.
- 4 Operating instructions are clearly marked on each extinguisher (see Figs 5 and 6).



5 Two fixed FM 200 cylinders (Fig 7(4)) are provided to combat fires in the power pack compartment. They are mounted on a bracket on the rear plate of the power pack compartment.

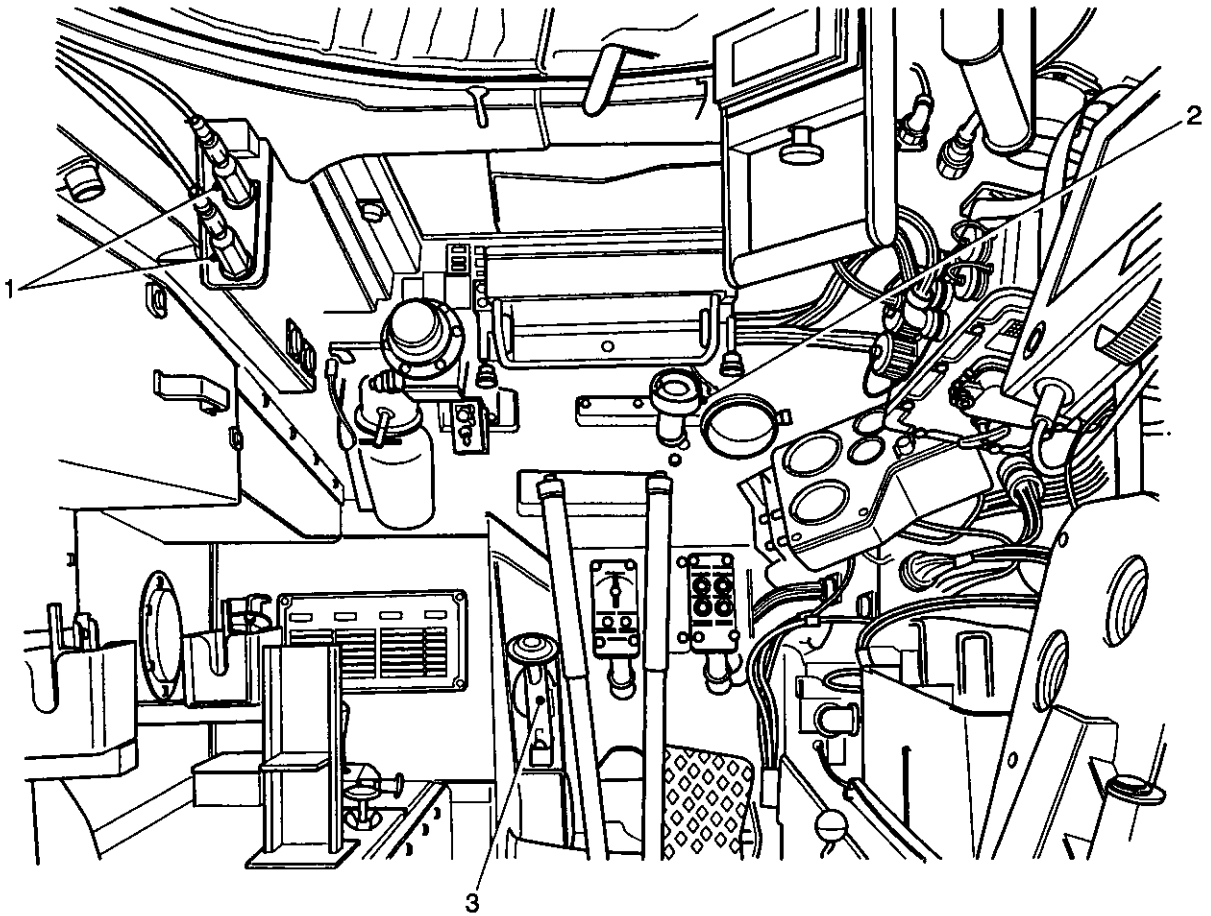

432/20102

- |   |   |   |                           |
|---|---|---|---------------------------|
| 1 | Fixed fire extinguisher remote controls | 3 | Fire extinguisher bracket |
| 2 | Fire warning light                      |   |                           |

Fig 1 Driver's compartment

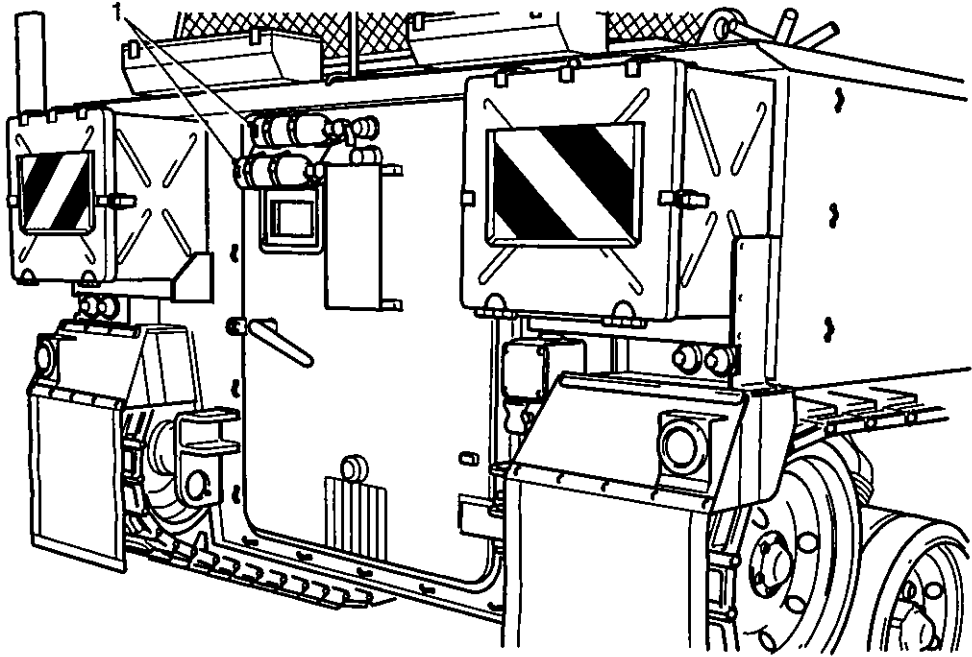

430/20016

1 Portable fire extinguishers

Fig 2 Rear of vehicle

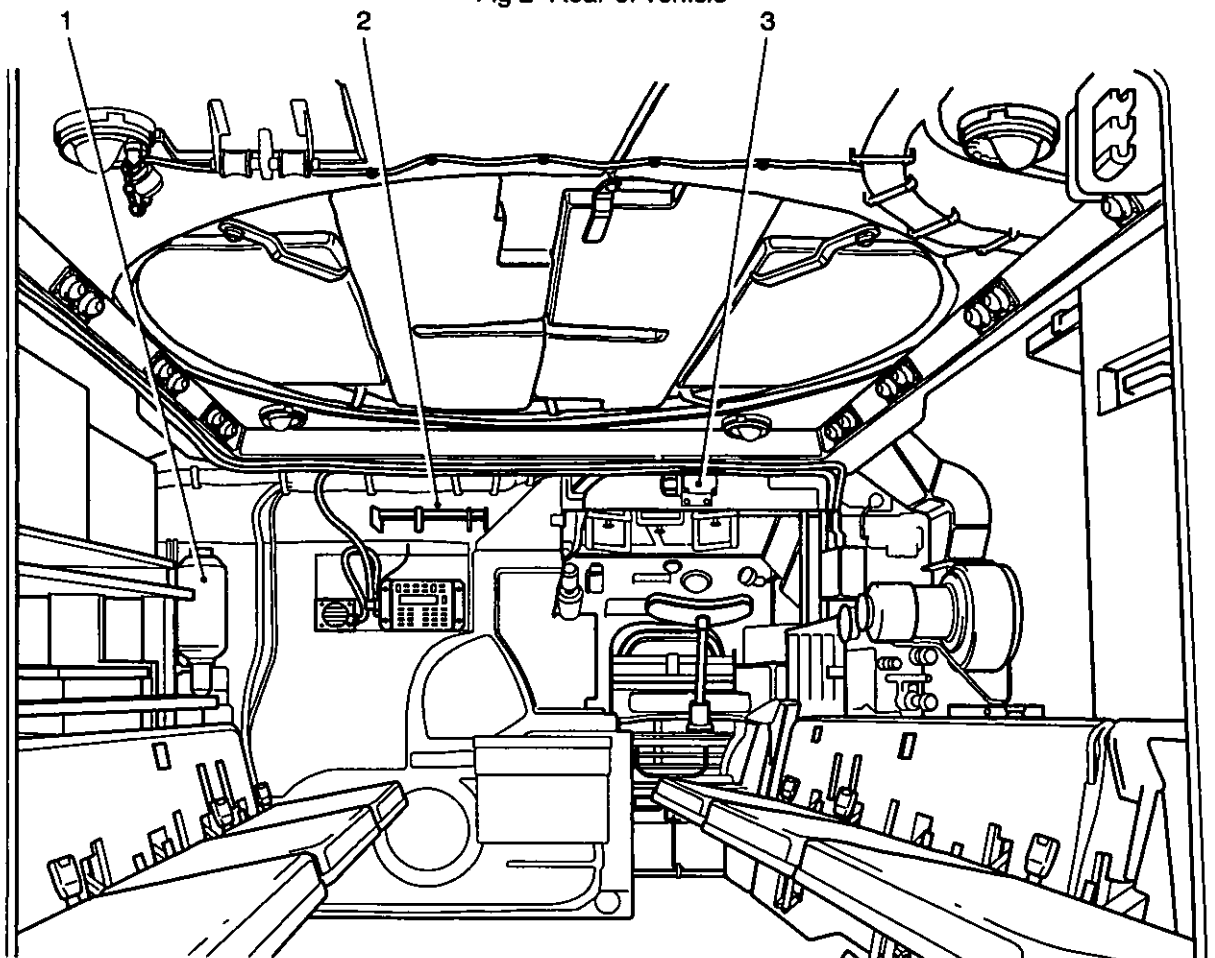

432/20110

1 Fixed fire extinguisher cylinders  
2 Portable fire extinguisher bracket

3 Fire warning light and flasher unit

Fig 3 Interior of vehicle from rear (Mk 2 vehicles)

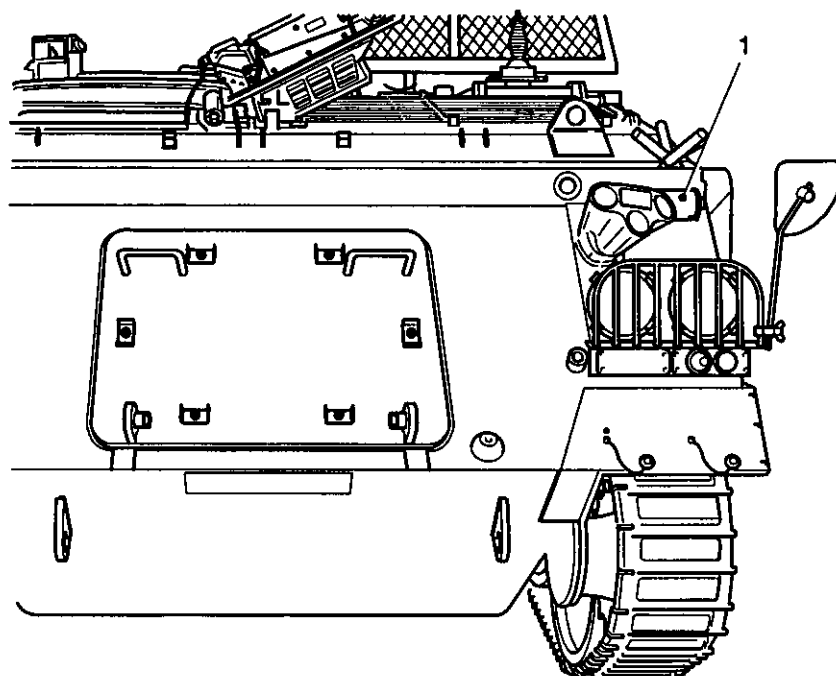

432/20106

1 Portable fire extinguisher

Fig 4 Front of vehicle

**Operation of a portable extinguisher BCF****WARNINGS**

(1) **PERSONNEL SAFETY.** IN THE EVENT OF A FIRE ENSURE ALL PERSONNEL HAVE BEEN EVACUATED FROM THE VEHICLE AND THAT ALL NON-ESSENTIAL PERSONNEL HAVE BEEN EVACUATED TO A SAFE AREA.

(2) **ASPHYXIATION HAZARD.** THIS EQUIPMENT CONTAINS A BCF FIRE SUPPRESSED SYSTEM. IF BCF VAPOUR IS BREATHED, IT CAN CAUSE SUFFOCATION. ONLY TRAINED PERSONNEL UNDER SUPERVISION ARE ALLOWED TO WORK ON THE SYSTEM. ANYONE WHO HAS BREATHED BCF VAPOUR IS TO RECEIVE MEDICAL ATTENTION.

(3) **ASPHYXIATION HAZARD.** THE VAPOURS OF ALL FIRE EXTINGUISHERS DISPLACE AIR AND CAN CAUSE ASPHYXIA IN CONFINED SPACES. OPEN ALL HATCHES AND ALLOW TIME FOR FUMES TO DISPERSE BEFORE PERSONNEL RE-ENTER THE VEHICLE.

**CAUTION**

**SMOKE SOURCE.** Before operating a fire extinguisher, consideration should be given to the possible cause of smoke. Allowance should be made for smoke from surplus oil, new engine paintwork, new insulation on the exhaust system and any other normal vapour.

6 Unclip and remove the extinguisher from its bracket; take up a suitable position as close to the fire as is safely, possible.

7 With the discharge head downward, bang the striker knob (see Fig 5(2)) on a hard surface.

8 Direct the spray cone at the seat of the nearest flames first, sweeping from side to side, progressing the spray over the fire area but leaving no flame behind it.

9 During operation, the extinguisher must be held downward with a tilt of not more than 45 deg. The rate of discharge cannot be controlled; once the discharge starts, the extinguishers will empty completely. When discharged, the container should be discarded and a replacement obtained as soon as possible.

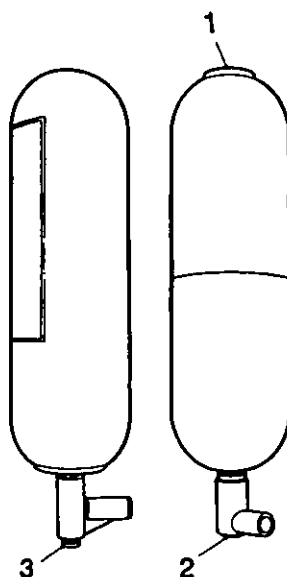

432/026

- |   |                              |   |                                 |
|---|------------------------------|---|---------------------------------|
| 1 | Test indicator               | 3 | Striker knob and test indicator |
| 2 | Discharge nozzle and striker |   |                                 |

Fig 5 BCF type portable fire extinguisher

#### Operation of portable extinguisher, 2 kg dry powder

#### WARNINGS

**(1) PERSONNEL SAFETY. IN THE EVENT OF A FIRE, ENSURE ALL PERSONNEL HAVE BEEN EVACUATED FROM THE VEHICLE AND THAT ALL NON-ESSENTIAL PERSONNEL HAVE BEEN EVACUATED TO A SAFE AREA.**

**(2) ASPHYXIATION HAZARD. DRY POWDER EXTINGUISHERS ARE NON-TOXIC. HOWEVER, THIS TYPE OF EXTINGUISHER IS NOT TO BE USED IN A CONFINED SPACE UNLESS IN AN EXTREME EMERGENCY.**

**(3) ASPHYXIATION HAZARD. THE VAPOURS OF ALL FIRE EXTINGUISHERS DISPLACE AIR AND CAN CAUSE ASPHYXIA IN CONFINED SPACES. OPEN ALL HATCHES AND ALLOW TIME FOR FUMES TO DISPERSE BEFORE PERSONNEL RE-ENTER THE VEHICLE.**

- 10 To use the 2 kg dry powder portable fire extinguisher, proceed as follows:
  - 10.1 Hold the extinguisher (see Fig 6) upright.
  - 10.2 Remove the cap from the discharge nozzle (7), and remove the ring pull pin (1) from the handle assembly.
  - 10.3 From a position as near the fire as possible, direct the nozzle at the base of the nearest flames and squeeze the operating handle (2) to commence the discharge.
  - 10.4 Release the operating handle to halt the discharge.
  - 10.5 After use, check the gauge indication and replace the extinguisher if necessary.

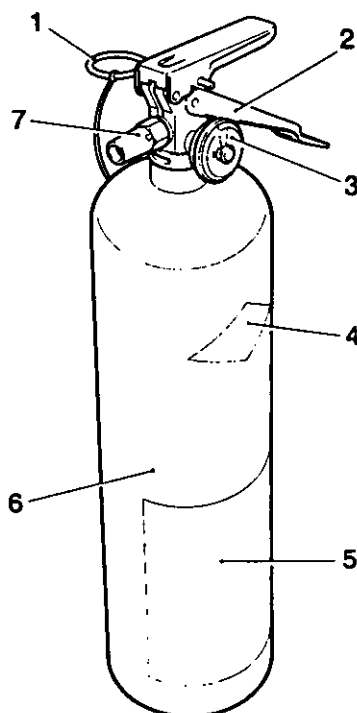

432/103

1	Ring pull pin	5	Operating instructions
2	Operating handle	6	Cylinder
3	Indicator gauge	7	Discharge nozzle
4	Inspection record card		

Fig 6 2 kg dry powder fire extinguisher

**Operation of the fixed fire extinguisher****WARNINGS**

(1) **PERSONNEL SAFETY. IN THE EVENT OF A FIRE ENSURE ALL PERSONNEL HAVE BEEN EVACUATED FROM THE VEHICLE AND THAT ALL NON-ESSENTIAL PERSONNEL HAVE BEEN EVACUATED TO A SAFE AREA.**

(2) **ASPHYXIATION HAZARD. THIS EQUIPMENT CONTAINS A HECTOFLUROPROPANE (FM 200) FIRE SUPPRESSED SYSTEM. IF FM 200 VAPOUR IS BREATHED, IT CAN CAUSE SUFFOCATION. ONLY TRAINED PERSONNEL UNDER SUPERVISION ARE ALLOWED TO WORK ON THE SYSTEM. ANYONE WHO HAS BREATHED FM 200 VAPOUR IS TO RECEIVE MEDICAL ATTENTION.**

(3) **ASPHYXIATION HAZARD. THE VAPOURS OF ALL FIRE EXTINGUISHERS DISPLACE AIR AND CAN CAUSE ASPHYXIA IN CONFINED SPACES. OPEN ALL HATCHES AND ALLOW TIME FOR FUMES TO DISPERSE BEFORE PERSONNEL RE-ENTER THE VEHICLE.**

11 Switch off the engine and battery master switches.

12 Extinguisher controls are operated as detailed below:

12.1 Driver's compartment. Turn one of the control handles (Fig 1(1)), located on the roof plate to the left of the hatch, a quarter of a turn counter clockwise and pull sharply.

12.2 Outside the vehicle. Turn one of the handles, located beneath the rubber flaps (Fig 8(1)) and Fig 9(1)) a quarter turn anti-clockwise and pull sharply.

**NOTE**

The rate of discharge from a cylinder cannot be controlled. Once the seal has been broken, the cylinder will discharge completely. If the fire persists after one cylinder has been discharged, operate the control for the other cylinder. A replacement cylinder should be installed as soon as possible.

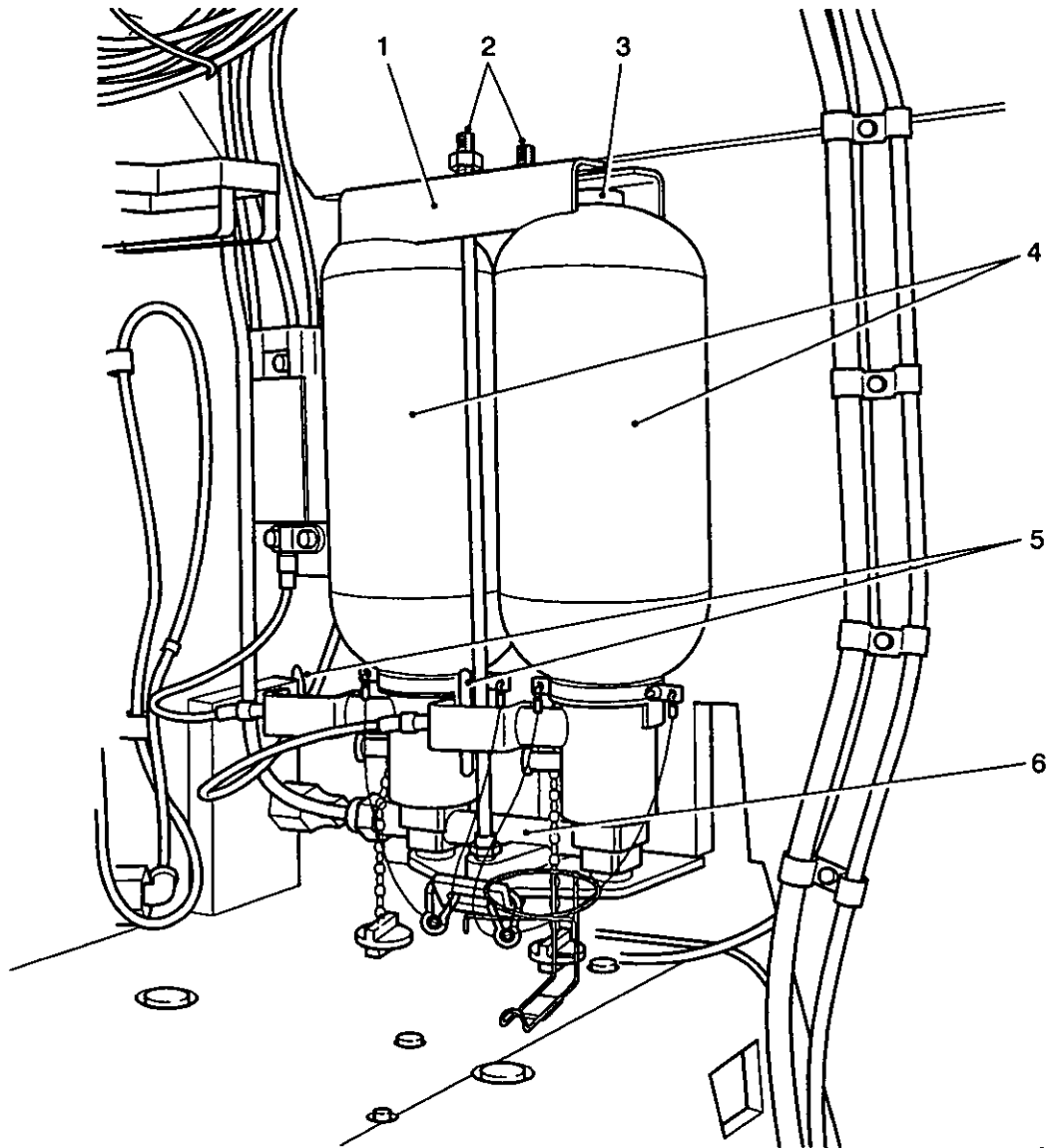

432/20108

- 1 Securing plate
- 2 Through bolt nuts
- 3 Pressure indicator gauge

- 4 Cylinders
- 5 Finger bars
- 6 Manifold

Fig 7 Fixed fire extinguisher cylinders

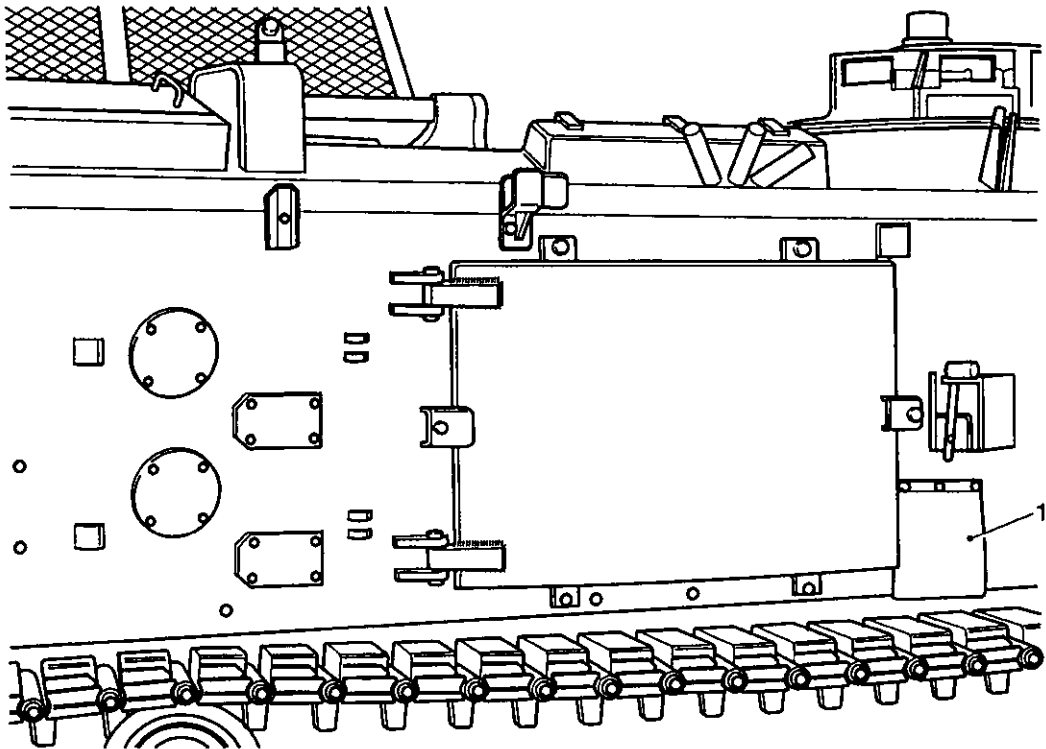

432/029

- 1 Fixed fire extinguisher control cover flap

Fig 8 Location of fixed fire extinguisher control cover flap RH side (Mk 2/1 vehicles)

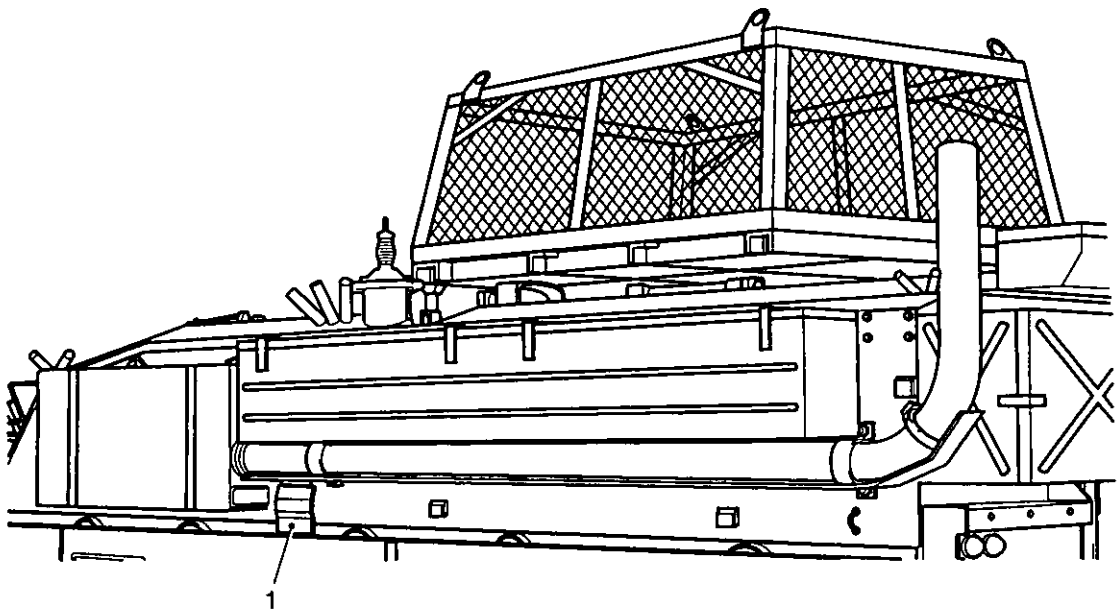

432/20107

- 1 Fixed fire extinguisher control cover flap

Fig 9 Location of fixed fire extinguisher control cover flap LH side

## FIRE ALARM SYSTEM

13 The system is operated electrically and is designed to give visible and audible warnings, if the system senses any overheating or fire in the power pack compartment. It will not give a warning if a short circuit occurs or if a fault develops, in the power supply or control unit. It is, therefore, essential that the system be tested daily.

14 Incorporated in the circuit are a firewire sensing element loop, a control box with a circuit test switch, a warning horn, a flasher unit, and two warning lights. The warning light's which have red lenses are located one (Fig 1(2)) in front of the driver's position, the other (Fig 3(1)) centrally at the top front of the personnel compartment. The warning light in the personnel compartment is attached to a box in which a flasher unit is housed. When energized, the flasher unit causes the warning lights to flash.

15 An audible warning is given by the sounding of a horn, located below the driver's switchboard and by a buzz, which can be heard in all connected headphones.

16 If the automotive battery switch is off, the warning lights will not flash in the event of a fire or overheating or if the test switch is operated, the battery switch does not affect the audible warnings.

### Testing the circuit

17 Ensure that the automotive battery switch (Fig 11(2)) is 'ON'.

18 Connect headphones to the appropriate control boxes.

19 Operate the test switch (Fig 10(2)) and check that:

19.1 The warning horn sounds.

19.2 A warning buzz is heard in all connected headphones.

19.3 Both warning lights flash.

20 The test switch will not operate the warning units if:

20.1 There is no supply to the control box.

20.2 A short circuit exists in the sensing element loop or connecting circuit.

20.3 An open circuit exists in the loop or its connections.

20.4 The control box is defective.

21 If the warning units continue to function after releasing the test switch, it indicates that there is a low resistance leakage to earth due to contamination of the element connectors or termination fittings. To stop the warning signals the control circuit must be temporarily interrupted at the distribution panel located at the right of the driver's compartment. The procedure is as follows:

21.1 Distribution panel No. 6, Mk 1 (Fig 11) - release circuit breaker compartment cover (1), pull the button circuit breaker J to open the circuit breaker. Close the circuit breaker by pressing the button.

21.2 Report the fault immediately to REME. The vehicle should be VOR (Vehicle Off the Road) until the system has been rectified



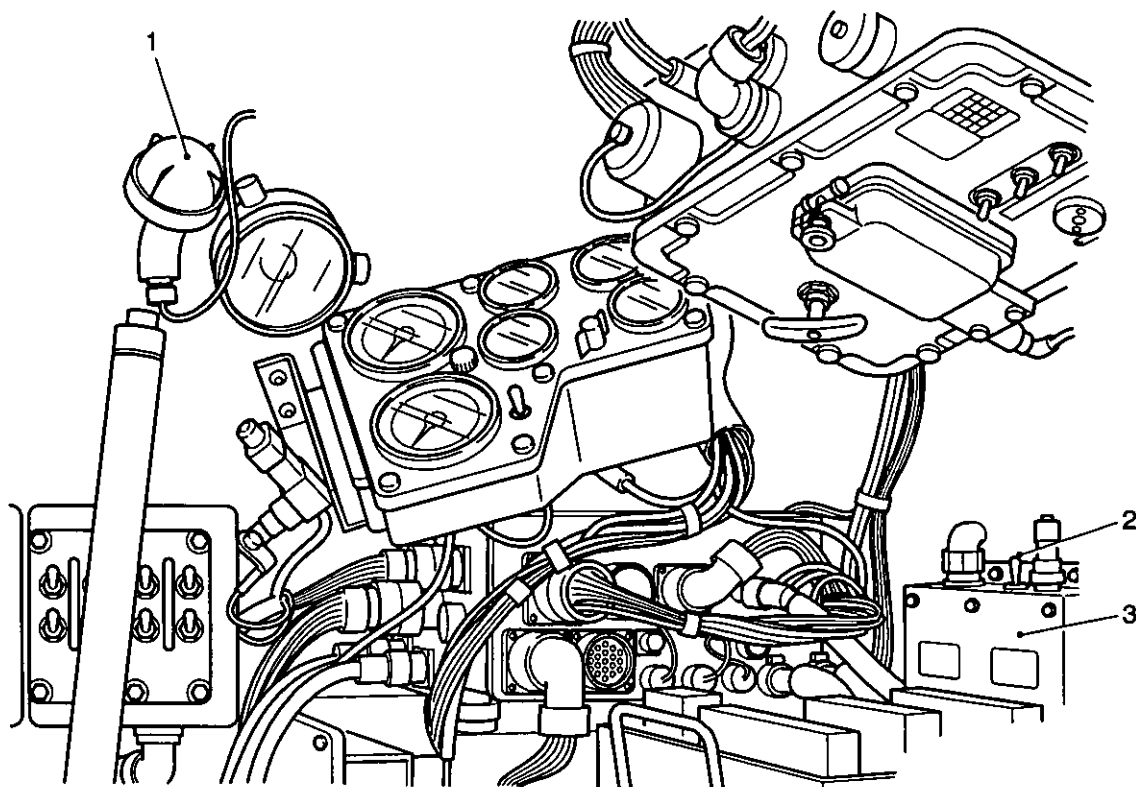

432/20105

- |   |                                  |   |                      |
|---|----------------------------------|---|----------------------|
| 1 | Fire warning light               | 3 | Firewire control box |
| 2 | Firewire control box test switch |   |                      |

Fig 10 Driver's controls and instruments

**ACTION IN THE EVENT OF FIRE****WARNINGS**

**(1) PERSONNEL SAFETY. IN THE EVENT OF A FIRE ENSURE ALL PERSONNEL HAVE BEEN EVACUATED FROM THE VEHICLE AND THAT ALL NON-ESSENTIAL PERSONNEL HAVE BEEN EVACUATED TO A SAFE AREA.**

**(2) ASPHYXIATION HAZARD. THE VAPOURS OF ALL FIRE EXTINGUISHERS DISPLACE AIR AND CAN CAUSE ASPHYXIA IN CONFINED SPACES. OPEN ALL HATCHES AND ALLOW TIME FOR FUMES TO DISPERSE BEFORE PERSONNEL RE-ENTER THE VEHICLE.**

22 In all cases of fire:

22.1 Stop the vehicle.

22.2 Stop the engine.

22.3 Turn both battery switches to 'OFF'.

23 The senior person present must take charge of the fire fighting operation and direct it according to the nature of the fire.

**External fires, driver's and personnel compartment fires**

24 Use the portable extinguishers.

## Power pack compartment fires

### WARNING

(1) **PERSONNEL SAFETY. IN THE EVENT OF A FIRE ENSURE ALL PERSONNEL HAVE BEEN EVACUATED FROM THE VEHICLE AND THAT ALL NON-ESSENTIAL PERSONNEL HAVE BEEN EVACUATED TO A SAFE AREA**

(2) **ASPHYXIATION HAZARD. THIS EQUIPMENT CONTAINS A HECTOFLUOROPROPANE (FM 200) FIRE SUPPRESSED SYSTEM. IF FM 200 VAPOUR IS BREATHED, IT CAN CAUSE SUFFOCATION. ONLY TRAINED PERSONNEL UNDER SUPERVISION ARE ALLOWED TO WORK ON THE SYSTEM. ANYONE WHO HAS BREATHED FM 200 VAPOUR IS TO RECEIVE MEDICAL ATTENTION.**

25 If the warning device operates or flames are seen, discharge one cylinder. If after the first cylinder has discharged the fire persists, discharge the second cylinder.

26 If no warning is given but smoke is seen, stop the vehicle, stop the engine, turn both battery switches to OFF and investigate carefully. If investigation is impracticable or if smoke persists or increases, discharge one or, if necessary, both cylinders.

### MAINTENANCE

#### Checking a portable fire extinguisher

27 Remove the extinguisher from its bracket and examine for damage.

28 Check the striker knob on the internally mounted portable extinguishers, if it can be turned by finger and thumb, or has been pushed in, the extinguisher should be discarded and a replacement obtained.

#### NOTE

On earlier types of extinguisher, apply thumb pressure to white spot on domed top. Renew extinguisher if spot remains pressed in.

29 Check that the discharge nozzle is clear.

#### NOTE

The extinguishers are sealed and cannot be dismantled for further examination.

30 Check that each externally mounted portable extinguisher is fully charged by reading the indicator gauge (Fig 6(3)), which should be indicating in the 'GREEN' range.

#### Servicing the fixed fire extinguisher system

31 Check that each cylinder (Fig 7(4)) is secure in its mounting.

32 Check that each cylinder is fully charged by checking the gauge is indicating in the green range. If the indicator is outside of the green range the cylinder must be changed.

#### NOTE

Crew must not attempt to remove a discharged or partially discharged cylinder, but at the first opportunity, report the condition of the cylinder to REME. The vehicle shall be VOR (Vehicle off the road) until the fault has been rectified.

33 Check that the cable connections to the remote control handles are in order.

34 Test the alarm system see Para 17 to 21.

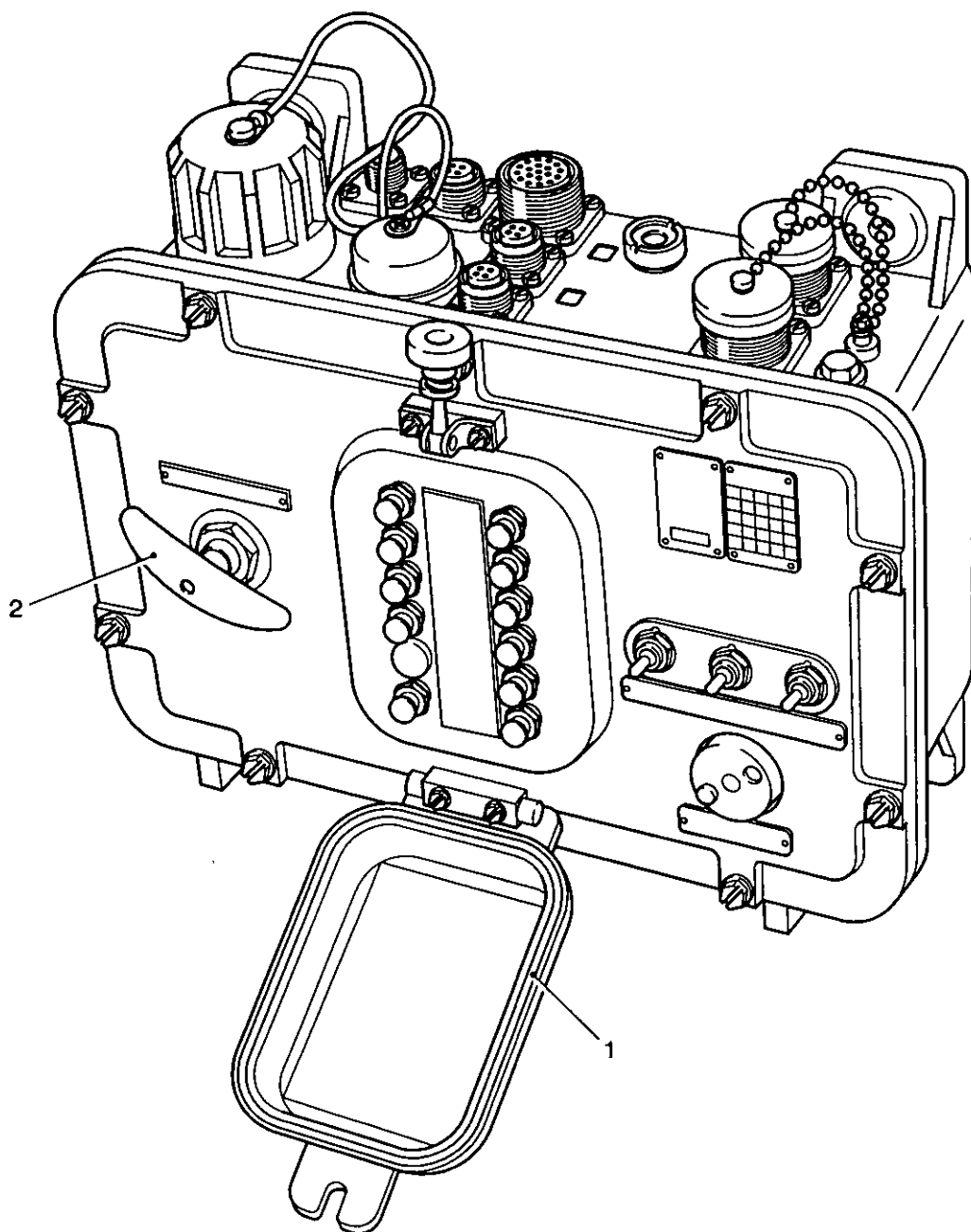

432/038

1 Circuit breaker compartment cover

2 Battery master switch

Fig 11 Distribution panel No. 6, Mk 1

**CHAPTER 2-2**  
**HULL AND FITTINGS**  
**CONTENTS**

Para	
	Introduction
1	General
	Driver's compartment
2	Driver's hatch
3	Driver's periscope
5	Periscope/windscreen washer
6	Filling the fluid container
7	Operating the washer
9	Cleaning the nozzle
10	Pump unit
11	Removing and replacing the driver's periscope (CAUTION)
12	Driver's seat
15	Seat adjustment
16	Fitting the harness
17	Releasing the harness
18	Seat Maintenance
20	Driver's controls and instruments
21	Steering/brake levers
22	Parking control
23	Accelerator pedal
24	Engine fuel stop control
25	Engine speed hand control
26	Gear range selector level
27	Engine/transverse gearbox dis-connector access cover
28	Driver's periscope screen washer control handle
29	Dipswitch
30	Horn push button
31	Instrument panel
32	Driver's switchboard
33	Fire alarm horn
34	Firewire control box
35	Fire alarm warning light
36	Distribution link box
37	Distribution panel No. 6 Mk 1
38	Power pack access plate (engine covers)
39	Removing and replacing the plate (CAUTION)
	Commander's compartment
40	Commander's cupola hatch
41	Cupola
45	Removing and replacing the commander's periscope (CAUTION)
46	Commander's seat
49	Maintenance
	Commander's instruments and controls
50	Vacuum/pressure gauge, air conditioning
51	Test button, Ventilation system
52	Ventilation fan, speed control
53	Auxiliary junction box
54	Smoke discharger switches
55	Radio distribution box (Mk2 and Mk2/1)

(continued)

## CONTENTS (continued)

Para		
	Personnel compartment	
56	Personnel seats (WARNING)	
57	Maintenance	
58	Rear door	
62	Mortar hatch	
63	Opening the hatch (WARNING) (CAUTION)	
64	Closing the hatch	
65	Interior lights blackout switch	
66	Fire alarm warning light	
67	Communication equipment	
68	Power pack access	
69	Air inlet and outlet louvres	
72	Steering unit access cover (WARNING)	
73	Smoke grenade dischargers	
74	To load (WARNINGS)	
75	To fire	
76	Misfire	
77	To unload (WARNINGS)	
79	After firing	
80	High visibility marker boards	
82	Fuel system (WARNINGS)	
83	Fuel tanks	
86	Filling the fuel tanks	
87	Draining the fuel tanks	
88	Collector tank	
89	Draining water from the collector tank	
	Maintenance	
90	Checking and topping up the governor oil level	
	Hull Maintenance	
91	Draining the vehicle hull (WARNING)	
92	Hull details lubrication	
93	Mount, gun, 7.62 mm, No. 3 Mk 1 (CAUTION)	
105	Mounting the GPMG	
107	Removing the GPMG	
108	Securing the GPMG for travelling	
109	Positioning the spent case bin	
110	Removing the spent case bin	
111	Servicing and maintenance	
Table		Page
1	Washer fluid mixture ratios .....	6
Fig		Page
1	Hull external fittings (Mk 2 vehicle) .....	4
2	Hull hatches .....	5
3	Driver's hatch (closed) and Cupola .....	7
4	Driver's seat .....	9
5	Radio batteries (Maintenance free) .....	10
6	Driver's compartment .....	11
7	Engine/transverse gearbox dis-connector control handle .....	12
8	Drivers controls and instruments .....	13
9	Instrument panel .....	14
10	Driver's switchboard .....	14

(continued)

CONTENTS (continued)

Fig		Page
11	Distribution panel No. 6 Mk 1 .....	16
12	Cupola and driver's hatch (closed) .....	18
13	Commander's seat .....	19
14	Radio distribution box (Mk 2 vehicles) .....	20
15	Auxiliary junction box .....	21
16	Interior of vehicle from rear (Mk 2 vehicles) .....	22
17	Interior of vehicle from driver's compartment .....	23
18	Rear of vehicle .....	23
19	Mortar hatch external view .....	24
20	Communication equipment .....	26
21	Power pack covers .....	27
22	Fuel system schematic .....	30
23	Location of fuel filler cover .....	31
24	Hull bottom plate .....	32
25	Fuel tank drain valve .....	33
26	Fuel collector tank .....	34
27	Injection pump governor .....	35
28	Mount, gun, 7.62 mm No. 3 Mk 1 .....	37/38

INTRODUCTION

General

1 The hull is a welded structure fabricated from armour plate, divided into four main compartments by transverse and longitudinal bulkheads. The four main compartments are as follows:

1.1 Driver's compartment. The driver's compartment is located at the front of the RH side of the hull, covered by an overhead armoured glacis plate. The glacis plate contains a rectangular shaped hole, which provides normal access to the compartment. The access hole is closed by an armoured hatch (Fig 2(3)). The hatch is fitted with a wide angled periscope (Fig 2(4)). The driver's seat can be adjusted to facilitate varying driving positions and to permit emergency evacuation through the rear of the compartment.

1.2 Commanders compartment. The commander's compartment is located directly behind the driver's compartment on the RH side of the hull, covered by an overhead armoured roof plate. The roof plate contains a circular shaped hole, which provided normal access to the compartment. The access hole is closed by an armoured hatch mounted on the cupola (Fig 2(5)). The cupola has a 360 deg rotation, with three periscopes (7), both outer periscopes fixed. Centre AFV No. 32 Mk 1 periscope can be pivoted axially in vertical plane. A mount (6) for a (GMPG) general-purpose machine gun is also provided. The commander's seat can be adjusted to facilitate varying positions and to permit emergency evacuation through the rear of the compartment.

1.3 Personnel Compartment. The personnel compartment is located behind the commander's and power pack compartments and extends the full width of the hull, covered by an armoured roof plate. The armoured roof plate has an aperture to accommodate the mortar hatch (Fig 2(8)). The rear hull plate has a rectangular aperture to accommodate the rear door. Normal access to the personnel compartment is through the rear door centrally located in the rear hull plate. The compartment provides seating for ten personnel on inward facing bench seats on either side of the compartment.

1.4 Power pack compartment. The power pack compartment is located at the front LH side of the hull, covered by overhead armoured glacis and roof plates. Access covers (Fig 1(6) and Fig 2(1)), air intake and out louvres are located in the roof plates. The compartment houses the power pack.

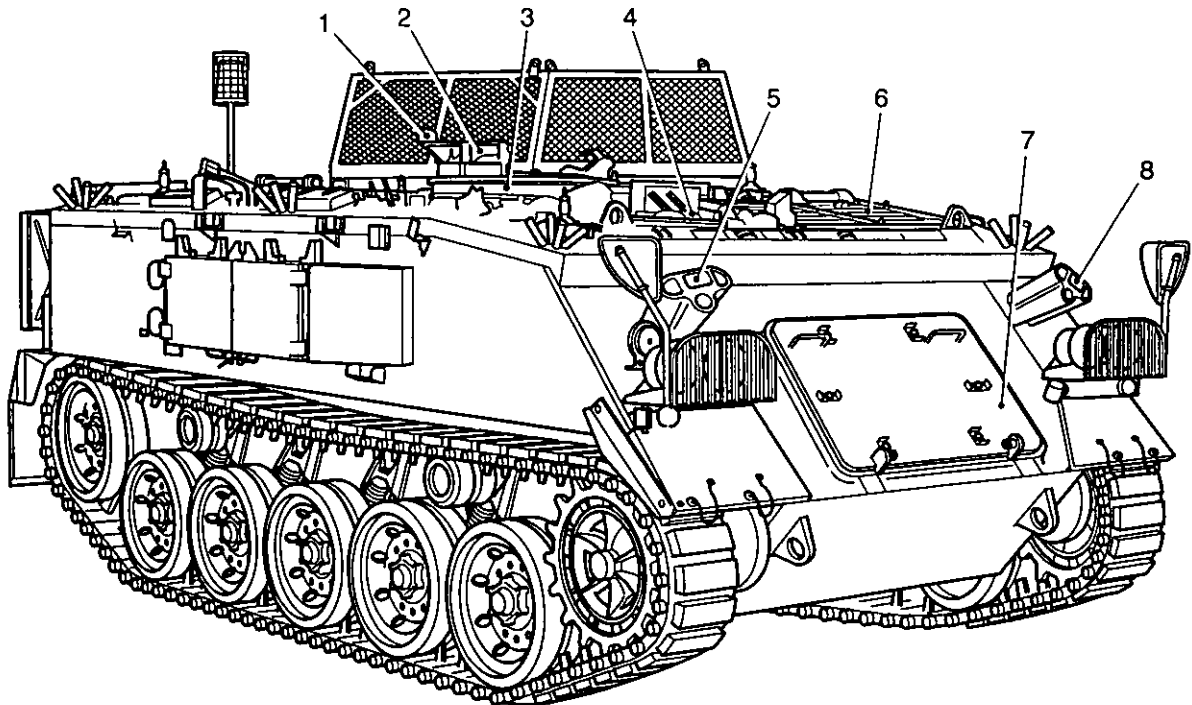

432/20115

- |   |                               |   |                            |
|---|-------------------------------|---|----------------------------|
| 1 | GPMG Mount                    | 5 | RH Smoke discharger        |
| 2 | Commander's periscopes Cupola | 6 | Power pack covers          |
| 3 | Cupola                        | 7 | Steering unit access cover |
| 4 | Driver's periscope            | 8 | LH Smoke discharger        |

Fig 1 Hull external fittings (Mk 2 vehicle)

## DRIVER'S COMPARTMENT

### Driver's Hatch

2 The door of the driver's hatch (Fig 2(3)) is spring assisted in opening and is locked when closed, by a locking catch (Fig 3(12)), which can be operated only from inside the vehicle. The door carries a wide-angle periscope (Fig 2(4)) for closed down driving. A spring-loaded catch retains the door in the open position (Fig 2(2)).

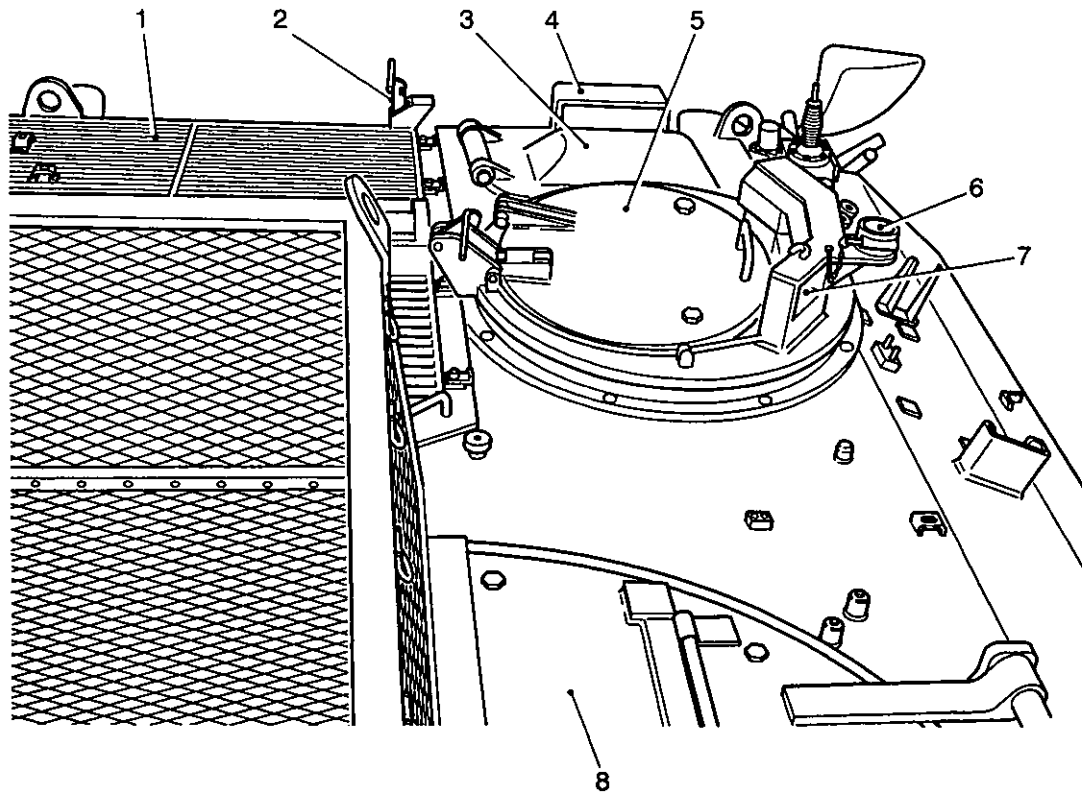

430/20116

- 1 Power pack covers
- 2 Driver's hatch catch
- 3 Driver's hatch
- 4 Driver's periscope

- 5 Commander's hatch
- 6 GPMG Mount
- 7 Commander's periscopes
- 8 Mortar hatch

Fig 2 Hull hatches

### Driver's periscope

3 The driver's hatch carries a wide-angle periscope (Fig 2(4)) for closed down driving.

4 The periscope wiper blades can be operated manually by the wiper manual control handle (Fig 3(18)), or electrically by a motor (20) attached to the door. For the manual operation move the wiper manual control handle back and forth as necessary to obtain a clear field of view. For the motor operation, with the battery and engine switches ON, move the wiper manual control parking handle to the left away from the parked position, then operate the wiper motor switch.

### NOTE

In the parked position, the wiper motor switch is locked in the OFF position.

### Periscope/windscreen washer

5 The periscope washer is operated manually by a screen washer control handle (16) in the head of the container, which is located on the left in front of the driver. The container can be filled through a hole in the container head after removing a rubber bung.

### Filling the fluid container

6 Remove the rubber filler bung from the pump unit and pour in washer fluid (mixed dependant upon temperature, in compliance with Table 1) until the tank is filled to the level of the filler opening. Ensure that dirt, oil or grease does not enter the tank.



TABLE 1 WASHER FLUID MIXTURE RATIOS

Freezing point of mix (approx) Deg C (1)	MOD Screen wash (2)	Parts water (3)	Parts AL11 (4)
-5	1	8	1
-10	1	7.5	1.5
-12.5	1	6.5	2.5
-15	1	6	3
-17.5	1	3	6

## NOTE

- (1) Soft or distilled water must be used whenever possible. If an emergency arises and water from another source is used, it is essential that it is perfectly clean.
- (2) Below -17.5 deg C AL11 should not be diluted.
- (3) If the pump fails a new container (reservoir) and pump, are to be fitted in accordance with AESP 2350-T-250-821 Gen Instr No 1/60.

Operating the washer

7 Pull the handle (Fig 3(16)) steadily, hold it a moment, and then release it. The return action is spring operated, therefore the handle MUST NOT be pushed back, or damage may be caused.

## NOTE

If the handle does not return, there is an obstruction in the system, possibly due to dirt at the nozzle. To clean the nozzle, see Para 9.

8 While the spray is operating switch 'ON' the wiper motor; switch 'OFF' when the spray ceases.

Cleaning the nozzle

9 The procedure for cleaning the nozzle is as follows:

- 9.1 Remove the nozzle and the nozzle-sealing washer from the jet unit.
- 9.2 Blow air through the nozzle in the reverse direction to the fluid flow until the nozzle is cleared.
- 9.3 Operate the control handle two or three times to flush out the system.
- 9.4 Replace the nozzle and sealing washer then check efficient operation.

Pump unit

10 Should the pump unit become clogged by dirt or a sticking valve, report to REME.

**Removing and replacing the driver's periscope**

11 The procedure for removing and replacing the driver's periscope, is as follows:

- 11.1 Slacken the knurled nuts (Fig 3(19)) at the bottom of the supporting lugs.
- 11.2 Swing the lower part of the periscope forward to clear the lugs, and then lower the periscope from the mounting.
- 11.3 Clean the inside of the periscope aperture and wipe with a lightly oiled clean cloth.

11.4 Any mud or dirt accumulated on the periscope glass surfaces must be washed off with clean water and the surfaces dried with a clean cotton rag. On no account should mud or dirt be removed in a dry condition.

**CAUTION**

**EQUIPMENT DAMAGE.** The glass surfaces must be kept perfectly clean they must not be touched directly with the fingers.

11.5 Replace the periscope in the reverse sequence, taking care not to damage the wiper blades.

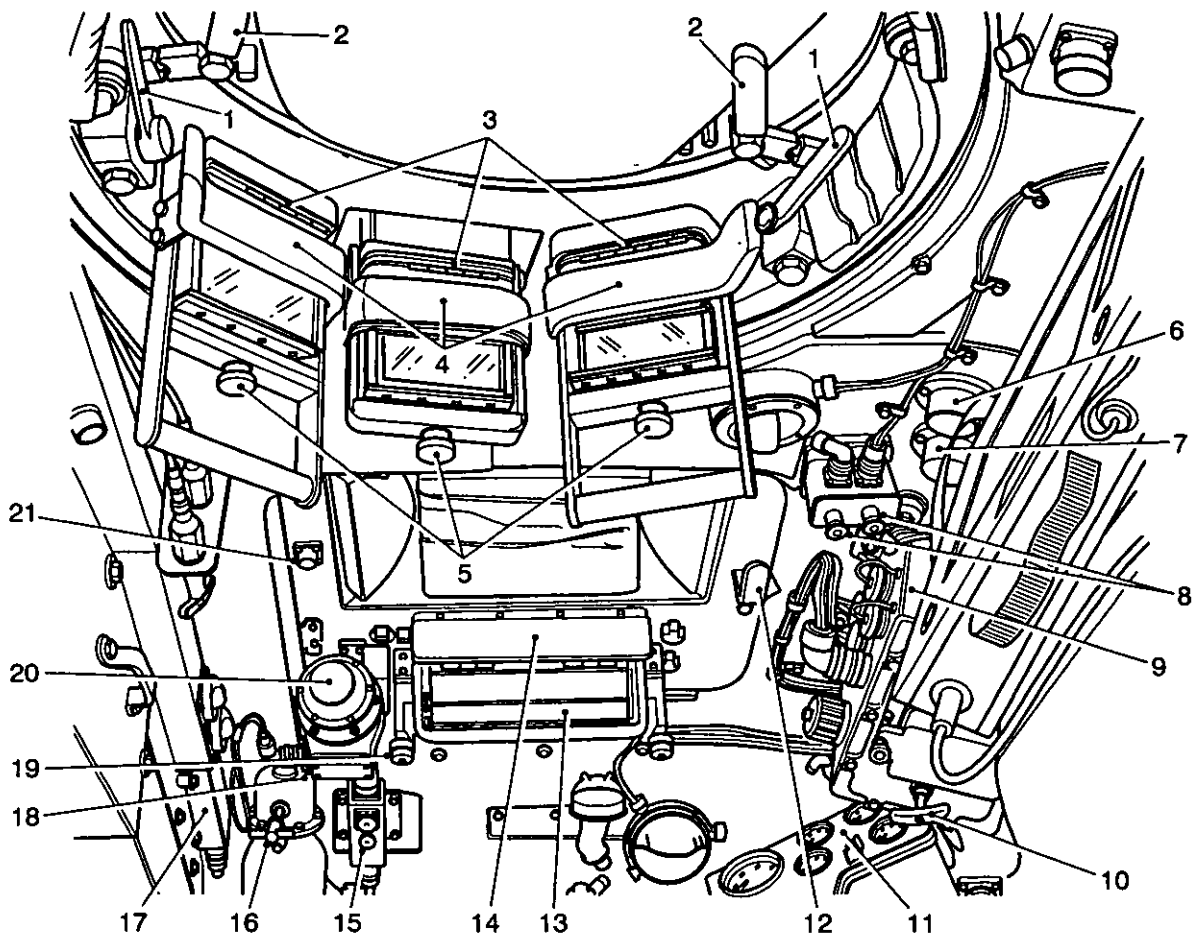

430/20117

- |    |                                |    |                              |
|----|--------------------------------|----|------------------------------|
| 1  | Clamp handles                  | 12 | Locking catch                |
| 2  | Cupola door catches            | 13 | Driver's periscope           |
| 3  | Periscope casing locking catch | 14 | Brow pad                     |
| 4  | Brow pad                       | 15 | Wiper switch                 |
| 5  | Knurled screws                 | 16 | Screen washer control handle |
| 6  | Radio battery flame trap       | 17 | Filter unit                  |
| 7  | Automotive battery flame trap  | 18 | Wiper manual control handle  |
| 8  | Smoke discharger switches      | 19 | Knurled nut                  |
| 9  | Distribution box No. 6 Mk 1    | 20 | Wiper motor                  |
| 10 | Master Switch                  | 21 | Dummy socket                 |
| 11 | Instrument panel               |    |                              |

Fig 3 Driver's hatch (closed) and Cupola

**Driver's seat**

12 The driver's seat (Fig 4) is designed for opened up or closed down driving and can be tilted forward to give access to the batteries underneath it. Hinged at the back of the frame is the commander's footrest (5).

13 The backrest has two locations and can also be tilted or lowered completely to allow access from the rear.

14 A safety harness is fitted to the backrest and anchored to the roof and when in use restrains the driver from uncontrollable movement while travelling.

#### Seat adjustment

15 Adjust the seat as follows:

15.1 To adjust the seat for height, ease the weight of the body from the seat and push forward the height adjusting lever (Fig 4(4)) on the right, press down the seat or allow it to rise until the desired position is reached, then release the lever. Six positions are obtainable.

15.2 To move the seat backward or forward, depress the longitudinal adjustment bar (2) located along the bottom front of the seat and slide the seat to the required position. Release the bar and ensure that the catches re-engage. The seat can be slid rearwards until it is completely clear of the slides.

15.3 To locate the backrest in either position, lift it and move it forward or backward.

15.4 To adjust the tilt of the backrest, press down the backrest-adjusting lever (7) on the right of the backrest, tilt the backrest to one of five positions, and then release the lever.

15.5 To lower the backrest, press the lever on the right of the backrest and lower the backrest to the horizontal position.

15.6 To obtain access to the radio batteries, remove the bolts, one either side, securing the supporting cross-member then tilt the seat upwards and forwards (see Fig 5(1)).

#### NOTE

The vehicle may be fitted with maintenance free batteries and the individual battery cells cannot be refilled.

#### Fitting the harness

16 The procedure for fitting the harness (Fig 4(1)) is as follows:

16.1 Check harness for serviceability (Para 19 refers), if found unserviceable, report.

16.2 Move the two parts of the harness to each side clear of the seat.

16.3 Sit in the seat.

16.4 Place the arms under the shoulder straps and arrange the straps in front of the body.

16.5 Draw together the two parts of the quick-release buckle and engage them, then press the handle so that it lies flush with the rest of the buckle.

#### Releasing the harness

17 Lift the quick-release buckle handle marked 'LIFT'. Slip the shoulder straps off the shoulders.

#### Seat Maintenance

18 User maintenance to the driver's seat is restricted to checking the security of the seat mounting fixtures, ensuring all sliding surfaces and pivot points are lightly oiled and that all catches, locking levers and operating mechanisms operate correctly.

19 User maintenance for the safety harness is restricted to checking the security of the mounting screws and the belts for chaffing and freedom of movement. Check the operation of the quick release buckle mechanism.

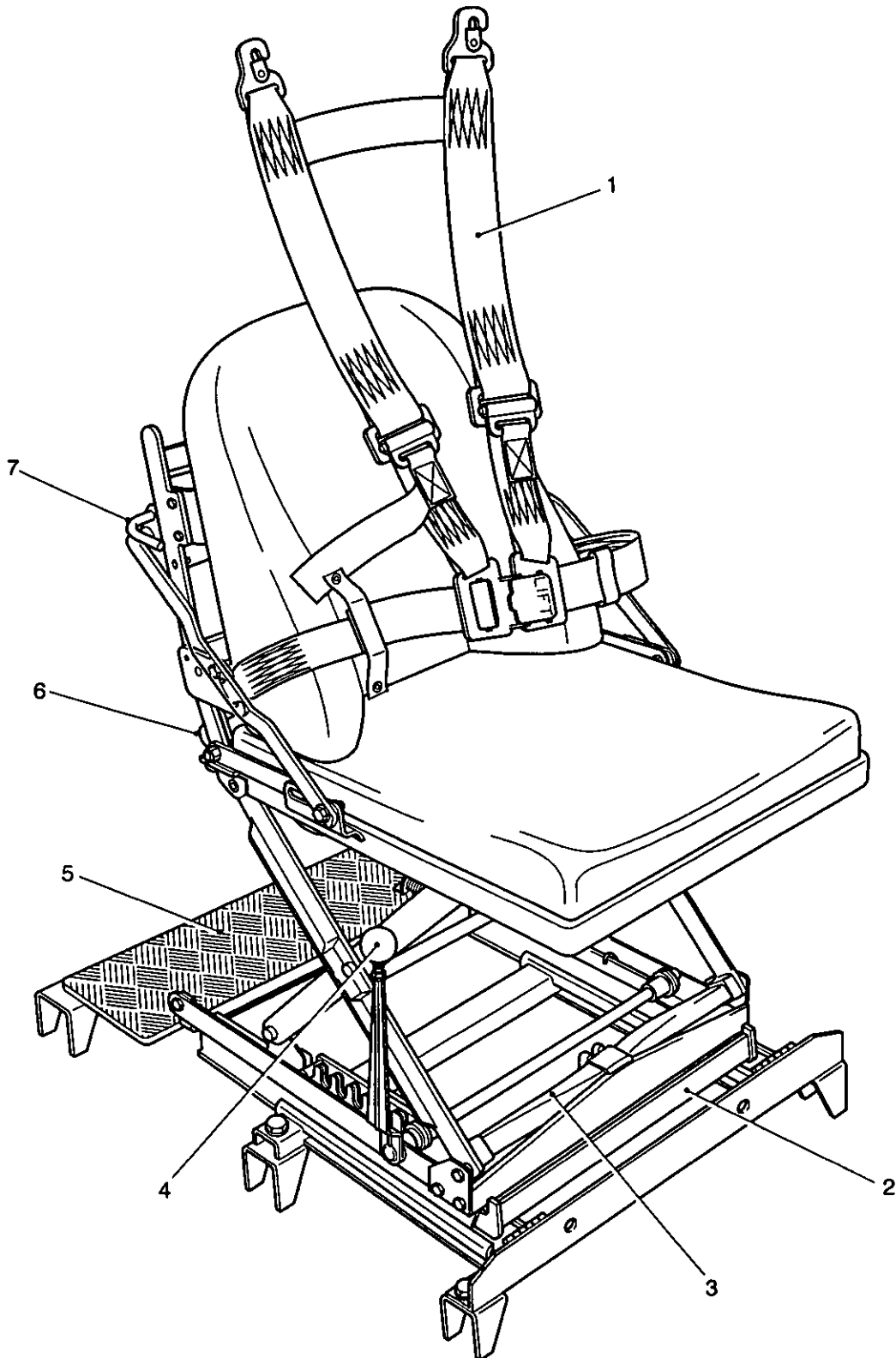

432/044a

- |   |                             |   |                                  |
|---|-----------------------------|---|----------------------------------|
| 1 | Harness                     | 5 | Commander's footrest             |
| 2 | Longitudinal adjustment bar | 6 | Throw-over link positioning seat |
| 3 | Torsion bar                 | 7 | Backrest adjusting lever         |
| 4 | Height adjusting lever      |   |                                  |

Fig 4 Driver's seat

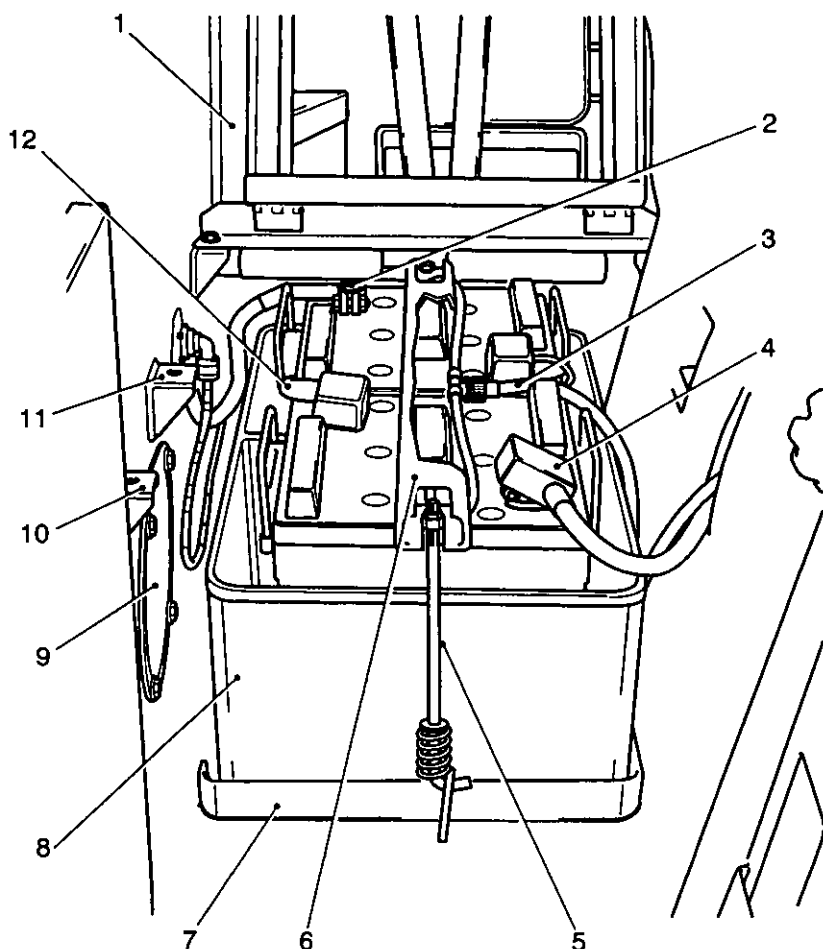

430/20087

1	Seat frame	7	Container housing frame
2	Negative terminal	8	Container
3	Vent tube assembly	9	Access plate, gearbox filter
4	Rubber cover	10	Footrest bracket
5	Battery clamp bolt	11	Seat bracket
6	Battery clamp bar	12	Inter-connector

Fig 5 Radio batteries (Maintenance free)

**Driver's controls and instruments**

20 Drivers controls, instruments and layout of the drivers compartment are illustrated in figures 6 and 8.

Steering/brake levers

21 The steering/brake levers (Fig 6(3)) are mounted to the hull floor in front of the driver, a mechanical linkage connects the levers to the steering unit brake mechanism. The levers are used to steer and brake the vehicle.

Parking control

22 The parking control button protrudes through a screwed cap (Fig 8(14)) on the upper end of each steering/brake lever. It is a 'spring loaded' plunger, which is applied; when the brake/steering levers are fully applied, the buttons are depressed to locked into position. To release the plunger locks pull backwards on the levers and press the buttons. This will release the levers for normal operation.

Accelerator pedal

23 The accelerator pedal (Fig 6(6)) is located by the driver's right foot and is mechanically linked to the power pack to control engine speed.

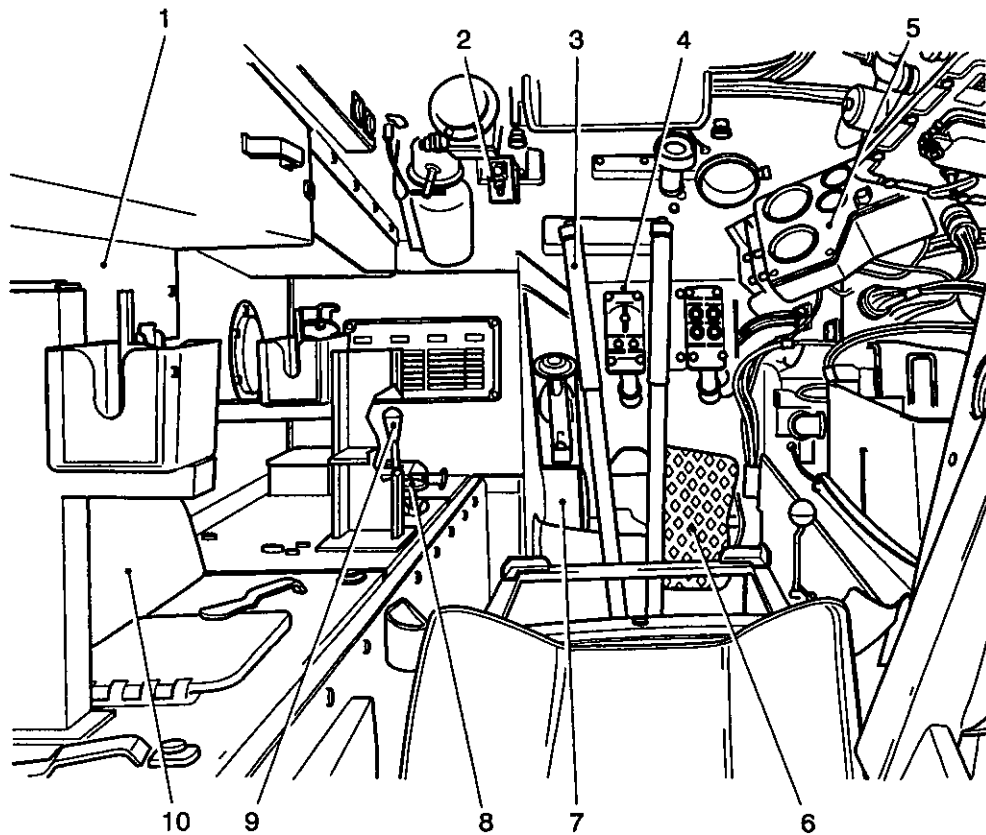

432/20118

- |   |                                       |    |                                       |
|---|---------------------------------------|----|---------------------------------------|
| 1 | Power pack access plate upper section | 6  | Accelerator pedal                     |
| 2 | Wiper sight switch                    | 7  | Engine fuel stop control              |
| 3 | Steering/brake levers                 | 8  | Engine speed hand control             |
| 4 | Driver's switchboard                  | 9  | Gear range selector lever             |
| 5 | Instrument panel                      | 10 | Power pack access plate lower section |

Fig 6 Driver's compartment

Engine fuel stop control

24 The engine fuel stop control (Fig 6(7)) is the pedal located by the driver's left foot. It is mechanically linked to the engine, depressing the control pedal stops the engine by cutting its supply of fuel.

Engine speed hand control

25 The engine speed hand control (8) is mounted at the front of the power pack compartment sill. The control permits independent control of engine speed when the vehicle is stationary to charge automotive, ventilation and radio batteries.

Gear range selector lever

26 The gear range selector lever (9) is mounted to the left of the driver on the power pack compartment sill. The gear range selector lever is mechanically linked to the vehicle gearbox and can be shifted to pre select a required gear range. The gear ranges, which can be selected, are 1-2, 3-4, 3-5, 3-6, neutral and reverse. To engage the select lever in the reverse slot it is necessary first to pull the reverse stop knob out.

Engine/transverse gearbox dis-connector access cover

27 Engine/transverse gearbox dis-connector control handle (Fig 7(4)) is located under the hinged cover (1) at the rear end of the power pack sill. The dis-connector is used to facilitate engine starting whilst either cold starting or being slave started by dis connecting the drive between the transmission and engine.

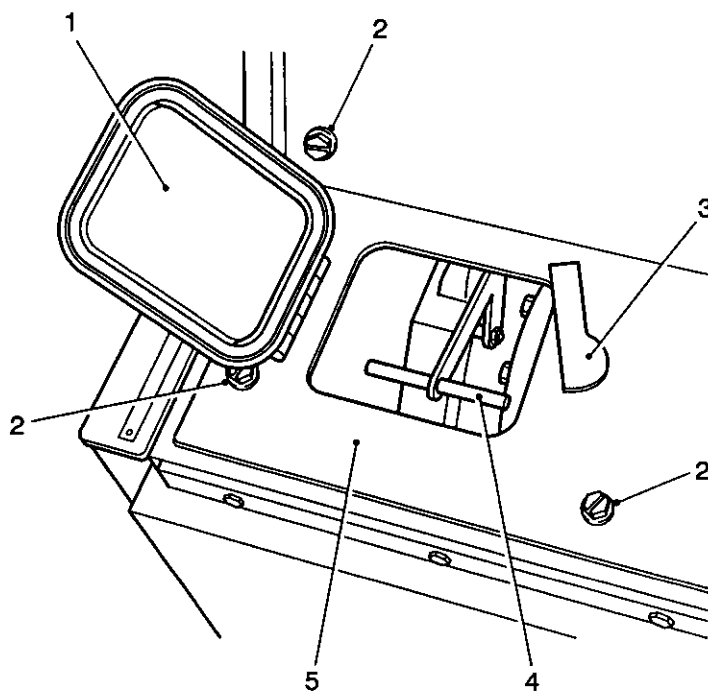

432/048

- |   |            |   |                              |
|---|------------|---|------------------------------|
| 1 | Cover      | 4 | Dis-connector control handle |
| 2 | Turn catch | 5 | Power pack partition plate   |
| 3 | Catch      |   |                              |

Fig 7 Engine/transverse gearbox dis-connector control handle

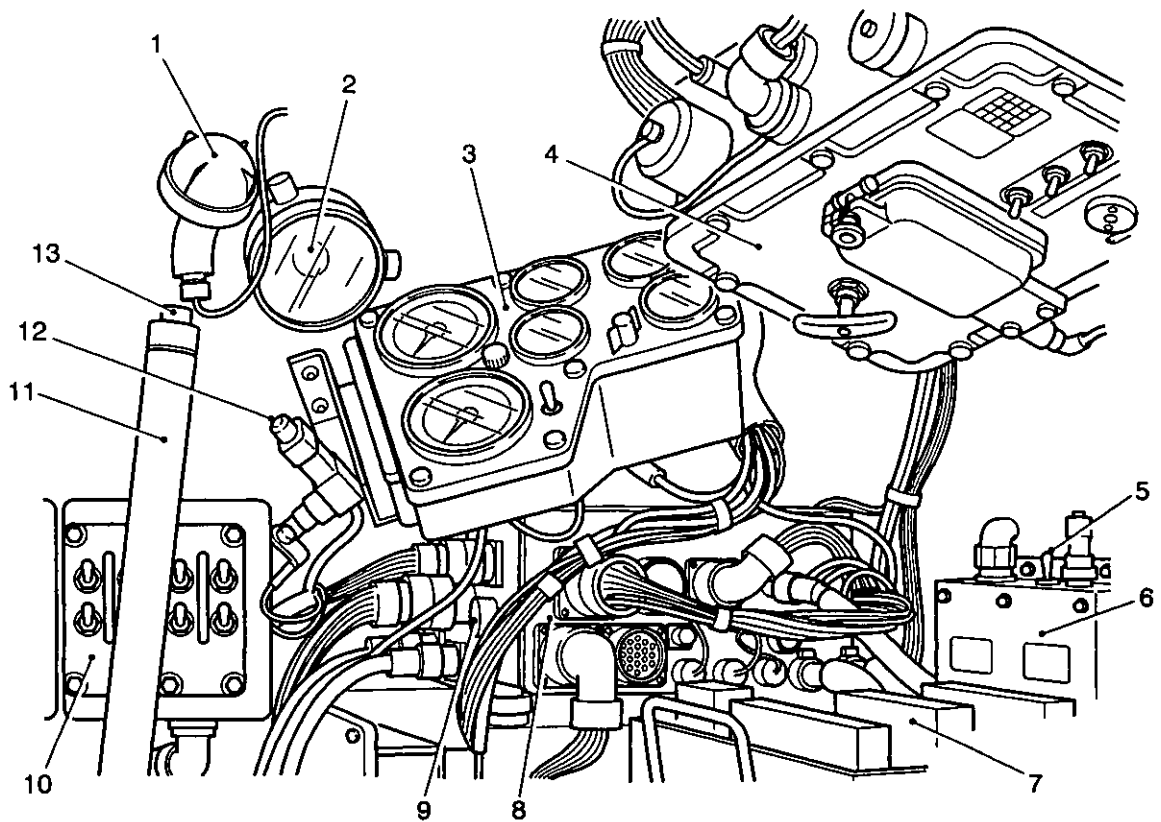

432/20119

- |   |                                  |    |                                     |
|---|----------------------------------|----|-------------------------------------|
| 1 | Fire warning light               | 8  | Distribution link box               |
| 2 | Interior light                   | 9  | Distribution link box warning light |
| 3 | Instrument panel                 | 10 | Driver's switchboard                |
| 4 | Distribution panel               | 11 | Steering/brake lever                |
| 5 | Firewire control box test switch | 12 | Horn push                           |
| 6 | Firewire control box             | 13 | Parking control button              |
| 7 | Automotive batteries             |    |                                     |

Fig 8 Driver's controls and instruments

#### Driver's periscope screen washer control handle

28 The washer unit is mounted on the sloping roof plate in front of the driver see Para 7 for operation. It should be noted that, dependant on the type of washer fitted as to where the switch is mounted (See note 2 at para 6).

#### Dipswitch

29 The dipswitch is the foot-operated switch on the floor adjacent to the driver's left foot. With the headlights switched on, operation of the switch changes the light beams of the headlight from main to dip or vice versa. A warning light on the turn-light switch glows when the main beams are on.

#### Horn push button

30 The horn push (Fig 8(12)) is located to the right of the driver's switchboard. It is a push type switch controlling the traffic horn.

#### Instrument panel

31 The instrument panel (Fig 8(3)) is mounted to the right of the driver's switchboard and houses instruments related to the power pack and vehicle speed illustrated in Fig 9.



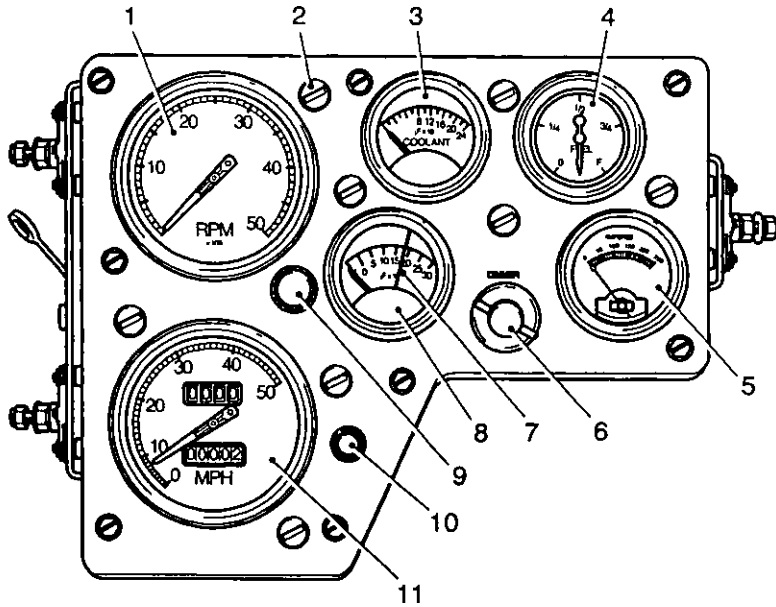

432/085

- |   |                           |    |                                     |
|---|---------------------------|----|-------------------------------------|
| 1 | Tachometer                | 6  | Panel lights switch                 |
| 2 | Panel light               | 7  | Safe Working temperature indicator  |
| 3 | Coolant temperature gauge | 8  | Gearbox oil temperature gauge       |
| 4 | Fuel gauge                | 9  | Fuse                                |
| 5 | Ammeter                   | 10 | Speedometer trip reading reset knob |
|   |                           | 11 | Speedometer                         |

Fig 9 Instrument panel

Driver's switchboard

32 The driver's switchboard (Fig 10) is located in front of the driver; it mounts the turn light switch (1), engine switch (6) and external lighting (4) switchboards.

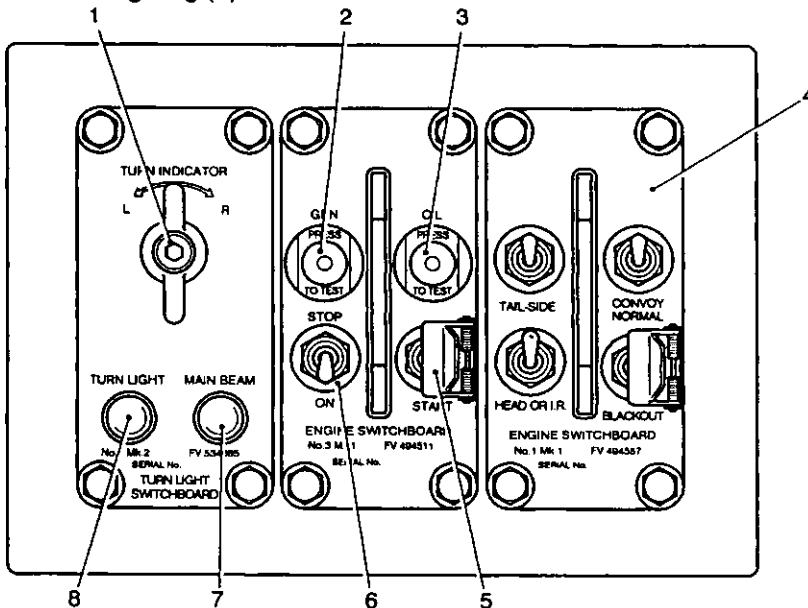

432/456

- |   |                                |   |                          |
|---|--------------------------------|---|--------------------------|
| 1 | Turn light switch              | 5 | Starter switch           |
| 2 | Main indicator (GEN)           | 6 | Engine switch            |
| 3 | Low oil pressure warning light | 7 | Main beam warning light  |
| 4 | External lighting switchboard  | 8 | Turn light warning light |

Fig 10 Driver's switchboard

Fire alarm horn

33 The fire alarm horn is located on the front sloping plate below the driver's switchboard and marked FIRE ALARM.

Firewire control box

34 The firewire control box (Fig 8(6)) is mounted on the vehicle RH side plate adjacent to the automotive batteries. The control box houses the fire alarm system test switch (5).

Fire alarm warning light

35 The fire warning light (Fig 8(1)), fitted with a red lens, is located in front of the driver.

Distribution link box

36 The distribution link box (Fig 8(8)) is located immediately below the instrument panel. A small press to test warning light (9) is fitted to the left side of the link box. Under normal conditions, with the alternators charging, the light is dim. If the radio batteries positive line is earthed, the light is bright. If the radio battery connections are reversed, the light is bright before the engine is started, if the engine is started in this condition the lamp will glow excessively and burn out. Internal damage will also be caused to the charging system.

Distribution panel No. 6 Mk 1

37 On later vehicles the distribution panel No. 5 Mk 1 and the accessories control box were replaced by the distribution panel No. 6 Mk 1 (Fig 11). The battery master switch (11) on this panel controls both the automotive and the ventilation batteries and the fuses were replaced by Circuit Breakers (CBs). The panel is mounted on the roof plate to the right of the driver.

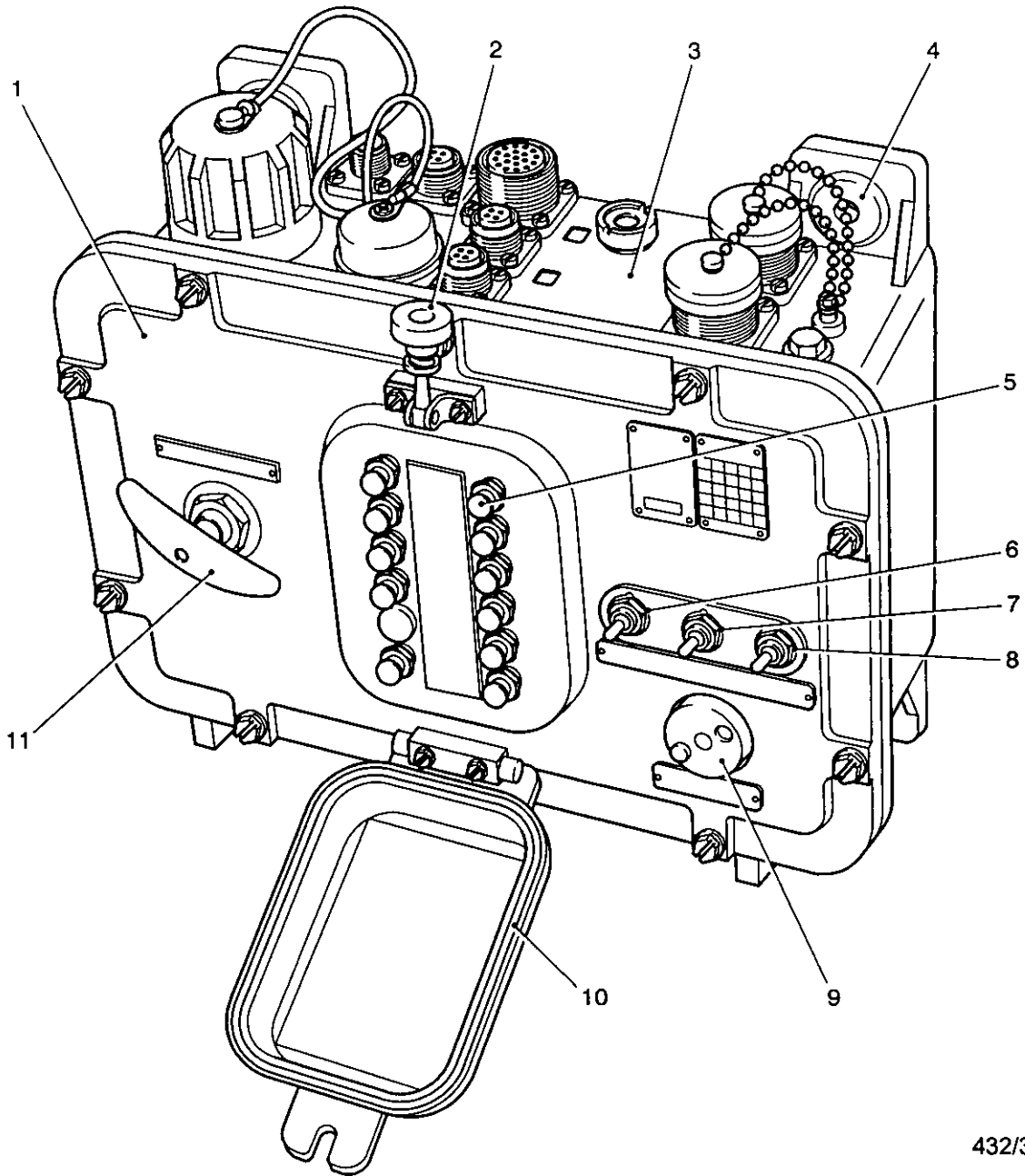

432/342

- |   |                          |    |                       |
|---|--------------------------|----|-----------------------|
| 1 | Cover                    | 7  | NBC ON                |
| 2 | Nut                      | 8  | External light switch |
| 3 | Metal case               | 9  | Battery selector      |
| 4 | Anti-vibration mounting  | 10 | Circuit breaker cover |
| 5 | Circuit breaker (11 off) | 11 | Battery switch        |
| 6 | CBR ON                   |    |                       |

Fig 11 Distribution panel No. 6, Mk 1

**Power pack access plate (engine covers)**

38 Access to the right side of the power pack is provided by a removable plate forming the rear part of the longitudinal partition. The plate is made in two sections secured by 18 turn catches, nine on the upper section (Fig 6(1)) and nine on the lower (10). The turn catches (Fig 7(2)) are fixed to hexagon heads on the outer side of the plate; each head has a saw-cut to indicate the position of the catch. The seal between the sections is made by four clamp plates attached to the lower section.

### Removing and replacing the plate

39 The procedure for removing and replacing the plate is as follows:

39.1 Ensure that the commander's cupola is positioned so that the periscope handles are not in the way when removing the access plate. Lower the driver's seat and backrest, remove the commander's seat backrest.

39.2 Release the four clamp plates sealing the joint between the two sections, turn the catches securing the upper section and lift the section away. Turn the catches securing the lower section and lift the lower section away.

### CAUTION

**EQUIPMENT DAMAGE.** Report immediately any signs of distortion or defects, which might impair the air seal. This is essential to prevent overheating power pack components.

39.3 Examine the seal and sealing surfaces and to refit the plate, proceed in the reverse sequence to that for removing.

### COMMANDER'S COMPARTMENT

#### Commander's Cupola Hatch

40 The commander's hatch (Fig 2(5)) in the top of the cupola (Fig 1 (3)) when closed is held by two door catches (Fig 12(2)). The catches can be operated only from inside the vehicle. A stop bracket and spring catch retains the door in the open position.

#### Cupola

41 The cupola (Fig 12) is rotatable through 360 deg to allow all round vision for the commander and full use of the Machine Gun (MG).

42 Three periscopes are mounted side by side on the cupola ring with the General Purpose Machine Gun (GPMG) pintle-mounting bracket welded to the guard over the periscopes. The outer periscopes have fixed positions but the middle periscope is capable of limited movement in the vertical plane.

43 A window is mounted on the periscope guard to cover the object glass of the left periscope. The window has a wiper operated by a flexible cable and torsion spring acting on the spindle of the wiper arm. To operate the wiper pull down the handle of the flexible cable then release it. The wiper arm returns under the action of the torsion spring.

44 The hinged door in the top of the cupola when closed is held by two rotatable catches (2). The catches can be operated only from inside the vehicle. A stop bracket and spring catch retains the door in the open position. The cupola can be locked against rotation by three clamps disposed equi-distant around the cupola ring. By turning down the clamp handles (1) from horizontal to vertical, the cupola is held from further rotation to retain a field of view.

### Removing and replacing the commander's periscope

45 The procedure for removing and replacing the commander's periscope, is as follows:

45.1 Unscrew the knurled screw (Fig 12(5)) in the supporting strap under the periscope. Support the periscope, swing the strap inwards and lower the periscope.

45.2 Clean the inside of the periscope aperture and wipe with a lightly oiled clean cloth.

45.3 Any mud or dirt accumulated on the periscope glass surfaces must be washed off with clean water and the surfaces dried with a clean cotton rag. On no account should mud or dirt be removed in a dry condition.

**CAUTION**

**EQUIPMENT DAMAGE.** The glass surfaces must be kept perfectly clean; they must not be touched directly with the fingers.

45.4 Replace the periscope in the reverse sequence, taking care not to damage the wiper blades.

45.5 Repeat the operations for the other two periscopes.

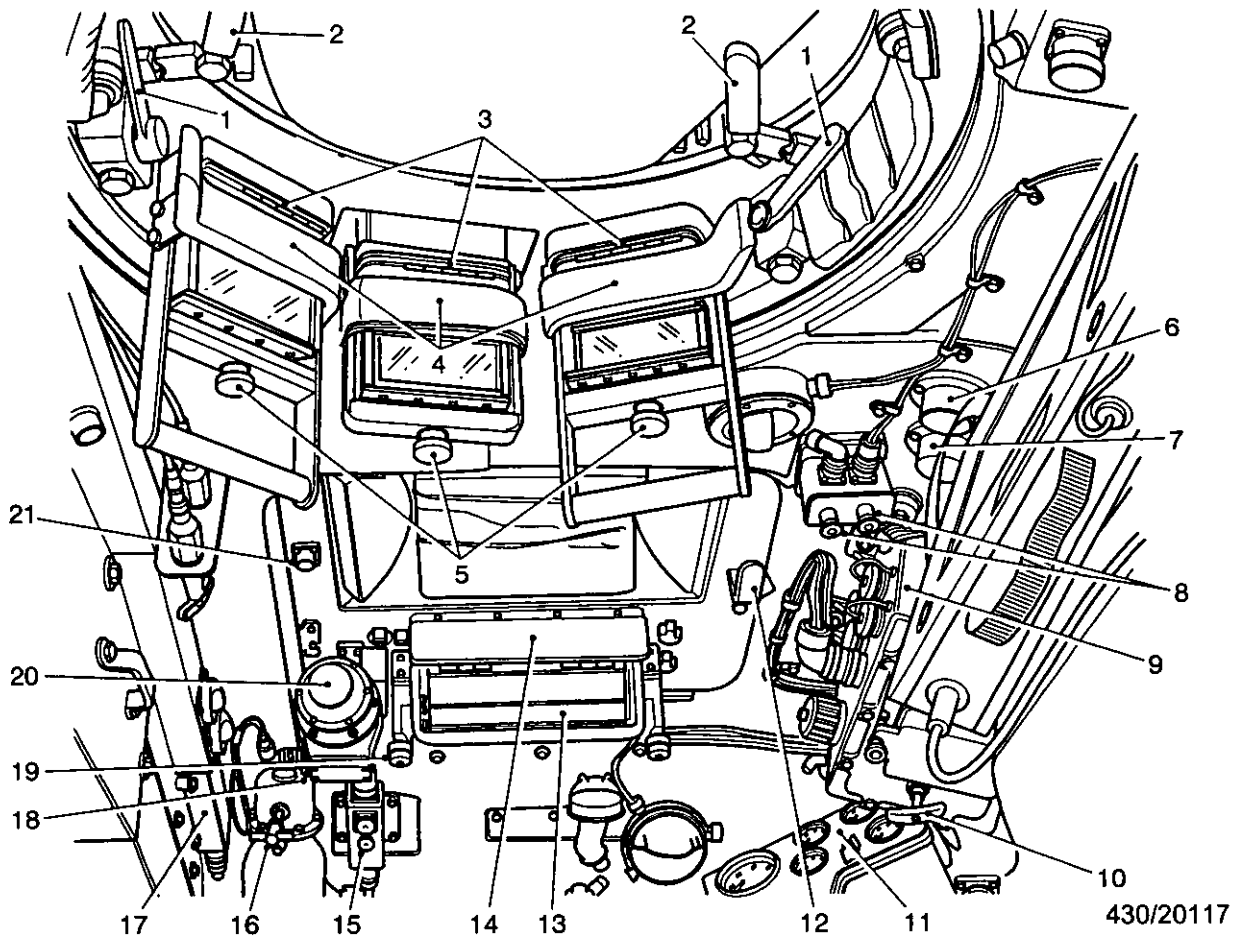

1	Clamp handles	12	Locking catch
2	Cupola door catches	13	Driver's periscope
3	Periscope casing locking catch	14	Brow pad
4	Brow pad	15	Wiper
5	Knurled screws	16	Screen washer control handle
6	Radio battery flame trap	17	Filter unit
7	Automotive battery flame trap	18	Wiper manual control handle
8	Smoke discharger switches	19	Knurled nut
9	Distribution box No. 6 Mk 1	20	Wiper motor
10	Battery Master Switch	21	Dummy socket
11	Instrument panel		

Fig 12 Cupola and driver's hatch (closed)

**Commander's seat**

46 The seat (Fig 13) is attached to the vehicle side plate below the cupola. It is adjustable for height and can be stowed to allow free passage to and from the driver's compartment.

47 To adjust the seat for height, slacken the hand wheel (4) on the seat support (3) lift or lower the seat to the required position, then retighten the hand wheel.

48 The seat and backrest (1) can be moved to facilitate access to the driver's compartment from the personnel compartment. To move the seat, lift the backrest and lower it backwards, then lift the seat at the side opposite the hinge (2).

Maintenance

49 User maintenance to the commander's seat is restricted to checking the security of the seat mounting fixtures. Ensuring all sliding surfaces and pivot points are lightly oiled and that all catches, locking levers and operating mechanisms operate correctly

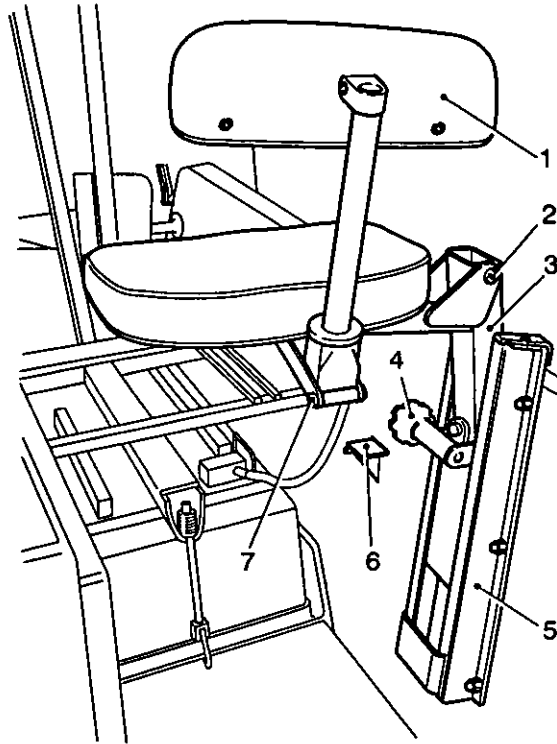

432/046

- 1 Backrest
- 2 Support hinge
- 3 Seat support
- 4 Hand wheel

- 5 Support slide
- 6 Footrest support
- 7 Backrest hinge

Fig 13 Commander's seat

**Commander's instruments and controls**

Vacuum/pressure gauge, air conditioning system

50 The vacuum/pressure gauge, air conditioning system (Fig 14(11) is mounted on the partition plate behind the commander's seat. The gauge reads the internal air pressure when the environmental control system is operating.

Test button, Ventilation system

51 The test button, for the ventilation system (10) is mounted below the vacuum/pressure gauge. When the button is pressed, the vacuum gauge will give an indication of the amount of dust in the environmental control system filters.

Ventilation fan, speed control

52 The ventilation system fan (1), speed control (12) is mounted on the partition plate above the vacuum/pressure gauge.

Auxiliary junction box

53 The auxiliary junction box (Fig 15) is located on the rear of the vertical member forward of the ventilating fan. There are two switches; SWITCH No. 1 at the bottom of the box is redundant and SWITCH No. 2 at the top of the box controls the interior lights.

Smoke discharger switches

54 The smoke discharger switches (Fig 12 (8)) are located to the rear of the driver's hatch. They are of the push button type and fire respectively the right and left smoke dischargers.

Radio distribution box (Mk 2 and Mk 2/1 vehicles)

55 The radio distribution box (Fig 14(2)) is mounted on the RH sill immediately below the ventilating fan motor. The box contains a radio battery switch (4), external charging switch (5) and generator warning light (6).

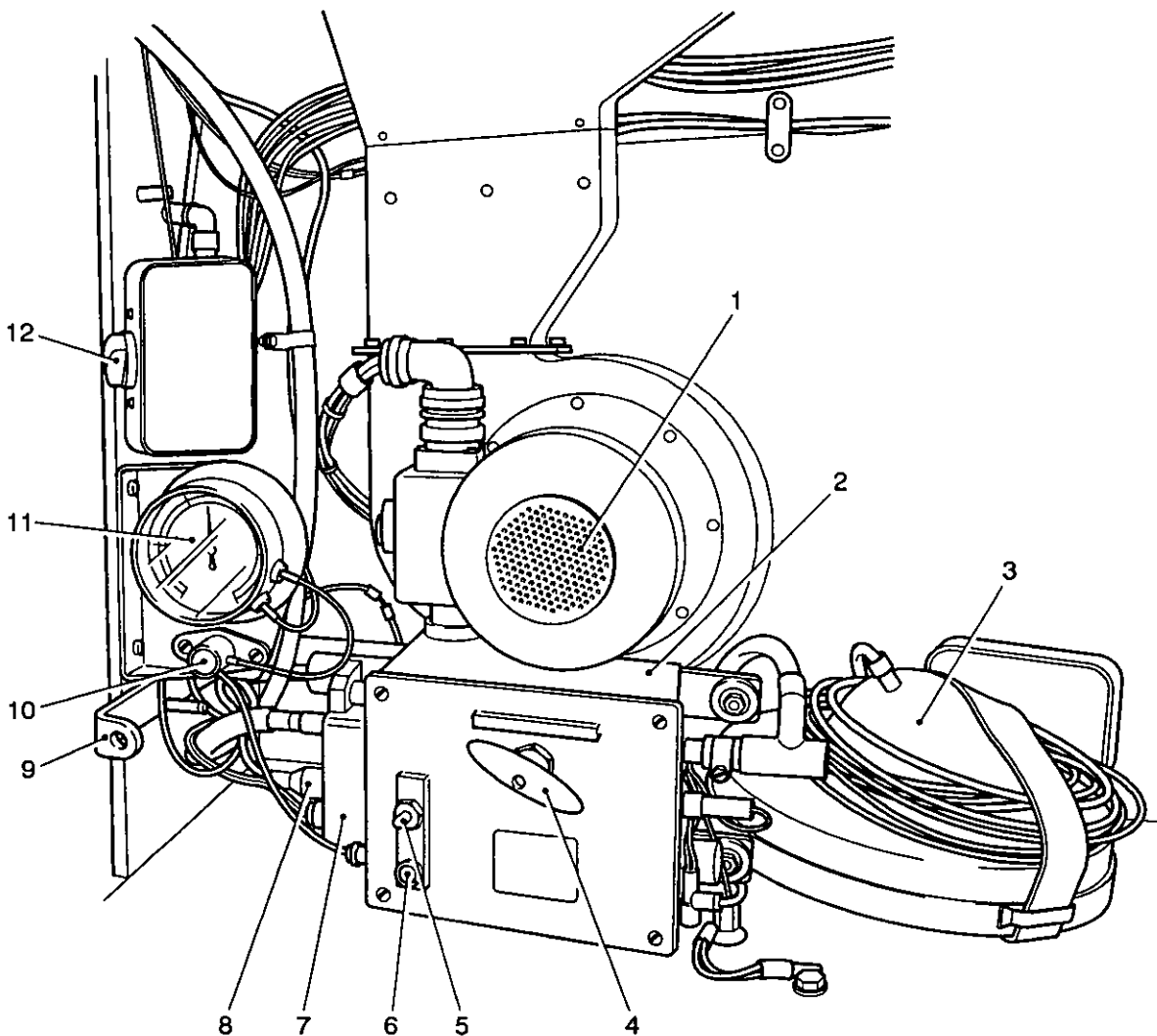

430/20120

- |   |                        |    |                       |
|---|------------------------|----|-----------------------|
| 1 | Fan motor              | 7  | Fuse cover and fuse   |
| 2 | Radio distribution box | 8  | External link         |
| 3 | Spotlight              | 9  | Stowage bar bracket   |
| 4 | Battery switch         | 10 | Test button           |
| 5 | External charge switch | 11 | Pressure/vacuum gauge |
| 6 | GEN warning light      | 12 | Fan control           |

Fig 14 Radio distribution box (Mk 2 vehicles)

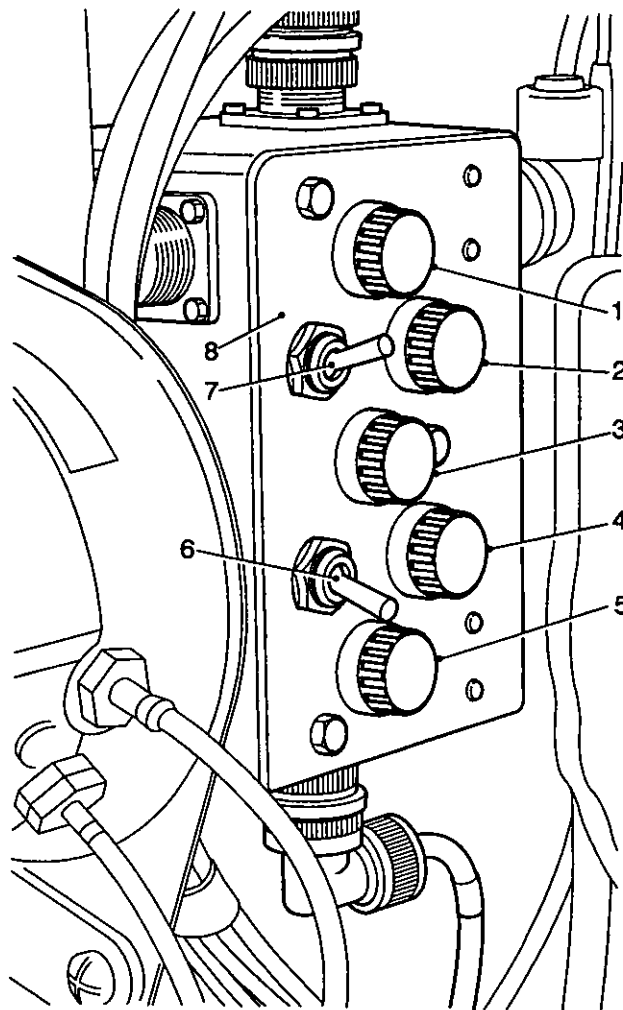

432/091

- |   |         |   |                                |
|---|---------|---|--------------------------------|
| 1 | Fuse F5 | 5 | Fuse F1                        |
| 2 | Fuse F4 | 6 | Switch No. 1 (Redundant)       |
| 3 | Fuse F3 | 7 | Switch No. 2 (Interior lights) |
| 4 | Fuse F2 | 8 | Auxiliary junction box         |

Fig 15 Auxiliary junction box

## PERSONNEL COMPARTMENT

### Personnel seats

#### WARNING

**EQUIPMENT DAMAGE.** Do not stand on the forward left seat when the ventilation batteries have been turned or removed as the seat could collapse.

56 The three double seats (Fig 16(2) and (3)) along each side of the personnel compartment. In the raised position, the seats are held by a double link, which moves over centre against the side plate. The forward seat on the left has shortened support brackets as it is directly above the ventilation batteries when the batteries are in the carrier role position.



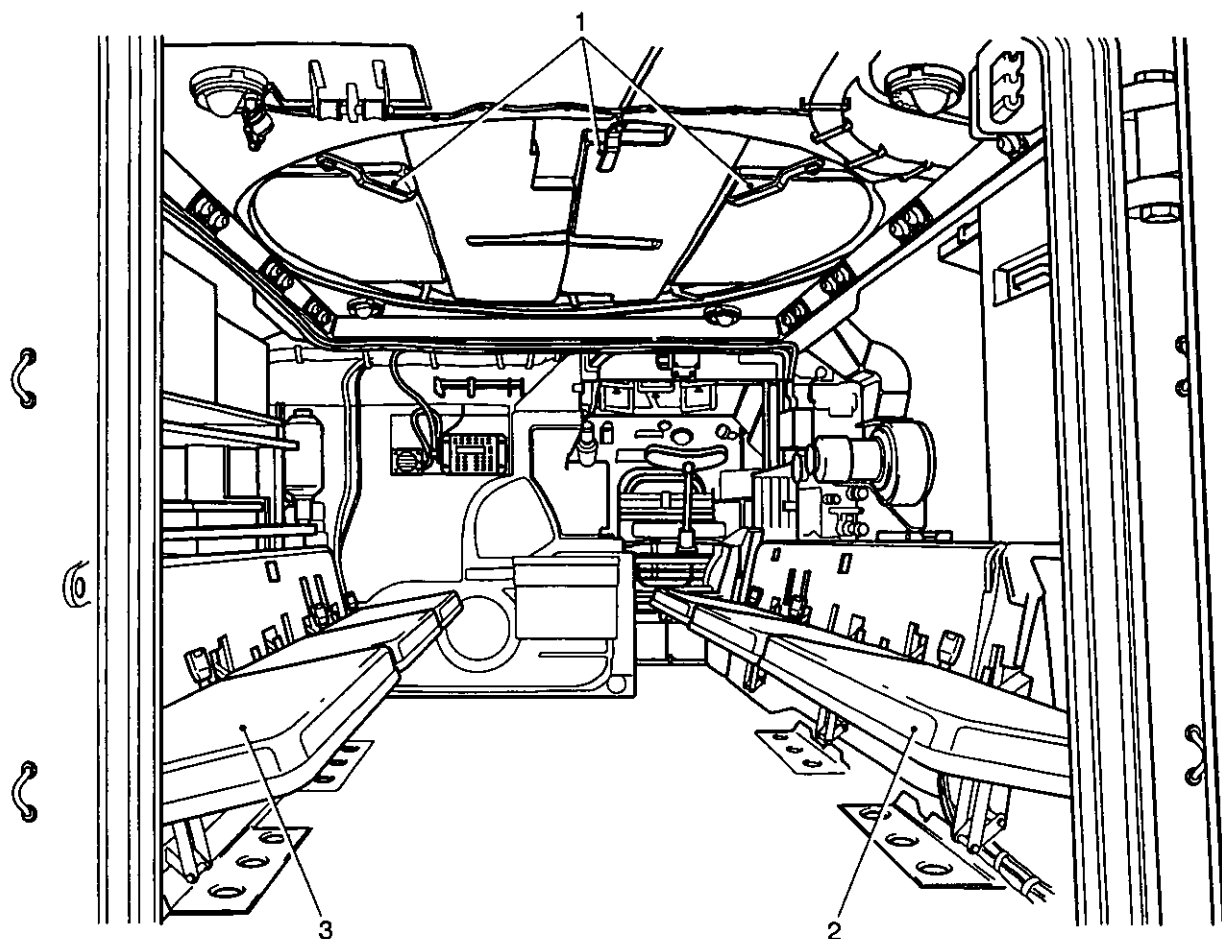

430/20121

- |   |                                |   |                       |
|---|--------------------------------|---|-----------------------|
| 1 | Mortar hatch rotatable catches | 3 | Left, personnel seats |
| 2 | Right, personnel seats         |   |                       |

Fig 16 Interior of vehicle from rear (Mk 2 vehicles)

### Maintenance

57 User maintenance for the personnel seats is restricted to checking the security of the seat mounting fixtures, ensuring the locking catch mechanisms operate to retain the seats in the vertical and horizontal positions, and all hinges and locking catches are lightly oiled.

### **Rear Door**

58 The rear door is hinged and can be secured in the closed position by a locking catch operated by handles inside (Fig 17(3)) and outside (Fig 18(5)) the vehicle. An observation window (Fig 17(2)) is let into the top left corner of the door, with a spring-loaded shutter fitted to the inner side. A hasp (Fig 20(6)) is fitted to provide means of padlocking the door.

59 To ensure the door is sealed effectively, five rotatable clamping catches (Fig 17(1)) are positioned round the inside of the door.

60 The door can be held in the open position by a strut (4) on the door engaged in a staple on the hull rear plate.

61 Two portable fire extinguishers (Fig 18(1)), a convoy light (4) and a registration plate light (2) are attached to the outside of the door.

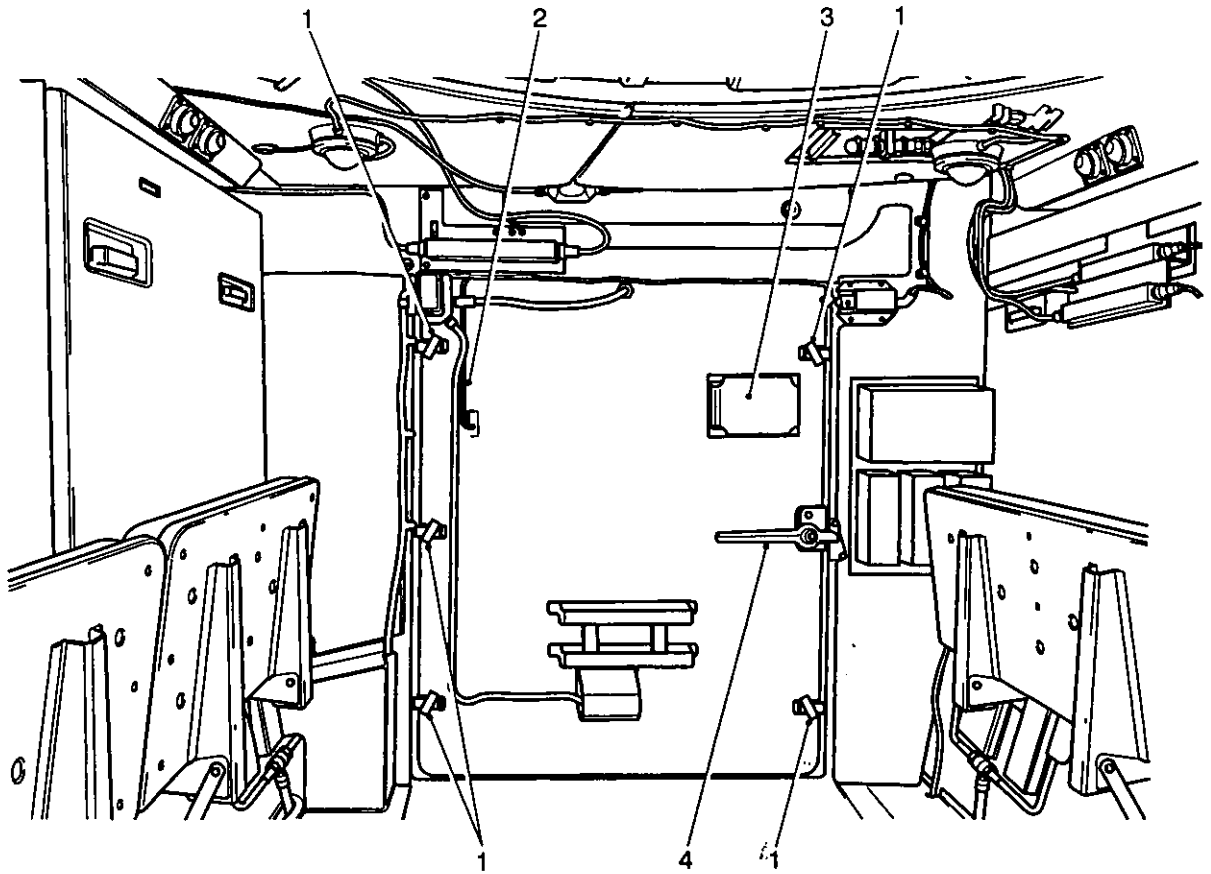

430/20096

- 1 Rear door clamping catches
- 2 Rear door strut

- 3 Observation window
- 4 Door handle

Fig 17 Interior of vehicle from driver's compartment

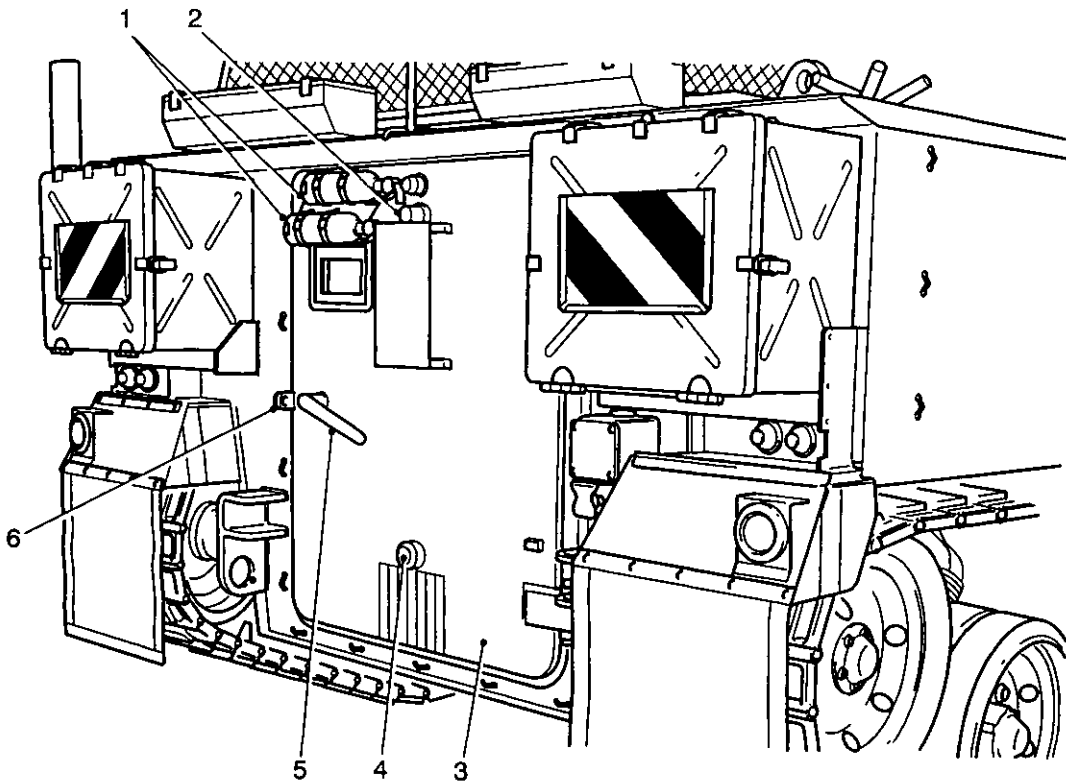

430/20017

- |   |                             |   |               |
|---|-----------------------------|---|---------------|
| 1 | Portable fire extinguishers | 4 | Convoy light  |
| 2 | Registration plate light    | 5 | Door handle   |
| 3 | Rear door                   | 6 | Padlock hasps |

Fig 18 Rear of vehicle

**Mortar Hatch**

62 The mortar hatch (Fig 19) is the large circular hatch over the personnel compartment. When open, the four segments fold back clear of the hatchway. The weight of the segments is counterbalanced by torsion bars. The hatch is secured when closed by six rotatable catches (Fig 16(1)), two on each outer segment and two on the inner segment which overlaps and holds the other inner segment.

Opening the hatch**WARNING**

**PERSONAL INJURY. IF ROOF MOUNTED, EQUIPMENT RESTRICTS THE FULL OR PARTIAL OPENING OF THE MORTAR HATCH ONLY FOUR (4) PERSONNEL ARE TO BE CARRIED IN THE REAR OF THE VEHICLE.**

**CAUTION**

**EQUIPMENT DAMAGE. If the roof basket is fitted, only the right hand mortar hatch can be opened. The roof basket must be removed before the left hand mortar hatch can be opened.**

63 Release the two catches holding the inner segment, raise and fold back the segment until held by the catch (Fig 19(3)) on the outer segment, release the catches holding the outer segment then raise and fold back both segments until held by catch (2) on the roof plate. Open the other half of the hatch similarly but only if the roof basket has been removed (AESP 2350-T-251-412 Inst Instr No 1 refers).

Closing the hatch

64 Release hatch retaining catches (Fig 19(2)) with release hook which is clipped on the roof plate to the rear of mortar hatch, stow hook in clip after use, unfold the segments in the reverse sequence to folding, then secure with the six catches.

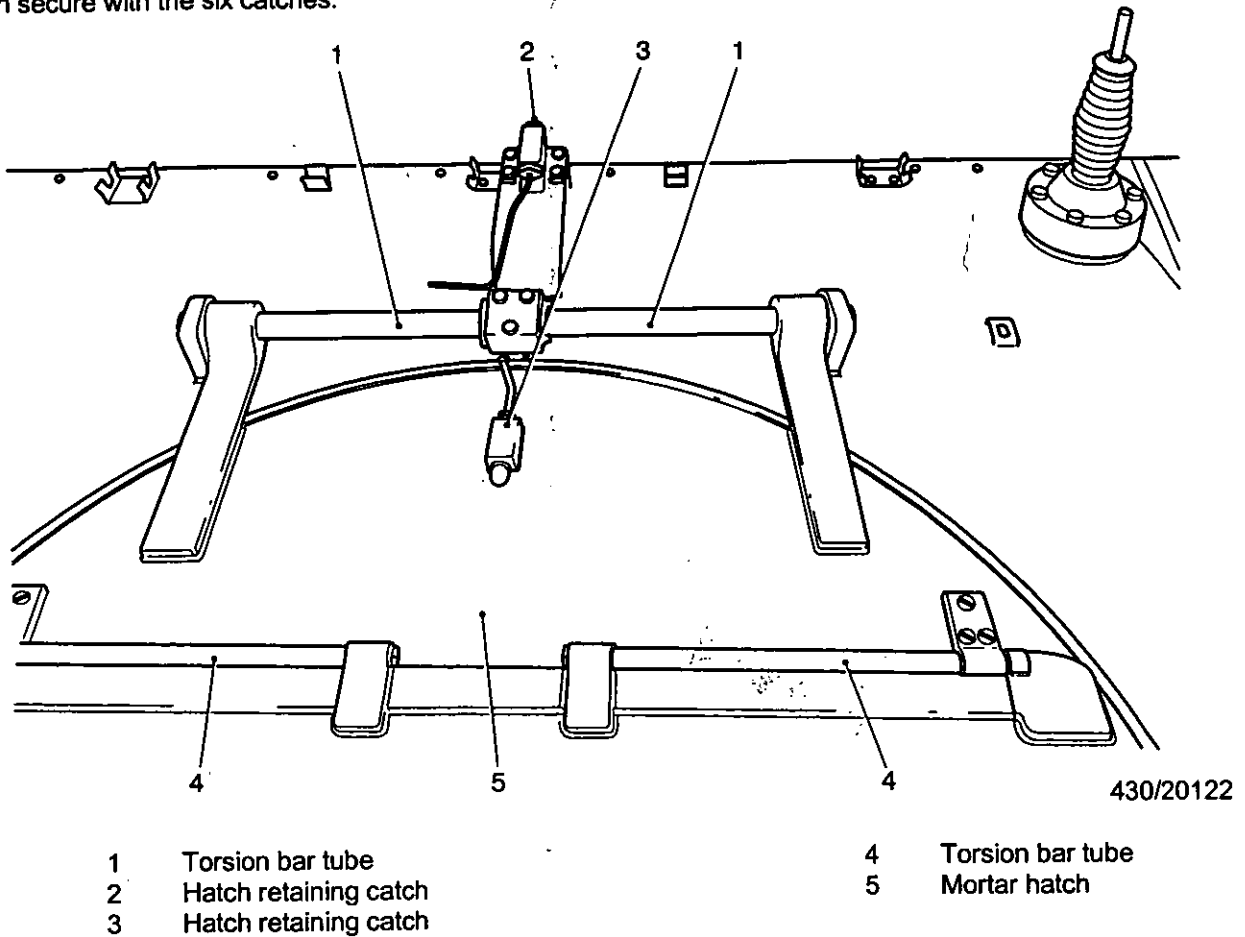

Fig 19 Mortar hatch external view

**Interior lights blackout switch**

65 The interior lights blackout switch is located at the top left corner of the rear door on the inner side. It is provided for use when blackout conditions are in force.

**Fire alarm warning light**

66 The fire alarm warning light is centrally mounted at the top front of the personnel compartment.

**COMMUNICATION EQUIPMENT**

67 Figure 20 is a schematic diagram of the communication equipment installed in the vehicle, it details the equipment fitted in the commander's and driver's stations, crew compartment and loading bay, and is included for reference only. Full details of the operation of the equipment is detailed in the relevant Interactive Electronic Technical Publication (IETP) (TBA) Bowman radio publications.

**NOTE**

This illustration represents a full communications fit, for certain roles some of the equipment may have been removed.

~~UNRESTRICTED~~



REDACTED.

Fig 20 Communication equipment



430/20173

~~UNRESTRICTED~~

**POWER PACK ACCESS**

68 Access to the power pack is either from inside the driver's compartment (Para 38) or via the air inlet and outlet louvres (Fig 1(6)). Access to the steering unit is via the steering unit access cover (7) situated on the hull front plate.

**Air inlet and outlet louvres**

69 The louvres (Fig 21(3) and (7)) are hinged together by torsion bars (2) and secured in the closed position by thirteen turncatches (1) and (9) and two clamp plates (6).

70 The weight of the doors is counterbalanced by the torsion bars and only one louvre can be opened at a time.

71 To open a louvre, release the two clamp plates, then slacken the locknuts and rotate the turncatches a quarter turn. Raise the louvre until over centre then insert the locking pin housed in the bracket (10) through the two holes (8) in the left hinge as they come into alignment.

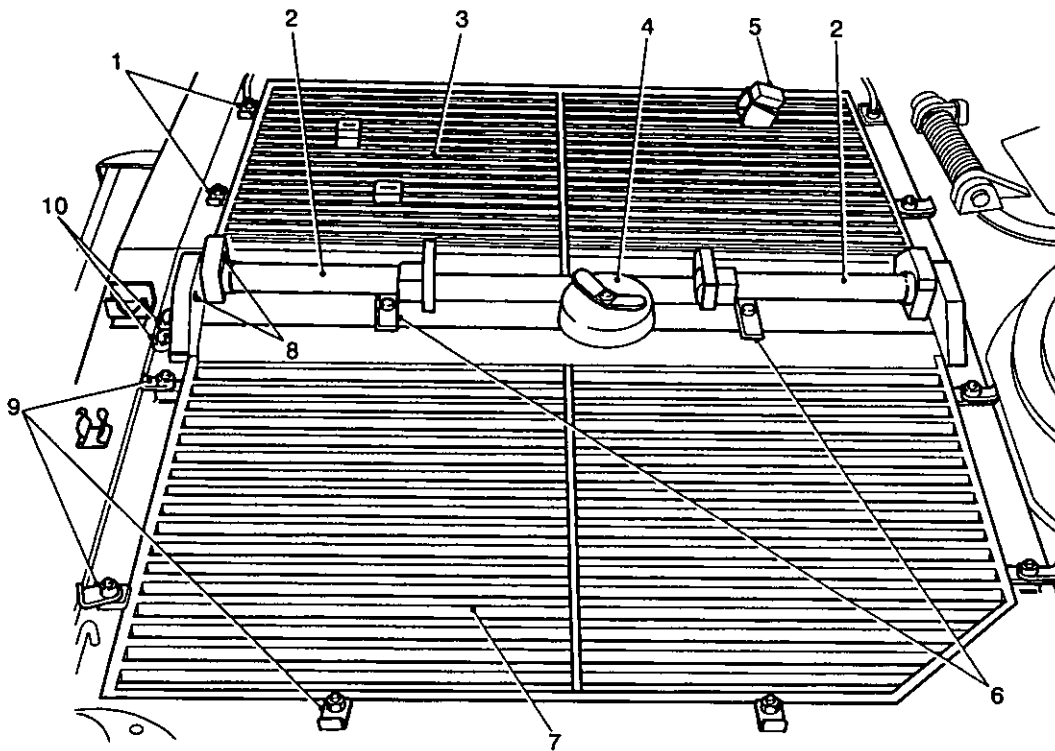

432/059

- |   |                      |    |                             |
|---|----------------------|----|-----------------------------|
| 1 | Turn catch (open)    | 6  | Clamp plates                |
| 2 | Torsion bar tube     | 7  | Outlet louvre               |
| 3 | Inlet louvre         | 8  | Locking pin holes           |
| 4 | Coolant filler cover | 9  | Turn catch (closed)         |
| 5 | Driver's hatch stop  | 10 | Locking pin stowage bracket |

Fig 21 Power pack covers

**Steering unit access cover****WARNING**

**HEAVY WEIGHT. USE EXTREME CAUTION AND ENSURE THAT THE CURRENT REGULATIONS GOVERNING THE LIFTING AND LOWERING OF HEAVY WEIGHTS ARE OBSERVED WHENEVER A STEERING UNIT ACCESS COVER IS OPENED OR CLOSED.**

72 The access cover (Fig 1(7)) is secured by six turncatches, which are released when the locknuts are slackened and the turncatches rotated a quarter turn. Stops welded to the plate, limit the movement of each catch. Two handles are provided for lifting the cover, which hinges at the bottom.

**SMOKE GRENADE DISCHARGERS**

73 The two triple barrelled dischargers (Fig 1(5 and 8)) can be fired independently or both fired together by means of two push buttons (Fig 12(8)) adjacent to the commander.

**To load****WARNINGS**

**(1) PERSONNEL DANGER. FATAL OR SERIOUS INJURY CAN OCCUR IF A SMOKE GRENADE DISCHARGES DURING THE LOADING PROCEDURE. ENSURE THE SMOKE DISCHARGER SWITCH IS IN THE OFF POSITION AND THAT ALL NON-ESSENTIAL PERSONNEL ARE CLEAR OF THE AREA TO A DISTANCE OF 200 METRES.**

**(2) SAFETY HAZARD. RADIO TRANSMISSION, DURING THE LOADING PROCEDURE, CAN CAUSE SMOKE GRENADES TO DISCHARGE. ENSURE NO TRANSMISSION TAKES PLACE DURING THE LOADING PROCEDURE.**

**(3) PERSONAL INJURY. KEEP OUT OF THE LINE OF FIRE OF DISCHARGER BARRELS WHEN LOADING OR UNLOADING SMOKE GRENADES.**

74 Insert the grenade in the barrel, clip end first, then press home to ensure correct engagement of the firing pin and clip.

**To fire**

75 Press the appropriate button on the firing button box.

**Misfire**

76 In the event of a misfire in any barrel, wait 5 minutes then without placing any body part in front unload and throw the grenade clear of the vehicle, or dispose of in accordance with Unit Standing Orders.

**To unload****WARNINGS**

**(1) PERSONNEL DANGER. FATAL OR SERIOUS INJURY CAN OCCUR IF A SMOKE GRENADE DISCHARGES DURING THE UNLOADING PROCEDURE. ENSURE THE ARMING SWITCH IS IN THE OFF POSITION AND THAT ALL NON-ESSENTIAL PERSONNEL ARE CLEAR OF THE AREA TO A DISTANCE OF 200 METRES.**

**(2) SAFETY HAZARD. RADIO TRANSMISSION, DURING THE UNLOADING PROCEDURE, CAN CAUSE SMOKE GRENADES TO DISCHARGE. ENSURE NO TRANSMISSION TAKES PLACE DURING THE UNLOADING PROCEDURE.**

**(3) PERSONAL INJURY. KEEP OUT OF THE LINE OF FIRE OF DISCHARGER BARRELS WHEN LOADING OR UNLOADING SMOKE GRENADES.**

77 Withdraw the grenade from the barrel and place it in a storage canister.

78 Replace the discharger cover.

#### After firing

79 Remove the aluminium sealing plate left in the barrel after firing the grenade and dry clean the barrel.

### HIGH VISIBILITY MARKER BOARDS

80 High visibility boards (Fig 23(2)) are retained in holders (3), which are mounted to each rear stowage bin. The marker boards are reversible; they are painted on the reverse side with the appropriate colour and are then rotated to show the red/yellow side when travelling on public roads.

81 To reverse the high visibility marker boards depress the thumb catch and slide the holder. Fitting is the reverse, with the catch being depressed to avoid damage to board surface. When the chevrons are to be visible then ensure that the marker boards (2) are fitted as shown in Figure 23.

### FUEL SYSTEM

#### WARNINGS

**(1) FIRE HAZARD. A RISK OF FIRE AND/OR EXPLOSION EXISTS WHEN FUEL IS BEING TRANSFERRED FROM ONE CONTAINER TO ANOTHER AT A POINT IN CLOSE PROXIMITY TO A RADAR SET. DO NOT TRANSFER FUEL WHEN A RADAR SET IS IN OPERATION. SAFE DISTANCE WILL VARY FROM 2 TO 275 METRES DEPENDING UPON RADAR EQUIPMENT.**

**(2) FIRE HAZARD. A RISK OF FIRE AND/OR EXPLOSION EXISTS WHEN FUEL IS BEING TRANSFERRED FROM ONE CONTAINER TO ANOTHER AT A POINT IN CLOSE PROXIMITY TO HF RADIO TRANSMISSION. REFUELING SHOULD NOT TAKE PLACE WHILST TRANSMITTING OR IF IN CLOSE PROXIMITY TO ANOTHER VEHICLE, WHICH IS TRANSMITTING.**

**(3) PERSONAL INJURY. THE NO SMOKING OR NAKED LIGHT REGULATIONS MUST BE FOLLOWED WHENEVER FUEL IS BEING TRANSFERRED OR WHEN ANY PART OF THE FUEL SYSTEM IS OPEN.**

82 The fuel system is shown diagrammatically in (Fig 22). The fuel tanks (3, 9) are mounted in the rear of the vehicle, one on either side above the track guard. The tanks feed via a fuel cock (2) into a collector tank (11) under the vehicle floor from where the fuel is drawn by an electric pump (12) which delivers the fuel through a filter (8) to the fuel injector pump (FIP) (6). A pipe from the top of each tank is connected to a vent valve (1) mounted on the roof plate.

#### Fuel tanks

83 The fuel tanks (Fig 22(3 and 9)) are mounted in the rear of the vehicle, one on either side above the track guard. The tanks feed via a fuel cock (2) into a collector tank (11).

84 A fuel sender unit is located in the RH tank, and the gauge shows the total quantity of both tanks. Excess fuel from the FIP is returned (10) to the LH tank. The tanks are vented through a common vent valve on the roof plate. It allows fumes to vent to atmosphere or air to replace used fuel, but prevents fuel spillage if the vehicle tips to one side.

85 The filler caps are located beneath padlocked, hinged covers (Fig 23(1)). To open the covers, remove the padlock and release the catch by pulling the ring attached to the plunger. Report immediately any signs of distortion or defects, which might impair the air seal. This is essential to prevent overheating power pack components.



Filling the fuel tanks

86 The procedure for filling the fuel tanks is as follows:

86.1 With the vehicle standing on level ground and earthed, open the hinged cover (Fig 23(1)) over each tank filler. Ensure the area round the fillers is clean.

86.2 Unscrew and lift out the filler caps.

86.3 Fill both tanks to capacity, checking progress by the fuel gauge reading.

86.4 Replace and secure the filler caps. Close and padlock the hinged covers.

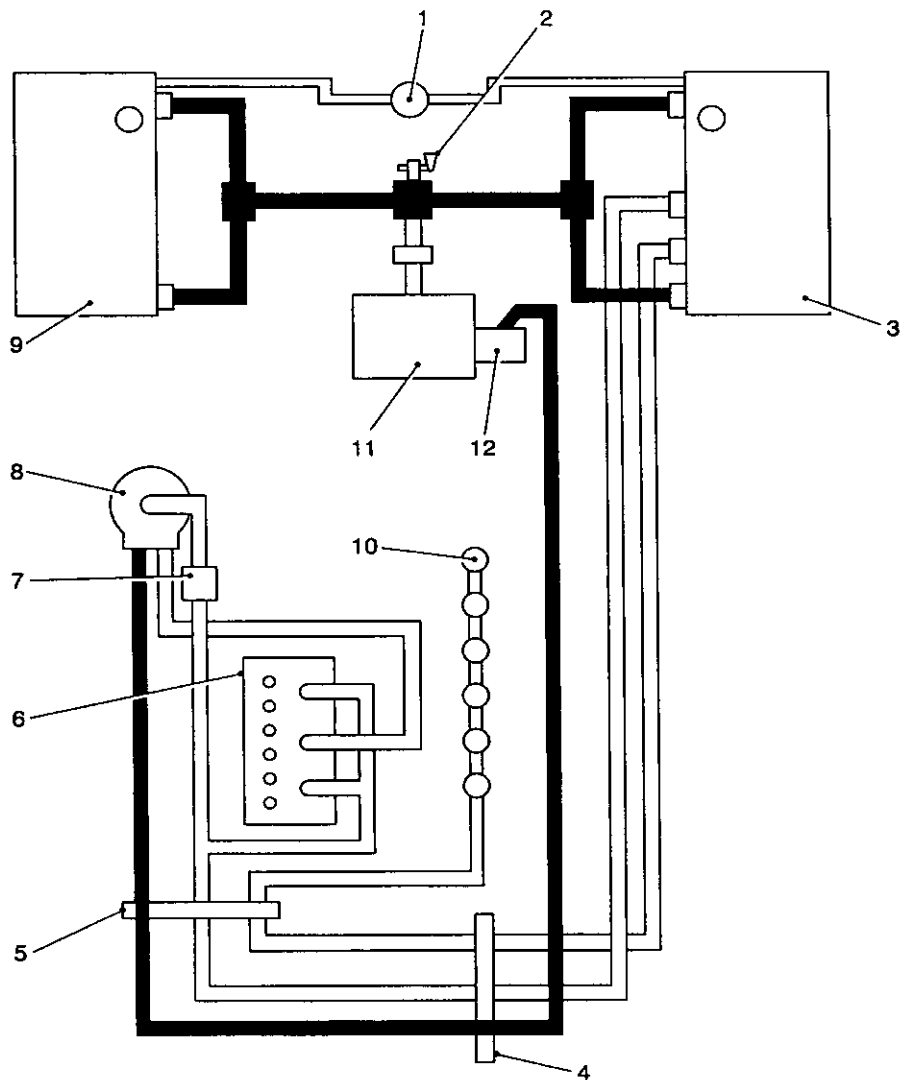

432/482

1	Vent	7	Non return valve
2	Fuel cock	8	Fuel filter
3	LH Fuel tank	9	RH fuel tank
4	Hull junction	10	Fuel return
5	Power pack junction (PPJ)	11	Collector tank
6	Fuel injection pump	12	Electric Pump

Fig 22 Fuel system schematic

Draining the fuel tanks

87 The tanks are drained through a valve located centrally under the floor plate at the rear of the personnel compartment. Access to the valve unit is through a hole in the hull bottom plate, after removing a circular plate (Fig 24(5)). The drain valve assembly (Fig 25) has two plugs, one used to regulate the flow of fuel (1), the other to give access to the valve (2). Have suitably sized receptacles ready to collect the draining fuel, drain the fuel tanks as follows:

- 87.1 Earth the vehicle. Check that the fuel cock is open
- 87.2 Unscrew the regulating plug (1), that is, the one with the larger head. This must be done slowly as fuel may gush out when the plug is removed if the valve is not seated correctly.
- 87.3 Remove the drain valve access plug (2).

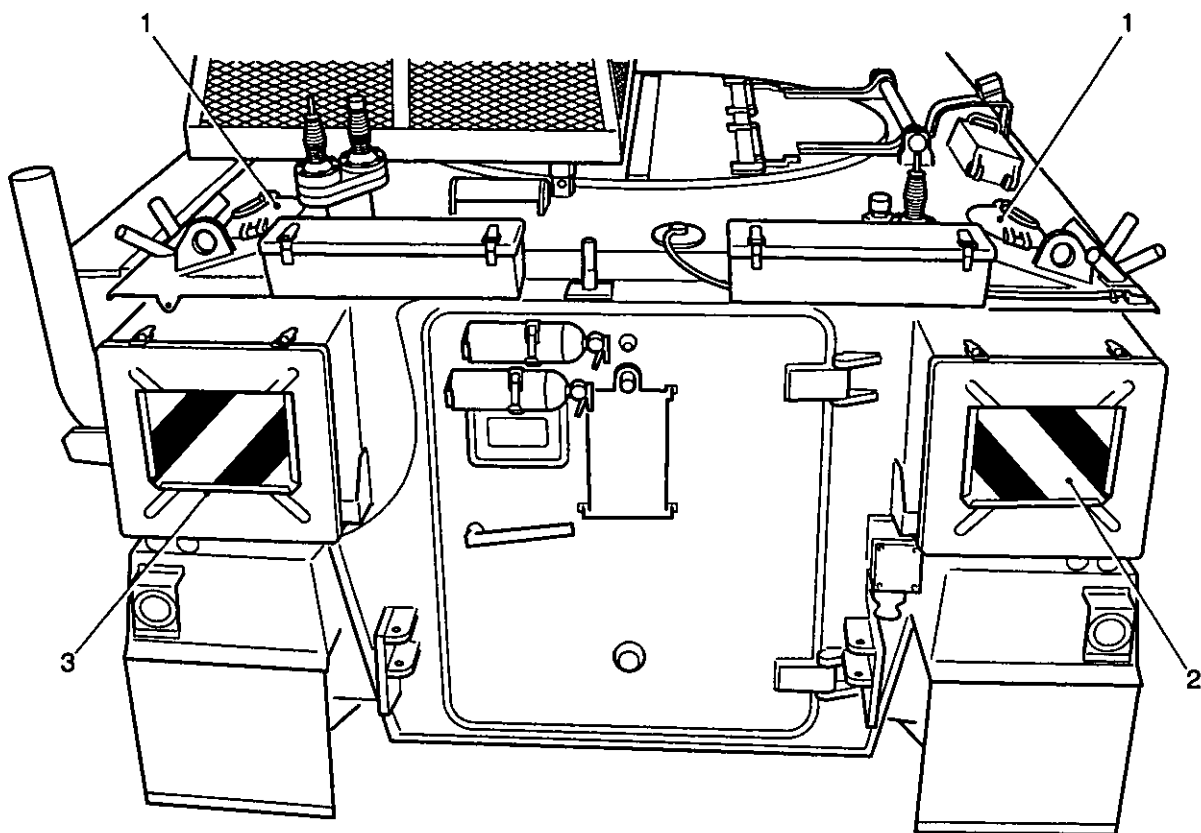

430/20123A

- 1 Fuel filler covers
- 2 Marker board
- 3 Holder

Fig 23 Location of fuel filler cover

87.4 Position a suitably sized receptacle to collect drained fuel, and then screw the regulating plug into the access plughole until fuel starts to drain. Screwing the regulating plug in further increases the flow, unscrewing it decreases and stops the flow.

87.5 Replace the plugs in their original positions, checking the washers for serviceability and correct fitting.

87.6 Replace the access plate and stow the earth spike.

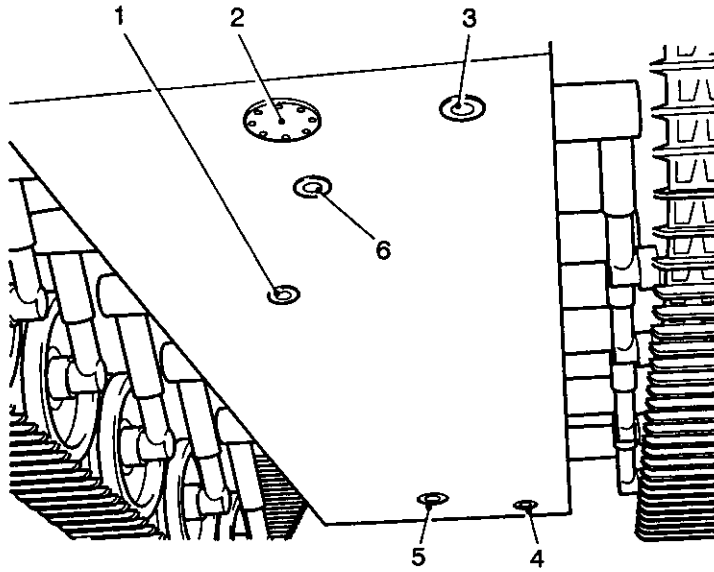

432/052

- |   |  |   |                               |
|---|--|---|-------------------------------|
| 1 | Gearbox drain access plug                            | 4 | Hull drain plug               |
| 2 | Steering unit drain access plate                     | 5 | Fuel drain valve access plate |
| 3 | Steering unit oil tank and coolant drain access plug | 6 | Engine oil drain access plug  |

Fig 24 Hull bottom plate

**Collector Tank**

88 The collector tank (Fig 25(2)) is located beneath the rear section of floor panelling. Fitted to the collector tank is:

- 88.1 An electric pump (1), that delivers fuel through a filter (Fig 22(8)) to the fuel injector pump (6).
- 88.2 A fuel cock (Fig 26(7))
- 88.3 A spill valve (3) is used to drain water from a dropped recess in the bass of the tank.
- 88.4 A drain valve (4) is situated underneath the collector tank (Fig 25).

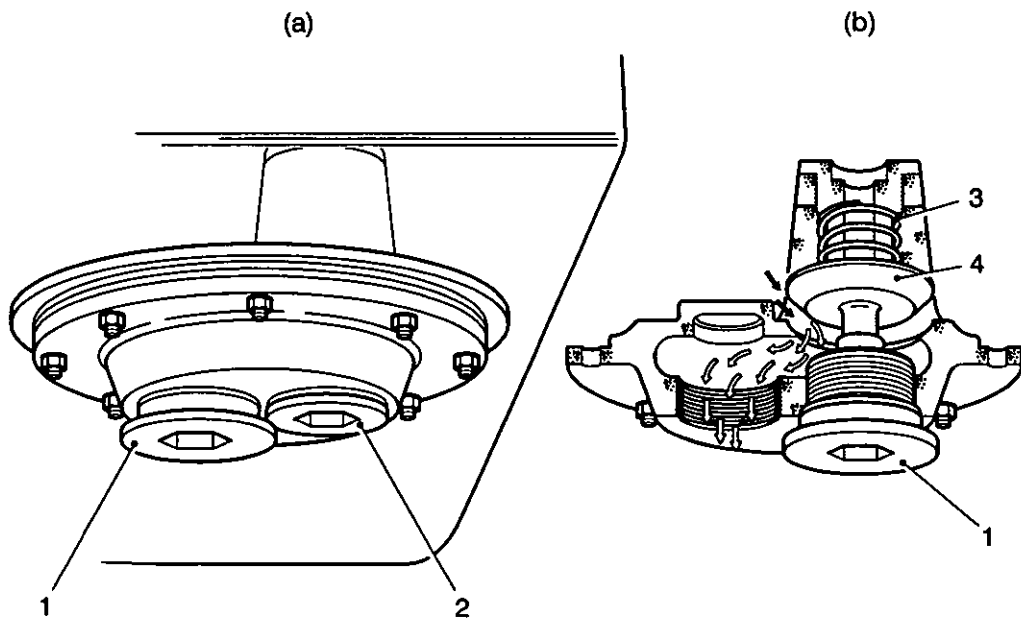

434/020

- |   |                         |     |                                      |
|---|-------------------------|-----|--------------------------------------|
| 1 | Regulating plug         | (a) | Plugs in normal position             |
| 2 | Drain valve access plug | (b) | Regulating plug in draining position |
| 3 | Valve spring            |     |                                      |
| 4 | Valve                   |     |                                      |

Fig 25 Fuel tank drain valve

Draining water from the collector tank

89 The procedure for draining water from the collector tank (Fig 26(2)) is as follows:

- 89.1 Earth the vehicle and remove the rear floor plate, or in the case of the APC or Mortar role vehicles, lift the small access cover provided in the rear floor plate.
- 89.2 Provide a supply of cloth to soak up the water and fuel released.
- 89.3 Switch fuel cock (7) to the OFF position.
- 89.4 Release the locknut (4) and unscrew the valve pin (5).
- 89.5 Drain until only clean fuel is flowing, then close the valve pin and tighten the locknut.
- 89.6 Switch fuel cock to ON position.
- 89.7 Soak up the drained water and fuel and then refit the floor plate or close the access cover.
- 89.8 Stow the earth spike.

**Maintenance**

Checking and topping up the governor oil level

90 The procedure for checking and topping up the governor oil level, is as follows:

- 90.1 Remove the power pack access plate (Para 42 refers).
- 90.2 Clean the area surrounding the dipstick (Fig 27(2)).
- 90.3 Withdraw the dipstick.

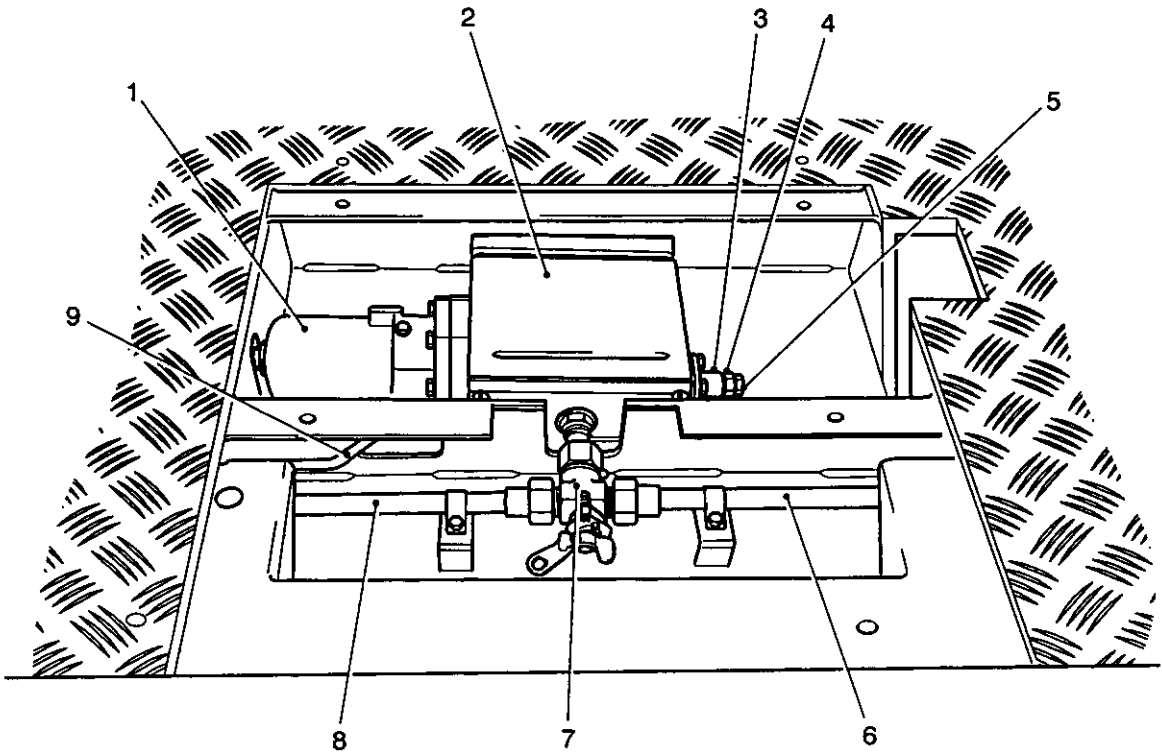

432/053a

1	Fuel pump	6	Fuel pipe from right tank
2	Collector tank	7	Fuel cock
3	Spill valve	8	Fuel pipe from left tank
4	Locknut	9	Fuel pipe to engine
5	Valve pin		

Fig 26 Fuel collector tank

90.4 The level should be up to the full mark on the dipstick. If necessary, top up through the filter/dipstick hole.

90.5 Replace the dipstick.

90.6 Refit the power pack access plate.

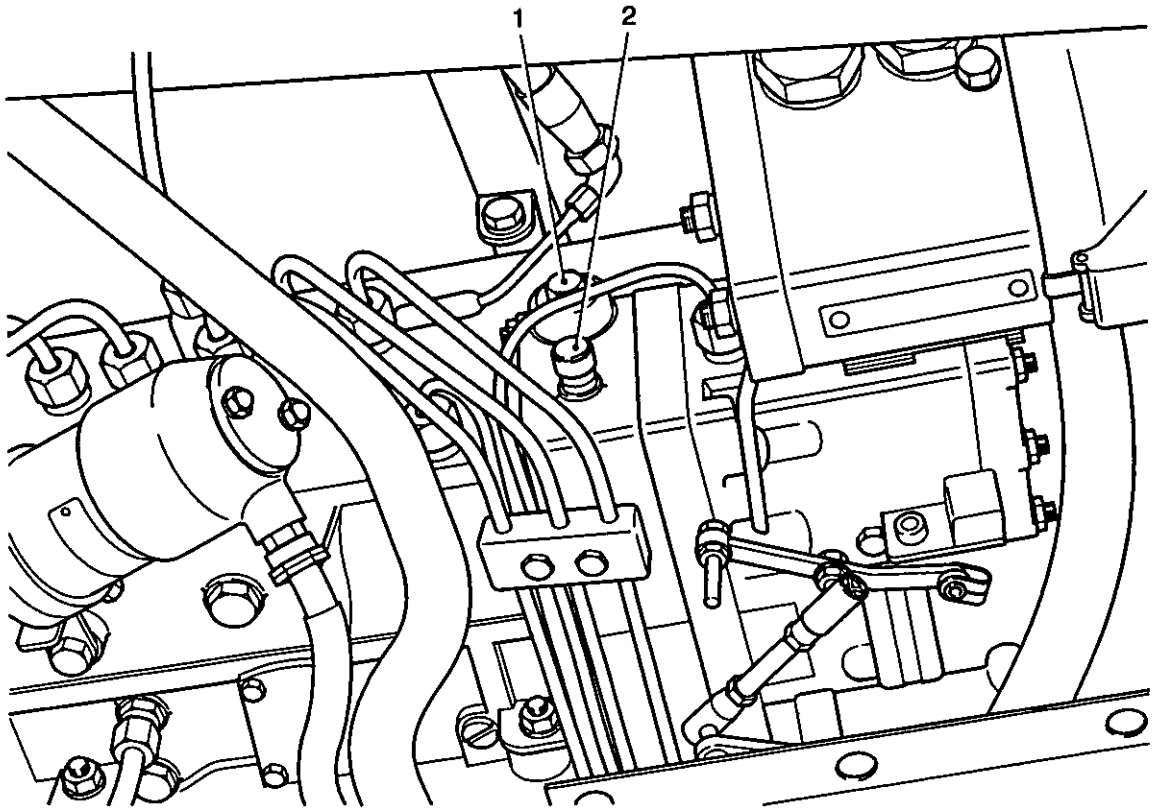

432/058

1 Breather, governor

2 Dipstick, governor

Fig 27 Injection pump governor

## HULL MAINTENANCE

### Draining the vehicle hull

#### WARNING

**ENVIRONMENTAL HAZARD. DO NOT DRAIN THE FLUID CONTENTS OF THE HULL ONTO THE GROUND. SUITABLE CONTAINERS SHOULD BE USED TO COLLECT THE DRAINED FLUIDS**

91 The vehicle hull can be drained by removing the four plugs (Fig 24(1), (3), (4) and (6)) in the hull bottom plate. The bosses into which the plugs screw may be flush with the bottom plate or, if proud, drilled radially to allow drainage. Before replacing, the plugs, check that the radial holes, if present, are clear and the plugs are serviceable.

#### Hull details lubrication

92 Using an oil can sparingly, lubricate the hinges, catches and movable parts of the driver's hatch and seat, commander's cupola and seat, personnel seats, mortar hatch, rear door, track guard hinges and other working parts.

**MOUNT, GUN, 7.62 mm, No 3 Mk 1**

93 The FV430 Series is fitted for use with General Purpose Machine Gun 7.62 mm L7 (GPMG) using machine gun mount No 3 Mk 1.

**REDACTED**

95 To install the mount, withdraw the pintle-securing pin from the socket, insert the mount and replace the pin. Secure the travelling strut (Fig 28(11)).

**CAUTION**

**EQUIPMENT DAMAGE.** To prevent damage to the engine fans, ensure the spent case bin is emptied at the specified intervals

96 During firing operations, it is essential that the spent case bin be emptied before they are completely full and overflowing. Empty cartridge cases and links, which overflow, are liable to enter the engine air louvres and cause damage to the engine fans.

97 The No 3 mount bin should be emptied every 150-200 rounds (3/4-1 belt).

98 The mount consists of a saddle (Fig 28(16)) welded to a pintle, which fits into the socket on the cupola and a gun cradle (10) suspended between the saddle horns by two pivot pins (5), which are secured by circlips.

99 Welded to the left side of the cradle are clamp brackets which secure the rough alignment sights (2) and (14). The sights can be adjusted then locked in position by tightening the setscrews. Mounted on the rear of the saddle is a spent case bin (9) that is hung on two bosses (6) with the lower part resting against a rubber pad (15) bonded to the rear of the saddle.

100 The GPMG is secured to the cradle by two pins (4) and (12) which are locked in position by two catch plates (3). The rear pin projects to the left forming a handle grip.

101 An ejection chute (7) is bolted to the right side of the cradle to receive and deflect the belt links into the spent case bin, and a deflector plate (8) is bolted underneath the cradle for the cartridge cases.

102 The ammunition box carrier (1) is bolted to the left side of the cradle. The ammunition box is held in position by a lug at the top and a spring catch (17) at the bottom of the carrier.

103 The travelling strut (11) is secured by a pivot pin in a bracket welded to the cupola periscope guard. For travelling, the cradle is secured by engaging the strut in the spring clip (13) at the rear of the cradle.

104 A weatherproof cover fastened by press-studs is provided to encase the gun mount.

**Mounting the GPMG**

105 Remove the two securing pins and place the GPMG with the ejection opening cover opened, in the cradle, and slide the GPMG along until the holes are aligned. Insert the securing pins and engage the catch plates.

106 When not in use, position the gun to ensure it does not obstruct the opening of the driver's hatch.

**Removing the GPMG**

107 Release the catch plates and withdraw the securing pins. Remove the GPMG, then replace and secure the pins.

**Securing the GPMG for travelling**

108 Engage the stirrup shaped end of the support in the spring clip at the rear of the cradle.

**Positioning the spent case bin**

109 Depress the GPMG and position the bin with the keyhole shaped slots over the bosses (Fig 28(6)), then lower the bin until it is suspended on the bosses and resting against the rubber pad on the saddle.

**Removing the spent case bin**

110 Depress the GPMG, then lift and withdraw the bin from the mount.

**Servicing and maintenance**

111 Inspect the mount visually to ensure the components are correctly assembled and secure. Lightly lubricate all movable parts and grease the pintle and pintle socket.

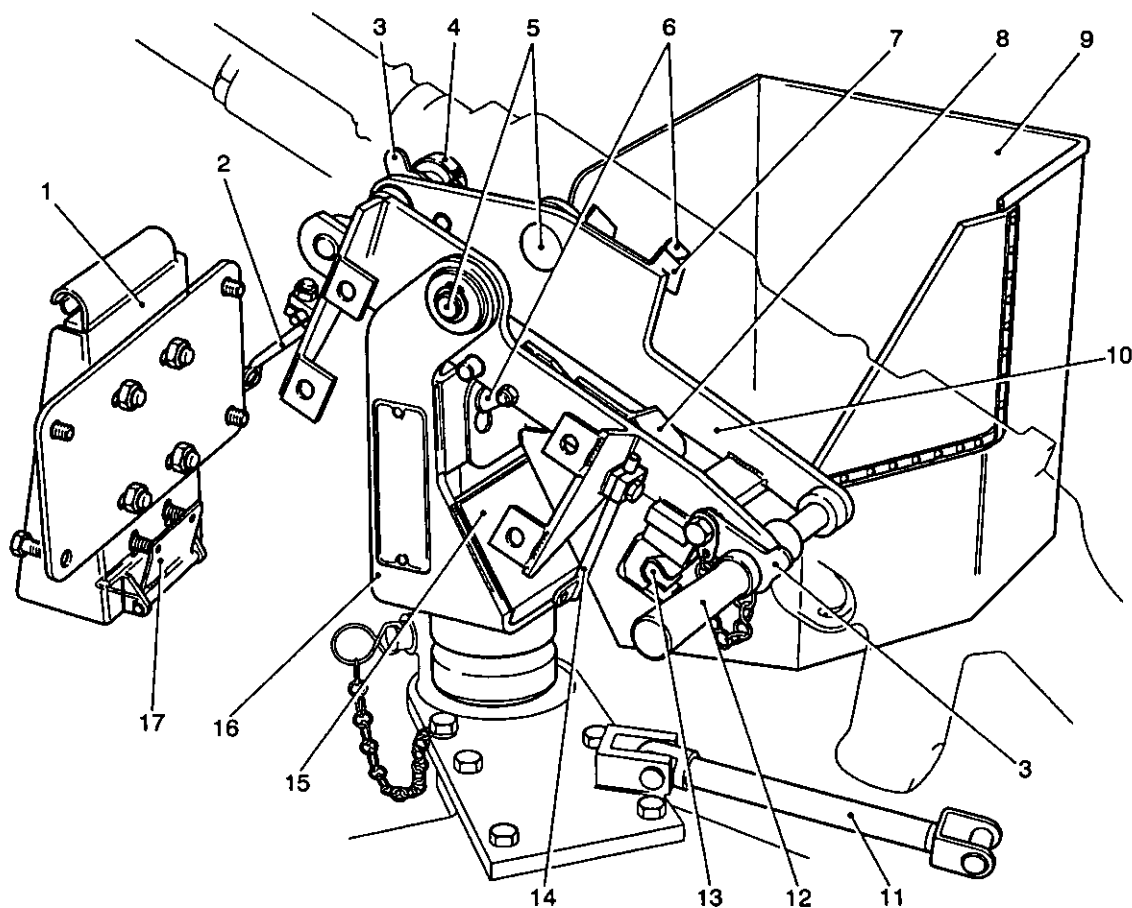

432/131

- |   |                            |    |                   |
|---|----------------------------|----|-------------------|
| 1 | Ammunition carrier         | 10 | Cradle            |
| 2 | Fore sight                 | 11 | Travelling strut  |
| 3 | Catch plate                | 12 | Rear mounting pin |
| 4 | Front mounting pin         | 13 | Spring clip       |
| 5 | Cradle pivot pins          | 14 | Rear sight        |
| 6 | Bosses                     | 15 | Rubber pad        |
| 7 | Belt link ejection tube    | 16 | Saddle            |
| 8 | Spent case deflector plate | 17 | Spring catch      |
| 9 | Spent case bin             |    |                   |

Fig 28 Mount, gun 7.62mm No 3 Mk 1



• **UNRESTRICTED**

• **UNRESTRICTED**

**CHAPTER 2-3**  
**POWER PACK**  
**CONTENTS**

Para

- 1 Introduction
- 4 Engine
  - 5 Accelerator control linkage
  - 6 Crankshaft seals lubrication
  - 7 Checking and topping up the engine oil (WARNING)
  - 8 Changing the engine oil (WARNING)
  - 9 Renewing the oil filter elements
  - 10 Cleaning the engine oil tank breather
- 11 Fuel filter
  - Maintenance
- 12 Cleaning the fuel filter
- 13 Cooling system
  - 18 Checking and topping up the cooling system (WARNINGS)(CAUTION)
  - 19 Draining, flushing, and refilling the cooling system
- 20 Hydraulic fan drive system
  - 22 Checking the hydraulic fan drive tank oil level
  - 23 Draining and refilling the hydraulic system (CAUTION)
  - 24 Cleaning the hydraulic fan drive magnetic filters (CAUTION)
- 25 Air cleaner
  - 29 Changing the air cleaner elements
- Transmission
  - 30 Gearbox
    - 33 Transfer gearbox
    - 34 Checking the gearbox oil level and topping up
    - 36 Changing the gearbox oil (power pack removed)
    - 37 Changing the gearbox oil filter element
    - 38 Changing the gearbox oil (power pack fitted)
    - 39 Gearbox coupling lubrication

Fig

Page

1	Power pack, front right.....	2
2	Power pack, rear left.....	3
3	Steering and accelerator linkage lubricators .....	4
4	Coolant pump and crankshaft seal's lubrication .....	5
5	Power pack, access plate removed.....	5
6	Hull bottom plate.....	7
7	Engine oil filter.....	8
8	Hydraulic fans.....	9
9	Fuel filter.....	10
10	Cooling system.....	11
11	Power pack covers.....	13
12	Power pack, front right.....	14
13	Magnetic filter.....	16
14	Air cleaners and radiators.....	17
15	Driver's compartment.....	19
16	Gearbox oil filter.....	20
17	Radio batteries (Maintenance free).....	21
18	Gearbox coupling.....	22

## INTRODUCTION

1 The power pack (Fig 1) is a complete unit containing all the assemblies required to supply power, both electrical and mechanical, to the vehicle with a gearbox incorporated to give mechanical variation in torque and direction.

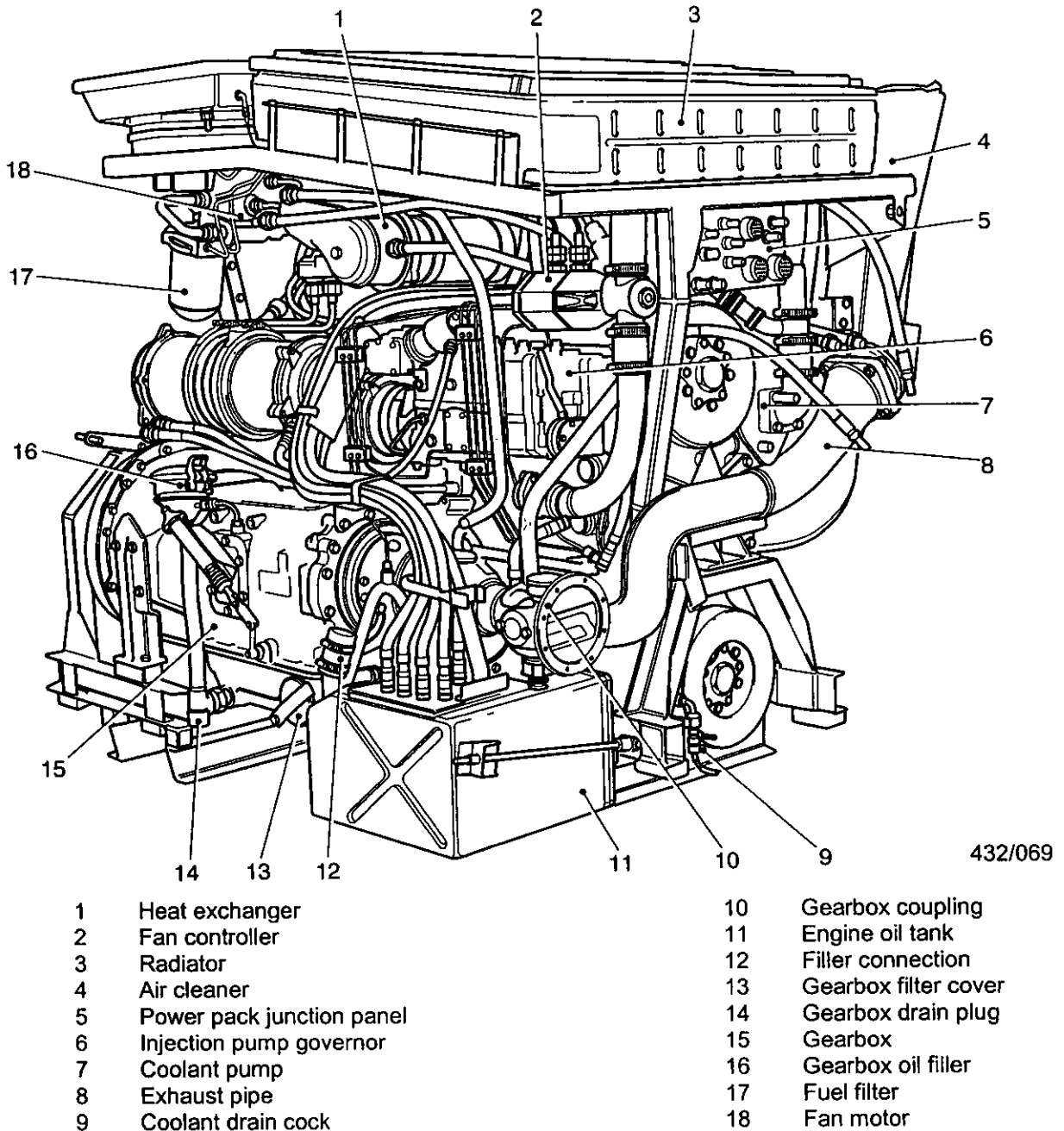

432/069

- |   |                           |    |                      |
|---|---------------------------|----|----------------------|
| 1 | Heat exchanger            | 10 | Gearbox coupling     |
| 2 | Fan controller            | 11 | Engine oil tank      |
| 3 | Radiator                  | 12 | Filter connection    |
| 4 | Air cleaner               | 13 | Gearbox filter cover |
| 5 | Power pack junction panel | 14 | Gearbox drain plug   |
| 6 | Injection pump governor   | 15 | Gearbox              |
| 7 | Coolant pump              | 16 | Gearbox oil filler   |
| 8 | Exhaust pipe              | 17 | Fuel filter          |
| 9 | Coolant drain cock        | 18 | Fan motor            |

Fig 1 Power pack, front right

2 The connections for the electrical circuits, fuel and fire warning system are made at the front of the power pack on the power pack junction (PPJ) (Fig 1 (5)).

3 The power pack is a self-contained unit, which can be removed from, or installed in, the vehicle as a single assembly. It comprises an engine, with its attendant oil tank (11), heat exchanger (1), radiator (3), hydraulic fan assembly and air cleaner (4) with a semi automatic gearbox (GM-Allison TX200-4A) (15) having six forward gears and one reverse gear and a transfer gearbox (Fig 2 (5)).

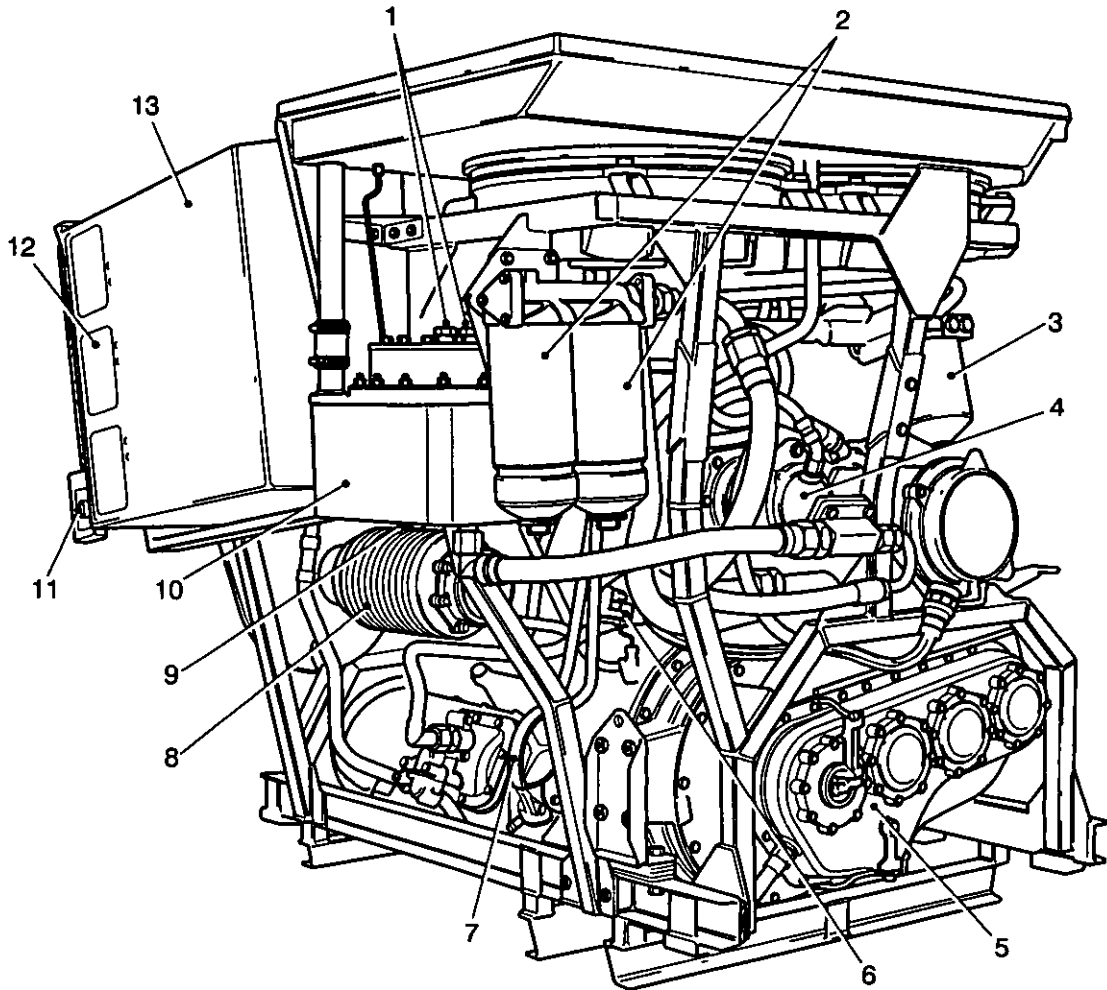

432/066

- |   |                              |    |                           |
|---|------------------------------|----|---------------------------|
| 1 | Magnetic filters             | 8  | Blower                    |
| 2 | Oil filters                  | 9  | Drain plug, oil tank      |
| 3 | Fuel filters                 | 10 | Hydraulic fans oil tank   |
| 4 | Hydraulic fan pump           | 11 | Dust discharge orifice    |
| 5 | Transverse gearbox           | 12 | Air cleaner, first stage  |
| 6 | Tacho-generator              | 13 | Air cleaner, second stage |
| 7 | Starter motor securing strap |    |                           |

Fig 2 Power pack, rear left

## ENGINE

4 The vehicle is powered by a K60 Mk 4F or Mk 6F engine of Rolls Royce design. The engine is a six cylinder, vertically opposed, two-stroke diesel (compression ignition).

### Accelerator control linkage

5 The accelerator cross-shaft bearings are lubricated through the two rear nipples (Fig 3(7)) in a row of five located adjacent to the right steering/brake lever. Lubricate the pivoting parts of the linkage using an oilcan.

### Crankshaft seals lubrication

6 This lubrication can only be undertaken when the power pack is removed from the vehicle. Two grease nipples (Fig 4(2)) are fitted on the left side, front of the engine adjacent to the coolant pump. Lubricate by giving one full pumping stroke of the grease gun.

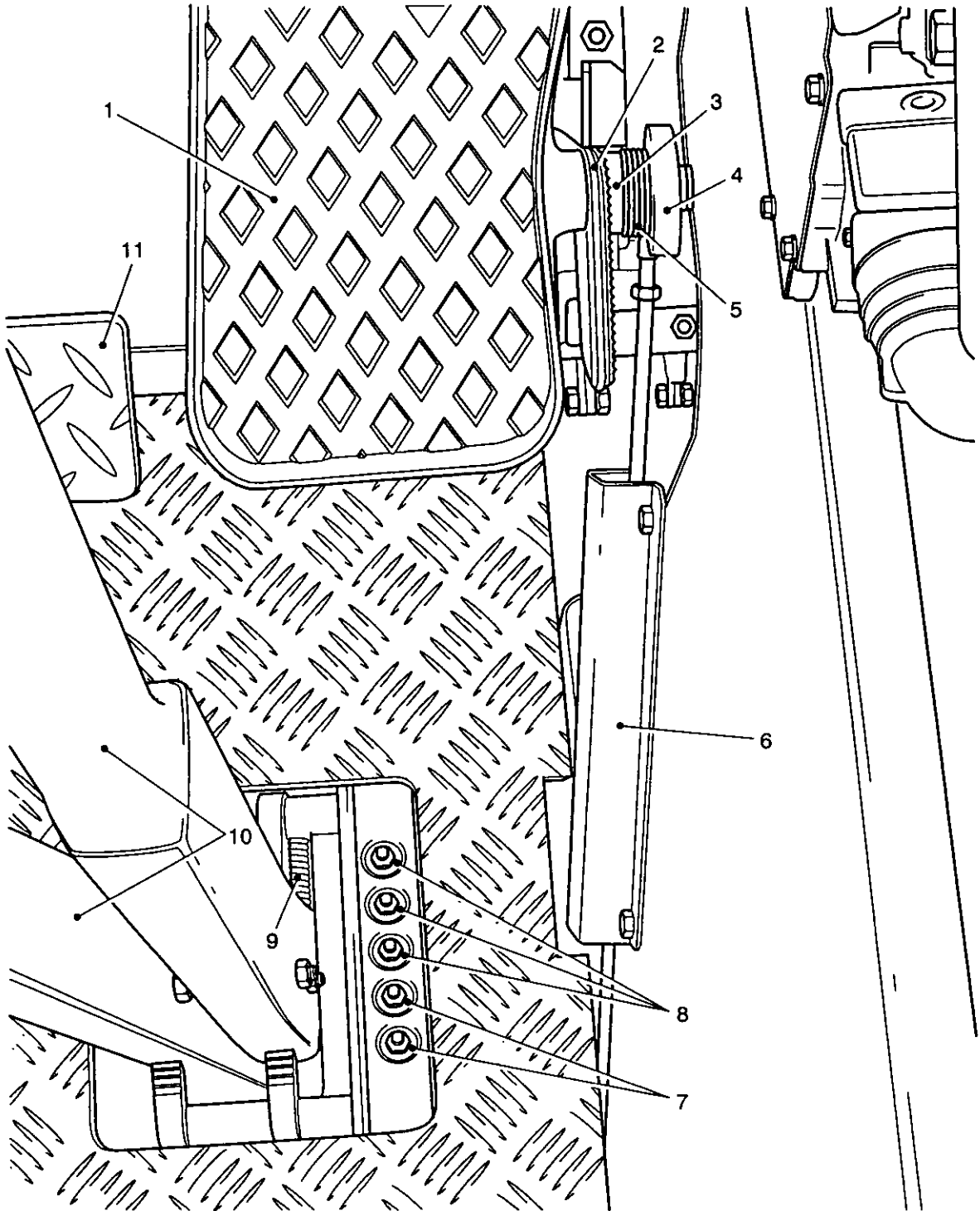

432/061

- |   |                   |    |                                     |
|---|-------------------|----|-------------------------------------|
| 1 | Accelerator pedal | 7  | Accelerator cross-shaft lubricators |
| 2 | Quadrant          | 8  | Steering linkage lubricators        |
| 3 | Toothed washer    | 9  | Steering lever return spring        |
| 4 | Knurled nut       | 10 | Steering/brake levers               |
| 5 | Spring            | 11 | Fuel stop control pedal             |
| 6 | Guard             |    |                                     |

Fig 3 Steering and accelerator linkage lubricators

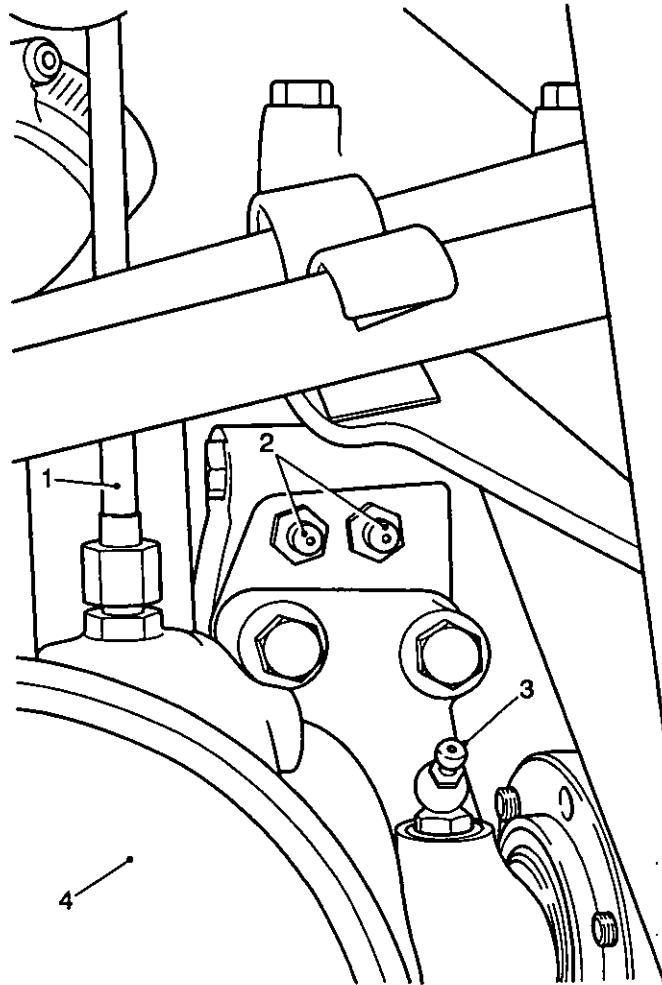

432/060

- |   |                         |   |  |
|---|-------------------------|---|--|
| 1 | Coolant pump vent pipe  | 3 | Coolant pump nipple (not fitted to later vehicles) |
| 2 | Crankshaft seal nipples | 4 | Exhaust  |

Fig 4 Coolant pump and crankshaft seal's lubrication

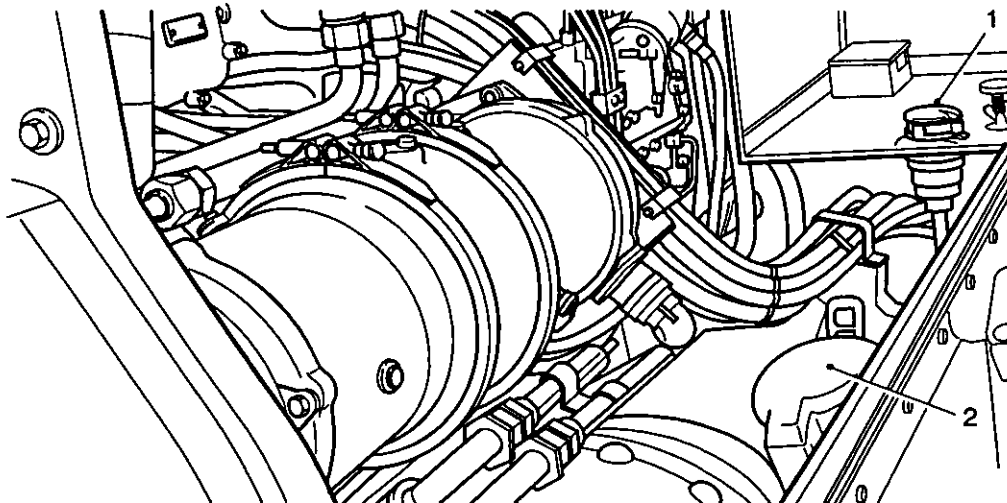

432/056

- |   |                       |   |                        |
|---|-----------------------|---|------------------------|
| 1 | Engine oil filler cap | 2 | Gearbox oil filler cap |
|---|-----------------------|---|------------------------|

Fig 5 Power pack, access plate removed

## Checking and topping up the engine oil

### WARNING

**VEHICLE MOVEMENT. THE DRIVER SHOULD NOT LEAVE THE VEHICLE WHEN THE ENGINE IS RUNNING UNLESS THEIR OWN SAFETY IS ENDANGERED**

- 7 The procedure for checking and topping up the engine oil is as follows:
  - 7.1 Stand the vehicle on level ground.
  - 7.2 Release the spring catch under the filler cap (Fig 5(1)) and raise the cover.
  - 7.3 Withdraw the dipstick, wipe it, re-insert it ensuring that it goes down fully, then withdraw it again and check for a presence of oil. Replace the dipstick and close the filler cap.
  - 7.4 Start the engine (Chap 2-7 refers) and run it until the coolant temperature is between 90.5 deg C and 93.3 deg C (195 deg F and 200 deg F).
  - 7.5 With the engine idling, re-check the oil level and top up to the full mark on the dipstick if necessary.

## Changing the engine oil

### WARNING

**PERSONAL INJURY. CARE MUST BE TAKEN WHEN DRAINING OILS FROM POWER PACK. THE ENGINE OIL COULD BE HOT AND A DANGER OF SCALDING IS POSSIBLE.**

- 8 The procedure for changing the engine oil is as follows:
  - 8.1 This servicing should be carried out when the engine has been started and the engine has run for approximately 5 minutes or movement begins to register on the engine coolant gauge.
  - 8.2 Stand the vehicle on level ground and switch off engine.
  - 8.3 Remove the access plug (Fig 6(6)) from the hull bottom plate.
  - 8.4 Remove the drain plug from the oil tank and allow the oil to drain into a clean suitably sized receptacle. Check the drain plug and washer for serviceability then replace and tighten securely.
  - 8.5 Replenish with fresh oil to the 'full' mark on the dipstick.
  - 8.6 Check and top up the oil Para 7 refers. Stop the engine and replace the access plug in the hull bottom plate.

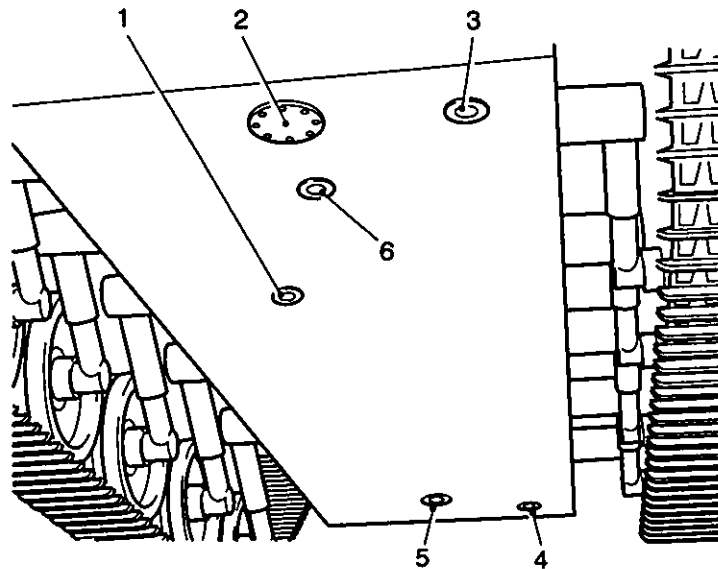

432/052

- |   |  |   |                               |
|---|--|---|-------------------------------|
| 1 | Gearbox drain access plug                            | 4 | Hull drain plug               |
| 2 | Steering unit drain access plate                     | 5 | Fuel drain valve access plate |
| 3 | Steering unit oil tank and coolant drain access plug | 6 | Engine oil drain access plug  |

Fig 6 Hull bottom plate

### Renewing the oil filter elements

9 This procedure can only be undertaken when the power pack is removed from the vehicle. The procedure for renewing the oil filter elements is as follows:

- 9.1 Remove nut retainer (Fig 7(16)) and slacken one centre bolt cap nut (1) in the filter head while supporting the filter bowl (4). Lower the bowl carefully so as not to spill the oil.
- 9.2 Pour the oil into a suitable container for disposal. Withdraw the element (5), the seal (7), the spring (8) and the washers (9 and 10). Dispose of the element in accordance with local regulations.
- 9.3 Clean all the components thoroughly and inspect for serviceability. Renew the components as necessary.
- 9.4 Fit onto the centre bolt (6) the rubber washer (10) the copper washer (9) the spring (8) and the cork seal (7).
- 9.5 Fit the new element (5) with the radial outlet holes uppermost.
- 9.6 Fill the bowl with clean oil of the correct grade (AESP 2350-T-250-601 refers). Fit the bowl to the head, ensuring it seats correctly. Replace the cap nut (1) and washer (2).
- 9.7 Repeat for the other bowl.



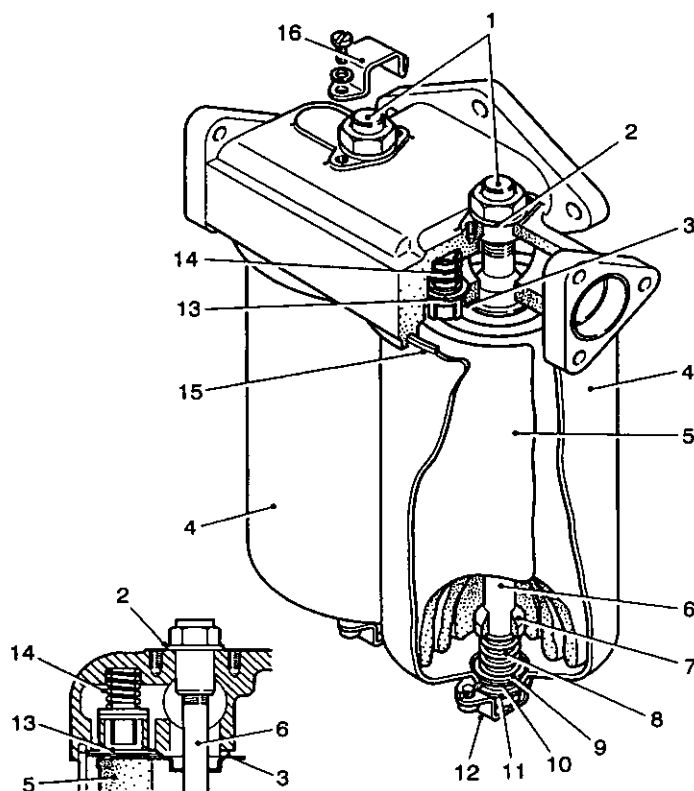

432/062

1	Cap nut	9	Copper washer
2	Copper washer	10	Rubber washer
3	Rubber washer	11	Washer
4	Bowl	12	Bolt retainer
5	Element	13	By-pass valve
6	Centre bolt	14	Valve spring
7	Cork seal	15	Rubber sealing ring
8	Spring	16	Nut retainer

Fig 7 Engine oil filter

**Cleaning the engine oil tank breather**

10 The procedure for cleaning the engine oil tank breather is as follows:

- 10.1 Open the air inlet louvre (Chap 2-2 refers).
- 10.2 Pull off the breather unit (Fig 8(6)) from the oil filler branch pipe.
- 10.3 Using approved cleaning agent, thoroughly clean the breather and allow it to dry.
- 10.4 Soak the breather in clean engine oil, allow the surplus oil to drain, and then wipe away any excess.
- 10.5 Refit the breather and close the air outlet louvre.

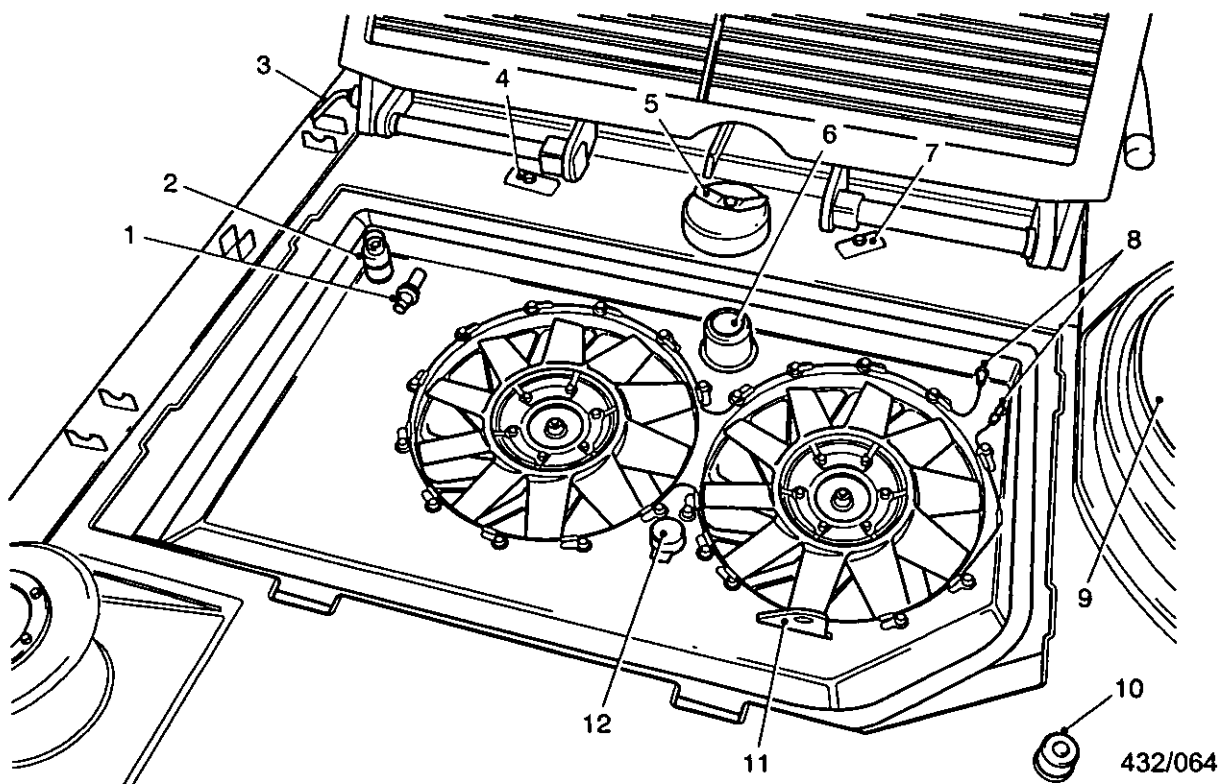

- |   |   |    |                                 |
|---|---|----|---------------------------------|
| 1 | Air cleaner indicator                   | 7  | Clamp plate                     |
| 2 | Hydraulic tank filler plug and dipstick | 8  | Firewire                        |
| 3 | Louvre retaining pin                    | 9  | Cupola                          |
| 4 | Clamp plate                             | 10 | Battery vent                    |
| 5 | Coolant filler cover                    | 11 | Lifting eye                     |
| 6 | Engine oil tank breather                | 12 | Engine crankcase breather cover |

Fig 8 Hydraulic fans

## FUEL FILTER

11 The main fuel filter (Fig 1(17)) is secured to a bracket welded to the power pack superstructure. An overflow valve is fitted in a pipe from the top of the filter, this is designed to relieve fuel pressure delivered to the fuel injection pump by allowing excess fuel to return to the main tanks. The valve is non-adjustable and, if necessary, is renewed as an assembly.

## Maintenance

### Cleaning the fuel filter

12 The procedure for cleaning the fuel filter is as follows:

- 12.1 Switch both battery switches to OFF, turn the fuel cock to OFF, fit the earth spike.
- 12.2 Remove the power pack access plate (Cap 2-2 Para 39 refers).
- 12.3 Pack cloth below the filter bowl (Fig 1(17)) or use a plastic bag to collect any fuel, which may spill.
- 12.4 Unscrew and remove the centre bolt (Fig 9(8)) while supporting the bowl (1).
- 12.5 Lower the bowl, pour off the fuel, and discard the element (2) in accordance with SOP.
- 12.6 Thoroughly, clean the bowl and the parts contained in it.

12.7 Examine for serviceability, filter head (3) and the seal in the head against which the bowl seals.

12.8 Examine for serviceability the washer (9) under the head of the centre bolt.

12.9 Using a new element and renewing any unserviceable part reassemble in the reverse sequence. Fill the bowl with fuel before assembling it to the head.

12.10 When assembled, turn the fuel cock to ON, slacken the knurled air bleed screw (7) on the filter head, then switch ON the battery switches and engine switch. Tighten the bleed screw immediately bubble-free fuel is expelled; switch OFF the engine switch.

12.11 Using suitable materials remove any spilt fuel. Replace the power pack access plate and stow the earth spike.

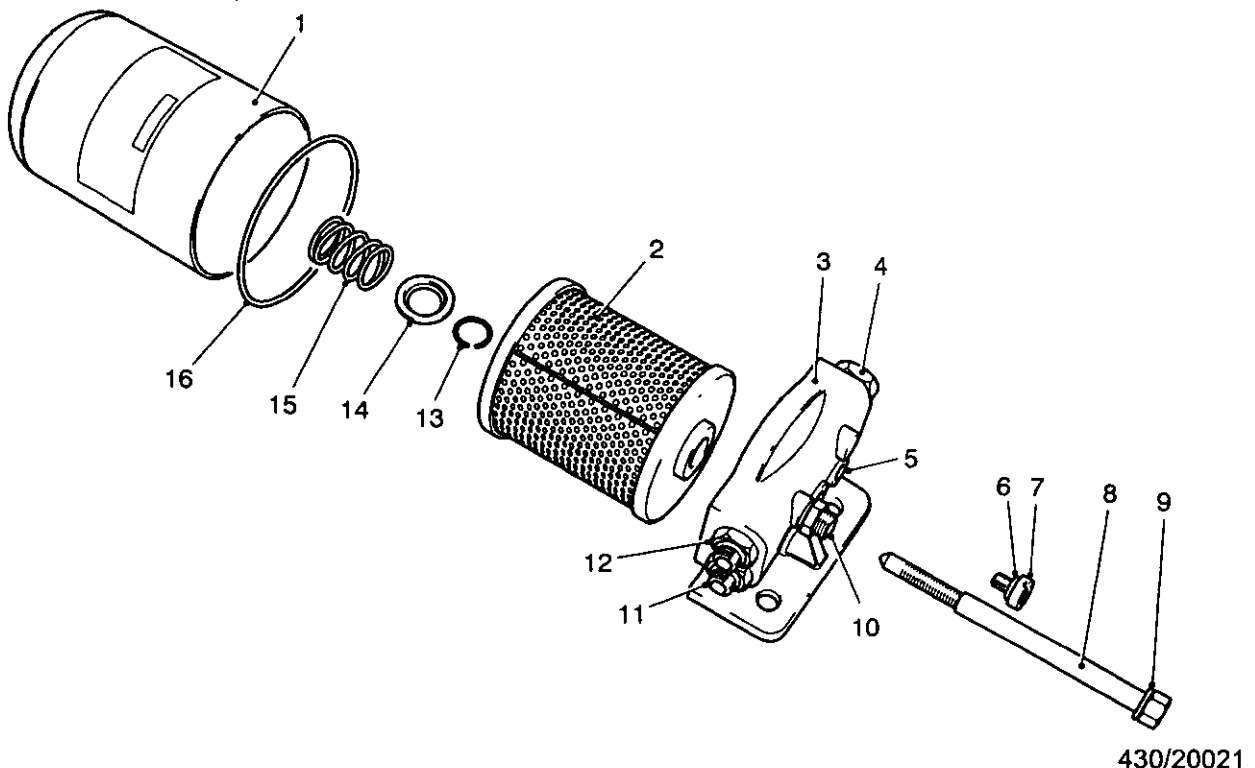

1	Bowl	9	Washer
2	Element	10	Leak 'OFF' connection
3	Head	11	Outlet
4	Plug	12	Inlet
5	Air bleed orifice	13	Circlip
6	Rubber washer	14	Spring seat
7	Air bleed screw	15	Spring
8	Centre bolt	16	O Ring

Fig 9 Fuel filter

## COOLING SYSTEM

13 The cooling system (Fig 10) comprises a header tank (3) with filler cap (2) a hydraulically driven fan (1), radiator (4), coolant pump (5), heat exchanger (9), thermostat (7) and drain (6).

14 When the engine is running, coolant is circulated round the cylinders and is then cooled again by being passed through a radiator. Before re-entering the engine it is circulated through a heat exchanger where, dependent on the relative temperatures, it cools or warms the engine oil, gearbox oil, steering unit oil and hydraulic oil for the fan drive.

15 Circulation of the coolant is by a pump. A thermostat fitted in the outlet on the engine causes the fan controller, radiator and heat exchanger to be by-passed while the engine is warming up so that the rise will be more rapid to an efficient working temperature. When this temperature is reached, the control unit in the coolant and fan drive circuits, operates, allowing oil to flow to the fan motors causing the fan to start rotating.

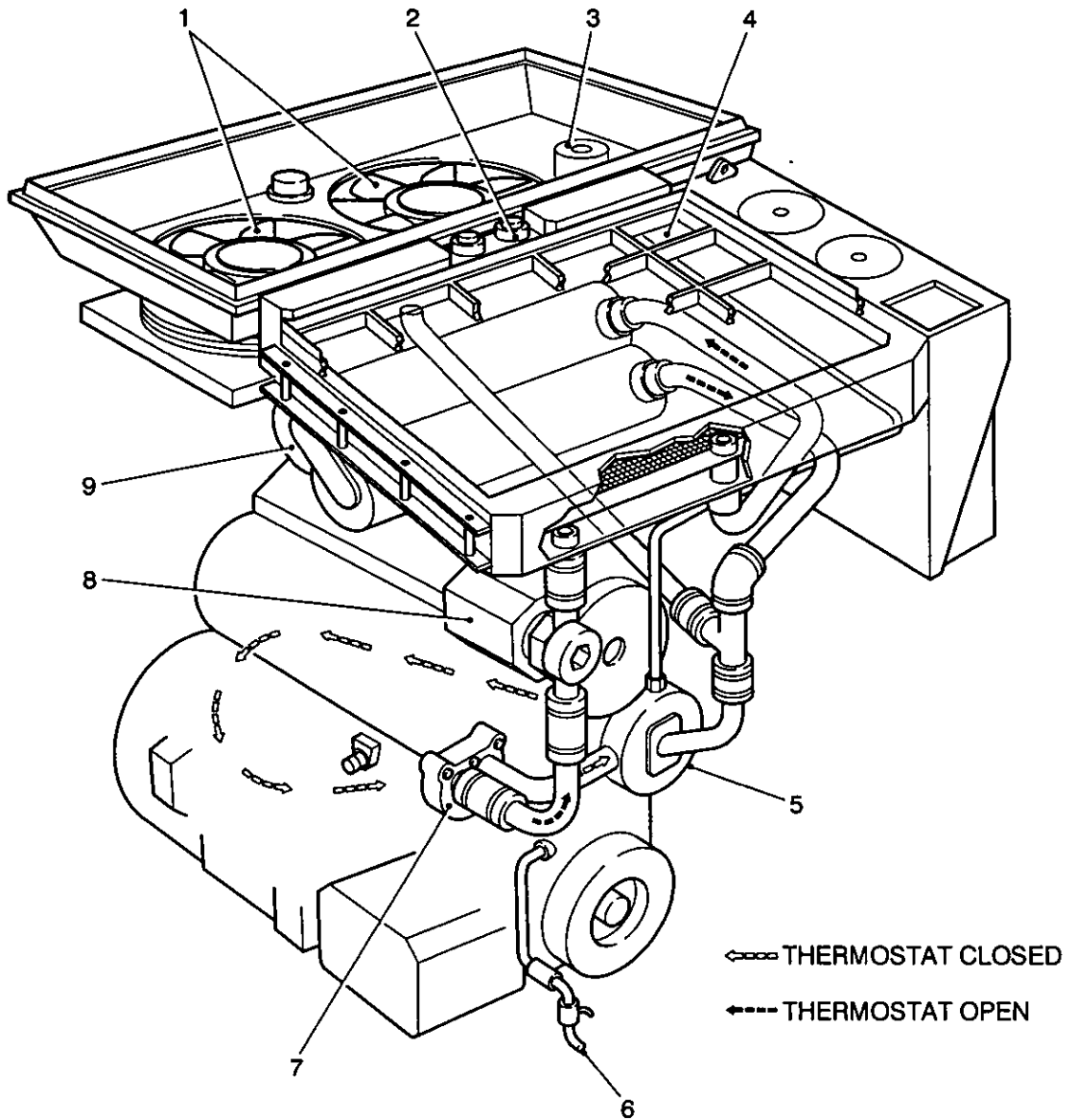

432/485

- |   |                   |   |                          |
|---|-------------------|---|--------------------------|
| 1 | Fans              | 6 | Drain                    |
| 2 | Filler cap        | 7 | Thermostat               |
| 3 | Expansion Tank    | 8 | Hydraulic fan controller |
| 4 | Two pass radiator | 9 | Heat exchanger           |
| 5 | Coolant-pump      |   |                          |

Fig 10 Cooling System

16 The fans draw air in through the inlet louvres and radiator, round the engine and expel it through the outlet louvres. The control unit varies the fan speed. This is to maintain the engine coolant at an efficient working temperature.

17 The coolant system is drained from the underside of the vehicle. Access to the drain plug is through the steering unit access cover.

**Checking and topping up the cooling system**

18 The procedure for checking and topping up the cooling system is as follows:

**WARNINGS**

(1) **PERSONAL INJURY. DO NOT REMOVE THE COOLANT FILLER CAP WHILE THE ENGINE IS RUNNING. ALWAYS WAIT UNTIL THE TEMPERATURE IS BELOW 93 deg C (200 deg F) BEFORE REMOVING THE COOLANT FILLER CAP OR SEVERE SCALDING MAY RESULT.**

(2) **TOXIC HAZARD. ANTI-FREEZE IS BOTH TOXIC AND HAZARDOUS. MINIMUM PRECAUTION AFTER USE IS TO WASH THE AFFECTED SKIN AREAS WITH SOAP AND WATER.**

(3) **HEAVY WEIGHT. THE POWER PACK ACCESS COVER IS EXTREMELY HEAVY. WHEN LIFTING/OPENING THE ACCESS COVER, CONSIDERATION SHOULD BE GIVEN TO THE REGULATIONS GOVERNING THE LIFTING OF HEAVY WEIGHTS.**

**CAUTION**

**EQUIPMENT DAMAGE.** Coolant may collect on top of the baffle so that at a glance a false impression of the level can be given.

18.1 Turn the handle on the filler cover (Fig 8(5)) to release the locking catch then lift out the cover.

18.2 Unscrew the filler cap, which is accessible through the cover aperture.

18.3 Add coolant, if necessary, to bring the coolant level up to the level of the radiator baffle plate, (approximately 38 mm (1½ in.) below the filler orifice). Do not overfill.

18.4 Replace the cap and cover.

**Draining, flushing, and refilling the cooling system**

19 The procedure for draining, flushing, and refilling the cooling system is as follows:

19.1 Remove the filler cover (Fig 11(4)) and cap.

19.2 Remove the access plug (Fig 6(3)) from the hull bottom plate.

19.3 Open the steering unit access cover, open the drain cock (Fig 10(6)) situated on the front of the power pack frame to the right of the crankshaft damper.

**NOTE**

The coolant contains anti-freeze mixture and should be drained in to a clean suitably sized receptacle.

19.4 Remove the receptacle, close the drain cock, and fill the system with clean water. Open the drain cock and, using a hosepipe or container to replenish the draining water, continue flushing until the water that is draining is clean.

19.5 Allow the system to drain completely, and then close the drain cock.

19.6 Fill the system with coolant and replace the filler cap and cover. If the coolant, which was drained, is to be re-used, ensure it is perfectly clean.

19.7 Start the engine and run the engine to normal operating temperature.

- 19.8 Stop the engine and re-check the level. Top up if necessary.
- 19.9 Check for leaks. If a leak in the system is found report to REME.
- 19.10 Replace the access plug and close the steering unit access cover.

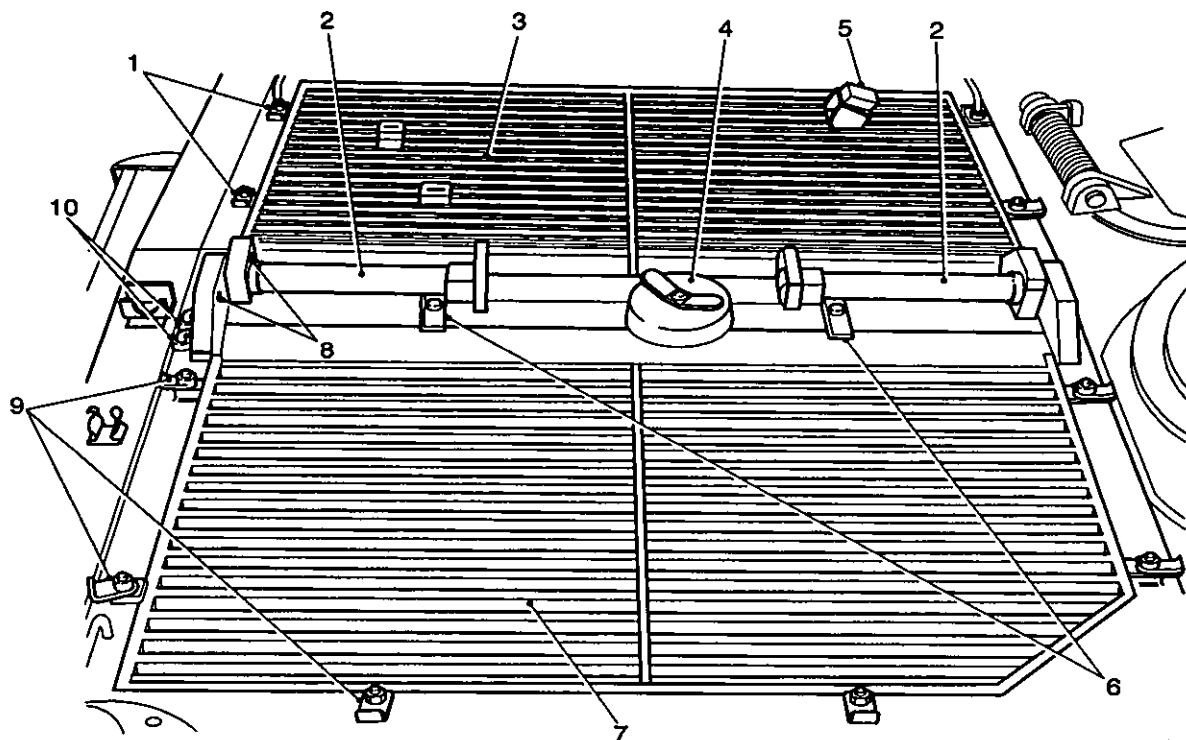

432/059

- |   |                      |    |                             |
|---|----------------------|----|-----------------------------|
| 1 | Turn-catch (open)    | 6  | Clamp plates                |
| 2 | Torsion bar tube     | 7  | Outlet louvre               |
| 3 | Inlet louvre         | 8  | Locking pin holes           |
| 4 | Coolant filler cover | 9  | Turncatch (closed)          |
| 5 | Driver's hatch stop  | 10 | Locking pin stowage bracket |

Fig 11 Power pack covers

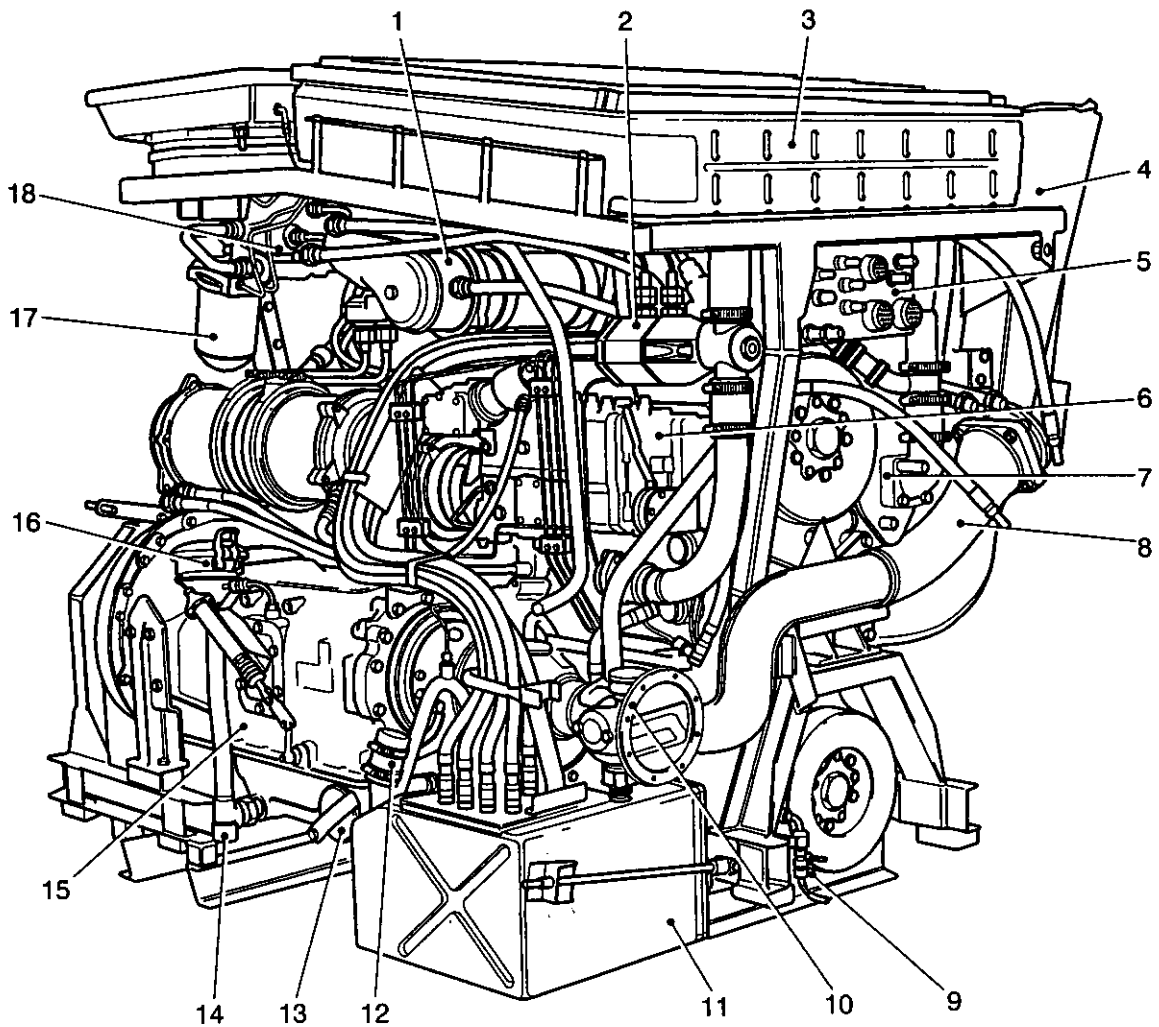

432/069

- |   |                           |    |                      |
|---|---------------------------|----|----------------------|
| 1 | Heat exchanger            | 10 | Gearbox coupling     |
| 2 | Fan controller            | 11 | Engine oil tank      |
| 3 | Radiator                  | 12 | Filler connection    |
| 4 | Air cleaner               | 13 | Gearbox filter cover |
| 5 | Power pack junction panel | 14 | Gearbox drain plug   |
| 6 | Injection pump governor   | 15 | Gearbox              |
| 7 | Coolant pump              | 16 | Gearbox oil filler   |
| 8 | Exhaust pipe              | 17 | Fuel filter          |
| 9 | Coolant drain cock        | 18 | Fan motor            |

Fig 12 Power pack, front right

### HYDRAULIC FAN DRIVE SYSTEM

20 The fans (Fig 10(1)) are driven hydraulically and the system comprises a pump (Fig 2(4)), a motor for each fan, a controller unit (Fig 10(8)), and a tank (Fig 2(10)) for the fluid. The fluid is passed through a section of the heat exchanger before being returned to the tank. The fan speed is controlled by coolant temperature and engine speed. The pump is shaft driven from the rear end of the engine. The controller is connected in both the coolant circuit and the hydraulic circuit and operates thermally. The thermostatic element in the controller is immersed in coolant, which, as it gets hot, causes the element to expand and gradually close the controller by-pass valve, which is in the hydraulic circuit.

21 When the engine is started from cold, the pump is rotated and fluid is drawn from the tank and delivered to the circuit. As the controller by-pass valve is almost wide open most of the fluid is returned to the tank via the section of the heat exchanger, so bypassing the fan motors. When the coolant temperature reaches that to which the controller is pre-reset, the expanding element further closes the by-pass valve and more fluid is diverted to the fan motors, which as the pressure builds up, begin to rotate faster. The heat of the coolant continues to close the by-pass causing the speed of the fans to increase until sufficient cooling is obtained to maintain the coolant at the pre-selected temperature.

### Checking the hydraulic fan drive tank oil level

#### NOTE

Loss of fluid should not normally occur, so if the fluid level is low, check the system for leaks before topping up. If a leak in the system is found report to REME.

22 The procedure for checking the hydraulic fan drive tank oil level is as follows:

22.1 Open the outlet louvre (Fig 11(7)).

22.2 Unscrew the filler plug (Fig 8(2)) and check that the breather holes are clear.

22.3 Withdraw the dipstick, wipe it, re-insert it, then withdraw it again, and check the fluid level indicated.

22.4 If the level is low, new hydraulic oil (AESP2350-T-250-601 refers) should be added, to bring the level up to the 'MAX' mark on the dipstick.

22.5 Replace the dipstick and filler plug and close the louvre.

### Draining and refilling the hydraulic system

23 This procedure can only be undertaken when the power pack is removed from the vehicle. The procedure for draining and refilling the hydraulic system is as follows:

23.1 Arrange a suitably sized container under the reservoir to receive the draining fluid then unscrew the drain plug (Fig 2(9)) until the fluid is flowing freely. The flow will continue until the lower tank is drained.

23.2 Remove the plug completely and allow the upper tank to drain. To accelerate the flow, remove the magnetic filters (1), (Para 24 refers) taking care to prevent entry of dust and dirt into the system.

#### CAUTION

**EQUIPMENT DAMAGE.** Always stand the filter on the brass plug head; never place it on its side, especially on steel or iron as this may cause loss of magnetism.

23.3 When the tank has completely drained, check that the joint washer is serviceable, and then refit the drain plug. Clean and refit the magnetic filters, (para 24 refers).

23.4 Refill the system with new hydraulic oil (AESP 2350-T-250-601 refers) through the filler (Fig 8(2)) of the reservoir up to the 'MAX' mark on the dipstick.

23.5 Run the engine for several minutes, re-check the fluid level, and top up as necessary. Check for leaks and report to REME if any found.



**Cleaning the hydraulic fan drive magnetic filters**

24 This procedure can only be undertaken when the power pack is removed from the vehicle. The procedure for cleaning the hydraulic fan drive magnetic filters is as follows:

24.1 Unscrew each filter from the top of the oil tank, covering the holes immediately to stop any dust or dirt getting into the tank.

**CAUTION**

**EQUIPMENT DAMAGE.** Always stand the filter on the brass plug head; never place it on its side, especially on steel or iron as this may cause loss of magnetism.

24.2 Holding the brass plug head (Fig 13(4)), remove the nut (1) and shake proof washer retaining the filter cage (2).

24.3 Withdraw the filter cage.

24.4 Wash the components thoroughly in an approved cleaning agent and wipe them clean.

24.5 Reassemble in the reverse sequence.

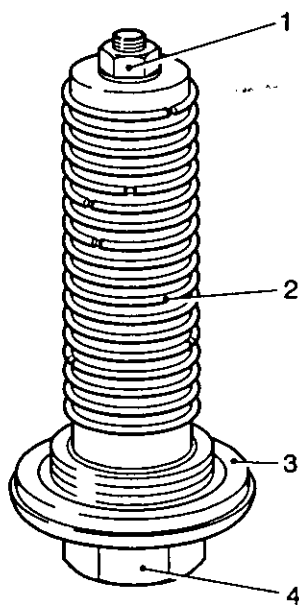

432/067

1 Nut  
2 Filter cage

3 Sealing washer  
4 Plug head

Fig 13 Magnetic filter

**AIR CLEANER**

25 The air supply to the engine is delivered via a two-stage air cleaner.

26 The first stage of the air cleaner (Fig 2(12)) is a cyclone type, which extracts the heavier particles of dirt. The particles fall to the bottom of the first stage compartment and are blown out of the compartment (11) by a stream of air by-passed from the blower unit.

27 The air supply passes from the first stage to a chamber (13) containing two replaceable paper elements by which the remaining dust is extracted.

28 When the second stage elements start to become choked and requires cleaning, an indicator unit (Fig 8 (1)) mounted on the fan cowling, which gives a visual warning. When the restriction has built up sufficiently, the green sleeve is drawn into the indicator body exposing the red coloured part of the indicator and the elements must be replaced or cleaned. When the elements have been replaced or cleaned, reset the indicator by pressing the rubber button on the end of the unit. If the red portion again covers the green as soon as the engine is run report to REME.

### Changing the air cleaner elements

29 The procedure for changing the air cleaner elements is as follows:

29.1 Open the inlet louvre (Chap 2-2 refers).

29.2 Unscrew the captive wing nuts (Fig 14(8)), and then lift off the covers (7) from the secondary stage chamber.

29.3 Unscrew the captive wing nuts (3), and then lift out each element by the rings provided and discard the elements; should replacement elements not be available, the vehicle is to be sentenced 'VOR'. Under no circumstances are the filters to be shaken or banged to remove debris and replaced. Unserviceable filters must be discarded.

29.4 Insert each new element (or cleaned ones) and secure them with the wing nuts; replace the covers, ensuring that the rubber seals are undamaged and secure the wing nuts.

29.5 Close the air inlet louvre.

29.6 Open the outlet louvre (Fig 11(7)) and reset the air cleaner indicator (Fig 8(1)), then close the louvre.

### NOTE

If the elements have been re-used, replacement elements must be obtained and fitted as soon as possible.

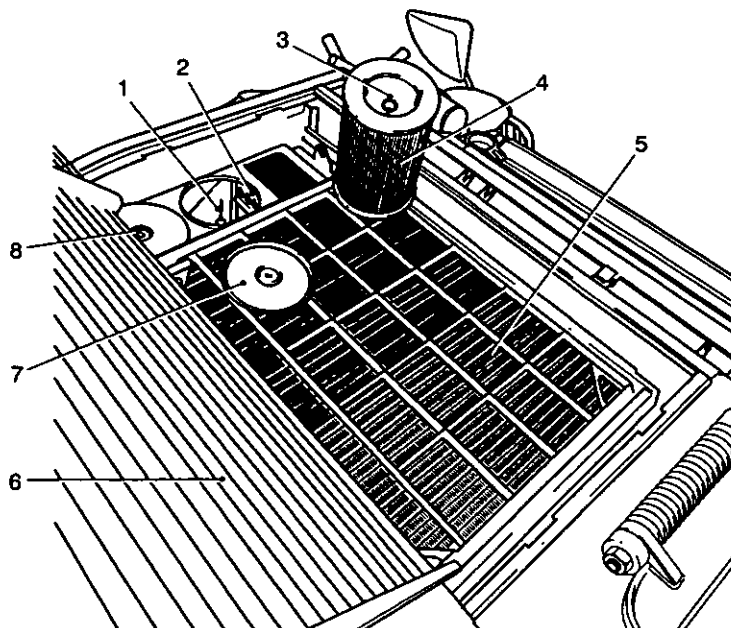

432/068a

- 1 Element securing bolt
- 2 First stage air cleaner
- 3 Captive wing nut
- 4 Second stage element

- 5 Radiator
- 6 Air inlet louvre
- 7 Cover
- 8 Captive wing nut

Fig 14 Air cleaners and radiator

## TRANSMISSION

### Gearbox

30 The vehicle is fitted with an Allison TX200-4A, hydraulically operated, semi automatic gearbox (Fig 1(15)). It comprises a 3-element torque converter, with an automatic lock up clutch, epicyclic gearing and speed range clutches.

31 Six forward speed ranges and one reverse range is manually selected, automatic gear changes take place in each forward speed range.

32 The torque converter is a hydraulic coupling used to replace a conventional clutch. It provides an infinite variation in drive, from full slip to 1:1 drive.

### Transfer gearbox

33 The purpose of the transfer gearbox (Fig 2(5)) is to transfer the output of the engine across the rear of the pack to the input of the gearbox. It provides, through a dog clutch, a simple means of disconnecting the engine from the transmission to make starting easier in cold weather, and provides a power take off if required.

### Checking the gearbox oil level and topping up

34 The procedure for checking the gearbox oil level and topping up is as follows:

34.1 Cold check Open the gearbox filler access cover (Fig 15(1)) on the power pack compartment partition sill and open the hinged filler cap (Fig 5(2)), withdraw the dipstick, wipe it, re-insert it, withdraw it again and check to ensure there is sufficient oil to allow the engine to be started. The 'safe to start' level is approximately 25.4 mm (1 in.) above the 'SAFE RANGE' zone upper mark on the dipstick.

34.2 Hot check Drive the vehicle for approximately 5 km (3 miles) ensuring that all gears, including reverse, are selected.

34.2.1 When the gearbox oil temperature reaches 82 deg C (180 deg F) that is indicated by a yellow line on the gearbox temperature gauge (AESP 2350-T-250-821 Misc Instr No 1/15), stop the vehicle on level ground.

34.2.2 Move the gear selector lever to neutral and run the engine at 2,000 rev/min for 15 seconds to purge the air from the gearbox lubrication system.

34.2.3 Reduce the engine speed over a 4 second period to 800 rev/min.

34.2.4 Wait one minute with the engine idling at 800 rev/min, then with a temperature gauge reading of 82 deg C (180 deg F), check the gearbox oil level reading on the dipstick. The ideal level is in the centre of the 'SAFE RANGE' zone but if it is anywhere within the zone the vehicle can be used safely.

### NOTE

Do not rush the check; the oil level will remain stable for approximately 3 minutes.

34.2.4 If the oil level is outside the 'SAFE RANGE' zone, the vehicle must not be run and REME informed.

35 Between checks, when running the vehicle, observe the gearbox temperature gauge at frequent intervals and ensure that the temperature is within the normal range 82 deg C - 105 deg C (180 deg F - 220 deg F). If the temperature should rise to 121 deg C (250 deg F) indicated in red on the gearbox temperature gauge (AESP 2350-T-250-821 Misc Instr No 1/15), stop the engine and REPORT to REME.

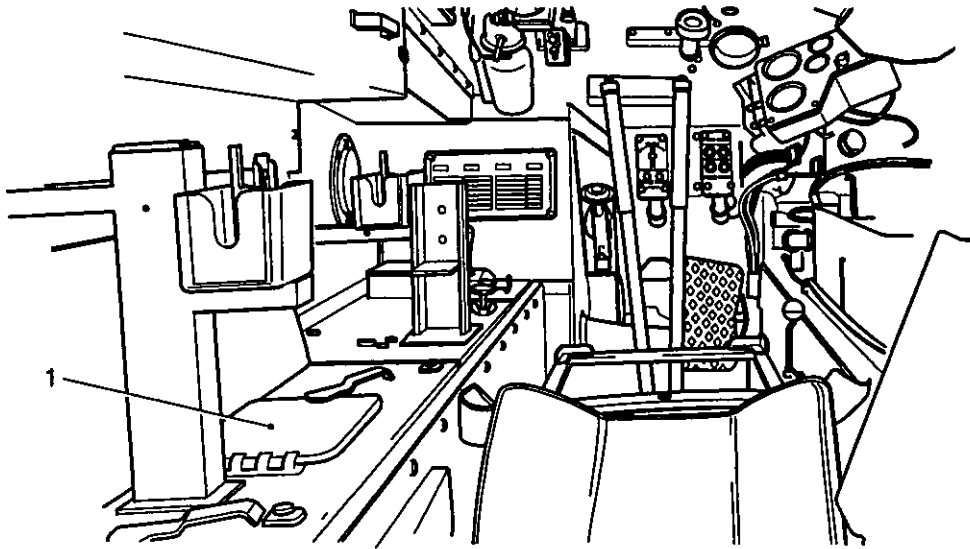

432/011a

- 1 Gearbox filler access cover

Fig 15 Driver's compartment

#### Changing the gearbox oil (power pack removed)

36 The procedure for changing the gearbox oil with the power pack removed, is as follows:

- 36.1 Place in position a suitable sized container to collect the oil. Remove the gearbox drain plug (Fig 1(14)) from the bottom end of the gearbox filler pipe and allow the oil to drain.
- 36.2 When oil has finished draining, change the oil filter element (see Para 37). Check that the washer and plug are serviceable and replace.
- 36.3 Refill the gearbox to one inch above the 'SAFE RANGE' zone upper mark on the dipstick.
- 36.4 Check and top up if necessary as in Para 34

#### Changing the gearbox oil filter element

37 The procedure for changing the gearbox oil filter element is as follows:

- 37.1 Place beneath the end cover, (Fig 16(1)) a suitable container or sufficient cloth to absorb any oil that may be present in the element housing.
- 37.2 Release the filter end cover retaining strap (5) and swing it to one side. Do not remove the nut from the bolt (6).
- 37.3 Remove the filter end cover (1).
- 37.4 Withdraw the element retainer (2), which positions the element.
- 37.5 Withdraw the element (4) and dispose of in accordance with local regulations.
- 37.6 When all oil has drained from inside the filter housing, clean the housing and the parts removed.
- 37.7 Inspect the parts and exchange, any which are not serviceable.

- 37.8 Insert the new element in the housing ensuring that the inner end is correctly located. This can be done by moving the element up and down and crosswise until it is felt to seat correctly.
- 37.9 Holding the element in position fit the element retainer (2) with its seal ring (3) fitted.
- 37.10 Replace the end cover, refit, and tighten the end cover-retaining strap.

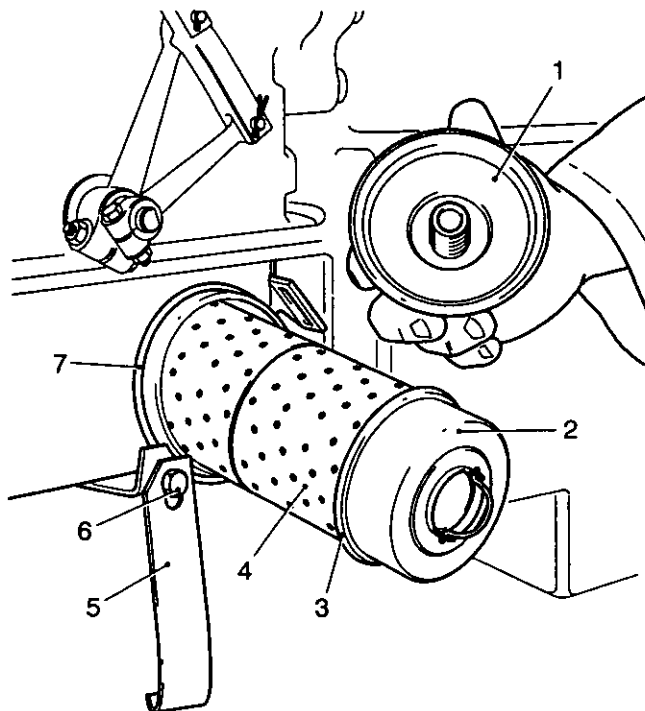

432/070

1	End cover	5	End cover retaining strap
2	Element retainer	6	Bolt
3	Seal ring	7	Seal ring
4	Filter element		

Fig 16 Gearbox oil filter

**Changing the gearbox oil (power pack fitted)**

- 38 The procedure for changing the gearbox oil with the power pack fitted, is as follows:
- 38.1 Ensure the oil is still warm after the vehicle has been run.
- 38.2 Remove the access plug (Fig 6(1)) from the bottom plate and place a suitable receptacle beneath the access to collect the draining oil. Slide the driver's seat clear of the slides (see Chap 2-2).
- 38.3 Remove the two bolts securing the driver's seat base frame at the rear, and tilt it fully forward.
- 38.4 Ensure the radio battery switched to OFF.
- 38.5 Slacken the two nuts on the battery clamp bolts, (Fig 17(5)) securing the battery clamp bar and remove the bar (6).
- 38.6 Disconnect the cable from the negative terminal (2) on the battery, carefully lift the rubber cover from the positive terminal to obtain access to the connector and then disconnect. Similarly, disconnect the battery inter-connector from one of the terminals.

- 38.7 Withdraw the flexible vent tubes from the batteries and carefully lay the tube assembly (3) to one side.
- 38.8 Lift out the batteries then remove the glass fibre container.
- 38.9 Remove the access plate (9) from the power pack compartment division plate.
- 38.10 Remove the filter element; Para 37 refers.
- 38.11 Replace the components in the reverse sequence.
- 38.12 Refill the gearbox to 25.4mm (one inch) above the 'SAFE RANGE' zone upper mark on the dipstick.
- 38.13 Check and top-up if necessary as in Para 34.

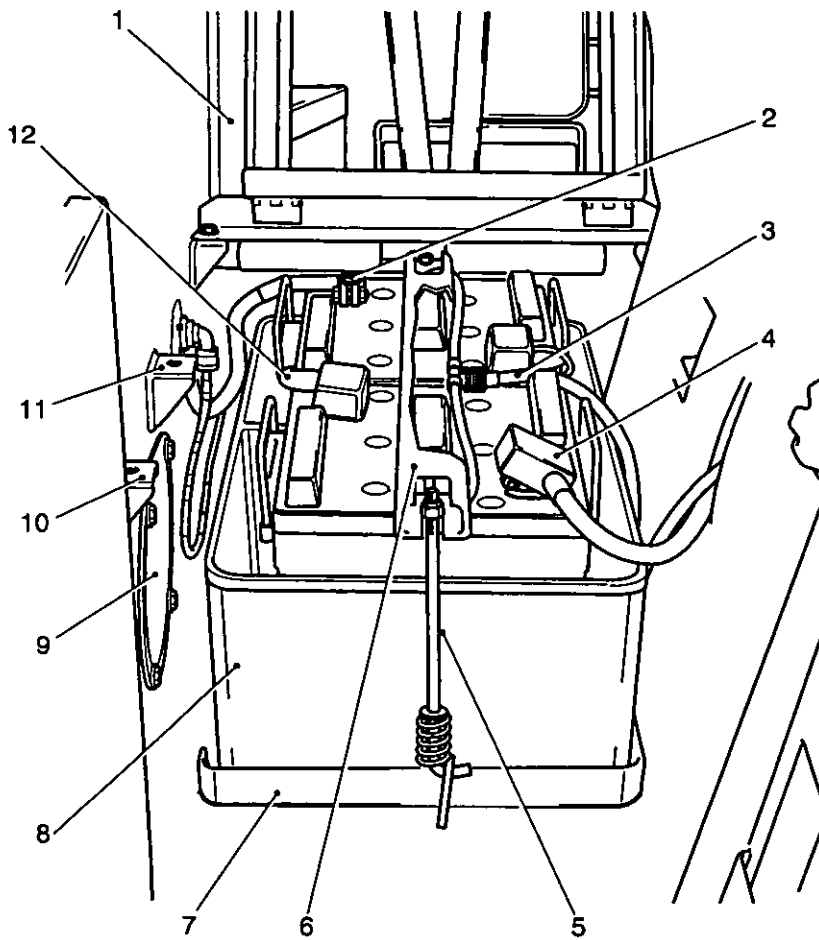

430/20087

- |   |                             |    |                              |
|---|-----------------------------|----|------------------------------|
| 1 | Seat frame                  | 7  | Container housing frame      |
| 2 | Negative terminal           | 8  | Container                    |
| 3 | Vent tube assembly          | 9  | Access plate, gearbox filter |
| 4 | Rubber cover                | 10 | Footrest bracket             |
| 5 | Battery clamp bolt          | 11 | Seat bracket                 |
| 6 | Battery clamp bar (removed) | 12 | Inter-connector              |

Fig 17 Radio batteries (Maintenance free)

**Gearbox coupling lubrication**

39 Two lubricating nipples (Fig 18(2)) are fitted to the coupling, one on each universal joint. Lubricate using a grease gun until grease exudes from the relief valves.

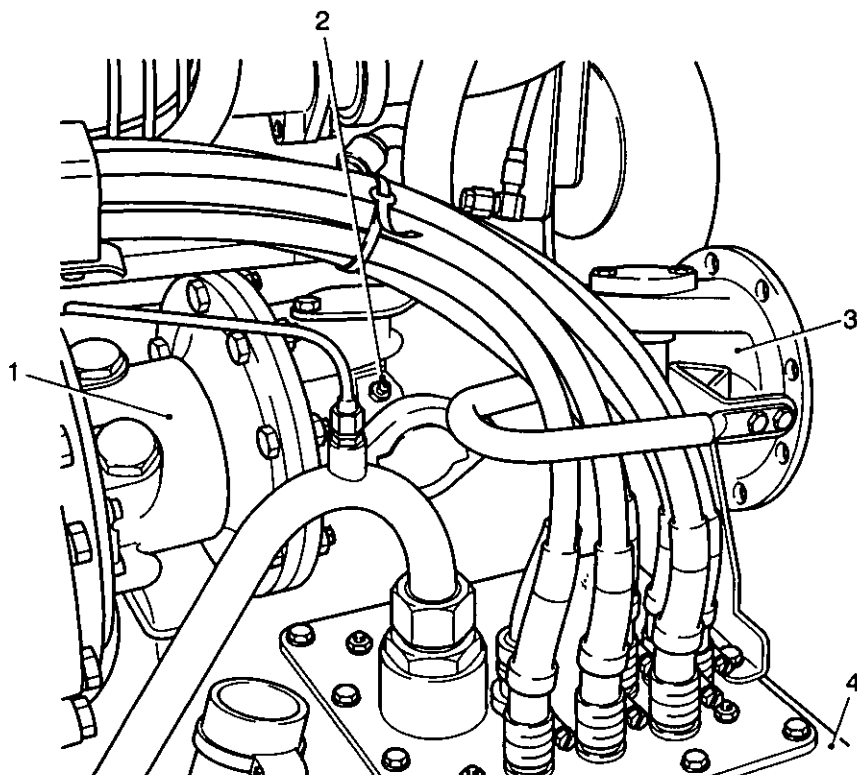

432/071

1 Gearbox  
2 Lubricating nipples

3 Gearbox coupling  
4 Engine oil tank

Fig 18 Gearbox coupling

CHAPTER 2-4  
FINAL DRIVE, SUSPENSION AND TRACKS

CONTENTS

Para

	Introduction
1	General
2	Vehicle tools
3	Final drive
4	Checking and topping up the final drive oil level
5	Changing the final drive oil
6	Final drive hub lubrication
7	Steering unit
9	Checking the oil level and topping up
10	Changing the oil
11	Cleaning the breather
12	Suspension (WARNING)
13	Suspension units
14	Road wheel hubs
15	Axle arm bearing
16	Road wheels
17	Road wheel nuts (CAUTION)
18	Raising a road wheel using the axle arm-jacking strut (WARNING)
19	To remove and refit roadwheels
20	Removing the axle arm-jacking strut and lowering the road wheel (WARNING)
21	Torsion bars
22	Track adjusters
24	Checking the track adjuster
25	Lubrication of the track adjusters
26	Guide rollers
27	Tracks
31	Track inspection (WARNINGS)
36	Track tension
37	Checking the track tension
38	Adjusting the track tension
40	Breaking and removing a track (WARNINGS)(CAUTION)
41	Moving the vehicle with one track removed
42	Replacing a track
43	Final drive sprocket rings
44	Reversal, removal and refitting of sprocket rings
45	Inspection

Fig

Page

1	Final drive and suspension layout .....	2
2	Final drive sprocket.....	3
3	Front of vehicle .....	5
4	Steering brake linkage.....	5
5	Suspension unit .....	7
6	Jacking strut.....	9
7	Track adjuster.....	10
8	Rubber bushed and padded track .....	11
9	Track splitting / joining .....	15
10	Attaching track rope and using sprocket as a capstan.....	16
11	Sprocket ring wear indicator .....	18
12	Final drive sprockets.....	19
13	Final drive sprockets (reversed).....	20



**INTRODUCTION**

**General**

1 This chapter describes the operation and maintenance tasks required on the final drive, suspension and tracks. A schematic layout of the final drive and suspension system is shown in Figure 1.

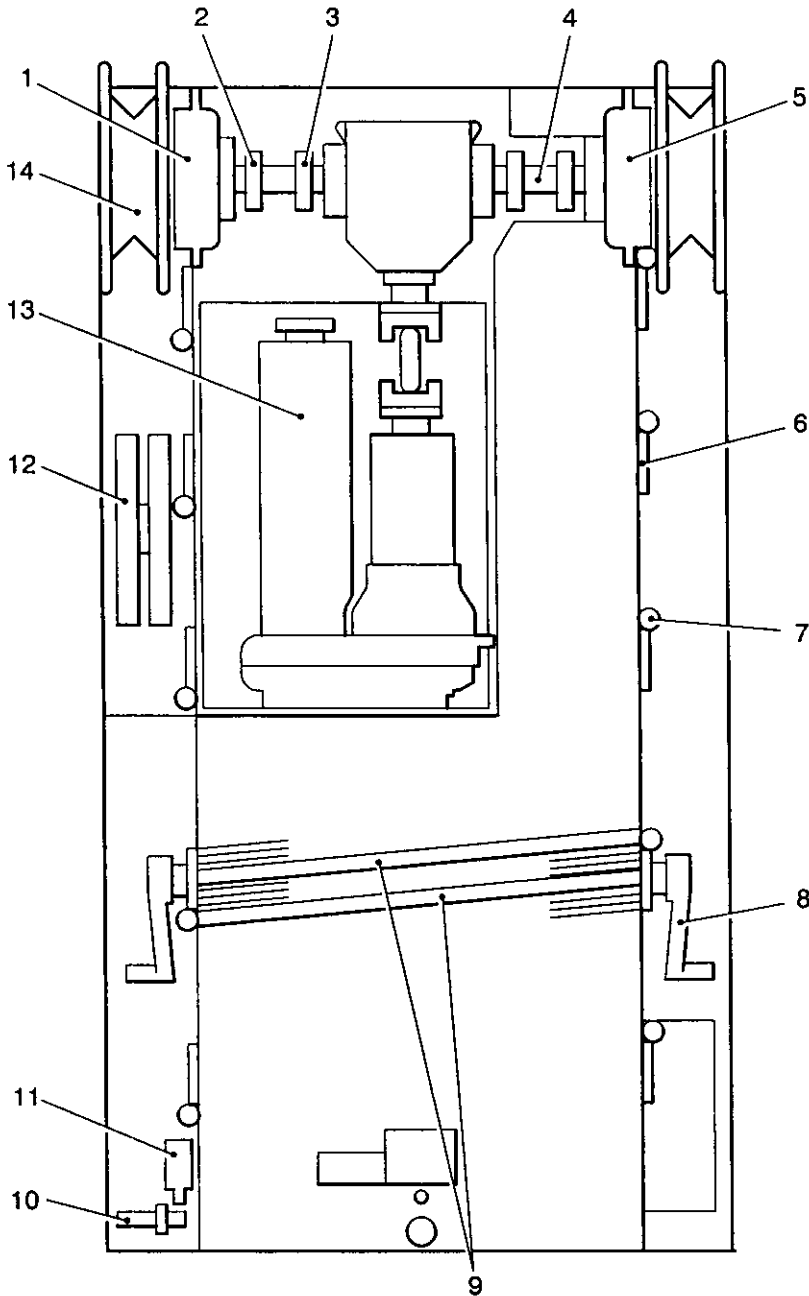

432/486

- |   |                             |    |                    |
|---|-----------------------------|----|--------------------|
| 1 | LH Final drive              | 8  | Axle arm           |
| 2 | Muff Coupling               | 9  | Torsion bars       |
| 3 | Muff Coupling               | 10 | Idler Arm          |
| 4 | Half shaft Axle arm housing | 11 | Track adjuster arm |
| 5 | RH Final drive              | 12 | Road wheels        |
| 6 | Axle arm housing            | 13 | Power Pack         |
| 7 | Anchor block                | 14 | Left sprocket      |

Fig 1 Final drive and suspension layout

## Vehicle tools

2 Vehicle tools associated with the final drive, suspension and tracks for this vehicle are listed in AESP 2350-T-250-741.

## FINAL DRIVE

3 Drive from the power pack is transmitted to the track driving sprockets through the steering box to the couplings (2,3 and 4) and final drives (1 and 5). The final drives are reduction gearboxes and their casings serve as a mounting for the gear assemblies, and as a reservoir for oil to lubricate the gears and bearings. Each casing is provided with a filler/drain plug (Fig 2(1) to enable oil level filling, draining and checking and a lubricating nipple (2) in the face of each hub provides the means to feed grease into the space between the final drive outer casing and the labyrinth a lubricator. The RH unit drives the speedometer.

### Checking and topping up the final drive oil level

4 The procedure for checking and topping up each final drive oil level is as follows:

4.1 With the vehicle on a level standing, clean the area around the filler plug (Fig 2 (1) and then remove the filler plug from the top of the elbow on the casing.

4.2 Check that the oil level is up to the bend of the elbow. Add oil if necessary to the correct level. Allow sufficient time for the oil to find its true level (AESP 2350-T-250-601 refers).

4.3 Replace the filler plug.

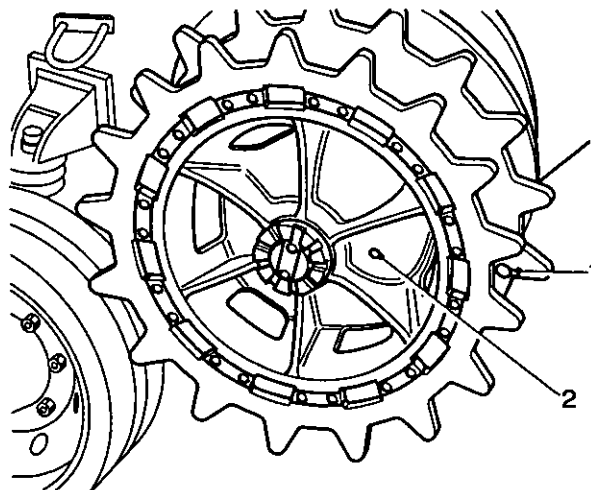

432/074

1 Filler plug

2 Lubricating nipple

Fig 2 Final drive sprocket

### Changing the final drive oil

5 The procedure for changing the oil in each final drive is as follows:

5.1 Park the vehicle on a level standing.

5.2 Clean the area round the filler plug, and then remove the plug (Fig 2(1)) from the top of the elbow on the casing.

5.3 Place a suitable receptacle under the drain plug, remove the plug and allow the oil to drain.

5.4 When the oil has completely drained, replace the drain plug and washer after checking for serviceability. Tighten securely.

5.5 Fill through the filler elbow until the oil level is up to the bend in the elbow. Allow sufficient time for the oil to find its true level (AESP 2350-T-250-601 refers).

- 5.6 Replace the filler plug.

### Final drive hub lubrication

6 A lubricating nipple (Fig 2(2)) in the face of each hub provides the means to feed grease into the space between the final drive outer casing and the labyrinth. Grease (AESP 2350-T-250-601 refers) should be injected until clean grease can be seen coming from the inner end of the hub.

### STEERING UNIT

7 The steering unit directs the power from the pack to the left and right sides of the vehicle through a crown wheel and pinion.

8 The unit contains a spur gear differential, which can be controlled by adjustable brakes, which when applied individually, varies the speed of the outputs thus causing the vehicle to steer.

### Checking the oil level and topping up

9 The procedure for checking the steering unit oil level and topping up, is as follows:

- 9.1 Stop the vehicle on level ground.
- 9.2 Remove the domed plug (Fig 3(1)) in the front sloping plate of to the left of the steering unit access cover (2).
- 9.3 Withdraw the dipstick, wipe it, re-insert it, ensuring it goes right down, withdraw it again and check the oil level.
- 9.4 Add oil, if necessary, to bring the oil level to the 'MAX' mark on the dipstick. Do not overfill.
- 9.5 Replace the dipstick and replace the domed plug.

### Changing the oil

10 The procedure for changing the steering unit oil, is as follows:

- 10.1 Ensure the oil is still warm after the vehicle has been run and stop the vehicle on level ground.
- 10.2 Position a suitably sized receptacle under the vehicle and remove the access plug under the oil tank and the access plate from under the steering unit.
- 10.3 Remove the drain plugs from the oil tank and the steering unit.
- 10.4 Check the drain plugs and washers for serviceability and replace when the oil has completely drained. Tighten the plugs securely.
- 10.5 Refill with oil, check the level and top up as Para 9.4.
- 10.6 Replace the access plug and plate, ensuring that both make watertight joints.

### Cleaning the breather

11 The procedure for changing the steering unit breather is as follows:

- 11.1 Open the steering unit access cover (Fig 3 (2)).
- 11.2 Pull the breather (Fig 4(1)) off the atmosphere pipe.
- 11.3 Wash the breather using an approved cleaning agent, and then allow it to drain.
- 11.4 Re-oil the steel wool allowing any surplus oil to drain before replacing.

11.5 Wipe the breather lean and refit.

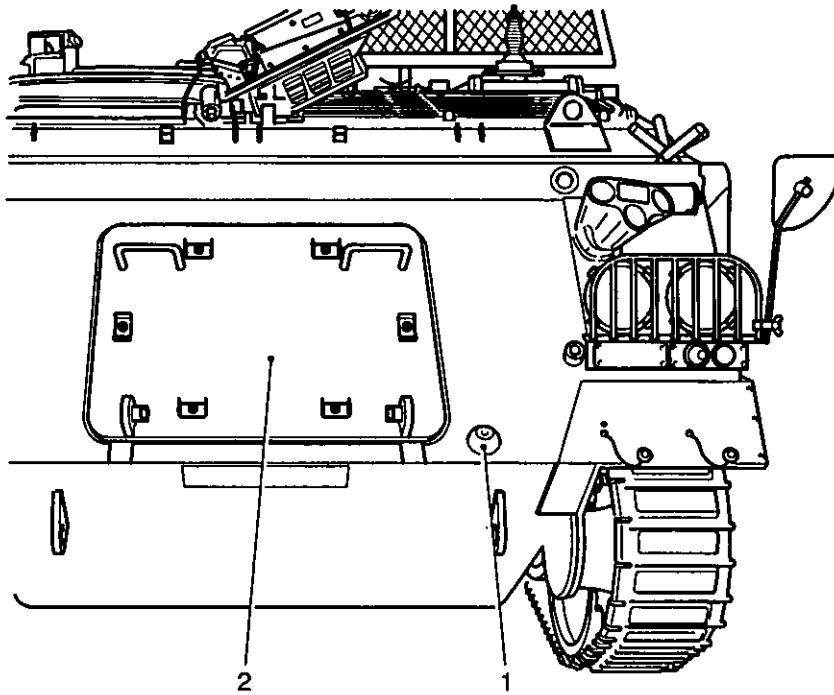

430/20109

1 Steering unit oil tank access plug

2 Steering unit access cover

Fig 3 Front of vehicle

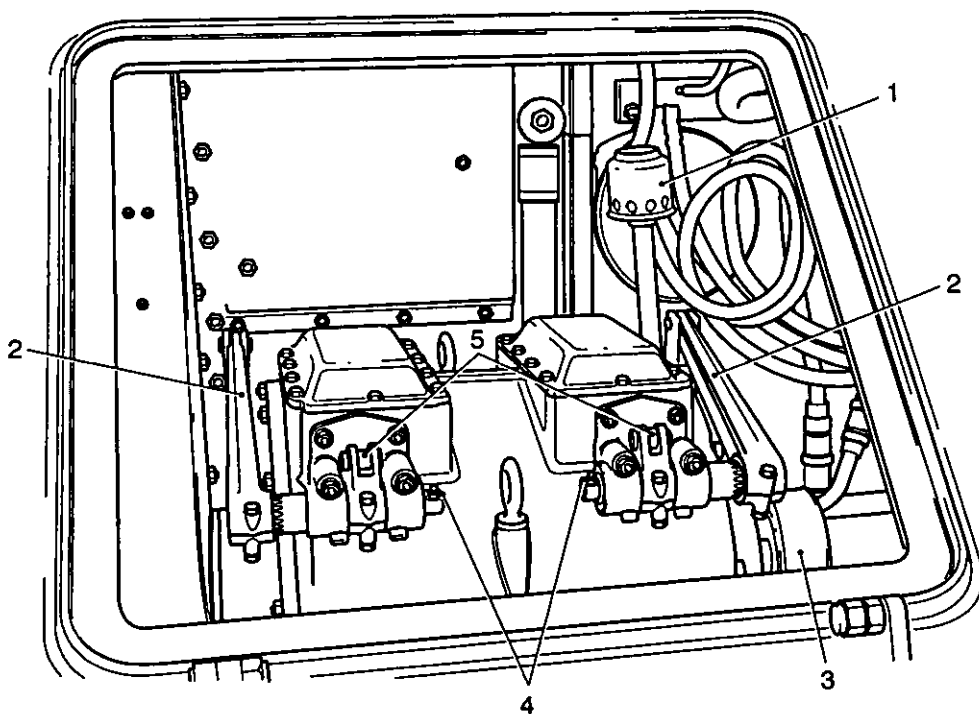

432/072

1 Steering unit breather  
2 Brake operating lever  
3 Half shaft coupling

4 Lubricators  
5 Rollers

Fig 4 Steering brake linkage

## SUSPENSION

### WARNING

**SAFETY HAZARD. BEFORE PERSONNEL ARE ALLOWED UNDERNEATH, THE VEHICLE IS TO BE PARKED ON FIRM LEVEL GROUND WITH THE PARKING/STEERING BRAKE FULLY APPLIED, THE ENGINE STOPPED, AND THE VEHICLE SECURED AGAINST ANY MOVEMENT.**

12 Each side of the vehicle is supported on each side by five suspension stations (Fig 4). Each station comprises of a transverse torsion bar (Fig 1(9) and on trailing axle arm suspension arrangement (8), carrying twin rubber tyred road wheels (12). Each track forms a continuous flexible surface for the vehicle to run on, with the drive transmitted to the track by a sprocket (14) fitted to the final drive (1 and 5). The sprocket (14), two support/guide rollers, and idlers wheels on a track tensioner assembly (11) support the top-run of the track.

### Suspension units

13 Each suspension unit (Fig 5) comprises of an axle arm (8), shock absorber (13), road wheel hub (3), a pair of wheels, bump stop (2) and a guide roller. The axle arm's upward travel is limited by a rubber/steel bump stop. Each pair of wheels is mounted on the road wheel hub, which revolves on a stub axle. The axle arm pivots in two bushes in a bracket welded to the hull. The pivot tube of the axle arm is connected to a torsion bar, which extends across the hull to a fixture on the axle arm bracket on the opposite side.

### Road Wheel hubs

14 Each road wheel hub is lubricated by means of a filler/level plug (Fig 5(5)). The track adjusting wheel hubs are similarly lubricated. The plug is brought to the correct position for filling by turning the hub to bring an arrow (4), cast on the face of the hub, to the 12 o clock position.

- 14.1 With the arrow in the 12 o clock position, remove the plug.
- 14.2 Add oil to the level of the plughole (AESP 2350-T-250-601 refers).
- 14.3 Check that the plug and washer are serviceable, then replace and tighten the plug.

### Axle arm bearings

15 The axle arm bearings are lubricated through two nipples on either side of each axle arm housing. Inject 15 shots of grease with a grease gun into each nipple (AESP 2350-T-250-601 refers).

### Road wheels

16 The road wheels comprise of twin rubber tyred wheel discs bolted on to hubs. The individual wheels are fully interchangeable.

### Road wheel nuts

### CAUTION

**EQUIPMENT DAMAGE. If for any reason the wheel nuts have been slackened and re-tightened, they must be checked for tightness daily for the next three days that the vehicle is operated. One man using the torque wrench supplied for this purpose must tighten the wheel nuts. Pipes, bars etc must not be used to increase the leverage, as the torque must not exceed 163 nm (120 lb/ft).**

17 The tightness of each nut securing the road wheels must be checked or tightened in a diagonal sequence (AESP 2350-T-251-601 refers).

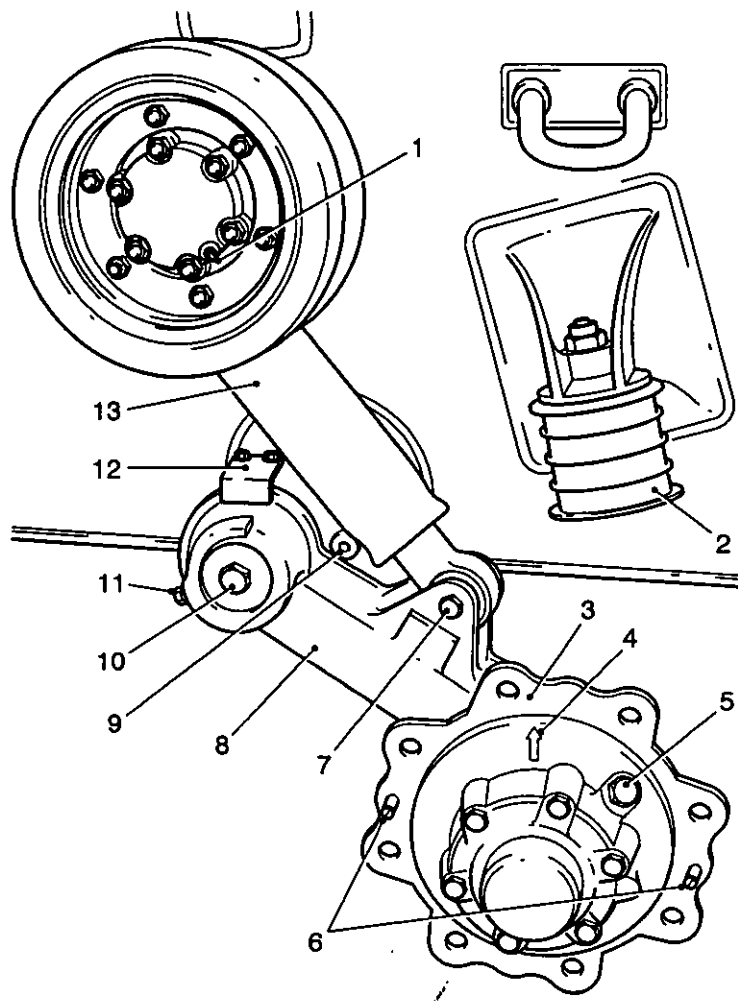

430/20052

- |   |                                 |    |                                    |
|---|---------------------------------|----|------------------------------------|
| 1 | Guide roller lubricating nipple | 8  | Axle arm                           |
| 2 | Bump stop                       | 9  | Torsion bar access plug, inner end |
| 3 | Road wheel hub                  | 10 | Torsion bar access plug, outer end |
| 4 | Arrow                           | 11 | Locking screw                      |
| 5 | Filler level plug               | 12 | Retaining plate                    |
| 6 | Wheel locating pins             | 13 | Shock absorber                     |
| 7 | Shock absorbing mounting bolt   |    |                                    |

Fig 5 Suspension unit

### Raising a road wheel using the axle arm jacking strut

#### WARNING

**PHYSICAL INJURY. ENSURE THAT THE VEHICLE IS IN NEUTRAL AND THE PARKING BRAKE IS APPLIED BEFORE CLIMBING UNDER THE VEHICLE AND LOCATING THE JACKING STRUT. ENSURE THE TOOL IS CLEAN. NO PERSON IS TO REMAIN UNDER THE VEHICLE WHEN VEHICLE IS BEING MOVED TO LIFT WHEEL STATION.**

18 To raise wheels using a jacking strut (Fig 6), proceed as follows:

18.1 Halt vehicle on firm level ground.

18.2 Apply steering/parking brake and stop engine.

18.3 Locate the jacking strut (Fig 6(5) AESP 2350 2350-T-250-741 refers)), using the end with the larger radius, in the vee formed between the distance piece (1) and the axle arm (3), with the lug fitted within the wheel rim. Position the track end of the strut on the track in line with the sprocket tooth slots (6). The strut can be inclined towards the front or rear of the vehicle.

- 18.4 Check that all personnel are clear of the vehicle.
- 18.5 Start engine and select reverse gear range.
- 18.6 Release steering/parking brake and ease vehicle rearward, until strut is vertical (5).
- 18.7 Apply steering/parking brake fully and stop engine.
- 18.8 Apply parking brake and stop engine.

**To remove and refit road wheels**

- 19 19 To remove and refit a pair of road wheels, proceed as follows:
  - 19.1 Park vehicle on firm level ground, fully apply parking brake and stop engine.
  - 19.2 Slacken nuts of road wheel to be removed, one complete turn.
  - 19.3 Jack up wheel station as detailed in Para 18.
  - 19.4 Remove wheel nuts and remove wheels from hub, taking care not to damage the wheel studs.
  - 19.5 Fit road wheels using the reverse of removal sequence after making sure that mating faces of wheels, hub, studs and nuts are clean and undamaged.
  - 19.5 Lower the wheel station as detailed in Para 20 and with wheels in lowered position, torque road wheel nuts in diagonal sequence to 163Nm (120lbf/ft).

**Removing axle arm jacking strut and lowering the road wheel****WARNING**

**SAFETY HAZARD. BEFORE PERSONNEL ARE ALLOWED UNDER THE VEHICLE, THE STEERING/PARKING BRAKE MUST BE FULLY APPLIED, THE ENGINE STOPPED AND THE VEHICLE SECURED TO PREVENT MOVEMENT.**

- 20 To lower wheels using a jacking strut, proceed as follows:
  - 20.1 Check that all personnel are clear of vehicle.
  - 20.2 Start engine and select lowest forward gear range.
  - 20.3 Release parking brake and ease vehicle forward until jacking strut is free of load.
  - 20.4 Stop vehicle, apply parking brake and stop engine.
  - 20.5 Remove jacking strut.

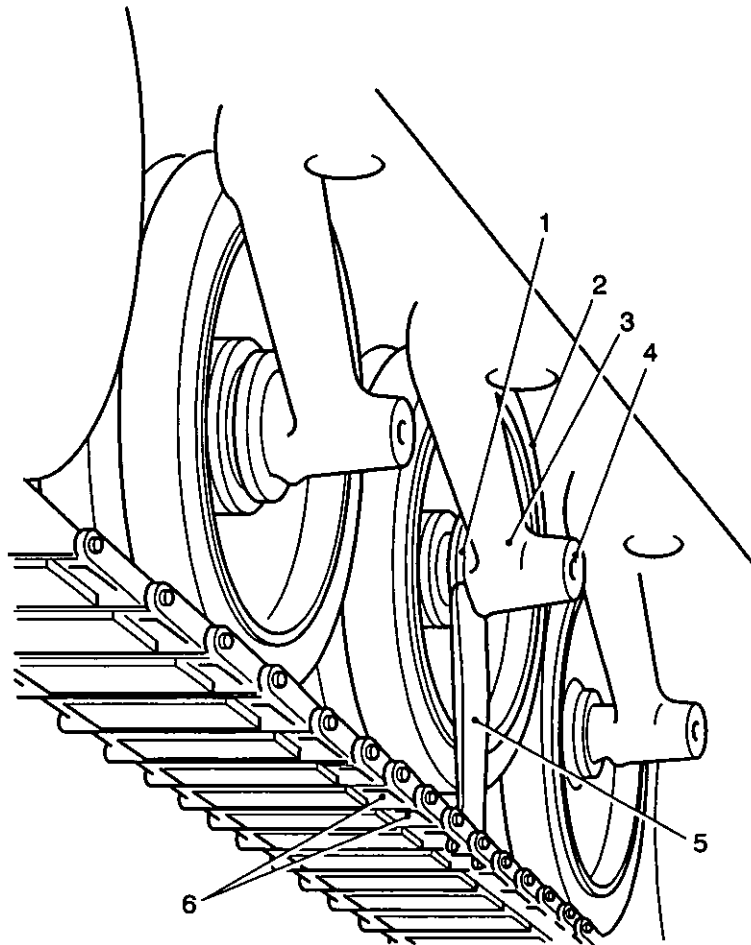

432/076

- 1 Axle distance piece
- 2 Road wheel
- 3 Axle arm

- 4 Mandrel socket
- 5 Jacking strut
- 6 Sprocket tooth slots

Fig 6 Jacking strut

### Torsion bars

21 Check for broken torsion bars by viewing the road wheel tyre bulge where it contacts the track. If the torsion bar has broken, the wheel will not be sharing the vehicle load and a bulge will not occur. Lifting the arm by means of a crowbar will confirm the breakage.

### TRACK ADJUSTERS

22 Adjustment of the tension of each track is achieved by moving the idler wheels rearward (to increase tension) and forward (to decrease tension) by use of a hydraulic ram.

23 Track tension is altered by the track adjuster (Fig 7). The adjusting movement is effected by a hydraulic ram. The ram is extended by pumping grease through a nipple (15) in the head and retracted by unscrewing a relief screw (14), which is adjacent to the nipple. A lug welded to the rear of the stub axle extension contacts the adjuster bracket and acts as a limit stop when the full effective travel of the ram plunger has been reached.



**Checking the track adjuster**

24 Check the tightness of the tensioner bracket bolts and the track adjusting wheel nuts (AESP 2350-T-251-601 refers). If for any reason the nuts securing the adjusting wheel discs have been slackened, they must be tested for tightness and tightened if necessary. They should then be tightened daily for the next three days that the vehicle is operated.

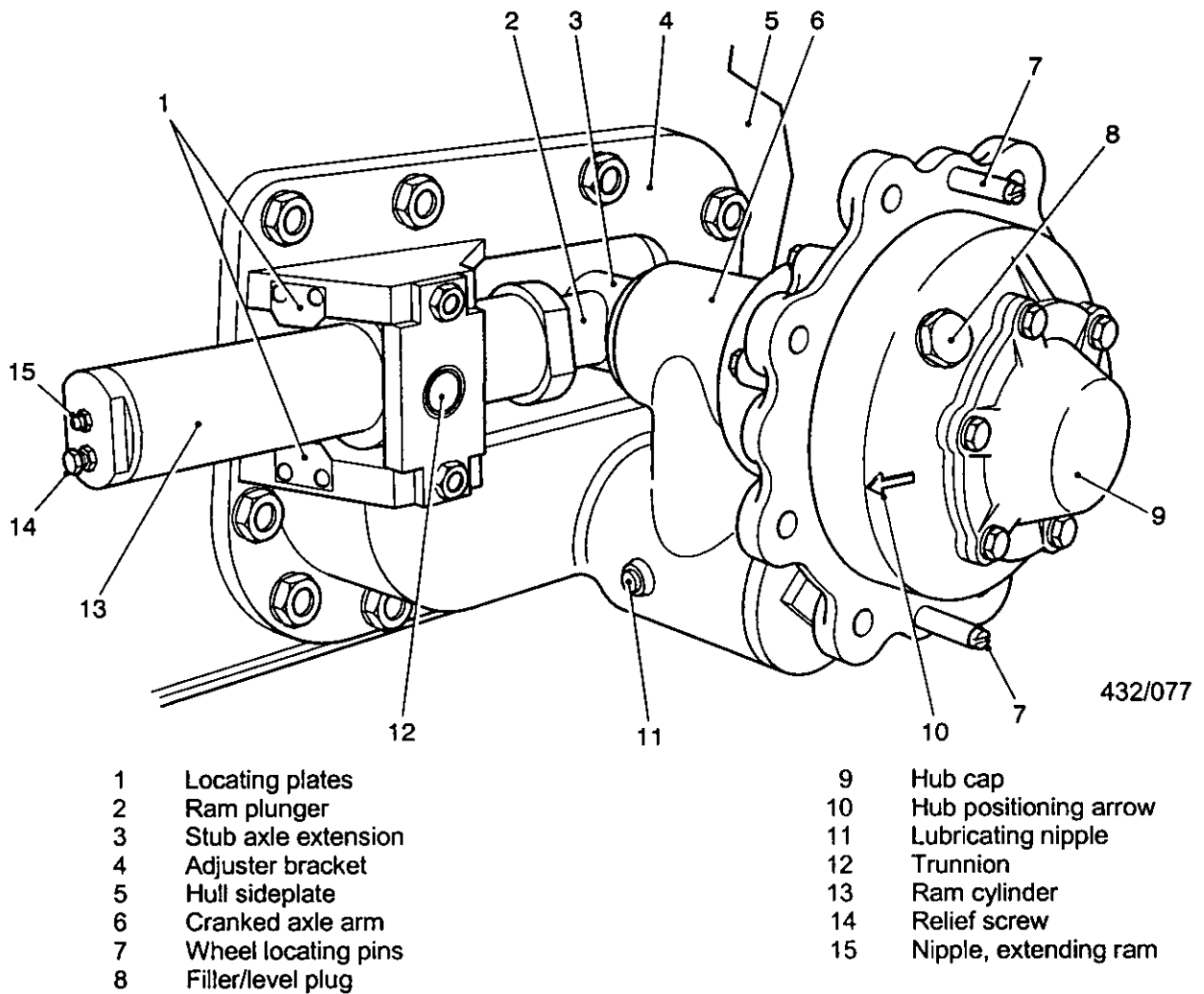

Fig 7 Track adjuster

**Lubrication of the track adjusters**

25 One lubrication nipple (Fig 7(11)) is provided on each track adjuster pivot arm. When injecting grease into the pivot arm bearing do not use excessive force as the end faces are sealed. For lubrication of the track adjuster wheel hubs, see Para 14.

**GUIDE ROLLERS**

26 The double rubber tyre guide roller assemblies are fitted with a lubrication nipple (Fig 5(1)) on the hubcap. Grease should be injected until it exudes from the labyrinth cover at the inner face of the roller.

**TRACKS**

27 New tracks each comprise ninety, rubber padded links connected by hexagonal pins (Fig 8(6)). A polyurethane washer (7) is fitted under each pad to provide a firm but resilient seating. When re-padding, the washers should be re-used, unless cracked or broken, as they are designed to last the life of the track. Four spare links are carried in the vehicle stowage. Each link weighs approximately 8.3 Kg (18.3 lbs).

28 There must be the same number of links in each track. When removing tracks always renew sprockets if they are at all worn. The tracks must be fitted so that the spud (2) face of each link is trailing as the links pass over the sprockets. Replace tracks in pairs.

29 When driving on a straight course and the vehicle does not maintain a reasonably straight course, the cause is probably in the tracks (see Para 31 to 35). If in any doubt report to REME.

30 The sprocket rings are bolted in pairs onto the sprocket hubs of the final drives. Maximum permitted sprocket tooth wear markings are incorporated in the sprocket rings. It is acceptable for the sprocket rings to be rotated (in pairs) to extend life.

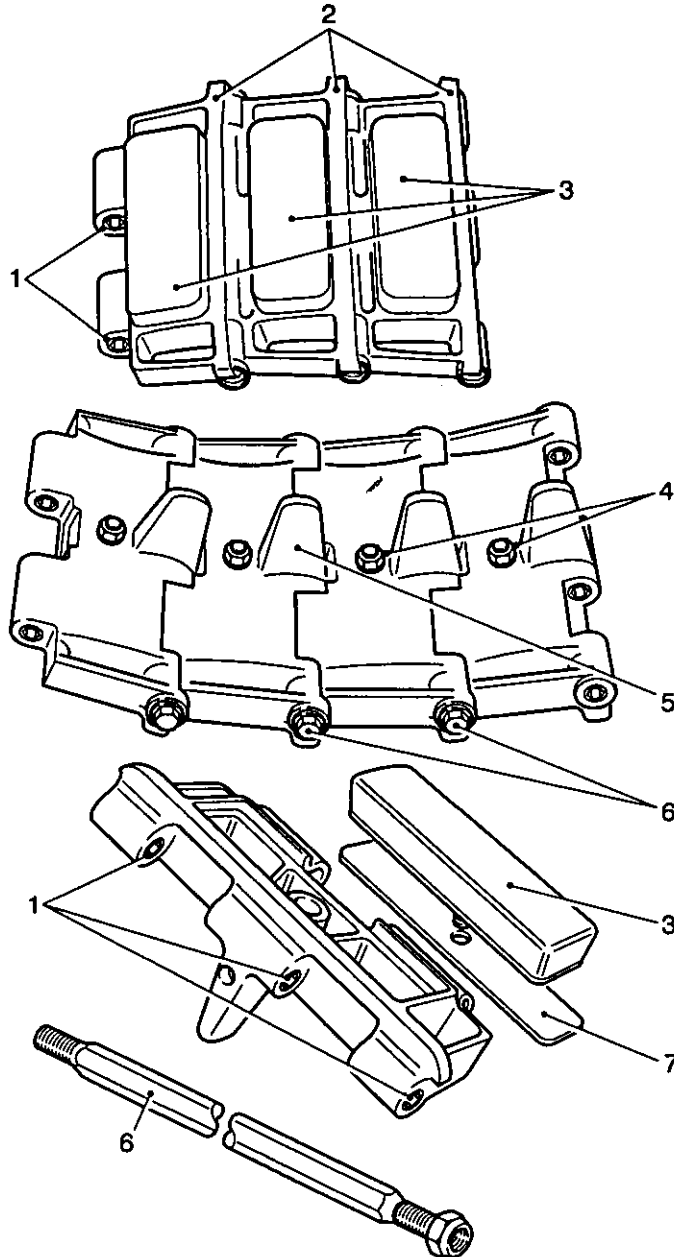

432/078

- |   |  |   |                     |
|---|--|---|---------------------|
| 1 | Hexagon sleeves in rubber bushes             | 5 | Guide horns         |
| 2 | Spuds  | 6 | Link pins           |
| 3 | Rubber pads                                  | 7 | Polyurethane washer |
| 4 | Nuts and spring washers securing rubber pads |   |                     |

Fig 8 Rubber bushed and padded track

**Track inspection****WARNINGS**

(1) **SAFETY HAZARD. PERSONNEL INSPECTING TRACKS MUST REMAIN IN SIGHT OF THE COMMANDER. THEY ARE NOT TO STAND BEHIND THE VEHICLE WHILST IT IS IN MOTION. THEY ARE TO RETAIN VISUAL CONTACT WITH THE COMMANDER. THEY ARE NOT TO MAKE PHYSICAL CONTACT WITH ANY PART OF THE TRACK AND RUNNING GEAR WHILST THE VEHICLE IS IN MOTION.**

(2) **SAFETY HAZARD. THE COMMANDER MUST ALWAYS REMAIN IN SIGHT OF THE DRIVER AND MAINTAIN VISUAL CONTACT WITH PERSONNEL INSPECTING THE TRACKS. SHOULD ANY OF THE PERSONNEL DISAPPEAR FROM VIEW OR NOT RESPOND TO HIS COMMANDS HE IS TO IMMEDIATELY INSTRUCT THE DRIVER TO HALT THE VEHICLE.**

(3) **SAFETY HAZARD. THE DRIVER MUST HALT THE VEHICLE IF THE COMMANDER GOES OUT OF HIS SIGHT.**

(4) **SAFETY HAZARD. IT IS NOT SAFE PRACTICE TO HAVE BOTH TRACKS REMOVED AT THE SAME TIME, AS NO VEHICLE BRAKING IS AVAILABLE. IF TWO TRACK REMOVALS IS UNAVOIDABLE SECURE THE VEHICLE BY CHOCKING THE ROAD WHEELS BEFORE SPLITTING THE SECOND TRACK.**

(5) **SAFETY HAZARD. BEFORE PERSONNEL ARE ALLOWED UNDER THE VEHICLE, THE STEERING/PARKING BRAKE MUST BE FULLY APPLIED, THE ENGINE STOPPED AND THE VEHICLE SECURED TO PREVENT MOVEMENT.**

31 Ensure that the path of the vehicle is clear of obstructions and stand at the front of the vehicle facing the inside of one track. Signal the driver to reverse.

32 While the vehicle is being driven in reverse inspect the track:

32.1 For faulty or bent pins.

32.2 Check that the pads are secure and there is sufficient rubber to prevent the metal link contacting the ground. Torn or missing pads must be replaced, when replacing pads ensure that the polyurethane washer is fitted under each pad.

32.3 Ensure bushes do not protrude from the lugs. Check for collapsed or badly worn bushes, this is indicated by links sagging on the top run of the track.

32.4 Check for any signs of cracking on the links. Cracks normally appear at either side of the lugs.

33 Stop the vehicle. Stand at the side of the vehicle facing the outside of the track.

34 Signal the driver to drive slowly forward and inspect the outside of the track similarly to inspecting the inside of the track. Halt the vehicle.

**NOTE**

On new tracks, the pads are liable, after supporting the vehicle weight, to bed down and loosen. It is necessary therefore, that during the first 80 km (50 miles) running of a new track, the stud nuts securing the pads should be checked frequently for tightness.

35 Repeat operations in Para 31 to 34 for the other track.

**Track tension**

36 The tension of the tracks must be set to 25.4 to 38.1 mm (1 to 1-1/2 in.) sag (clearance) midway between the guide rollers with no slack under the sprocket or track adjusting wheel. The adjustment must be carried out so that there is the correct clearance when the vehicle is fully laden. Both tracks must be adjusted to the same tension.

### Checking the track tension

37 The procedure to check the track tension is as follows:

- 37.1 With the vehicle on hard level ground, slacken the six nuts securing the rear track guard and lift the guard off by allowing the clearance holes to pass over the nuts and washers.
- 37.2 Slacken the five nuts securing the front guard and similarly remove.
- 37.3 Slacken the securing bolt on either side of the rear track shield and raise the shield.
- 37.4 Start the engine and engage reverse gear. Release the steering/parking lever for the track that is to be checked.
- 37.5 Gently accelerate the engine and immediately the vehicle starts to turn, decelerate to stop the drive, re-apply the brake/steering lever, and engage the parking control to prevent the sprocket being turned forward by the track resettling. Stop the engine.
- 37.6 Check for clearance mid-way between the two guide rollers. This can be measured by using a length of string stretched taut along the track.
- 37.7 If necessary, adjust the track tension (Para 38 and 39) and repeat Sub-Paras 37.4 – 37.6.
- 37.8 Repeat for the other track.
- 37.9 Replace the track shield and track guards in the reverse sequence and secure

#### NOTE

Before replacing the guards, check that the studs are serviceable and that the guards are not damaged or distorted.

### Adjusting the track tension

38 If the track is to be tightened, inject grease with a grease gun through the nipple (Fig 7(15)) in the head of the ram cylinder (13) until the tension is correct.

39 If the track is to be slackened, unscrew the relief screw (14) until grease escapes through the drilling in the screw. Re-tighten the screw securely when the track has slackened sufficiently. If necessary, gather any slack from under the track adjusting wheel and recheck.

### **Breaking and removing a track**

#### **WARNINGS**

**(1) PERSONAL INJURY. IT IS ESSENTIAL THAT THE TRACK IS REMOVED UNDER CONTROL USING TRACK REMOVAL TOOLS**

**(2) SAFETY HAZARD. IT IS NOT SAFE PRACTICE TO HAVE BOTH TRACKS REMOVED AT THE SAME TIME, AS NO VEHICLE BRAKING IS AVAILABLE. IF TWO TRACK REMOVALS IS UNAVOIDABLE SECURE THE VEHICLE BY CHOCKING THE ROAD WHEELS BEFORE SPLITTING THE SECOND TRACK.**

**(3) SAFETY HAZARD. BEFORE PERSONNEL ARE ALLOWED UNDER THE VEHICLE, THE STEERING/PARKING BRAKE MUST BE FULLY APPLIED, THE ENGINE STOPPED AND THE VEHICLE SECURED TO PREVENT MOVEMENT.**

#### **CAUTION**

**EQUIPMENT DAMAGE. Vehicle damage may occur if the track is not restrained during the removal procedure.**

40 The procedure for breaking and removing a track is as follows:

40.1 Tracks are normally broken between the sprocket and first road wheel as this position facilitates the operation.

40.2 Drive the vehicle onto hard level ground, bringing the track pin to be removed into position between the sprocket and first road wheel. Apply the steering/brake levers and apply the parking controls. Stop the engine.

40.3 Remove the track guards and raise the end shield.

40.4 Fit the track-fitting tool (AESP 2350-T-250-741 refers) onto the protruding end of the dowel pin securing each guide roller spindle.

40.5 Fully slacken the track (para 38 refers) by means of the adjuster (Fig 7(14)). Fit the track clamps (AESP 2350-T-250-741 refers) on the inside of the track into the sprocket holes in the track links either side of where the track is to be 'broken'. Tighten the screws to relieve the tensional load from the track pins held in the clamps. Continue tightening until an angle of 10 deg is obtained between the links on the pin to be removed. At this angle, the torsional load on the bushes will be relieved. Remove the nut from the outer end of the track pin. Drive out the track pin using the drive punch (AESP 2350-T-250-741 refers). Take care not to burr the end of the track pin. Slacken and remove the clamps then lower the end of the track to the ground.

40.6 Fit the track lifting and pulling adaptor (AESP 2350-T-250-741 refers) to the end of the top run of the track and attach a rope. Start the engine, engage reverse gear, apply the brake on the same side as the broken track and drive the vehicle as slowly as possible, steadying the end of the track with the rope. Before the track is clear of the adjusting wheel, stop the vehicle, apply the steering/brake lever, and stop the engine. Pull the track clear while controlling it with the rope, if necessary taking a bight around the sprocket.

40.7 Lay out the track and remove the adaptor and rope.

#### **Moving the vehicle with one track removed**

41 Start the engine and put the gear control lever to 1-2 range or reverse as required. Release the brakes, gently accelerate the engine to take up the drive and apply either steering lever. If the steering brake on the same side as the 'broken' track is applied, the vehicle will move quickly, if the other brake is applied, the vehicle will move slowly.

#### **Replacing a track**

42 The procedure for replacing a track is as follows:

42.1 Before fitting a track, lay it out beneath the vehicle and check for bend. If the bend exceeds 100 mm (4 in.) over the track length, the faulty link(s) must be replaced.

42.2 Fit the track lifting and pulling adaptor and rope (AESP 2350-T-250-741 refers) to the end of the track, pass the rope over the support rollers and take one turn round the sprocket hub. A member of the crew will be required to keep the rope taut. (See Fig 10)

42.3 Start the engine and put the gear control lever in the 1-2 range. Release the steering/brake levers and gently accelerate the engine to take up the drive. Apply the steering/brake lever to the broken track so that the vehicle will move forward slowly. Using the hub as a windlass, draw the track over the support rollers and into engagement with the sprocket.

42.4 Stop the vehicle and remove the rope from the hub.

42.5 Continue to drive the vehicle forward, working the slack of the track over the sprockets until the ends of the track are close enough together to fit the track clamps. Stop the vehicle and switch OFF the engine. Support the ends of the track with a crowbar and fit the clamps (AESP 2350-T-250-741 refers).

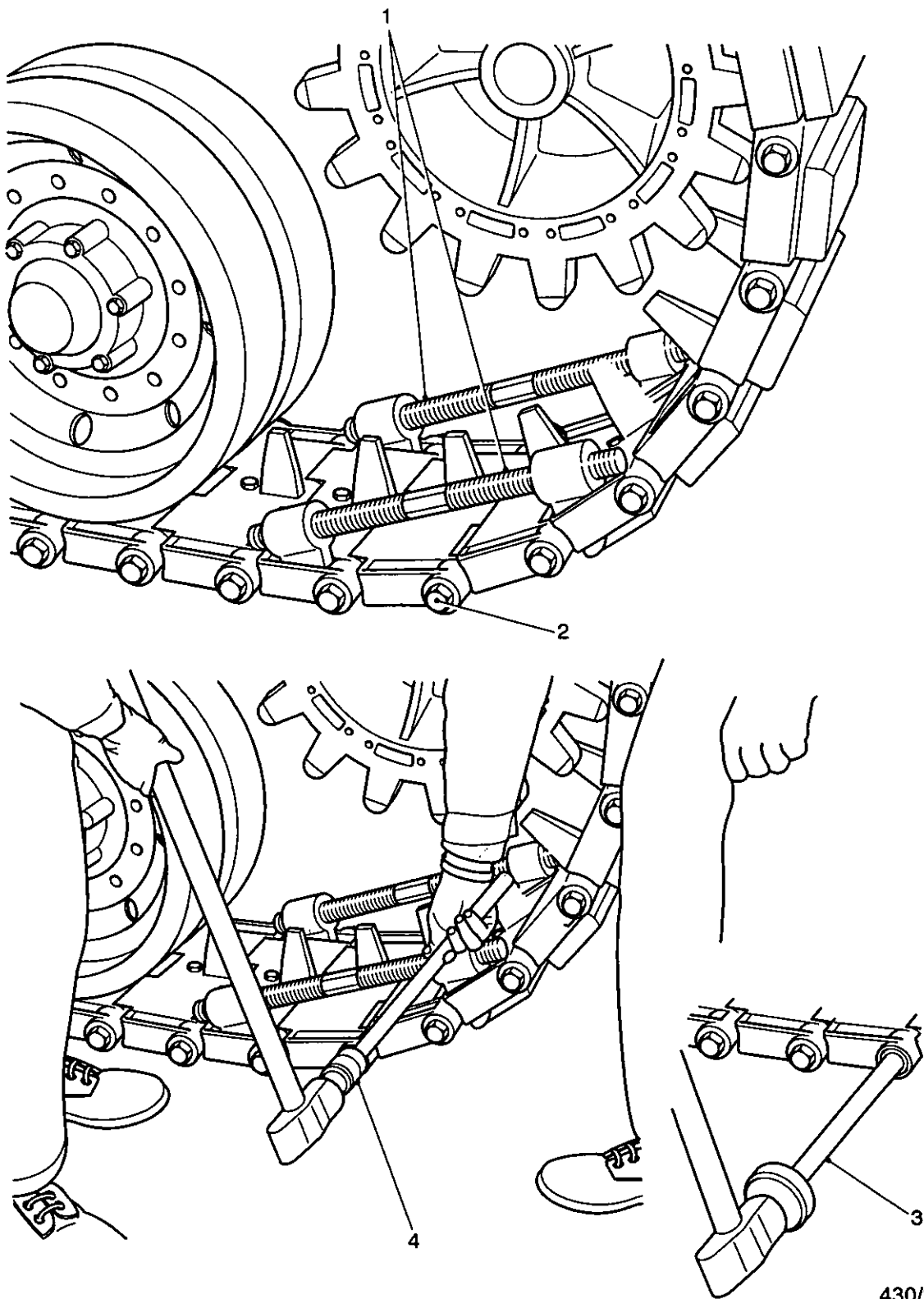

430/20053

- |   |   |   |                    |
|---|---|---|--------------------|
| 1 | Track clamps in position                                  | 3 | Drive pin          |
| 2 | Track pin - to be removed (splitting) or fitted (joining) | 4 | Sleeve/handle tool |

Fig 9 Track splitting/joining

42.6 Tighten the clamps taking care that as the lugs and recesses of the links come into mesh the ends of the bushes are not damaged, and then continue tightening until the hexagonal liners in the bushes align. This can be checked by sighting through.

42.7 Fit a lead pin to one end of a track pin and a striker to the other.

42.8 Insert the greased pin ensuring that it is pushed in as far as the second lug before tapping home carefully with a hammer. Remove the lead pin and striker, fit a nut to each end of the pin, and then remove the track clamps. Remove the track-fitting tool.

42.9 Adjust the track to the correct tension (Para 38 refers).

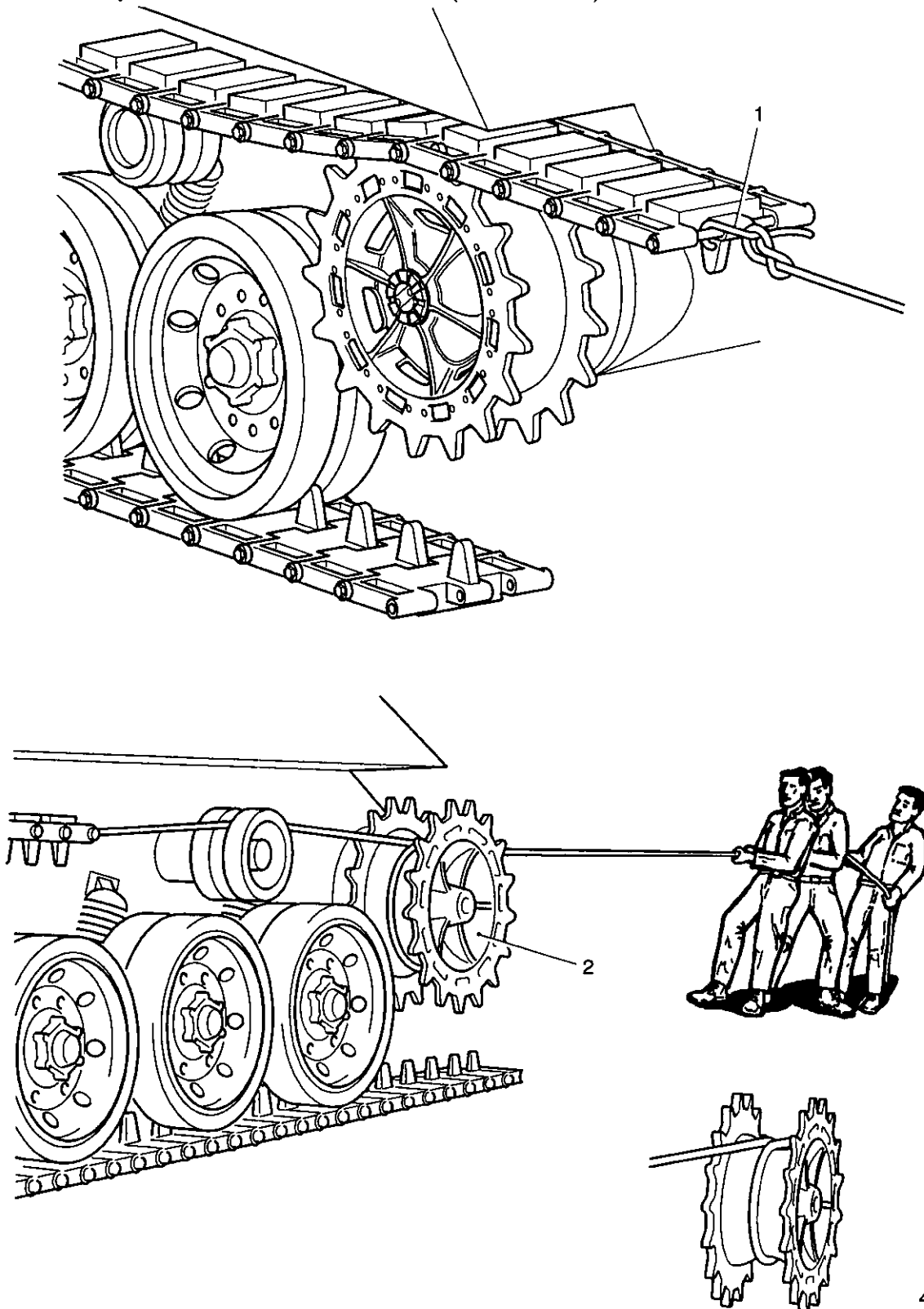

432/492

- 1 Track lifting and pulling tool used to attach track rope to track broken end
- 2 Using sprocket as capstan for track rope

Fig 10 Attaching track rope and using sprocket as capstan

## FINAL DRIVE SPROCKET RINGS

43 The final drive sprocket rings are fitted with recessed faces on lugs facing away from the sprocket hub so that the flat on the bolt head is held by the lip of the recess. One lug of each flange of the hub has a dowel (Fig 12(1)) and one lug of the sprocket ring has a dowel hole, to ensure correct location of the sprocket rings onto the final drive sprocket hub. One tooth of the sprocket ring has a wear indicator engraved into it (Fig 11).

### Reversal, removal and refitting of sprocket rings

44 The sprocket rings will wear and provision is made to increase their life by removing and reversing the sprockets to the final drive. To remove, reverse, refit or renew the sprockets rings proceed as follows:

44.1 Remove the track on the side of the vehicle that the sprockets are to be removed or reversed. Para 40 refers.

44.2 Remove the nuts, Fig 12(3), spring washers (4) and bolts (6) securing the sprockets to the sprocket hub and remove the sprockets.

44.3 If the sprockets are to be reversed, refit the sprockets so that the outer sprocket is fitted to the inside and the inside sprocket is fitted to the outside as shown in Fig 11. Ensure that the dowel is located into the sprocket. This ensures that the sprockets are aligned.

44.4 If the sprockets are to be renewed, discard the old sprockets and replace with new ones, fitting them as described in Para 44.3.

44.5 Refit the nuts, bolts and washers removed in Para 44.2, replacing those that are damaged or worn and tighten to a torque of 41 Nm (30 lbf ft).

44.6 Refit the track as described in Para 42 and repeat the procedure to replace the sprockets on the opposite side.

### NOTE

The sprocket bolts must be tested for tightness daily after reversal or renewal of the sprocket rings.



**Inspection**

- 45 The sprocket rings are to be reversed if the wear on the front of the sprocket teeth reaches the wear indicators (Fig 11(2)).
- 46 The sprocket rings are to be condemned and renewed if one or more of the following criteria are met:
- 46.1 Sprocket tooth wear excessively exceeds the wear indicators on one side.
  - 46.2 Sprocket tooth wear has reached the wear indicator on both sides.
  - 46.3 Sprocket rings show signs of flaking or surface cracks.
  - 46.4 One or more of the sprocket ring securing holes are elongated.

**NOTE**

If any sprocket ring fails the inspection criteria both pairs must be renewed.

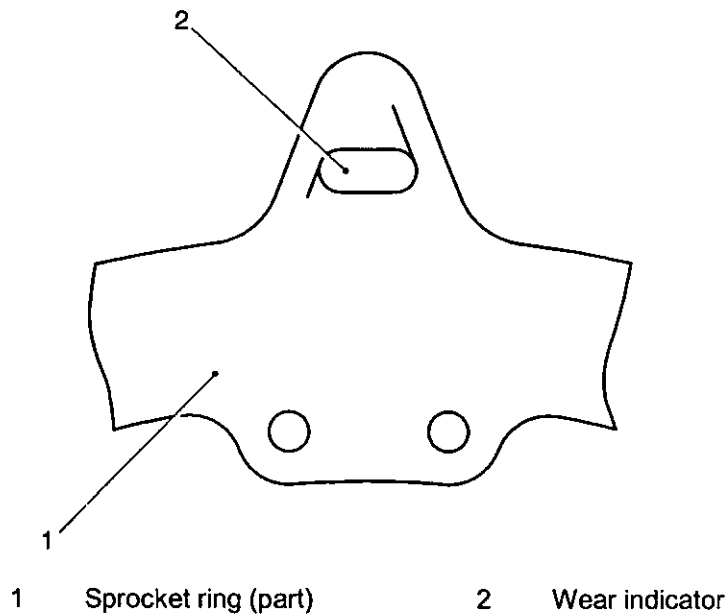

430/20179

Fig 11 Sprocket ring wear indicator

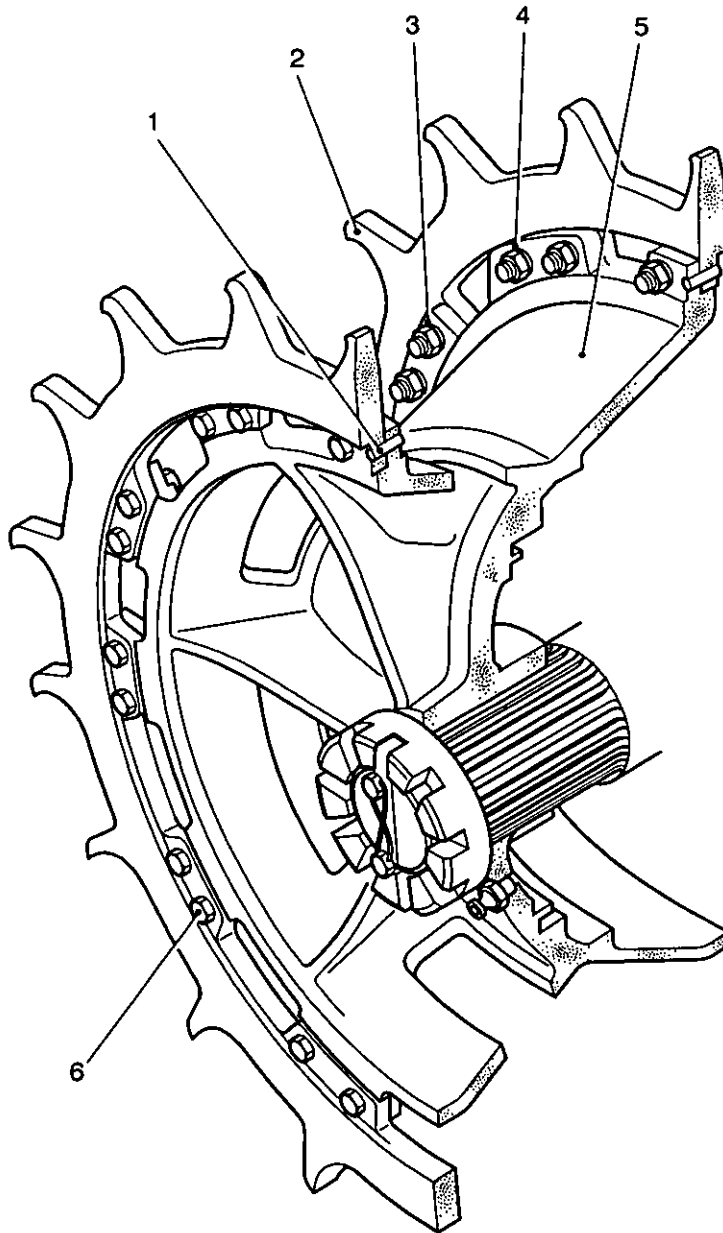

430/20073

- 1 Dowel
- 2 Worn sprocket ring
- 3 Nut

- 4 Spring washer
- 5 Final drive hub
- 6 Bolt

Fig 12 Final drive sprockets

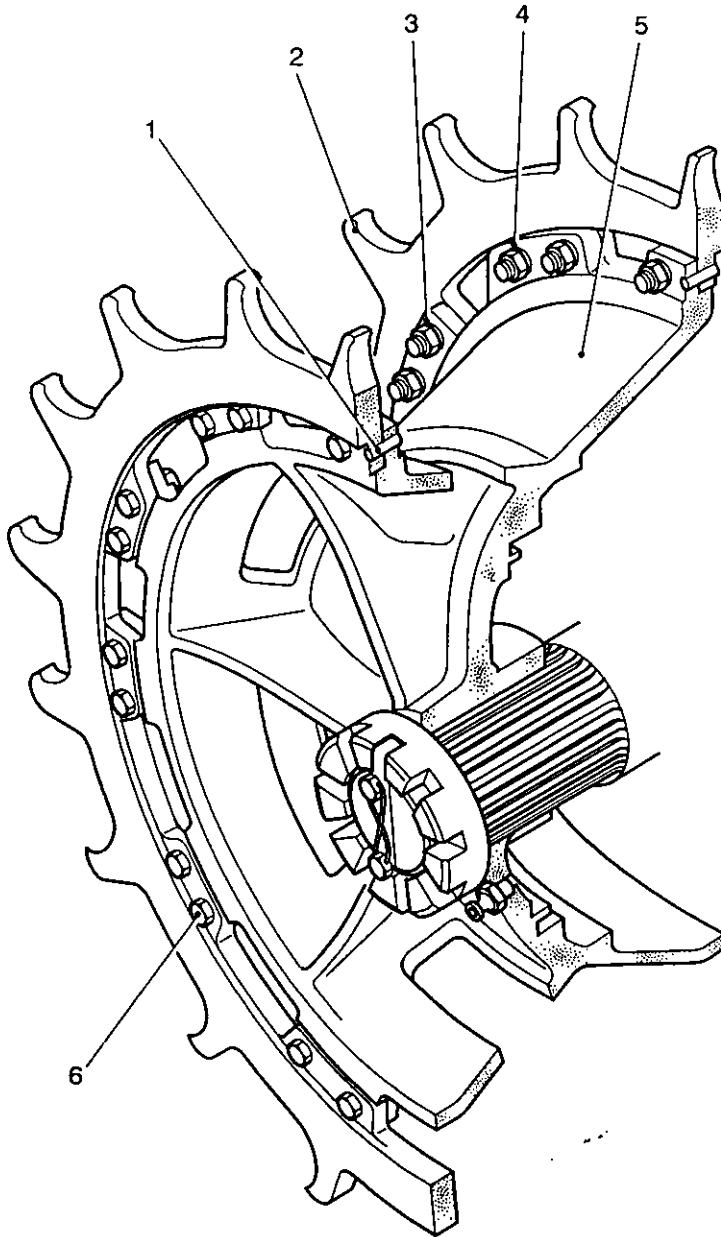

430/20074

- |   |                               |   |                 |
|---|-------------------------------|---|-----------------|
| 1 | Dowel                         | 4 | Spring washer   |
| 2 | Worn sprocket ring (reversed) | 5 | Final drive hub |
| 3 | Nut                           | 6 | Bolt            |

Fig 13 Final drive sprockets (reversed)

**CHAPTER 2-5**  
**VENTILATION CONTROL SYSTEM**  
**CONTENTS**

Para

- 1 Ventilation system
- 3 Operating the ventilation system
- Maintenance
- 10 Filter check
- 11 Cleaning the filter
- 13 Cleaning the moisture trap

Fig

Page

1	Distribution panel No. 6 Mk 1 .....	2
2	Ventilation fan controls and radio distribution box (Mk 2 vehicles) .....	3
3	Ventilation filters (Mk 2 vehicles) .....	4
4	Ventilation filters (Mk 2/1 vehicles) .....	5
5	Moisture trap .....	6

**VENTILATION SYSTEM**

1 Clean air is drawn into the vehicle through two pairs of filter elements by a fan and is then circulated through ducting fitted with diffusers and flexible nozzles.

2 The outer filters (particulate) contain paper elements, which extract the solid particles from air passing through; the inner filters (anti-vapour) are no longer available, therefore a dummy insert is utilised to ensure correct location of the outer particulate filter.

**Operating the ventilation system**

3 The system can be used when the vehicle is open or closed down.

4 Switch on the fan circuit at the distribution panel No. 6 Mk 1 (Fig 1(1)). The battery master switch (2) must be 'ON' for the fan to operate.

5 Set the fan control (Fig 2(1)) at the slowest speed that will maintain the internal air pressure at a reading of +3 on the gauge (Fig 5(5)). At this pressure the relief valve in the roof plate to the left rear of the mortar hatch will be at the point of lifting off its seating.

6 Adjust the diffusers for crew comfort.

7 In warm humid atmospheres, the diffusers can be directed to pass air over the personnel to suit conditions.

8 When the ambient temperature is high, the diffusers can be reversed to produce a direct stream of air.

9 Adjust the flexible nozzles to suit requirements.

**NOTE**

The battery supply is only sufficient to run the fan at maximum speed for approximately 2½ hours; it is therefore, essential to conserve the supply as much as possible. Always switch 'OFF' at the distribution panel No. 6, Mk1, when the fan is not being used.

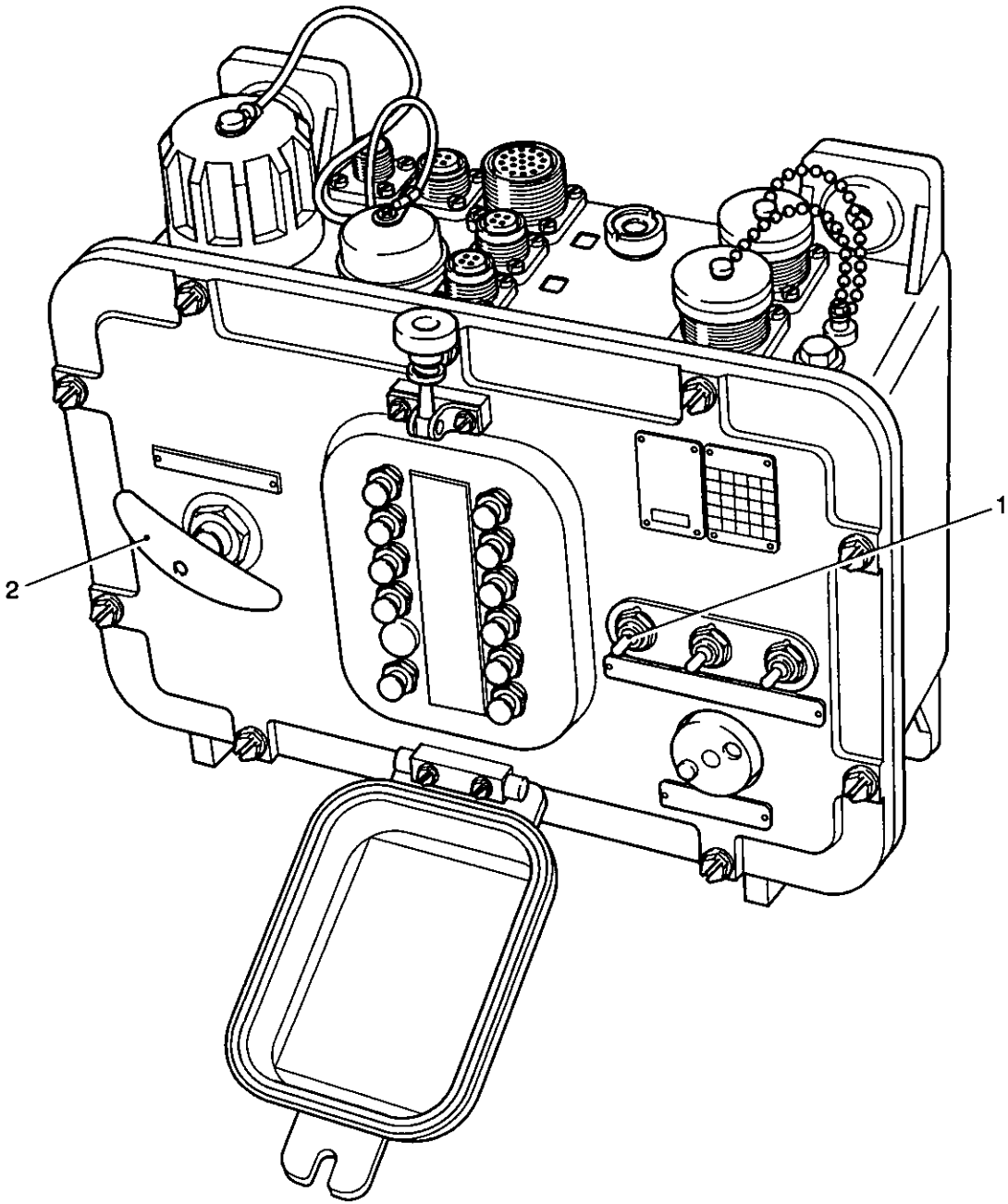

432/039

1 Fan switch

2 Battery master switch

Fig 1 Distribution panel No. 6 Mk 1

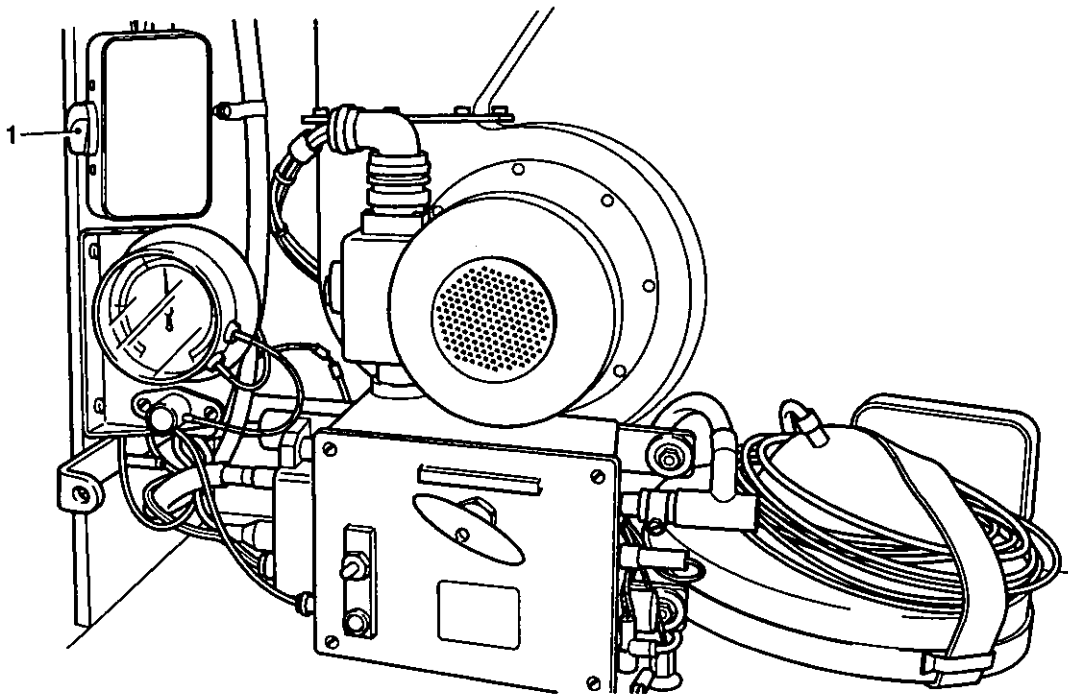

430/20124

1 Fan control

Fig 2 Ventilation fan controls and radio distribution box (Mk 2 vehicles)

## MAINTENANCE

### Filter check

10 To check the condition of the particulate filters, press the test button and the gauge vacuum reading will give an indication of the amount of dust built up on the elements. Should the reading on the gauge exceed -5 inches WG, it is necessary to remove the filters for cleaning.

### Cleaning the filter

11 The particulate filters may be cleaned three times only by shaking to remove the dust build up. After this, replacement filters must be obtained and installed.

12 To remove and replace the particulate filters for cleaning, proceed as follows:

12.1 Switch 'OFF' the fan circuit at the Distribution Panel No. 6, Mk 1.

12.2 Mk 2 vehicles - Release the locking clamps (Fig 3(3) and (15)) and open the filter housing access covers.

12.3 Mk 2/1 vehicles - Remove the spanner (Fig 4(4)) stowed in a spring clip (5) and bracket on the hull side plate, then release the clamping bolts (3) and open the filter housing door.

12.4 Remove the spanner (Fig 3(12) or Fig 4(8)) stowed in a spring clip on the side of the filter housing and unscrew each clamping bolt (Fig 3(7) or Fig 4(12)) in turn to release the clamp bars (Fig 3(14) or Fig 4(11)).

12.5 Withdraw the two filter holders (13) with the particulate filters inside them.

12.6 Slide the filter from each holder, keeping the filter square with the holder. Clean the elements by shaking until as much dust as possible has been removed. If the elements have already been cleaned three times by this method, discard them and fit replacement filters.

12.7 If anti vapour filters are fitted, remove the gaskets, which separate the two filters.

12.8 Withdraw the anti vapour element filters using the rings provided and discard them. New filters must be fitted.

12.9 Replace the filters and the filter holders in the reverse order in which they are removed. Locating strips welded to the filter frames ensure that the filters are correctly installed. Tighten the clamping bolts only sufficiently to make an effective seal without straining the holder.

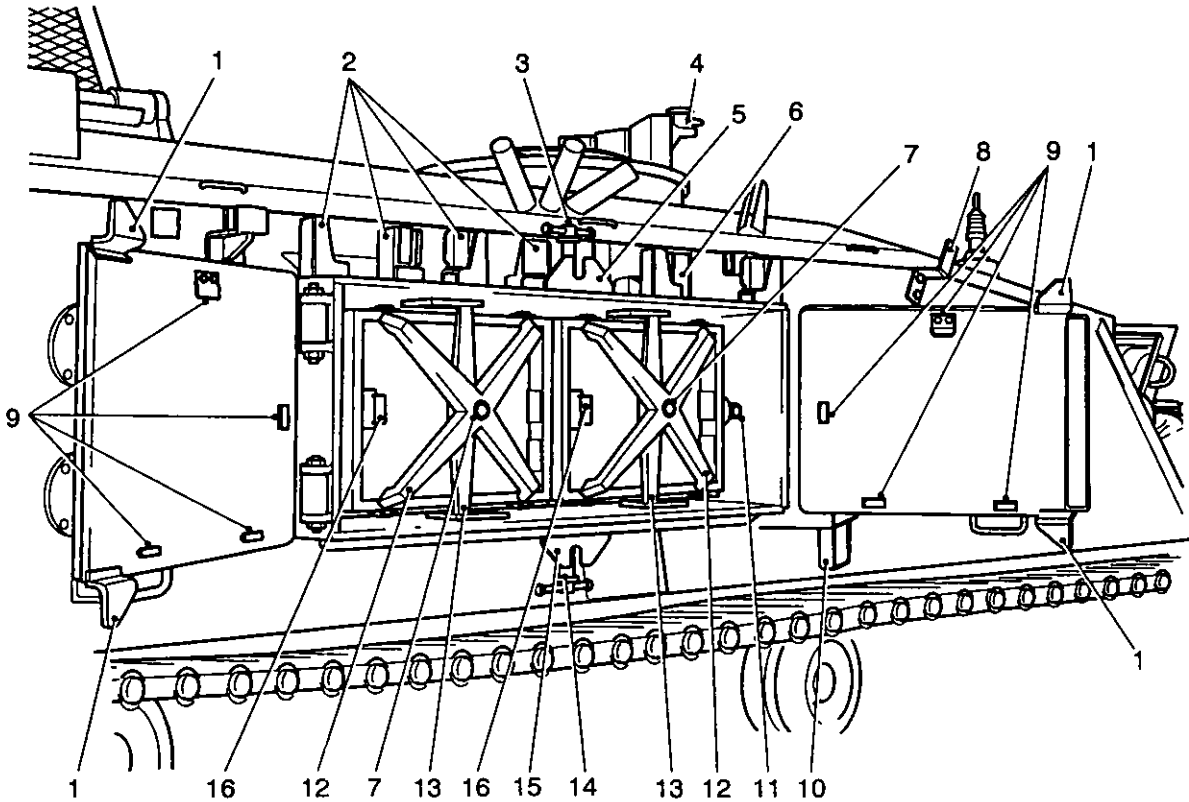

430/20125

1	Door clamping lugs	9	Blanking plate stowage clips
2	Track link stowage brackets	10	Mounting stirrup
3	Locking clamp	11	Spanner
4	MG mounting brackets	12	Filter holder
5	Locking clamp brackets	13	Clamp bar
6	Track link stowage brackets	14	Locking clamp
7	Clamping bolt	15	Locking clamp brackets
8	Tow rope stowage bracket	16	Blanking plates

Fig 3 Ventilation filters (Mk 2 vehicles)

12.10 For Mk 2 vehicles, stow the filter-housing spanner, close and lock the access plate.

12.11 For Mk 2/1 vehicles, stow the filter-housing spanner, close, secure the housing door, and stow the housing door spanner.

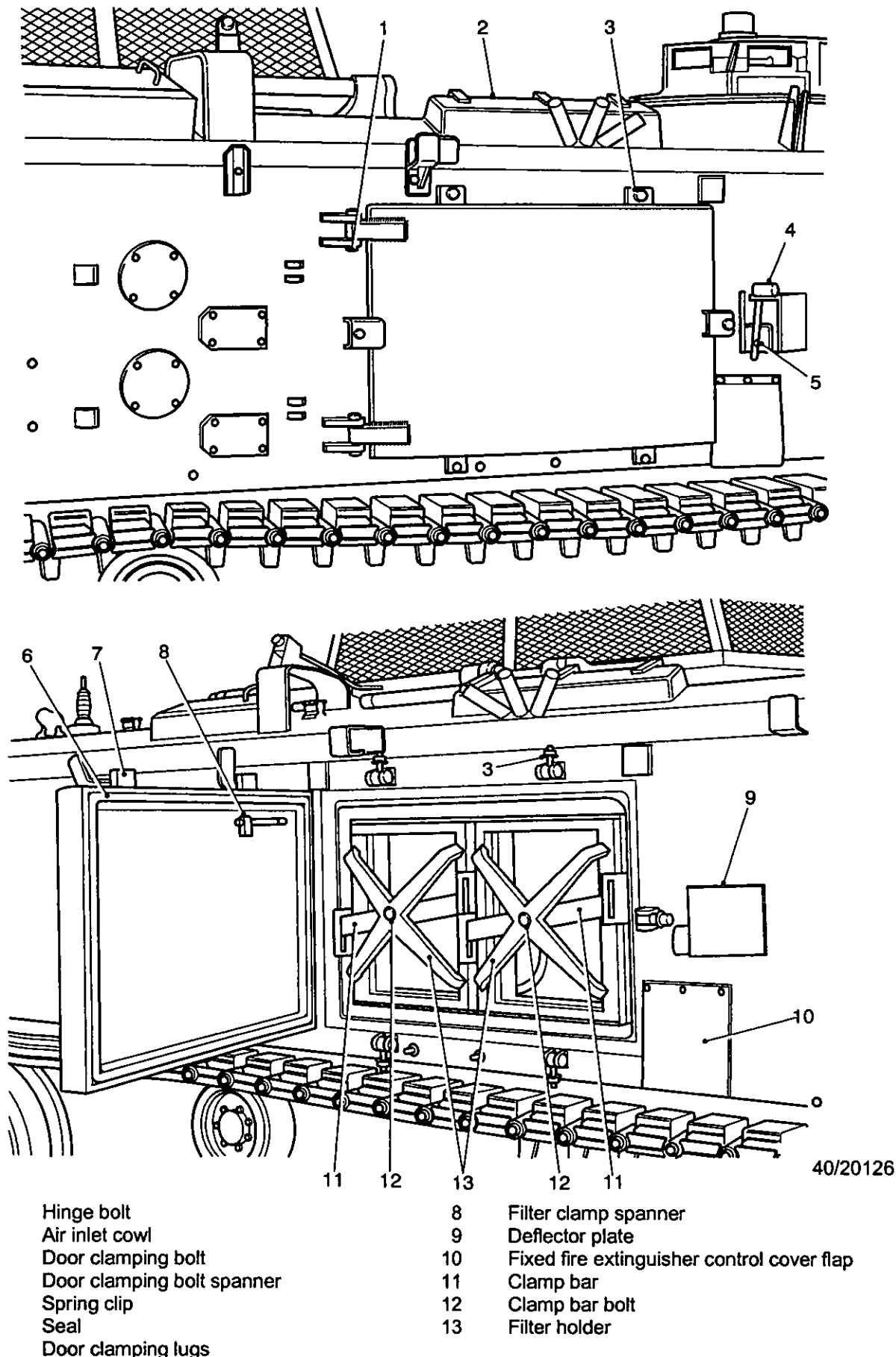

- |   |                            |    |  |
|---|----------------------------|----|--|
| 1 | Hinge bolt                 | 8  | Filter clamp spanner                       |
| 2 | Air inlet cowl             | 9  | Deflector plate                            |
| 3 | Door clamping bolt         | 10 | Fixed fire extinguisher control cover flap |
| 4 | Door clamping bolt spanner | 11 | Clamp bar                                  |
| 5 | Spring clip                | 12 | Clamp bar bolt                             |
| 6 | Seal                       | 13 | Filter holder                              |
| 7 | Door clamping lugs         |    |  |

Fig 4 Ventilation filters (Mk 2/1 vehicles)



**Cleaning the moisture trap**

13 With the fan switched 'OFF', unscrew the bowl clamping ring (Fig 5(2)) and lower bowl (3); slide the sleeve (4) from the filter screen.

14 Wash the bowl in warm soapy water only, rinse, and dry thoroughly.

**NOTE**

DO NOT use thinners or similar solvents to wash this bowl, as these will destroy the plastic material from which it is constructed.

15 Reassemble. Ensure that the sealing washer is correctly positioned.

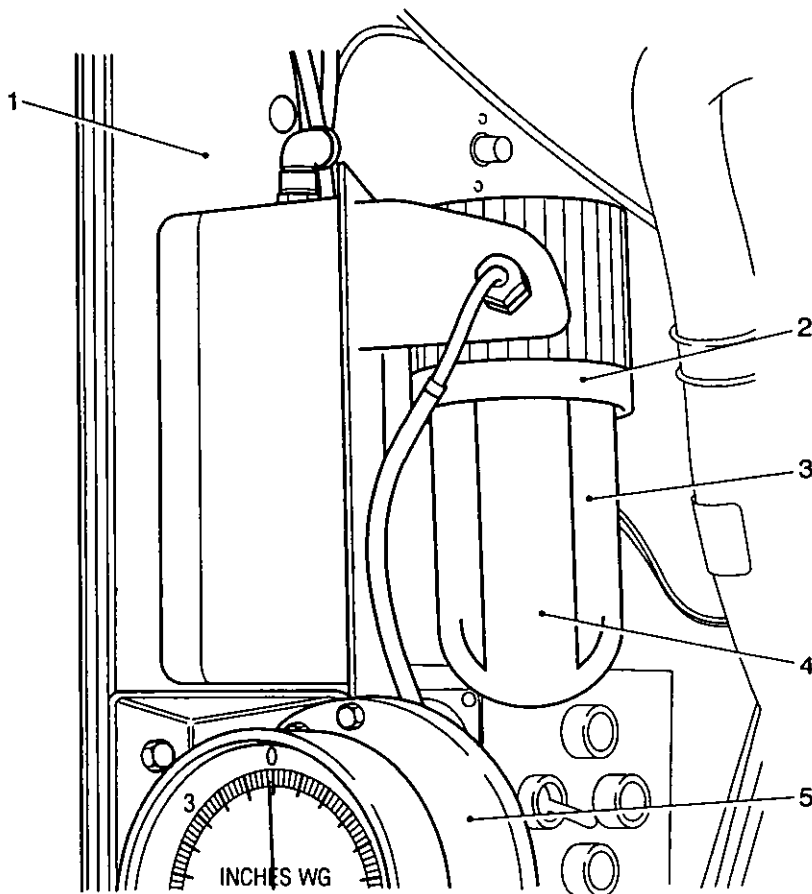

430/20127

1 Transverse bulkhead  
2 Clamping ring  
3 Bowl

4 Sleeve  
5 Pressure/vacuum gauge

Fig 5 Moisture trap

CHAPTER 2-6  
ELECTRICAL SYSTEM  
CONTENTS

Para	
1	General (WARNING)
3	Circuit breakers
4	Lamps
5	Distribution panel No. 6 Mk 1
6	Resetting a circuit breaker
7	Radio distribution box (Mk 2 and Mk 2/1 vehicles)
8	Changing a fuse (WARNING)
10	Warning light – radio distribution box
12	Changing a lamp
13	Instrument panel
14	Instrument panel lights
16	Changing an instrument panel lamp
17	Driver's switchboard
18	External lighting switchboard (WARNING)
20	Dipswitch
21	Warning lights – oil pressure and main indicator generator
22	Warning lights – turn-light and main beam
25	Auxiliary junction box
26	Changing a fuse
27	Horn push button
28	Smoke grenade dischargers
29	Fire alarm system
30	Wiper switch
31	Distribution link box warning light
32	Changing a lamp
33	Alternators (WARNING)(CAUTIONS)
34	Charging the batteries with the vehicle stationary (CAUTION) Batteries
36	General (WARNING)(CAUTION)
40	Maintenance free batteries
44	Cleaning and checking maintenance free batteries (WARNINGS)
45	To remove a battery from the vehicle (WARNINGS)
46	Refitting
47	Testing
48	Battery lifting tool
49	Inspection light sockets
50	Interior lights
54	Spotlight
58	Changing a lamp
59	Amber rotating beacon
61	External lighting socket
62	Boiling vessel sockets
64	Boiling vessel (CAUTION)
69	Boiling (WARNING)(CAUTIONS)
70	Making beverages (CAUTION)
71	Heating compositions - decanted
72	Heating compositions - undecanted (WARNING)
73	Frying (WARNINGS)(CAUTION) Boiling vessel servicing (WARNING)
76	Cleaning inner food container
77	Cleaning water compartment

(continued)

## CONTENTS (continued)

Para		
78	Drain tap	
79	Lid	
	Headlight	
80	Changing a lamp (WARNING)	
81	Side, turn, tail/stop and fire warning lights	
83	Changing a lamp	
84	Registration plate light and convoy light	
85	Registration plate light	
86	Changing a registration plate lamp	
87	Convoy light	
88	Changing a convoy lamp	
89	Servicing the rear door contacts	
	Rectifier unit	
90	Changing a main fuse	
	Maintenance	
91	Suppression of electrical interference to radio services	
<b>Table</b>		<b>Page</b>
1	Circuit breakers.....	3
2	Lamps .....	4
3	Distribution panel No. 6 Mk 1 .....	5
4	Radio distribution box (Mk 2 and Mk 2/1 vehicles).....	9
5	Instrument panel .....	11
6	Driver's switchboard .....	13
7	External lighting switch combinations .....	15
8	Auxiliary junction box.....	16
9	Times for water to boil .....	28
<b>Fig</b>		<b>Page</b>
1	Driver's controls and instruments .....	4
2	Distribution panel No. 6 Mk 1 (if fitted) .....	7
3	Radio distribution box (Mk 2 vehicles).....	9
4	Radio distribution box (Mk 2/1 vehicles).....	10
5	Instrument panel .....	12
6	Driver's switchboard .....	14
7	Auxiliary junction box .....	17
8	Gear range selector .....	18
9	Radio distribution box fuse (Mk 2 vehicles).....	19
10	Driver's compartment.....	21
11	Ventilation batteries (Maintenance free type).....	22
12	Radio batteries (Maintenance free type) .....	23
13	Rear of vehicle.....	26
14	Boiling vessel .....	29
15	Drain tap .....	31
16	Headlight.....	32
17	Sidelight .....	33
18	Registration plate light .....	33
19	Convoy light .....	34
20	Rear door connections .....	35

**GENERAL**

1 The vehicle is fitted with three sets of batteries, automotive, ventilation, and radio, which are charged by the rectified output of two alternators.

2 The outputs of the two alternators are connected in parallel to a rectified unit and the rectified output is connected to the vehicle wiring and is indicated by an ammeter on the driver's instrument panel. The field circuit of each alternator is connected to transistor type regulators housed in separate control panels which control the rectified voltage at 28.5 V over an engine speed range of 600 rev/min (1,750 rev/min alternator speed), up to its governed speed.

**WARNING**

**PERSONNEL HAZARD. THE VOLTAGES USED ON SOME OF THE EQUIPMENT ON THE VEHICLE, EG RADIOS, CAN BE LETHAL. DO NOT TAMPER WITH THESE EQUIPMENTS OR ATTEMPT ANY REPAIR OR ADJUSTMENT WITH THE BATTERY SWITCHES ON.**

**Circuit breakers**

3 Table 2 details the ratings of the Circuit Breakers (CB's).

**TABLE 1 CIRCUIT BREAKERS**

Circuits (1)	Fuses (2)			
	Location (a)	Identification (b)	Type and rating (c)	
Circuit controlled by fuses F1, F3 and F5 in auxiliary junction box and smoke dischargers.	Distribution panel No. 6 Mk 1	A	15 A	
Horn, 12 point socket, Lights: head, side, tail, convoy, registration plate, turn stop, IR driving.		B	15 A	
Fire alarm warning lights.		C	10 A	
Distribution panel inspection light sockets.		D	10 A	
		E	(Not fitted)	
External lighting sockets.		F	25 A	
Ventilating fan motor relay.		Fan switch (CBR FV436, FV439)	G	5 A
Heater circuit		Fan switch (NBC FV436, FV439)	H	35 A
Circuits controlled by eng switch			K	15 A
Fuel pump, injection pump stop solenoid, battery analogue.			L	15 A
Engine coolant thermometer, fuel gauge, gearbox oil thermometer, oil pressure switch, alternator (GEN) warning light, starter switch, alternator boost and instrument panel lights fuse.		M	10 A	

**Lamps**

4 Table 2 details the ratings and type of the lamps fitted to the vehicle.

**TABLE 2 LAMPS**

Light (1)	Volts (2)	Watts (3)	Type (4)
Head, Flood	26	50/50	British pre-focus
Tail/stop	28	30/7	Small Bayonet Cap (SBC) index pins
Side, Registration plate, Convoy interior	26	6	Small Centre Contact (SCC)
Warning and Instrument panel	28	1.1 (0.04A)	Midget flange
IR driving	26	100/100	European cap
Turn and Fire warning	24	24	SCC

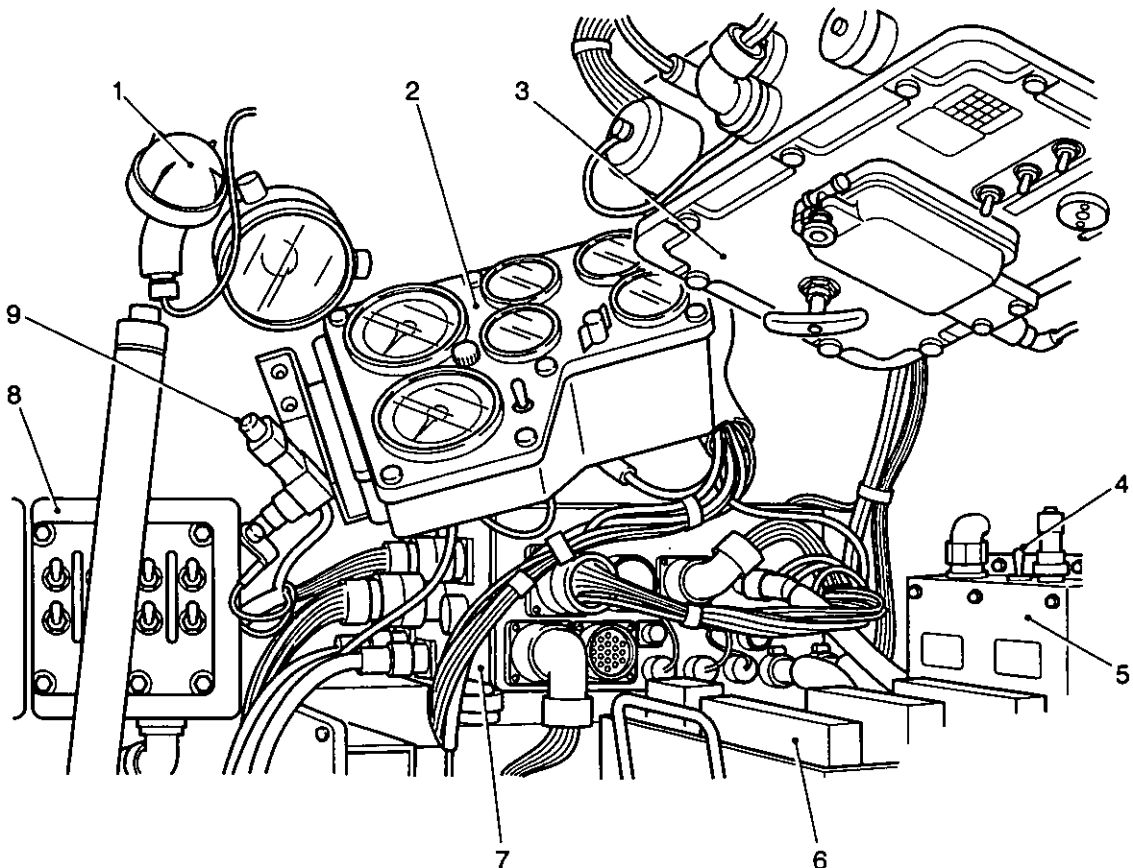

430/20128

- |   |                                  |   |                       |
|---|----------------------------------|---|-----------------------|
| 1 | Fire warning light               | 6 | Automotive batteries  |
| 2 | Instrument panel                 | 7 | Distribution link box |
| 3 | Distribution panel               | 8 | Driver's switchboard  |
| 4 | Firewire control box test switch | 9 | Horn push             |
| 5 | Firewire control box             |   |                       |

Fig 1 Driver's controls and instruments

**Distribution panel No. 6 Mk 1.**

5 The distribution panel No. 6 Mk 1 is equipped with circuit breakers, Table 3 details the functions of the controls on the distribution panel No. 6 Mk 1; the number in brackets in the control/instrument column (2) refers to the key identification of Fig 2

**TABLE 3 DISTRIBUTION PANEL NO. 6 MK 1.**

Serial (1)	Control/instrument (2)	Description (3)	Identification (if any) (4)
1	Inter vehicle starting socket (1)	An Inter vehicle starting socket, covered by a protective cap when not in use.	
2	Inspection light socket (2)	An inspection light socket, covered by a protective cap when not in use.	
3	Desiccator (3)		
4	Boiling vessel sockets (4)	Two sockets for the connection of the boiling vessel harness.	
5	Waterproof test plug (5)		
6	Fan switch (6)	Controls the operation of the ventilating fan. The switch must always be set in the OFF position when the fan is not in use.	FAN
7	Heater switch (7)	Controls the operation of the heater unit if fitted.	HEATER
8	External lighting switch (8)	Controls the four way socket on the power tool assembly at the rear of the vehicle. The socket is provided for external lighting, the switch must always be set in the OFF position when not in use.	EXT LIGHTING
9	Battery switch position indicator (9)	Indicates position of battery switch	
10	Battery indicator switch (10)	A two-position switch, having a lockable cover. Switch must be set to position 2 for normal use and position 3 when the vehicle is converted to the Ambulance role.	BATTERIES
11	Locking screw (11)	Captive screw for locking the battery switch in position.	
12	Cover (12)	Circuit Breaker cover and Circuit Breaker identity label.	(continued)

TABLE 3 DISTRIBUTION PANEL NO. 6 MK 1 (continued).

Serial (1)	Control/instrument (2)	Description (3)	Identification (if any) (4)
13	Circuit breaker (13)	5A C B to protect the ventilating fan relay circuit. (CBR on FV436, FV439)	G
14	Circuit breaker (14)	35A C B to protect the heater unit circuit. (NBC on FV436, FV439)	H
15	Circuit breaker (15)	15A CB to protect the fire alarm circuit.	J
16	Circuit breaker (16)	15A CB to protect circuits protected by the engine switch.	K
17	Circuit breaker (17)	15A CB to protect the fuel pump, injection stops solenoid and battery analogue circuits.	L
18	Circuit breaker (18)	10A CB to protect the engine coolant thermometer, gearbox oil thermometer, oil pressure switch, alternator (GEN) warning light, starter switch, alternator boost and instrument panel lights circuits.	M
19	Circuit breaker (19)	25A CB to protect the external lighting sockets circuit.	F
20	(20)	Not in use.	E
21	Circuit breaker (21)	10A CB to protect the distribution panel inspection light socket circuit.	D
22	Circuit breaker (22)	10A CB to protect the fire alarm warning lights circuit.	C
23	Circuit breaker (23)	15A CB to protect the horn, head lights, side lights, tail lights, mini-fascine lighting, convoy light, registration light, turn lights, stop lights and IR driving lights circuits.	B
24	Circuit breaker (24)	15A CB to protect the smoke grenade discharger and circuits controlled by fuses F1, F3 and F5 in the auxiliary junction box circuits.	A
25	Battery switch (25)	A semi rotary switch. Turn handle clockwise for the ON position and counter clockwise for the OFF position. In the OFF position the automotive and ventilation battery positive terminals are isolated from all circuits except the fire warning horn.	BATTERY

~~UNRESTRICTED~~

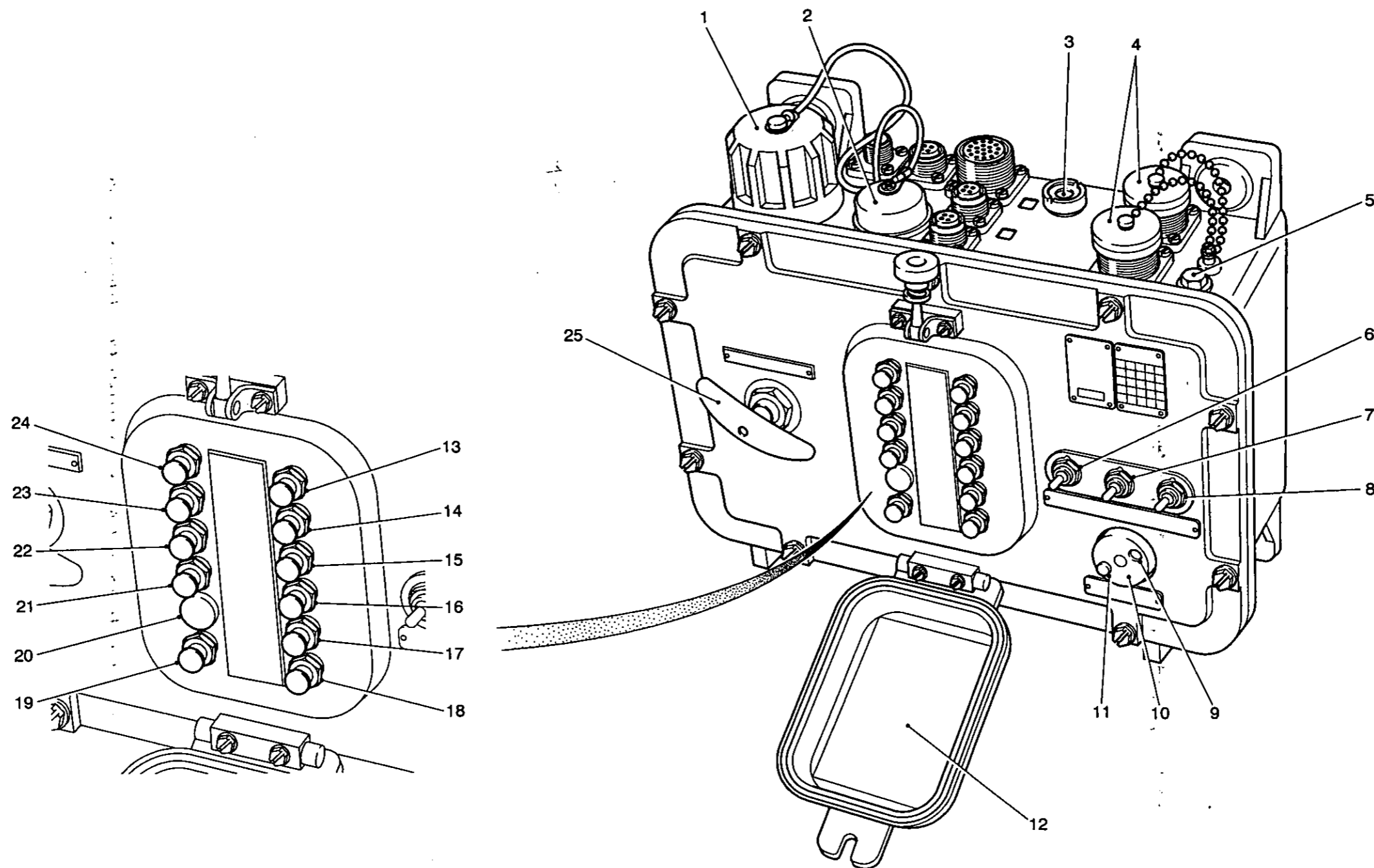

- 1 Inter-vehicle starting socket
- 2 Inspection light socket cap
- 3 Desiccator
- 4 Boiling vessel socket caps
- 5 Waterproof test plug
- 6 Fan switch (CBR Switch on FV439)
- 7 Heater switch (NBC Switch on FV439)
- 8 External lighting switch
- 9 Battery switch position indicator

- 10 Battery indicator switch
- 11 Locking screw
- 12 Cover
- 13 Circuit breaker (G)
- 14 Circuit breaker (H)
- 15 Circuit breaker (J)
- 16 Circuit breaker (K)
- 17 Circuit breaker (L)

- 18 Circuit breaker (M)
- 19 Circuit breaker (F)
- 20 Circuit breaker (E)
- 21 Circuit breaker (D)
- 22 Circuit breaker (C)
- 23 Circuit breaker (B)
- 24 Circuit breaker (A)
- 25 Battery switch

Fig 2 Distribution panel No. 6 Mk1 (if fitted)

432/431

~~UNRESTRICTED~~



Resetting a circuit breaker

6 The procedure for resetting a circuit breaker in the distribution panel No. 6 Mk 1 is as follows:

6.1 Switch off the relevant faulty circuit.

6.2 Release the circuit breaker cover (Fig 2(12)), which is secured by a hinged bolt with a knurled nut.

6.3 Press the button of the appropriate circuit breaker to reset the circuit breaker. A white collar on the stem of the button shows when the circuit breaker is in the tripped position.

6.4 Switch on the appropriate circuit. If the circuit breaker trips again report to REME.

6.5 Replace the cover.

6.6 To manually open a circuit breaker pull the bottom of the circuit breaker until the pressure of an integral mechanical latch is overcome.

Radio distribution box (Mk 2 and Mk 2/1 vehicles)

7 Mounted on the sill at the front right hand corner of the personnel compartment, below the ventilating fan motor. Table 6 details the functions of the controls on the radio distribution box, the number in brackets in the control/instrument column (2) refers to the key identification of Fig 3 and Fig 4.

**TABLE 4 RADIO DISTRIBUTION BOX (MK 2 AND MK 2/1 VEHICLES)**

Serial (1)	Control/instrument (2)	Description (3)	Identification (if any) (4)
1	Battery switch (4)	A semi rotary switch. Turn handle clockwise for the ON position and counter clockwise for the OFF position. In the OFF position the radio battery positive terminals are isolated from all circuits except the fire warning horn.	BATTERY
2	External charge switch (5)	Provides a facility for charging external batteries. When not charging external batteries the switch must be in the OFF position, if left in the ON position the GEN warning light is inoperable.	EXT CHARGE
3	GEN warning light (6)	The lamp illuminates when the radio battery switch is in the ON position, providing the external charge switch is in the OFF position and is extinguished when charging starts. It also illuminates when external batteries are connected and the external charge switch is in the ON position and extinguishes when external charging starts.	GEN
4	Fuse cover and fuse (7)	Cover housing a 100A link type fuse.	LOAD

Changing a fuse

**WARNING**

**PERSONNEL HAZARD. THE VOLTAGES USED ON SOME OF THE EQUIPMENT ON THE VEHICLE, EG RADIOS, CAN BE LETHAL. DO NOT TAMPER WITH THESE EQUIPMENTS OR ATTEMPT ANY REPAIR OR ADJUSTMENT WITH THE BATTERY SWITCHES ON.**

- 8 The procedure for changing a fuse in the radio distribution box is as follows:
  - 8.1 Put the radio battery switch (Fig 3(4)) to OFF (see also Fig 4(4)).
  - 8.2 Remove the fuse cover (Fig 3(7)) that is secured by two captive knurled nuts.
  - 8.3 Ensure the contact surfaces of the fuse link terminals are clean and free from burns.
  - 8.4 Fit the new fuse link and replace the cover.
  - 8.5 Check the circuit and if the fuse blows again report to REME.

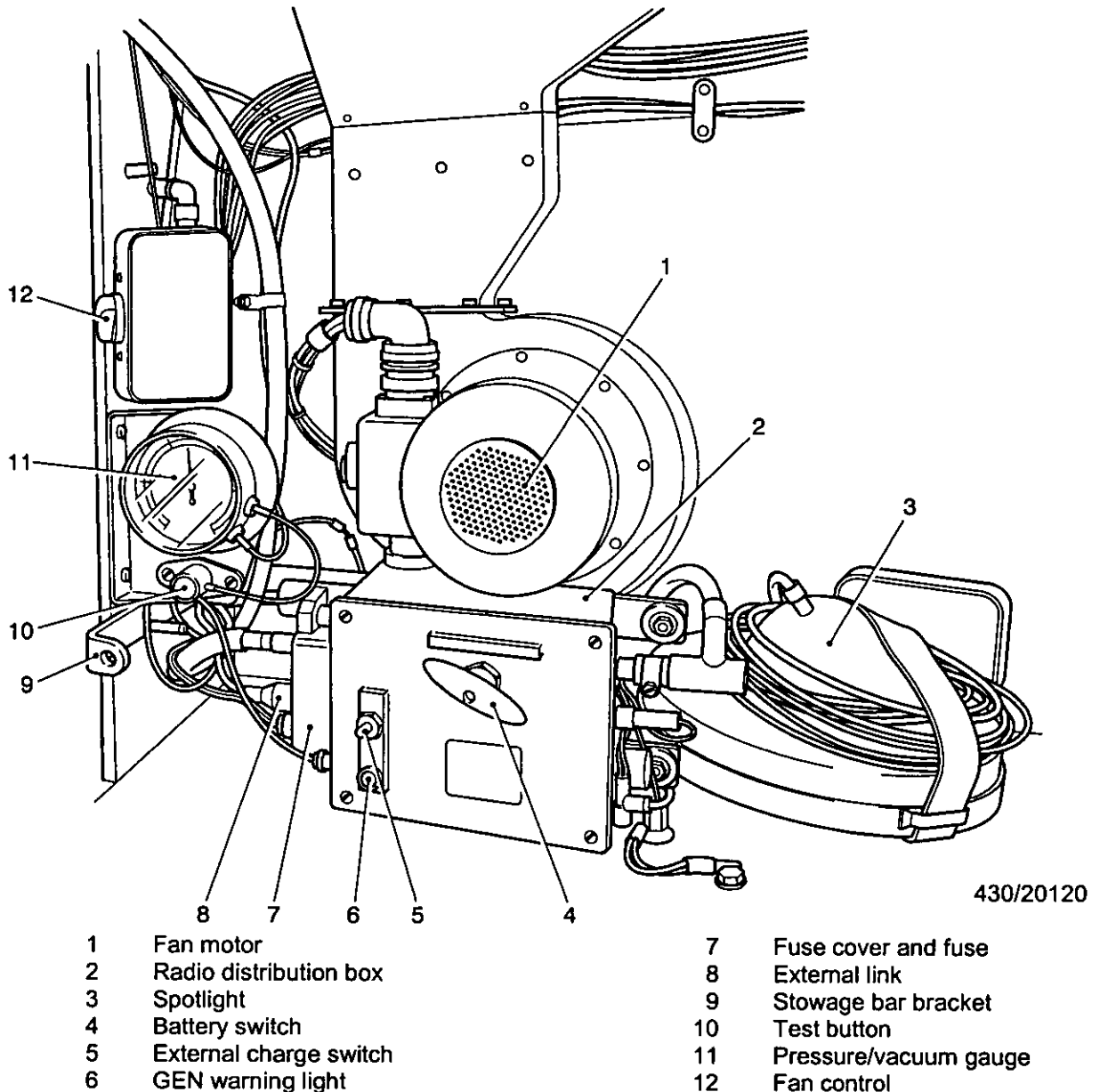
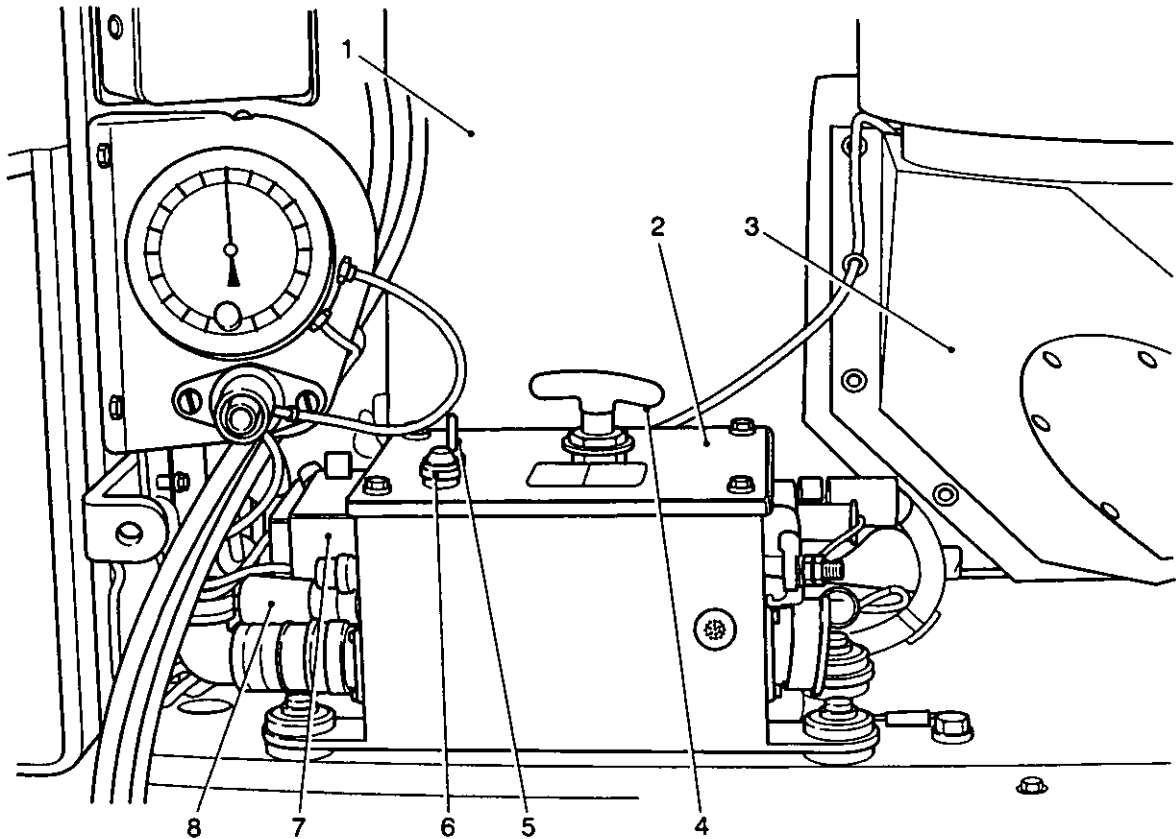

Fig 3 Radio distribution box (Mk 2 vehicles)



430/20129

1	Air conditioning filter housing	5	External charge switch
2	Radio distribution box	6	GEN warning light
3	Ducting - filter housing to fan	7	Fuse cover and fuse
4	Battery switch	8	External link

Fig 4 Radio distribution box (Mk 2/1 vehicles)

9 For functioning of the air conditioning equipment refer to Chap 2-5.

#### Warning light - radio distribution box

10 The light is similar to those fitted to the instrument panel but have a coloured lens in place of the moulded holder.

11 The radio distribution box has a Gen warning light (Fig 3(6)) or (Fig 4(6)) which has a red lens.

#### Changing a lamp

12 The radio distribution box Gen warning light is a press to test type light. The procedure for changing a press to test lamp is as follows,

- 12.1 Ensure the relevant circuit is turned OFF.
- 12.2 Unscrew the lampholder.
- 12.3 Withdraw the lamp from the holder.
- 12.4 Check that the spring-loaded centre contact is satisfactory.
- 12.5 Fit the new lamp into the holder.

12.6 Ensure the rubber washer is in place on the holder and then screw the holder in the panel.

12.7 Press to test the operation of the lamp and if it still does not function report to REME.

**Instrument panel**

13 Mounted to the right of the driver's switchboard. Table 7 details the functions of the controls on the instrument panel; the number in brackets in the control/instrument column (2) refers to the key identification of Fig 5.

**TABLE 5 INSTRUMENT PANEL**

Serial (1)	Control/instrument (2)	Description (3)	Identification (if any) (4)
1	Tachometer (1)	Indicates engine output shaft speed. Readings must be multiplied by 100.	
2	Coolant temperature gauge (3)	Indicates engine coolant temperature displayed in degrees Fahrenheit. Readings must be multiplied by 10.	
3	Fuel gauge (4)	Indicates the amount of fuel in the tanks. Graduated 0, ¼, ½, ¾ and F. Total capacity 454 litres (100 gallons imperial)	
4	Ammeter (5)	Indicates the rectified output current of the alternators.	
5	Panel light switch (6)	A combined switch and dimmer resistance controlling the eight panel lights.	DIMMER
6	Gearbox oil temperature gauge (7)	Indicates gearbox oil temperature displayed in degrees Fahrenheit. Readings must be multiplied by 10.	
7	Fuse (8)	5A cartridge fuse protecting the panel lights circuit.	5A
8	Speedometer trip reading reset knob (9)	Allows the speedometer trip reading to be reset.	RESET
9	Speedometer (10)	Indicates vehicle road speed in mph. An odometer records total vehicle mileage in the lower half of the gauge and a trip mileage indicator in the upper half.	

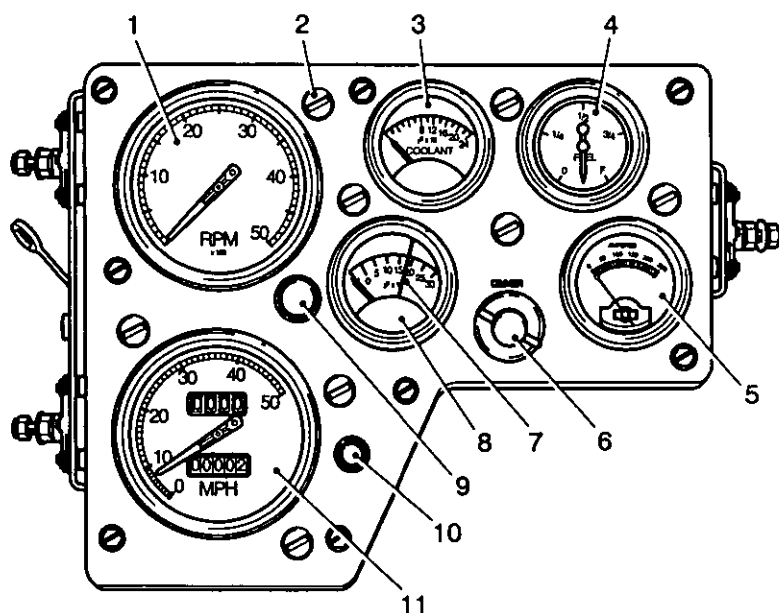

432/085

1	Tachometer	6	Panel lights switch
2	Panel light	7	Gearbox oil temperature gauge
3	Coolant temperature gauge	8	Fuse
4	Fuel gauge	9	Speedometer trip reading reset knob
5	Ammeter	10	Speedometer

Fig 5 Instrument panel

### Instrument panel lights

14 Illumination of the driver's instruments is effected by eight lights, (Fig 5(2)), having flanged midget lamps, which are push fit into holders screwed into the face of the panel.

15 The lamps are controlled by a dimmer resistance switch on the panel.

### Changing an instrument panel lamp

16 The procedure for changing an instrument panel lamp is as follows:

- 16.1 Put the instrument panel lights switch to OFF (Fig 5(6)).
- 16.2 Unscrew the lampholder.
- 16.3 Withdraw the lamp from the holder.
- 16.4 Check that the spring-loaded centre contact is satisfactory.
- 16.5 Fit the new lamp into the holder.
- 16.6 Ensure the rubber washer is in place on the holder and then screw the holder in the panel.
- 16.7 Test the operation and if it still does not function report to REME.

### Driver's switchboard

17 Located in front of the driver and containing three separate panels, the turn lights switchboard, the engine switchboard and the external lighting switchboard. Table 6 details the functions of the controls on the driver's switchboard; the number in brackets in the control/instrument column (2) refers to the key identification of Fig 6.

**TABLE 6 DRIVER'S SWITCHBOARD**

Serial (1)	Control/instrument (2)	Description (3)	Identification (if any) (4)
1	Turn light switch (1)	Contained within the turn light switchboard and controls the turn lights at the front and rear of the vehicle. To operate the rotate the switch in the direction indicated on the panel. When a trailer is connected to the vehicle and the switch is operated, the front turn lights and the trailer rear turn lights operate but the vehicle rear turn lights are inoperative.	TURN INDICATOR
2	Turn light warning Light (8)	Contained within the turn light switchboard and fitted with an amber lens, the light flashes synchronously with the turn lights. If the light does not flash when the switch is operated a turn light lamp failure is indicated.	TURN LIGHT
3	Main beam warning Light (7)	Contained within the turn light switchboard and fitted with a blue lens, the light illuminates when the main beam of the headlights are switched on.	MAIN BEAM
4	Main indicator (GEN) (2)	Contained within the engine switchboard. A press to test type light fitted with a red lens. The light illuminates when the engine switch is put to ON and extinguishes when the alternators reach the charging voltage. If the light does not illuminate when the engine switch is put to ON, press the lens, if the light does not illuminate, renew the lamp, if it does illuminate – REPORT.	GEN
5	Low oil pressure warning light (3)	Contained within the engine switchboard. A press to test type light fitted with an amber lens. The light illuminates when the engine switch is put to ON and extinguishes when the engine oil pressure reach a preset safe operating pressure. The light will illuminate if the engine oil pressure falls to a dangerously low pressure	OIL
6	Starter switch (5)	Contained within the engine switchboard. A toggle switch, spring loaded to the OFF position and protected by a spring-loaded cover to prevent accidental operation. The range selector must be in neutral and the engine switch ON before the starter motor can be operated.	START
7	External lighting switchboard (4)	Para 19 refers	

External lighting switchboard

18 Located to the right of the engine switchboard is the external lighting switchboard (Fig 6(4)) which houses four switches that control the vehicle external lighting. The bottom right hand switch is used to select NORMAL (toggle up) or BLACKOUT (toggle down) lighting. This switch has a spring-loaded cover to prevent accidental operation.

19 Table 7 details the switching combinations required to meet operational requirements. With the toggles up, the switches are in the positions designated OFF in the table and with the toggles down the positions are designated ON.

**WARNING**

**DAMAGE TO EYESIGHT. THE INFRA RED (IR) DRIVING LIGHTS ARE FITTED WITH 100 WATT LAMPS. THESE LIGHTS SHOULD NO LONGER BE USED. NEVER LOOK AT THE IR LIGHT WHEN THE FILTER IS FITTED AND THE LIGHT IS SWITCHED ON AS SERIOUS AND PERMANENT DAMAGE TO THE EYE MAY RESULT.**

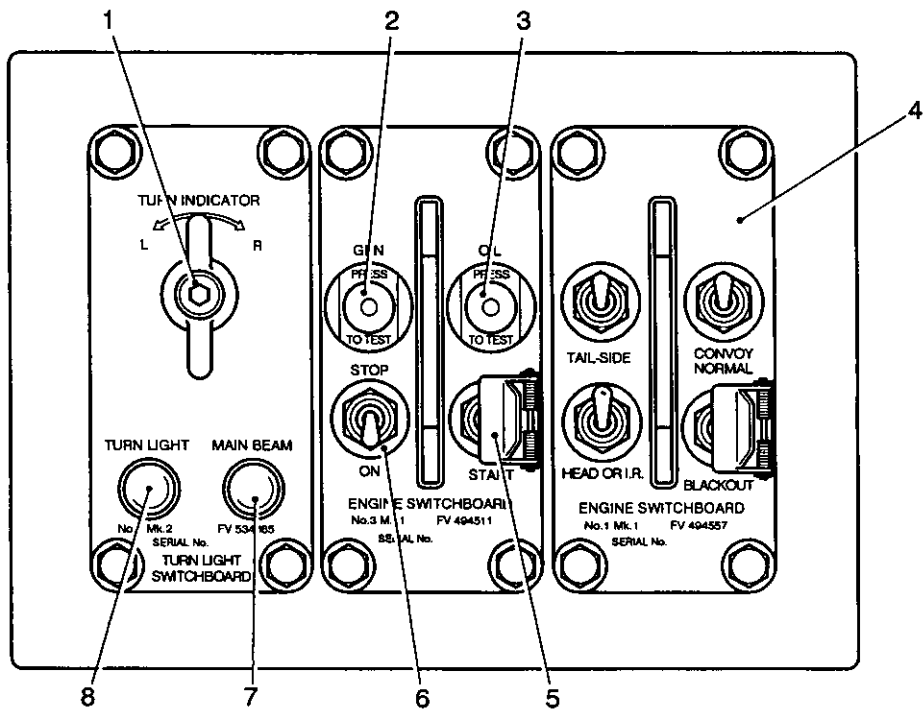

432/456

- |   |                                |   |                          |
|---|--------------------------------|---|--------------------------|
| 1 | Turn light switch              | 5 | Starter switch           |
| 2 | Main indicator (GEN)           | 6 | Engine switch            |
| 3 | Low oil pressure warning light | 7 | Main beam warning light  |
| 4 | External lighting switchboard  | 8 | Turn light warning light |

Fig 6 Driver's switchboard

**TABLE 7 EXTERNAL LIGHTING SWITCH COMBINATIONS**

SWITCH SELECTION				LIGHTS						
Blackout	Tail/side	Head/IR	Convoy	Tail	Side	Head	Reg.plate	Convoy	IR	Turn and stop
NORMAL CONDITIONS										
OFF	OFF	OFF	OFF	N/A	N/A	N/A	N/A	N/A	N/A	YES
OFF	ON	OFF	OFF	ON	ON	N/A	ON	N/A	N/A	YES
OFF	ON	ON	OFF	ON	ON	ON	ON	N/A	N/A	YES
CONVOY CONDITIONS										
OFF	OFF	OFF	OFF	N/A	N/A	N/A	N/A	ON	N/A	N/A
OFF	ON	OFF	ON	N/A	ON	N/A	N/A	ON	N/A	N/A
BLACKOUT CONDITIONS										
ON	OFF	OFF	OFF	N/A	N/A	N/A	N/A	N/A	N/A	N/A
ON	OFF	OFF	ON	N/A	N/A	N/A	N/A	ON	N/A	N/A
ON	ON	OFF	OFF	ON	N/A	N/A	N/A	N/A	N/A	N/A
ON	OFF	ON	OFF	N/A	N/A	N/A	N/A	N/A	ON	N/A
ON	ON	ON	OFF	ON	N/A	N/A	N/A	N/A	ON	N/A
ON	OFF	ON	ON	N/A	N/A	N/A	N/A	ON	ON	N/A

Dipswitch

20 The dipswitch is a foot-operated switch on the vehicle floor plate, adjacent to the driver's left foot. With the headlights switched on, operation of the switch changes the light beams from dipped to main beam or vice versa. A warning light on the turn light switchboard illuminates when the main beams are on.

Warning lights - oil pressure and main indicator generator

21 The oil pressure and main indicator Gen warning lights are press to test type lights. To change a lamp, refer to Para 12.

Warning lights – turn-light and main beam

22 These lights are similar to those fitted to the instrument panel but have a coloured lens in place of the moulded holder.

23 The turn-light and main beam warning lights are fitted at the left side of the driver's switchboard (Fig 6) and have an amber and a blue lens respectively

24 To change a lamp ensure the relevant circuit is turned OFF and refer to Para 16.2.

**Auxiliary junction box**

25 Table 8 details the functions of the controls on the auxiliary junction box; the number in brackets in the control/instrument column (2) refers to the key identification of Fig 7.



TABLE 8 AUXILIARY JUNCTION BOX

Serial (1)	Control/instrument (2)	Description (3)	Identification (if any) (4)
1	Fuse (1)	10A cartridge fuse to protect the supply circuits to serials	F5
2	Fuse (2)	5A cartridge fuse to protect three interior lights and the right hand socket used for additional lighting when the vehicle is converted for other roles.	F4
3	Fuse (3)	5A cartridge fuse, not used in this application.	F3
4	Fuse (4)	5A cartridge fuse to protect three interior lights and the left right hand socket used for additional lighting when the vehicle is converted for other roles.	F2
5	Fuse (5)	5A cartridge fuse to protect the driver's periscope or hood wiper motor.	F1
6	Switch (6)	This switch is not used in this application	SWITCH No. 1
7	Interior light switch (7)	Switch controlling the interior lights and two sockets when the vehicle is converted to the command role.	SWITCH No. 2

Changing a fuse

26 Switch off the relevant circuit (Fig 7), proceed as detailed in Para 8.2.

**Horn push button**

27 The horn push button (Fig 1(13)) is located to the right of the driver's switchboard and operates the traffic horn.

**Smoke grenade dischargers**

28 Refer to Chap 2-2 of this publication.

**Fire alarm system**

29 Refer to Chap 2-1 of this publication.

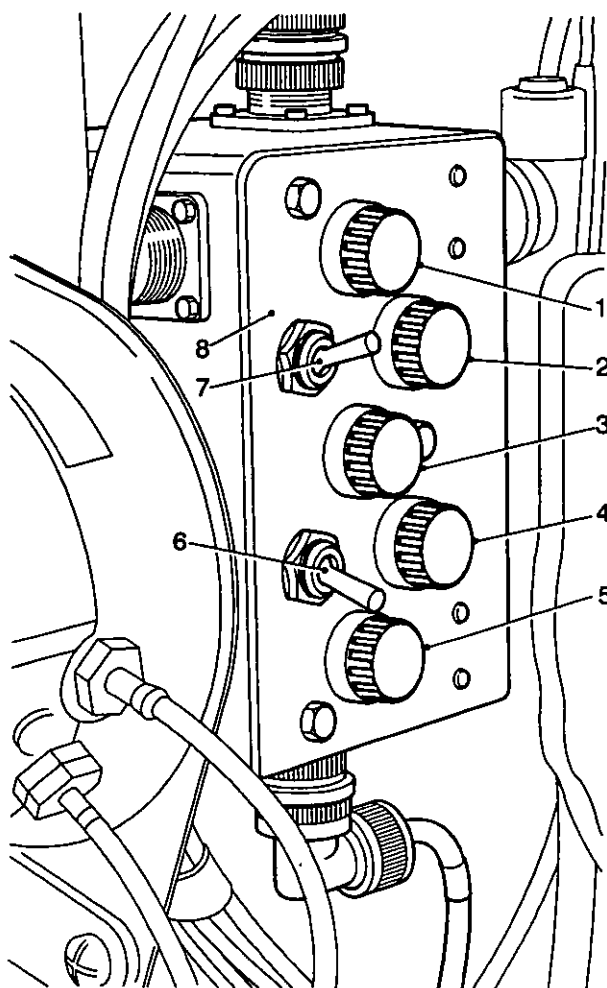

432/091

- 1 Fuse F5
- 2 Fuse F4
- 3 Fuse F3
- 4 Fuse F2

- 5 Fuse F1
- 6 Switch No. 1
- 7 Switch No. 2
- 8 Auxiliary junction box

Fig 7 Auxiliary junction box

### Wiper switch

30 A toggle switch located to the right of the driver's periscope screen washer unit and controls the operation of the periscope (or hood) wiper motor

### Distribution link box warning light

31 The distribution link box warning light (Fig 3(10)) is a small press to test type warning light fitted to the left hand side of the distribution link box, below the instrument panel. Under normal conditions, with the alternators charging, the light is dim, if the radio batteries positive line is earthed, the light is bright. If the radio battery connections are reversed, the light is bright before the engine is started, if the engine is started in this condition the lamp will glow excessively and burn out Internal damage will also be caused to the charging system.

### Changing a lamp

32 The distribution link box warning light (Fig 3(10)) is a press to test type light. Refer to Para 16 for the procedure to change a press to test lamp.

**Alternators****WARNING**

**PERSONAL INJURY. THE ALTERNATORS GET EXTREMELY HOT WHEN RUNNING.**

33 Two alternators mounted back to back, are driven at 2.94 times the engine output speed, which is shown, on the tachometer (Fig 5(1)). Each alternator is a 228.6 mm (9 in.), oil cooled, 3-phase alternator having a solid rotor and hence no slip rings and brushes. Special insulating material is used in the windings to permit working at high temperatures.

**Charging the batteries with the vehicle stationary****CAUTION**

**EQUIPMENT DAMAGE. When working in sub-zero conditions the batteries must be kept fully charged, otherwise the electrolyte may freeze. For further maintenance, reference should be made to the appropriate AESP listed under Associated Publications.**

34 The procedure to charge the batteries with the vehicle stationary is as follows:

34.1 Start the engine.

34.2 Slacken the wing nut (Fig 8(1)) on the engine speed hand control and turn the knurled head (2) of the screw to increase the engine speed until the generator warning lights on the engine switchboard (Fig 6(2)) and radio distribution box (Fig 3(6)) or Fig 4(6)) extinguish.

**NOTES**

(1) The generator warning light illuminates when the engine switch is put to ON and extinguishes when the alternators reach the charging voltage. If the light does not illuminate when the engine switch is put to ON, press the lens, if the light does not illuminate, renew the lamp, if it does illuminate report to REME.

(2) The generator lamp illuminates when the radio battery switch is in the ON position, providing the external charge switch is in the OFF position and is extinguished when charging starts.

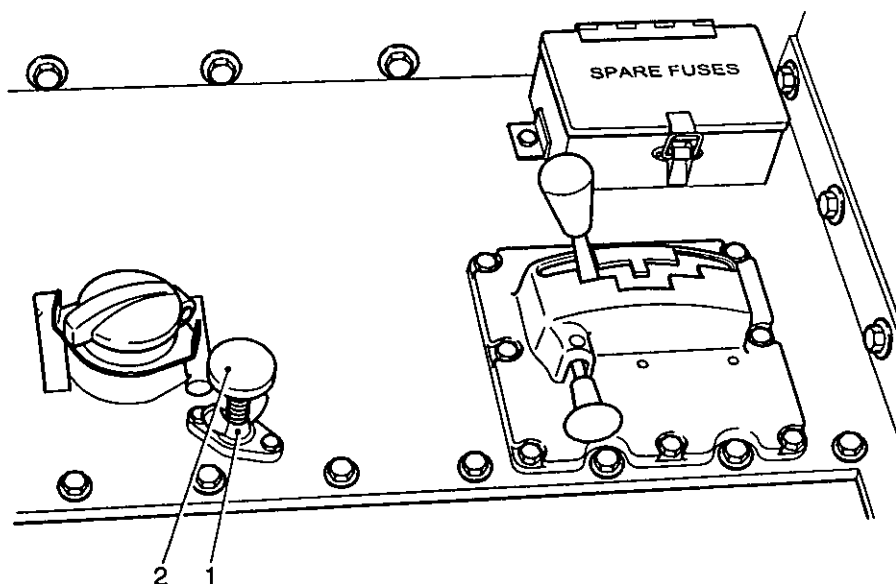

432/087a

1 Wing nut locking control

2 Engine speed hand control

Fig 8 Gear range selector

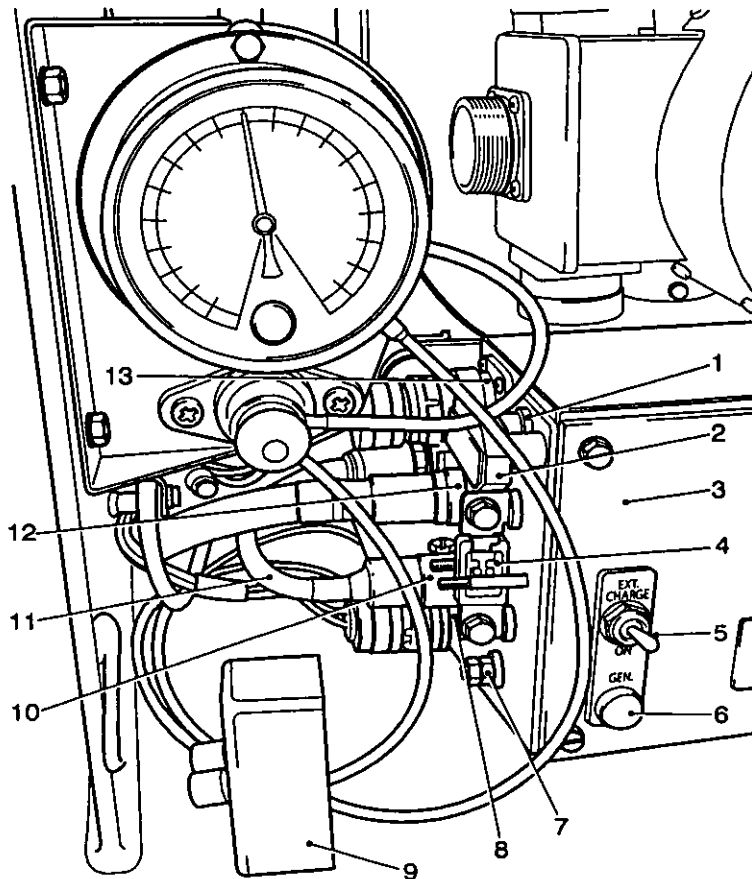

432/089

- |   |   |    |   |
|---|---|----|---|
| 1 | Terminal No. 4 - charging set positive connection | 8  | Socket No. 2 - radio junction box connector |
| 2 | Terminal cover                                    | 9  | Fuse cover                                  |
| 3 | Radio distribution box                            | 10 | Dummy plug                                  |
| 4 | Radio fuse  | 11 | External link                               |
| 5 | External charge switch                            | 12 | Plug No. 1 - link box positive connection   |
| 6 | GENERATOR warning light                           | 13 | Socket No. 3 - radio junction box           |
| 7 | Terminal No. 5 - negative connection              |    |   |

Fig 9 Radio distribution box fuse (Mk 2 vehicles)

**Batteries**

General

36 Three sets of batteries are fitted - automotive, ventilation and radio. The automotive batteries (Fig 10(1)) are located on the sill to the right of the driver's seat, the radio batteries (Fig 12) beneath the driver's seat (to obtain access to the batteries beneath the driver's seat, see Chap 2-2) and the ventilation batteries (Fig 11) to the rear of the radio batteries, underneath the commander's seat.

37 Each pair of batteries is housed in a fibreglass container (Fig 11(8)), which in turn is located in an angle framework (9) bolted to the vehicle. The batteries sit on felt strips located on a teak framework. A clamp bar (7) with felt strip straddles the two batteries and is held by two hinged bolts (11) attached to the frame and fitted with a seating collar, a shock absorbing spring, washer and nut.

**CAUTION**

**EQUIPMENT DAMAGE.** Each pair of batteries must be of the same type, (i.e. both maintenance free)

38 There are two types of battery, maintenance free or maintenance required. Either type can be fitted to the vehicle. Maintenance free batteries are issued as replacements for maintenance required batteries. However, it is imperative that batteries are of the same type, are fitted throughout the vehicle, so it may be necessary to change all five batteries even though only one has failed, assuming they were all maintenance required.

#### **WARNING**

**FIRE HAZARD. THE GASES RELEASED FROM THE BATTERY ARE HIGHLY INFLAMMABLE. IT IS IMPORTANT THEREFORE THAT THE BATTERY VENTING SYSTEM IS MAINTAINED IN GOOD CONDITION. IT IS ALSO IMPORTANT ELECTRICAL CONNECTIONS MUST BE MAINTAINED CLEAN AND TIGHT TO PREVENT ARCING AND POSSIBLE IGNITION OF GASES. A NAKED LIGHT MUST NEVER BE USED WHEN EXAMINING A BATTERY.**

39 In the roof of the personnel compartment adjacent to the front right interior light are two flame trap vents provided for additional batteries required in the command role. Blanking plugs seal the flame trap vents when not in use.

#### Maintenance free batteries

40 Maintenance free lead acid batteries must be fitted in sets. Each set consists of two 12 V 110Ah batteries connected in series to give a 24V 110Ah supply.

41 Each battery connector is a split clamp type, enclosed by a flexible insulating cover. To safe guard against inadvertently reversing battery connections, the positive and negative terminal posts of each battery are of different diameters. As a further safeguard the positive terminal is encircled by a red collar and the negative terminal by a blue collar.

42 An insulated terminal (Fig 11(4) is provided adjacent to the ventilation batteries to house the battery positive connection when disconnected from the ventilation batteries.

43 When maintenance free type batteries are fitted, the battery venting system of the vehicle is connected to a venting manifold on top of the battery.

#### Cleaning and checking maintenance free batteries

44 To check and clean maintenance free batteries proceed as follows:

#### **WARNINGS**

(1) **LETHAL VOLTAGE. BEFORE REMOVING OR REPLACING BATTERY CONNECTION, ENSURE THAT THE ENGINE IS STOPPED. SET THE BATTERY SWITCH, LOCATED ON THE DISTRIBUTION PANEL AND RADIO DISTRIBUTION BOX, TO OFF.**

(2) **HEAVY WEIGHT. EACH BATTERY WEIGHS APPROXIMATELY 38Kg (84 lb).**

(3) **LETHAL VOLTAGE. WHEN DISCONNECTING BATTERIES, REMOVE ALL THE TERMINALS FROM THE EARTH (NEGATIVE) (-) TERMINAL POSTS BEFORE REMOVING THE SUPPLY (POSITIVE) (+) TERMINALS. REPLACE IN THE REVERSE ORDER (POSITIVE TERMINALS FIRST).**

44.1 Examine the battery for damage, included cracked, split or overheated/distorted case, loose or burnt away terminals and corrosion.

44.2 Ensure the battery terminals are clean. If corrosion is visible, carefully lift the connector cover and then disconnect the faulty connector from its post. To prevent short-circuiting to nearby metal, always disconnect the negative terminal first. Scrape away corrosion and wash the connector and post with ammonia or soda solution to neutralize the acid. Replace the connector. Always fit the positive terminal first.

- 44.3 Ensure the batteries are secure within the tray.
- 44.4 Ensure the connector terminals are tight.

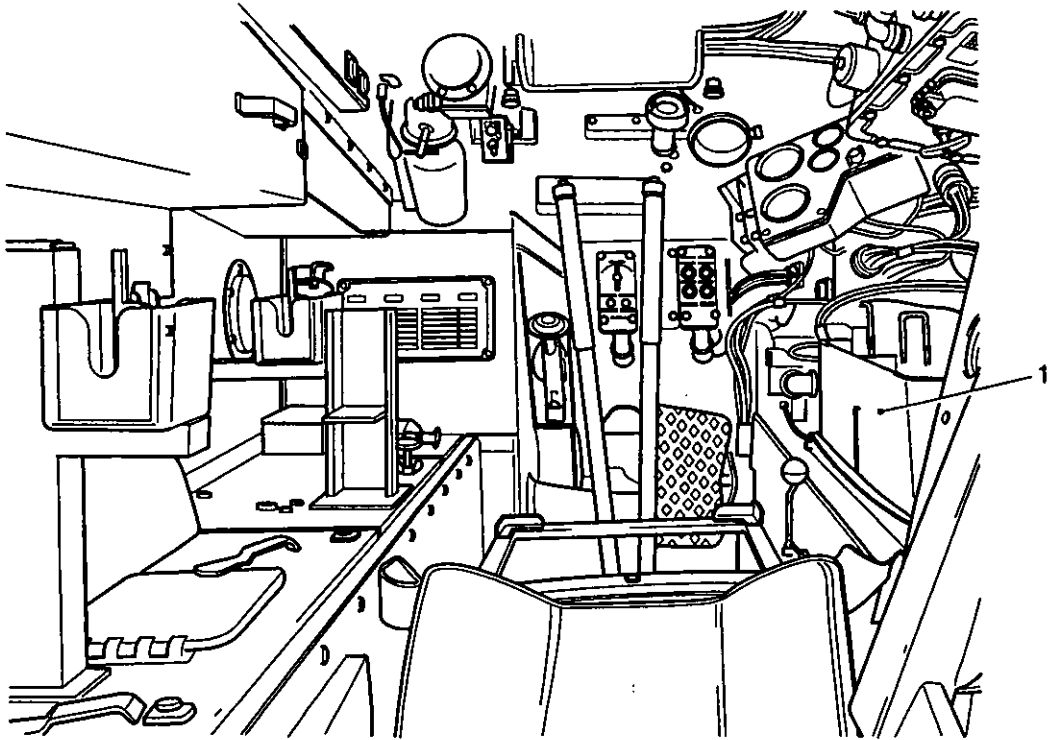

430/20130

- 1 Automotive batteries

Fig 10 Driver's compartment

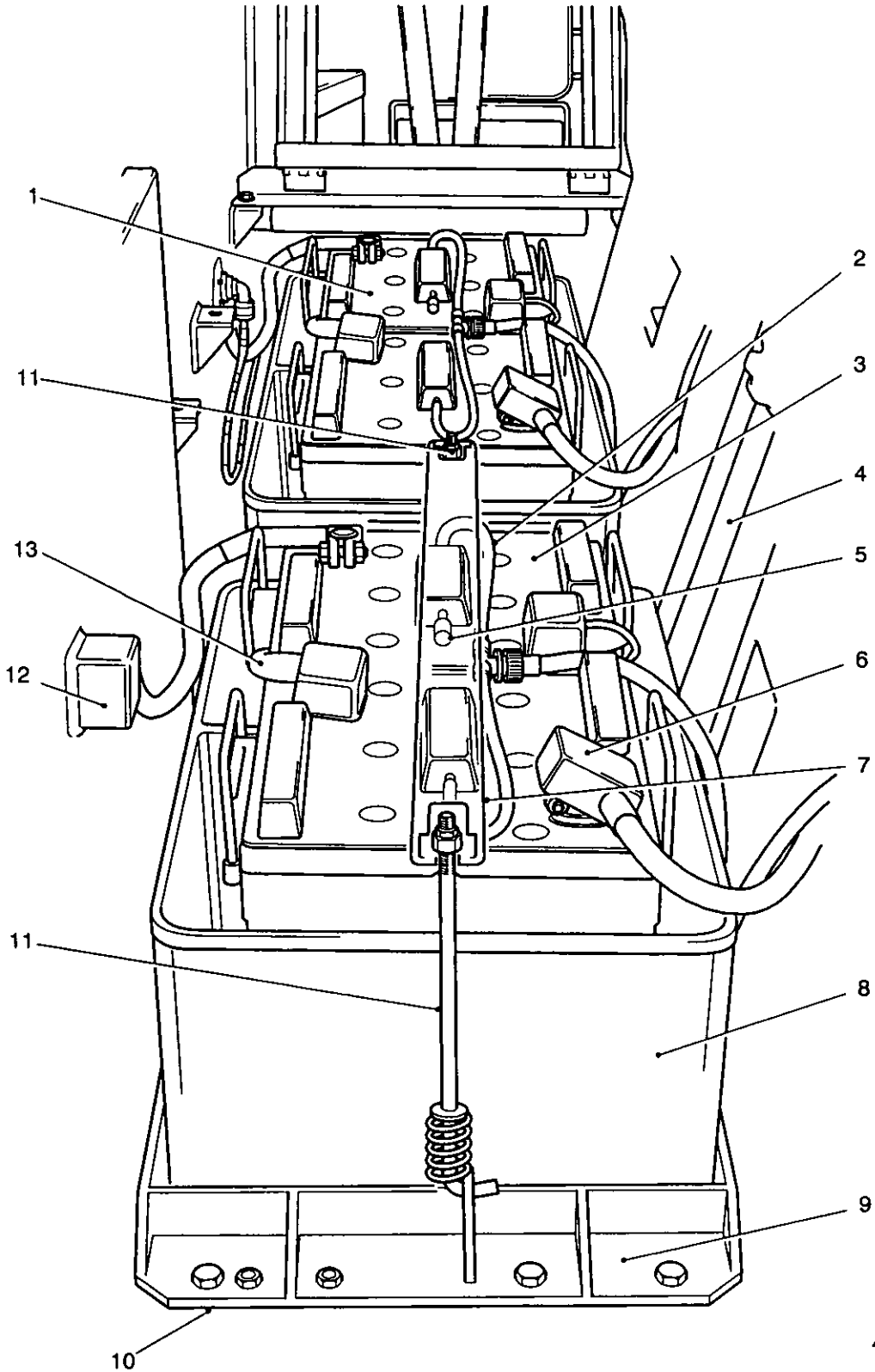

430/20135

- |   |                            |    |                                     |
|---|----------------------------|----|-------------------------------------|
| 1 | Radio battery              | 8  | Battery container housing           |
| 2 | Vent tube assembly         | 9  | Battery container bracket           |
| 3 | Ventilation battery        | 10 | Packing strip                       |
| 4 | Insulated stowage terminal | 11 | Battery clamp bolts                 |
| 5 | Seal caps                  | 12 | Battery negative (earth) connection |
| 6 | Positive terminal          | 13 | Inter connecting lead               |
| 7 | Battery clamp              |    |                                     |

Fig 11 Ventilation batteries (Maintenance free type)

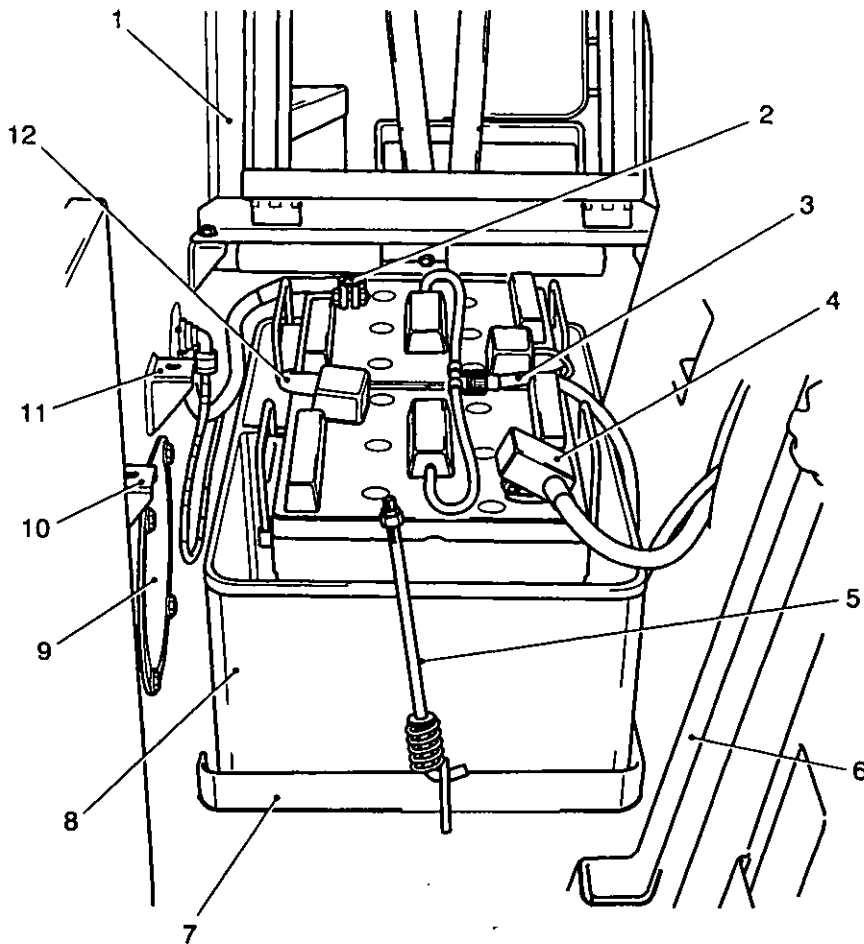

432/045

- |   |                    |    |                              |
|---|--------------------|----|------------------------------|
| 1 | Seat frame         | 7  | Container housing frame      |
| 2 | Negative terminal  | 8  | Container                    |
| 3 | Vent tube assembly | 9  | Access plate, gearbox filter |
| 4 | Rubber cover       | 10 | Footrest bracket             |
| 5 | Battery clamp bolt | 11 | Seat bracket                 |
| 6 | Battery clamp bar  | 12 | Inter-connector              |

Fig 12 Radio batteries (Maintenance free type)

To remove a battery from the vehicle

**NOTE**

For manufacturing details of the battery-lifting tool, refer to AESP 2350-T-251-522.

**WARNINGS**

- (1) **LETHAL VOLTAGE. WHEN DISCONNECTING BATTERIES, REMOVE ALL THE TERMINALS FROM THE EARTH (NEGATIVE) (-) TERMINAL POSTS BEFORE REMOVING THE SUPPLY (POSITIVE) (+) TERMINALS. REPLACE IN THE REVERSE ORDER (POSITIVE TERMINALS FIRST).**
- (2) **LETHAL VOLTAGE. BEFORE REMOVING OR REPLACING BATTERY CONNECTION, ENSURE THAT THE ENGINE IS STOPPED. SET THE BATTERY SWITCH, LOCATED ON THE DISTRIBUTION PANEL AND RADIO DISTRIBUTION BOX, TO OFF.**
- (3) **HEAVY WEIGHT. EACH BATTERY WEIGHS 38 KG (84 LB). DUE CONSIDERATION MUST BE GIVEN TO THE REGULATIONS GOVERNING THE LIFTING OF HEAVY WEIGHTS WHEN MOVING EQUIPMENT.**



**(4) PERSONAL INJURY. THE ACID IN THE CELLS IS HARMFUL AND MUST NOT BE ALLOWED TO CONTACT THE EYES, SKIN OR CLOTHING.**

45 The procedure to remove any of the batteries is similar and is as follows:

- 45.1 Switch all battery master switches to OFF.
- 45.2 For the radio batteries, remove the driver's seat assembly.
- 45.3 Release the nuts holding clamp (Fig 11(11)) and the remove clamp (7).
- 45.4 Remove the ventilation tube (2) and the T-connection.
- 45.5 Remove the battery negative connection (12).
- 45.6 Remove the battery positive connection (6) and connecting strap (13).
- 45.7 For the hull batteries, remove battery container securing strip and slide container with batteries onto driver's seat.
- 45.8 For the radio batteries, lift commander's seat foot platform to vertical position.
- 45.9 Using special battery lifting tool, detailed at Para 48, move batteries from vehicle individually out through the driver's hatch or back through the crew compartment.

#### Refitting

46 Refit in reverse order to removing.

#### Testing

47 Depending on which set of batteries have been replaced, carry out functional test on corresponding system: hull - ensure engine starts; radio – ensure radio operates under all conditions; ventilation – ensure fan operates.

#### Battery lifting tool

48 To facilitate removing and refitting of batteries, a special tool may be manufactured locally. For manufacturing details see AESP 2350-T-251-522 Chap 5.

#### NOTES

(1) There are currently two types of batteries fitted to the FV430 Series. These are Maintenance Free (New type (Grey coloured)) and Non-maintenance free (Old type (Black)). The 'Old type' battery is no longer issued and has been superseded by the new maintenance free type battery. It is imperative that each pair of batteries is of the same type, (i.e. both maintenance free)

(2) The care and maintenance of maintenance required for lead acid batteries is detailed in AESP 6160-T-100-013.

#### **Inspection light sockets**

49 An inspection light or AFV spotlight socket is incorporated in the distribution panel. A captive protective screw cap (Fig 2(2)) is provided and must be fitted when the socket is not in use.

#### **Interior lights**

50 Six interior lights are provided which are controlled by switch No. 2 (Fig 7(7)) on the auxiliary junction box in parallel with the rear door operated switch; each light incorporates its own switch and dimmer resistance.

51 Under normal conditions put switch No. 2 (Fig 7(7)) on the auxiliary junction box to 'ON' then switch on the individual lights as required.

52 Under blackout conditions put switch No. 2 to 'OFF' (Fig 7(7)) then set the individual light switches to provide the minimum amount of light for the task in hand, when the rear door is opened the door operated switch extinguishes the light.

53 The right rear and the left forward lights in the personnel compartment are fitted with adaptor sockets for use with supplementary role kits.

### **Spotlight**

54 The spotlight (Fig 3(3)) is normally stowed on the right sill to the rear of the radio distribution box (2). A bracket for the working position of the light is located on the cupola periscope guard.

55 The light is similar to the headlight; the same type of light unit and lamp is fitted but, in this instance, only the main filament is used. The light has an ON-OFF switch and 9 metres (30 feet) of cable, which terminates in a 2-pin plug to fit into the distribution panel socket (Fig 2(2)).

56 A bracket is provided for mounting purposes, this is connected to the light via a right-angled bracket, and two turn buttons, which permit the light to be easily swivelled or deflected. The light is stem mounted to the bracket. A ball and socket joint between the light body and stem, and a handle attached to the body, provides another method of controlling the direction of the light after slacking off the stem nut.

57 When not in use the cable may be wrapped round the body to locate against the stem, handle and two brackets fitted at each side of the light. A dummy socket to house the plug is fitted to the light handle.

### Changing a lamp

58 The procedure for changing a spotlight is as follows:

58.1 Put the spotlight switch to OFF.

58.2 Slacken the screws securing the clips to the rim until the clips can be swung aside (Fig 16)

58.3 Support the rim, swing aside the clips, and withdraw the rim and light unit (1) assembly.

58.4 Whilst supporting the rim and light unit press the lamp adaptor (3) and lead assembly towards the light unit, turn it anti-clockwise and withdraw the adaptor.

58.5 Withdraw the lamp and fit a new one, taking care to engage the slot of the lamp plate with the key of the lampholder.

58.6 Check that the spring-loaded contacts of the adaptor (3) are satisfactory. Engage the projections on the adaptor with the slots of the lampholder. Press the adaptor onto the holder and secure it by turning clockwise.

58.7 Test the lamp. If it still does not function report to REME.

### **Amber rotating beacon**

59 An amber rotating beacon is fitted to the rear of the roof and is used when the vehicles are to be driven on public roads to warn other road users of a slow moving vehicle.

60 The rotating beacon is connected via a cable harness to the mini fascine socket. To operate the rotating beacon, switch on the normal driving lights.

**External lighting socket**

61 A 4-way socket with a captive screw on cover is fitted to the side of the power tool socket (no longer used) at the rear of the vehicle and provides a connection point for external lighting purposes such as penthouse lighting. The supply to the socket is controlled by the external lighting switch located on the distribution panel No. 6 Mk 1 (Fig 2(8)).

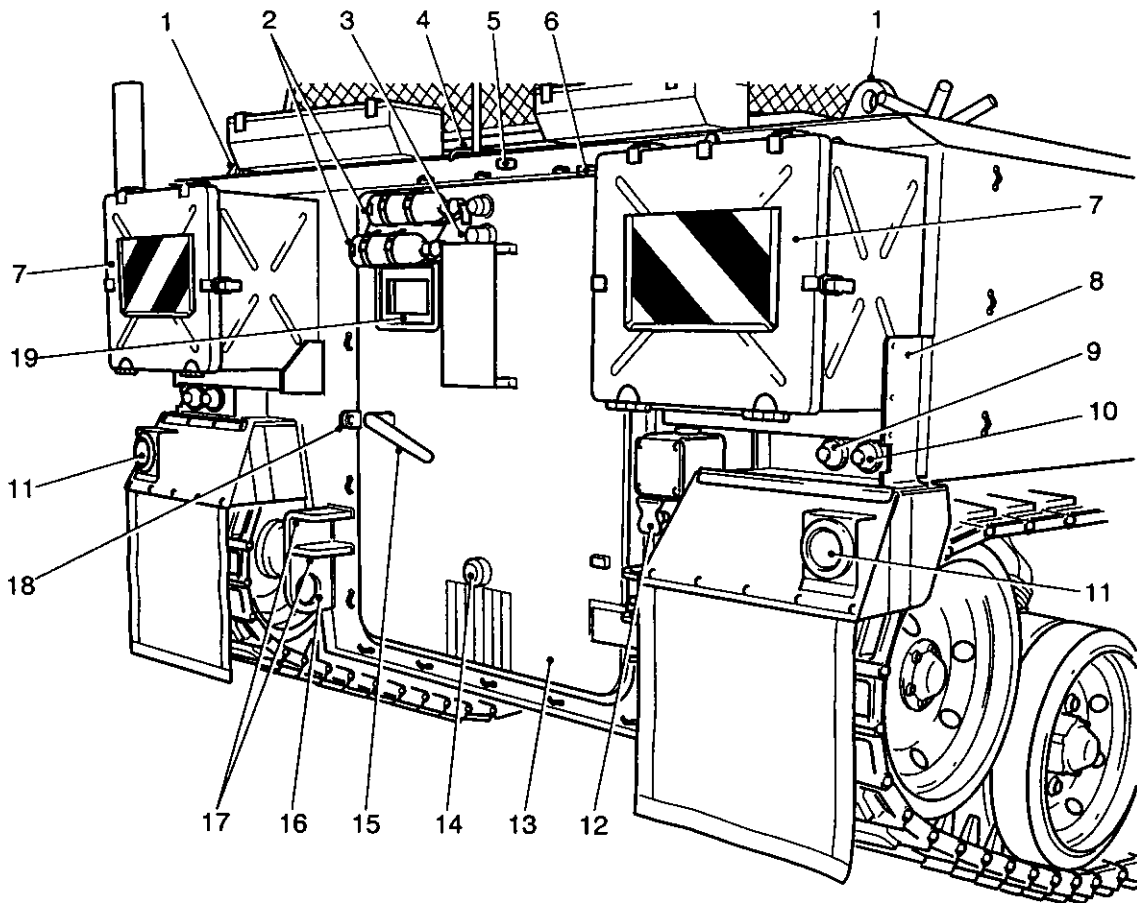

430/20019

1	Lifting eyes	10	Tail/stop light
2	Portable fire extinguishers	11	Red reflector
3	Registration plate light	12	12-way trailer socket
4	Fuel vent pipe	13	Rear door
5	Drain plug	14	Convoy light
6	Staple	15	Door handle
7	Stowage boxes	16	Towing eye
8	Plate for penthouse kit stowage bracket (Mk 2/1 vehicles only)	17	Tow bar bracket
9	Turn-light	18	Padlock hasps
		19	Observation window

Fig 13 Rear of vehicle

**Boiling vessel sockets**

62 Two sockets are provided on the distribution panel (Fig 2(4)) into which the plugs of boiling vessels may be fitted. The sockets are 'dead' unless the alternators are operating. Captive screw caps are provided for the sockets when not in use.

63 When the engine is running and a boiling vessel is in use, the connection, and disconnection, of the boiling vessel harness must be made at the boiling vessel end by means of the push-on/pull-off connector, which is specially designed to prevent burning of the pins.

### Boiling vessel

#### CAUTION

**EQUIPMENT DAMAGE.** Connection and disconnection of the harness must be made at the boiling vessel by means of the push-on/pull-off connector.

#### NOTE

To ensure the correct use of the boiling vessel, No 1 Mk 1 and to safeguard the element, a warning plate has been secured above the drain tap.

64 The boiling vessel can provide boiling water for beverages, shaving, washing, etc and at the same time heat up tinned or decanted foods. It can also be used for frying.

65 The vessel comprises a stainless steel, corrosion-resistant water compartment Fig 14(14)), a removable stainless steel inner food container (7) and a removable lid (3). The water compartment and lid are insulated to reduce heat loss and to reduce the possibility of accidental burns and scalds.

66 Power is supplied via two sockets (Fig 2(4)) on the distribution panel No. 6 when the alternators are 'on-line'. When the connecting cable is coupled to the vessel socket (Fig 14(12)) a relay closes and the vessel-heating element is energized.

67 The drain tap (11) has a push button operated valve, which can be dismantled for cleaning. The dismantling does not require any special tools.

68 When the lid is closed it forms a watertight seal and the vent (1) is necessary to allow steam to escape. The vent must be kept clear at all times. The lid can be used as illustrated for the removal of the inner food container during cooking operations.

### Boiling

#### CAUTIONS

(1) **EQUIPMENT DAMAGE.** To avoid seriously damaging the electrical element, the inner container must be in place within the vessel when boiling less than 1.14 litres (2 pints) of water.

(2) **EQUIPMENT DAMAGE.** Do not make coffee, soups etc in the water compartment, as this heavy fluid will cause the drain tap to malfunction.

69 Release the toggle clips (Fig 14(13)), remove the lid, and lift out the inner food container. Pour the required measure of water into the container but DO NOT FILL ABOVE THE 7 PINT (3.9 LITRE) LEVEL LINE ENGRAVED WITHIN THE WATER COMPARTMENT. Replace the lid, fasten the toggle clips and engage the cable socket to the plug (12) then switch ON. Approximate times for water to boil are shown in table 11.

TABLE 9 TIMES FOR WATER TO BOIL

Quantity (1)	Time (2)
1.1 litres (2 pints)	9 minutes
1.7 litres (3 pints)	11 minutes
2.2 litres (4 pints)	13 minutes
2.8 litres (5 pints)	16 minutes
3.4 litres (6 pints)	19 minutes
3.9 litres (7 pints)	25 minutes

Making beverages**CAUTION**

**EQUIPMENT DAMAGE.** Do not make coffee, soups etc in the water compartment, as this heavy fluid will cause the drain tap to malfunction.

70 Place tea, coffee, cocoa or soup powder, etc into the inner food container. Boil the water (Para 69), switch OFF, and disconnect the plug. Position food container under tap and draw off by pressing the tap push-button.

**NOTE**

The food container capacity is approximately 2.56 litres (4.5 pints).

Heating compo rations - decanted

71 Release the toggle clips, remove the lid, and lift out the inner food container. Measure 1.1 litres (2 pints) of water into the water compartment, DO NOT FILL ABOVE THE 1.1 LITRE (2 PINT LEVEL). Pour the contents of five tins of compo rations into the food container, replace the container in the vessel, then replace and secure the lid. Engage the cable socket to the plug and switch on, leave for approximately 25 minutes, for the food to heat. Switch 'OFF', disconnect the cable, and then using the out-turned clip hooks on the lid to engage the inner container-folding handle, lift the container out.

**NOTE**

Food left in the vessel will remain hot for up to 4 hours. The boiling water remaining in the water compartment can be used for beverages or washing etc.

Heating compo rations - undecanted**WARNING**

**PERSONAL INJURY.** TO AVOID CANS PRESSURISING IT IS ESSENTIAL WHEN HEATING COMPO RATIONS UNDECANTED THAT THE TOPS OF THE CANS ARE PIERCED AND THAT THE TINS ARE NOT TO BE PLACED ONE ON TOP OF THE OTHER.

72 Proceed as in Para 71 but placing up to three tins of compo rations, with TOPS PIERCED, in the inner container. When heated, remove the compo ration tins, open them carefully, and serve.

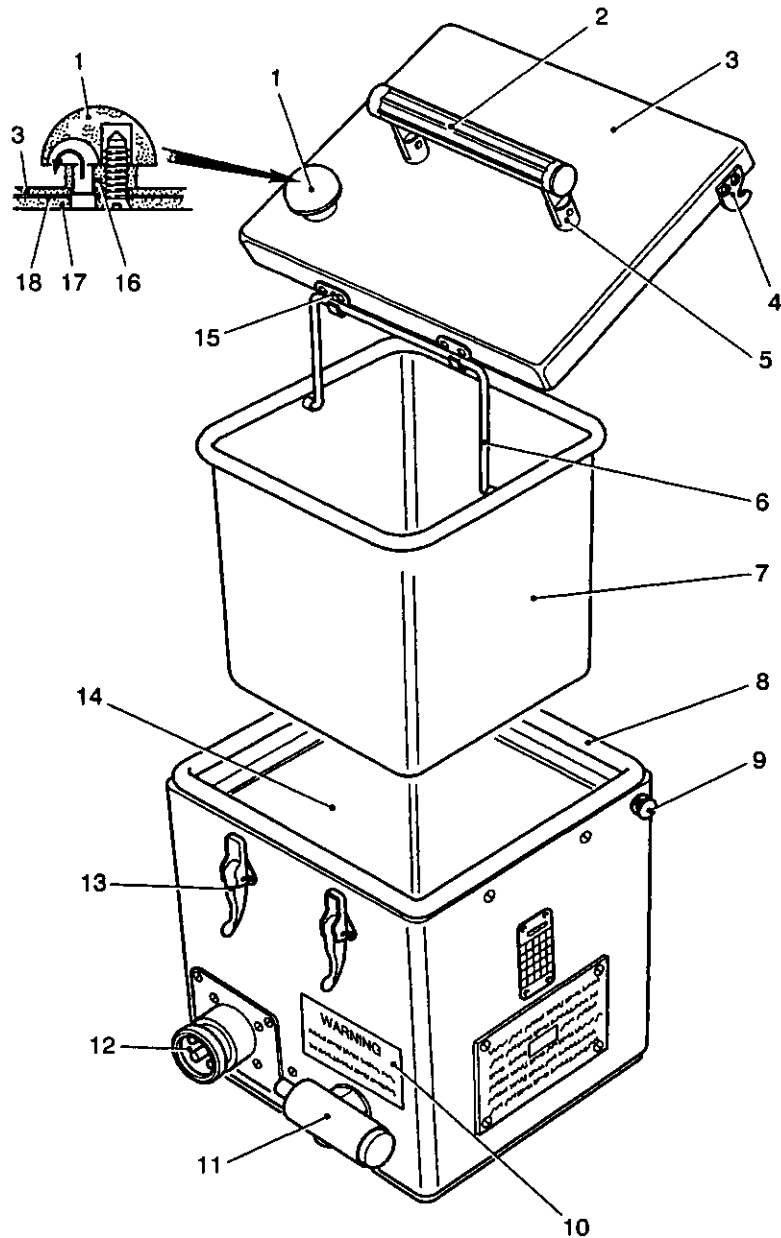

432/371

- |   |                         |    |                        |
|---|-------------------------|----|------------------------|
| 1 | Domed vent              | 10 | Warning plate          |
| 2 | Lifting handle          | 11 | Drain tap              |
| 3 | Insulated lid           | 12 | Electrical supply plug |
| 4 | Locating hooks          | 13 | Lid toggle clips       |
| 5 | Handle hinge posts      | 14 | Water compartment      |
| 6 | Foldaway lifting handle | 15 | Front hooks            |
| 7 | Inner food container    | 16 | Spacer                 |
| 8 | Seal                    | 17 | Plastic lining         |
| 9 | Lid hook studs          | 18 | Gasket                 |

Fig 14 Boiling vessel

Frying

**WARNINGS**

**(1) PERSONNEL INJURY. DEEP FRYING MUST NOT BE ATTEMPTED. THE OIL/FAT COULD BOIL OVER AND A SERIOUS FIRE OR INJURY RESULT**

(2) **PERSONNEL INJURY. THE BASE OF THE WATER COMPARTMENT BECOMES RED HOT WHEN FRYING, DO NOT ATTEMPT TO COOL BY POURING WATER INTO THE COMPARTMENT. SERIOUS SCALDING MAY RESULT.**

(3) **PERSONNEL INJURY. CARE MUST BE TAKEN WHEN REFILLING WITH WATER SOON AFTER FRYING. SERIOUS SCALDING MAY RESULT.**

#### CAUTION

**EQUIPMENT DAMAGE.** The vessel must not be stood on a damp surface, especially if the vessel is hot, as moisture can be drawn up into the insulation material.

73 Remove lid and inner container, drain off inner container, and ensure water compartment is clean.

74 Place a small quantity of cooking fat in the bottom of the inner food container and replace the container.

75 Engage the cable socket to the plug and switch on. At the first indication of the blue smoke arising from the melted fat, place food for frying (sausages, bacon, eggs, etc) into the hot fat and fry until cooked. Switch 'OFF' and unplug the cable. Lift out container and serve food. Approximate cooking times are:

Sausages	10 minutes
Rashers of bacon	2-3 minutes
Eggs	1-2 minutes

#### Boiling vessel servicing

#### WARNING

**PERSONAL INJURY. PETROL OR OIL DERIVATIVES MUST NOT BE USED UNDER ANY CIRCUMSTANCES. THEY CAUSE SILICONE SEALS TO SWELL AND SEALS THAT HAVE SWOLLEN ARE TOXIC. ANY SEAL THAT HAS BECOME CONTAMINATED MUST BE CHANGED BEFORE THE VESSEL IS AGAIN USED.**

#### Cleaning the inner food container

76 Remove the inner food container (Fig 14(7)) and clean by scouring, rinse, drain and wipe dry.

#### Cleaning the water compartment

77 Clean the water compartment (Fig 14(14)) by scouring, rinse, drain, and wipe dry. Alternatively, cleaning can be effected using boiling water to which soda or detergent has been added and running the water through the drain tap; the compartment and tap must be rinsed thoroughly before use.

#### Drain tap

78 The procedure to clean the drain tap is as follows:

78.1 Unscrew slotted end stop (Fig 15(4)), using a coin or suitable implement.

78.2 Remove the spring (3).

78.3 Remove the valve plunger assembly (2).

78.4 Clean all parts, dry off, and reassemble in reverse sequence.

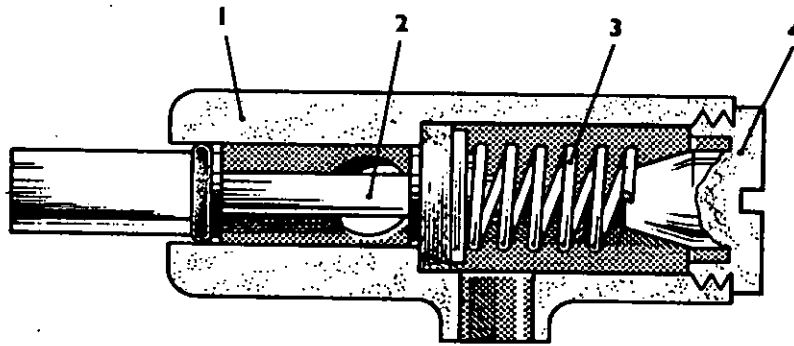

432/100

- |   |                        |   |          |
|---|------------------------|---|----------|
| 1 | Body                   | 3 | Spring   |
| 2 | Valve plunger assembly | 4 | End stop |

Fig 15 Drain tap

Lid

79 The procedure to clean the drain tap is as follows:

- 79.1 Remove the domed vent cap (Fig 14(1)) and spacer (16) by unscrewing the countersunk retaining screw.
- 79.2 Unscrew the remaining two countersunk screws, which secure the handle (2), from the inner face of the lid.
- 79.3 Dismantle the lid and clean.
- 79.4 Reassemble in reverse sequence, ensuring that the vent apertures align, and the sealing gasket (18) seats correctly.

**Headlight**

Changing a lamp

**WARNING**

**DAMAGE TO EYESIGHT. THE INFRA RED (IR) DRIVING LIGHTS ARE FITTED WITH 100 WATT LAMPS. THESE LIGHTS SHOULD NO LONGER BE USED. NEVER LOOK AT THE IR LIGHT WHEN THE FILTER IS FITTED AND THE LIGHT IS SWITCHED ON AS SERIOUS AND PERMANENT DAMAGE TO THE EYE MAY RESULT.**

80 The procedure for changing a headlight is as follows:

- 80.1 Put the headlight switch to OFF.
- 80.2 Slacken the screws securing the clips to the rim until the clips can be swung aside (Fig 16).
- 80.3 Support the rim, swing aside the clips, and withdraw the rim (1) and light unit (2) assembly.
- 80.4 Whilst supporting the rim and light unit press the adaptor (4) and lead assembly towards the light unit, turn it anti-clockwise and withdraw the adaptor.
- 80.5 Withdraw the lamp (3) and fit a new one, taking care to engage the slot of the lamp plate with the key of the lampholder.
- 80.6 Check that the spring-loaded contacts of the adaptor (4) are satisfactory. Engage the projections on the adaptor with the slots of the lampholder. Press the adaptor onto the holder and secure it by turning clockwise.



80.7 Test the lamp. If it still does not function report to REME.

80.8 Locate the light unit and rim assembly in position in the body (5), ensuring that the TOP marks are at the top. Check that the sealing gasket (7) fits correctly, press the unit into position, and secure it with the clips.

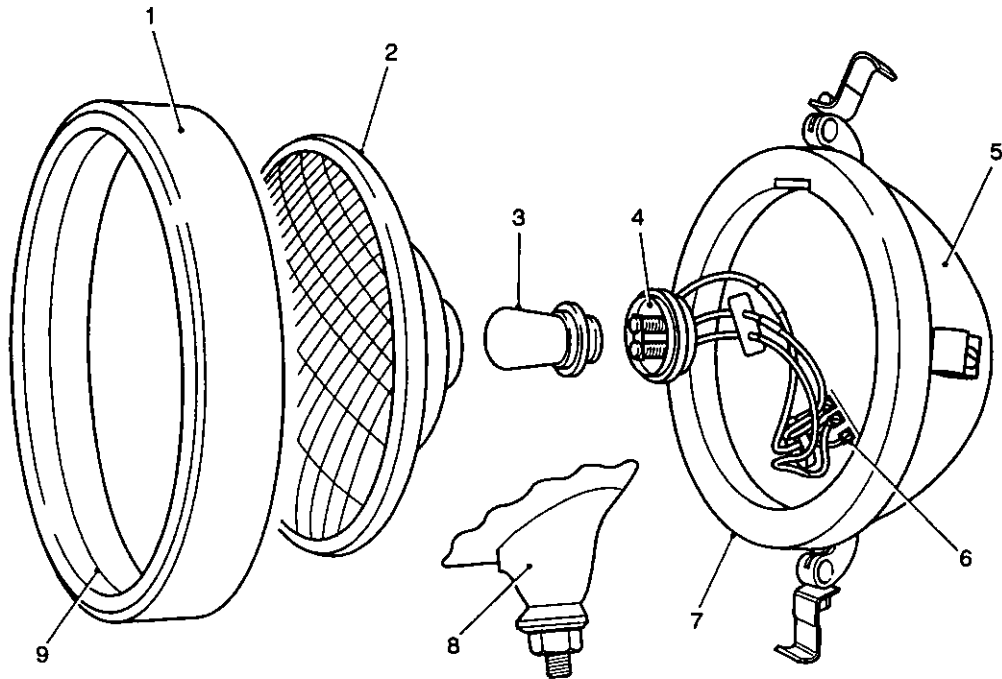

432/397

1	Rim	6	Terminal block
2	Light unit	7	Rear gasket
3	Lamp	8	Stem mounting
4	Adaptor	9	Front gasket
5	Body		

Fig 16 Headlight

### Side, turn, tail/stop and fire warning lights

81 The side, turn, and fire warning lights have an SCC lampholder assembly (Fig 17(3)) fitted in a rubber body (7), which in turn locates in a metal base (1) bolted to the mounting plate. The sidelights have a white domed lens (6) which screws into the light base, the turnlights have an amber lens, and the fire warning lights a red lens.

82 The tail/stop lights are similar to the sidelights but have a red lens and a double contact lampholder fitted with a 7/30 W double filament lamp. The 7 W filament provides the taillight and the 30 W the stoplight. The lamp cap has index type pins to ensure correct fitting.

### Changing a lamp

83 The procedure to change a lamp is as follows:

83.1 Put the appropriate light switch to OFF.

83.2 Unscrew the domed lens (Fig 17(6)) from the light. In the case of the fire warning light in the personnel compartment, it will be necessary to first remove the guard.

83.3 Remove the bayonet-fixing lamp from its holder.

83.4 Check that the spring-loaded contact is satisfactory, and then fit a new lamp. When doing this on the tail/stop light make sure that the index type pins are in the correct location. Test the lamp, if it still does not function report to REME.

83.5 Screw on the domed lens, taking care to ensure the threads are correctly engaged, and remain securely engaged throughout the screwing motion.

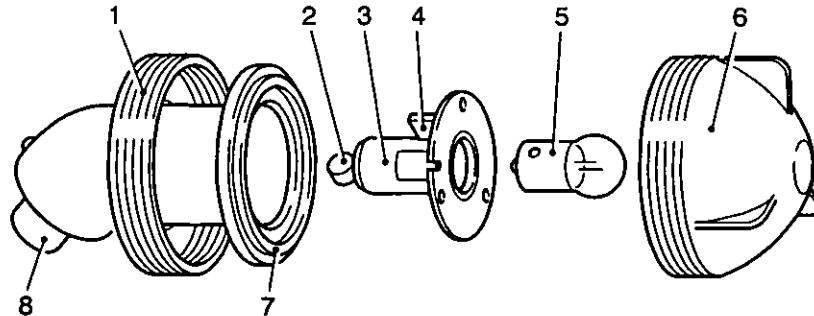

432/095

- 1 Base
- 2 Contact ferrule
- 3 Lampholder assembly
- 4 Earth ferrule

- 5 Lamp
- 6 Lens
- 7 Body
- 8 Cable gland

Fig 17 Sidelight

**Registration plate light and convoy light**

84 The registration plate light (Fig 18) and convoy lights (Fig 19) are mounted on the rear door, connections to the lights being by an assembly of three spring-loaded plungers attached to the inside of the hull rear plate, making contact with plates mounted on the inside of the doors.

Registration plate light

85 The cover of the registration light is cylindrical with a 180-degree light aperture. Fitted on the cover is a light shield (Fig 18(1)) with two light apertures, one similar to that of the cover and diametrically opposite a 3/8 in. dia hole. The shield is slotted to engage a locating peg (2) fitted to the cover, and the shield may be rotated on the cover, within the limits set by the peg, to give varying degrees of registration plate illumination.

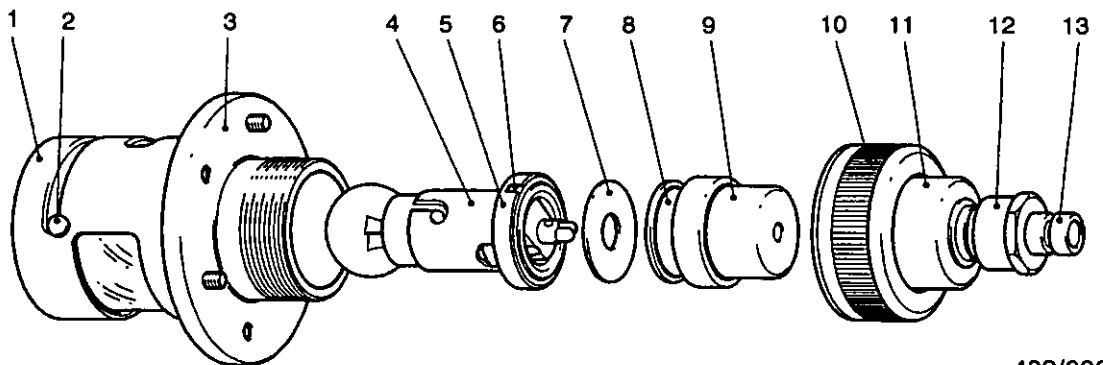

432/096

- 1 Light shield
- 2 Locating peg
- 3 Backplate and bush
- 4 Lampholder
- 5 Front rubber mounting
- 6 Earthing ring
- 7 Insulating washer

- 8 Lampholder cup
- 9 Rear rubber mounting
- 10 Locking ring
- 11 Case
- 12 Gland nut
- 13 Ferrule

Fig 18 Registration plate light

Changing a registration plate lamp

86 The procedure for changing a registration plate lamp is as follows:

86.1 Put the tail/side switch to OFF (Fig 6).

86.2 Unscrew the three slotted hexagon headed screws securing the front cover and carefully withdraw the cover together with its gasket.

86.3 Fit a new lamp (see Table 3), and replace the cover and gasket.

86.4 Test the lamp and if it still does not function report to REME.

Convoy Light

87 The convoy light (Fig 19) is a stem-mounted unit fitted in the bottom centre of the rear door. The light has a brass screwed cap (1) which has a plain glass window to permit illumination of the convoy markings, and a small red lens (3) which permits a small red light to be visible to the driver of a closely following vehicle in convoy.

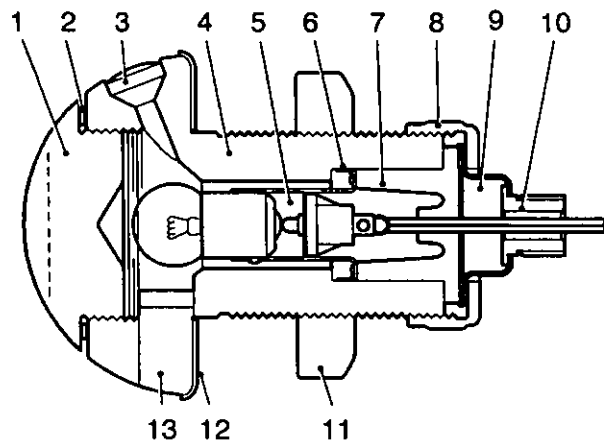

432/097

1	Cap	8	Locking ring
2	Sealing ring	9	Case
3	Red lens	10	Bush
4	Body	11	Locking nut
5	Lampholder	12	Window retaining cap
6	Earthing ring	13	Window
7	Rubber sleeve		

Fig 19 Convoy light

Changing a convoy lamp

88 The procedure for changing a convoy lamp is as follows:

88.1 Put the convoy switch to OFF (Fig 6).

88.2 Remove the guard on the inside of the door, which is secured by two nuts with spring and plain washers.

88.3 Unscrew the knurled ring nut on the light and withdraw the lampholder (Fig 19(5)).

88.4 Remove the bayonet fixing lamp and fit a new lamp, (see Table 3).

88.5 Refit the lampholder and test the light if it still does not function report to REME.

88.6 Replace the guard.

Servicing the rear door contacts

89 Periodically, or in the event of failure of the registration plate or convoy light, the door contacts (Fig 20) should be examined as follows:

- 89.1 Check that the contacts are clean and lightly smeared with grease.
- 89.2 Ensure that the spring-loaded plungers are satisfactory, if not report to REME.
- 89.3 Check that the plungers correctly engage the contact plate, if not report to REME.

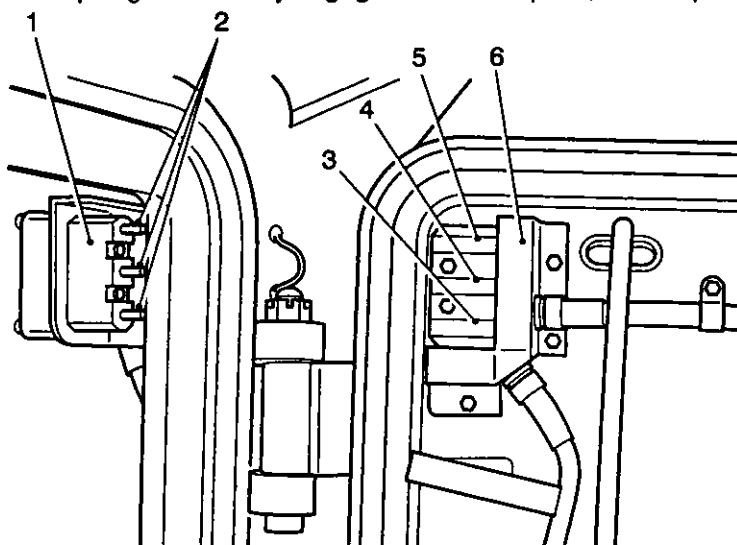

432/098

- |   |                         |   |                            |
|---|-------------------------|---|----------------------------|
| 1 | Contact plunger housing | 4 | Convoy light contact plate |
| 2 | Contact plungers        | 5 | Number light contact plate |
| 3 | Negative contact plate  | 6 | Contact plate bracket      |

Fig 20 Rear door connections

**Rectifier unit**

Changing a main fuse

90 The procedure for changing the main fuse in the rectifier unit is as follows:

- 90.1 Put the battery switch (Fig 2(25)) to OFF
- 90.2 Remove the fuse cover, secured by eight screws.
- 90.3 Release the fuse link, secured by two setscrews with plain and spring washers.
- 90.4 Ensure that the contact surfaces are clean and free from burns.
- 90.5 Fit the new fuse link and replace the cover.
- 90.6 Check the charging circuit.

**MAINTENANCE****Suppression of electrical interference to radio services**

91 The use of VHF radio sets calls for a high standard of vehicle suppression if interference is to be effectively suppressed and full advantage of the sets obtained. Good servicing of the electrical system is therefore essential and it must be remembered that although a vehicle is not carrying a radio set, it can cause interference to nearby radio sets. The important points are:

- 91.1 Make sure that there is no intermittent contact on any fuse, switch, or terminal.
- 91.2 Keep all connections and mating surfaces clean and free from paint, corrosion, and lubricant.
- 91.3 Keep all bonding strips and earth braids free from corrosion, paint, or dirt, and ensure that they are properly secured.
- 91.4 Do not paint under bonding strips or other parts intended to be in electrical contact.
- 91.5 Ensure that no cable screening is corroded or frayed and is properly earthed at both ends. Metal-to-metal contacts must be maintained throughout all screened circuits.
- 91.6 Ensure that all components, covers, and brackets are firmly secured.
- 91.7 Do not interfere with the vehicle wiring or make improvised connections.
- 91.8 Do not remove any suppression equipment that may be fitted.
- 91.9 Refrain from using any switch unnecessarily.
- 91.10 Report immediately to REME any defect, which may affect the standard of suppression of the vehicle.

**CHAPTER 2-7**  
**VEHICLE OPERATION**  
**CONTENTS**

Para

1 General  
Starting and driving  
3 Pre-start checks (CAUTION)  
4 Normal starting (CAUTION)(WARNING)  
5 Emergency starting  
6 Starting by using the batteries of another vehicle (CAUTIONS)  
7 Starting by towing (WARNING)(CAUTIONS)  
8 Stopping the engine  
9 Engine emergency stop  
10 Moving off  
11 Changing gear (WARNING)(CAUTION)  
15 Driving up an incline  
16 Steering  
18 Steering/brake levers (WARNING)  
21 Steering linkage lubrication  
23 Stopping the vehicle  
25 Parking  
29 When being towed (WARNING)  
31 Towing and recovery  
32 During towing  
35 During recovery

Table

Page

1 Engine gear ranges ..... 14  
2 Gears and permissible downshift speeds..... 15

Fig

1 Driver's compartment..... 2  
2 Driver's controls and instruments ..... 3  
3 Fuel cock ..... 4  
4 Fan controls and radio distribution box (Mk 2 vehicles) ..... 5  
5 Radio distribution box (Mk 2/1 vehicle)..... 6  
6 Gear range selector ..... 6  
7 Steering and accelerator linkage lubricators ..... 7  
8 Engine/transverse gearbox disconnecter control handle ..... 8  
9 Distribution panel No. 6 Mk1 ..... 9  
10 Driver's switchboard ..... 10  
11 Instrument panel ..... 10  
12 Engine speed hand control ..... 12  
13 Steering lever cross-shaft lubricator ..... 17  
14 Steering brake linkage ..... 17  
15 Rear of vehicle ..... 19  
16 Front of vehicle ..... 20

**GENERAL**

- 1 This chapter provides a reference for basic vehicle operation, containing instructions on the main automotive functions. It is essential that the operator is conversant with the equipment and the contents of the previous chapters, before attempting to start the engine or drive the vehicle.
- 2 Driver's controls, instruments and layout of the driver's compartment are illustrated in figures 1 and 2.

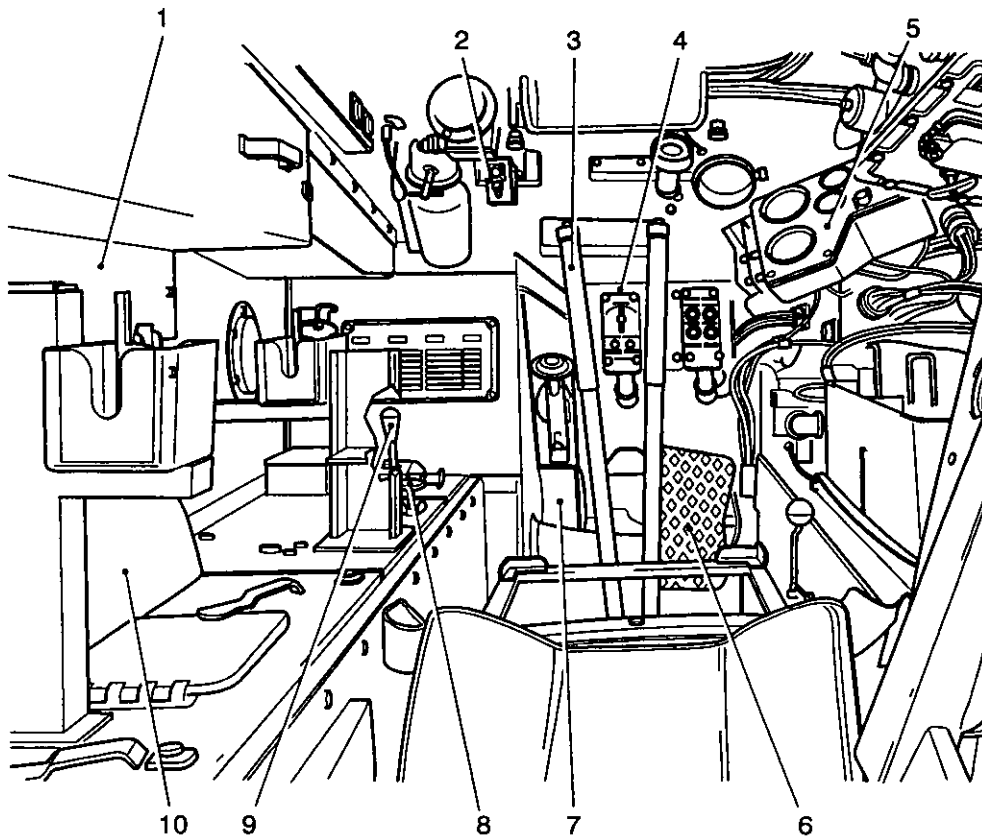

430/20118

- |   |                                       |    |                                       |
|---|---------------------------------------|----|---------------------------------------|
| 1 | Power pack access plate upper section | 6  | Accelerator pedal                     |
| 2 | Wiper/IR sight switch                 | 7  | Engine fuel stop control              |
| 3 | Steering/brake levers                 | 8  | Engine speed hand control             |
| 4 | Driver's switchboard                  | 9  | Gear range selector lever             |
| 5 | Instrument panel                      | 10 | Power pack access plate lower section |

Fig 1 Driver's compartment

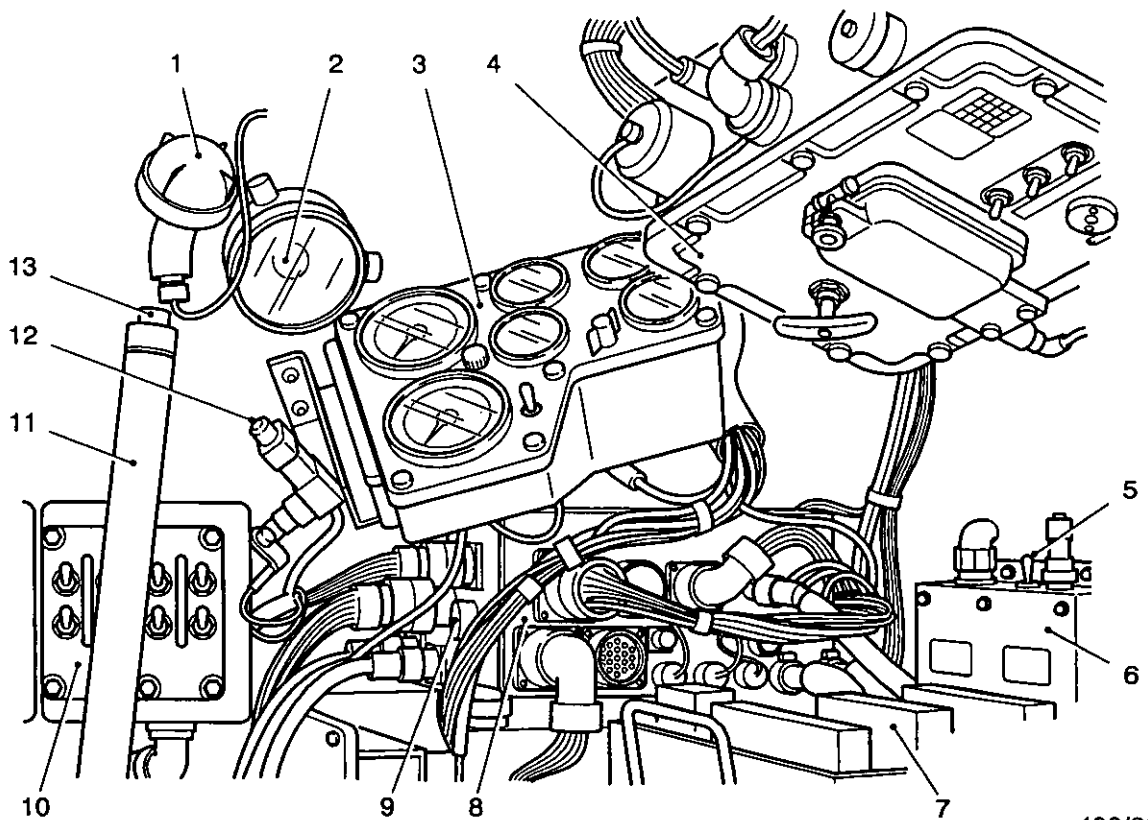

430/20131

- |   |                                  |    |                                     |
|---|----------------------------------|----|-------------------------------------|
| 1 | Fire warning light               | 8  | Distribution link box               |
| 2 | Interior light                   | 9  | Distribution link box warning light |
| 3 | Instrument panel                 | 10 | Driver's switchboard                |
| 4 | Distribution panel               | 11 | Steering/brake lever                |
| 5 | Firewire control box test switch | 12 | Horn push                           |
| 6 | Firewire control box             | 13 | Parking control button              |
| 7 | Automotive batteries             |    |                                     |

Fig 2 Driver's controls and instruments

## STARTING AND DRIVING

### Pre start checks

#### CAUTION

**EQUIPMENT DAMAGE.** If the engine is started with the distribution link box warning light illuminated, internal damage to the generating system will result.

3 To carry out pre start checks, proceed as follows:

3.1 Ensure that all necessary servicing has been completed as required by the Maintenance Schedule, ASEP 2350-T-250-601 refers.

#### NOTE

None of the pre start checks detailed override any of the checks detailed in the Maintenance Schedule Running Checks Before Use, ASEP 2350-T-250-601 refers.

3.2 Check that the fuel cock (Fig 3(5)) is ON.

3.3 Put the radio distribution box battery switch (Fig 4(3) or Fig 5 (4)) to ON. If the radio batteries are disconnected do not put this switch to 'ON'.



3.4 Check that the external charge switch (Fig 4(4)) or (Fig 5(5)) is at OFF and that the GEN warning light (Fig 4(5)) or (Fig 5(6)) glows.

3.5 If the ambient temperature is below zero degrees Celsius, disengage the engine/transverse gearbox disconnector by pushing the control handle (Fig 8(4)) down.

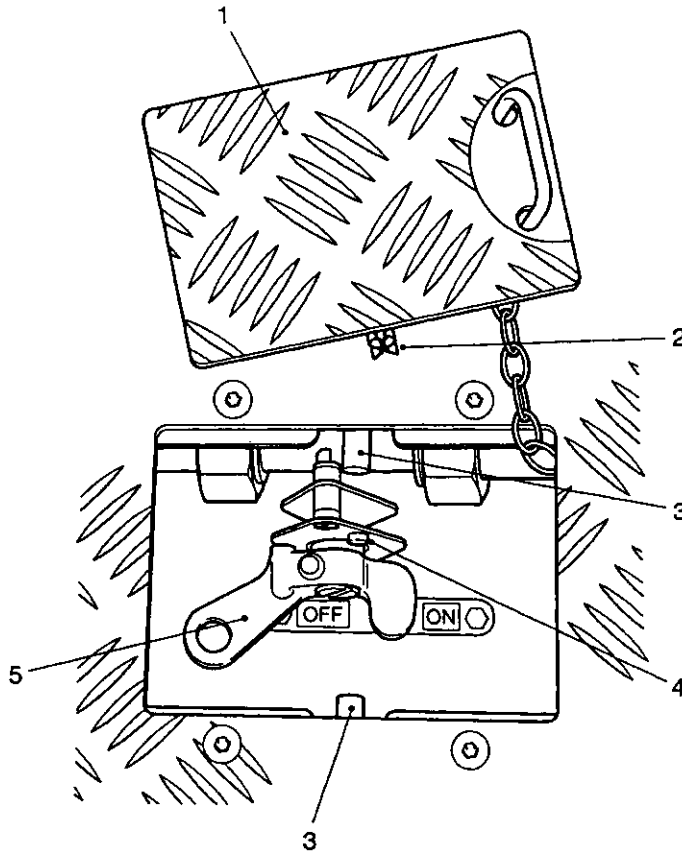

432/101

- |   |                    |   |                  |
|---|--------------------|---|------------------|
| 1 | Cover              | 4 | Stop             |
| 2 | Retaining clip     | 5 | Fuel cock handle |
| 3 | Retaining clip peg |   |                  |

Fig 3 Fuel cock

3.6 Check that the parking brakes are on (Para 25).

3.7 Switch 'ON' the radio and intercommunications and fit headsets (AESP 5800-H-201-Octad)

3.8 Adjust the driver's seat (Chap 2-2 Para 18).

3.9 Adjust the accelerator pedal (Fig 7(1)). Slacken the knurled nut (4) until the toothed washer (3) is free, move the pedal to the required position on the quadrant (2), secure by re-tightening the knurled nut.

3.10 Once the accelerator pedals have been adjusted fit driver's safety harness.

3.11 Adjust the driving mirrors to obtain a clear view, rearwards.

3.12 Check that the gear range selector lever (Fig 6(1)) is at neutral.

3.13 Put the distribution battery switch (Fig 9(2)) to ON and check that the warning light (Fig 2(9)) on the distribution link box does not glow. If it glows, report immediately to REME.

3.14 Put the engine switch to ON (see Fig 10(6)).

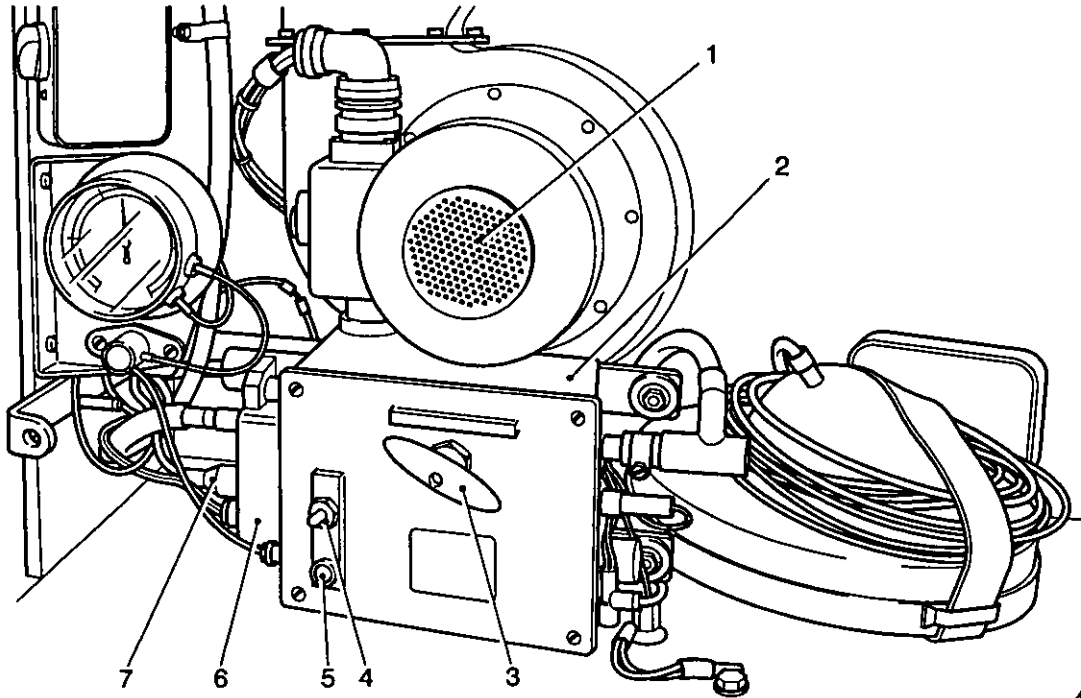

432/079

- |   |                        |   |                   |
|---|------------------------|---|-------------------|
| 1 | Fan motor              | 5 | GEN warning light |
| 2 | Radio distribution box | 6 | Fuse cover        |
| 3 | Battery switch         | 7 | External link     |
| 4 | External charge switch |   |                   |

Fig 4 Fan controls and radio distribution box (Mk 2 vehicles)

3.15 Check that the OIL and GENERATOR warning lights glow (Fig 10) and that the fuel gauge, coolant thermometer and gearbox oil thermometer register (Fig 11). If any of the lights do not glow, test the lamp with the engine switch 'ON'. The light should glow when the lens is pressed. If the lamp glows constantly, the circuit is at fault and must be rectified before proceeding; refer to Table 3 Chap 2-8 of this publication.

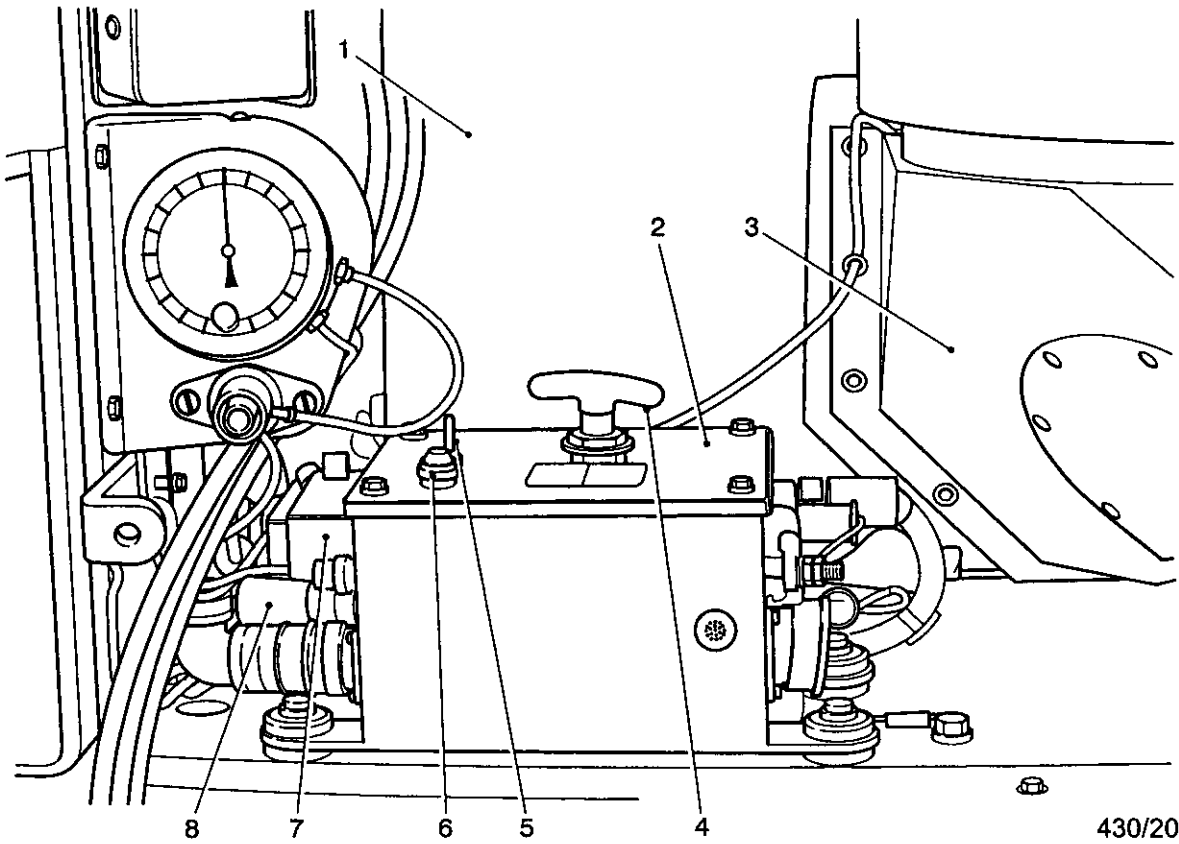

- |   |                                 |   |                         |
|---|---------------------------------|---|-------------------------|
| 1 | Air conditioning filter housing | 5 | External charge switch  |
| 2 | Radio distribution box          | 6 | GENERATOR warning light |
| 3 | Ducting - filter housing to fan | 7 | Fuse cover              |
| 4 | Battery switch                  | 8 | External link           |

Fig 5 Radio distribution box (Mk 2/1 vehicles)

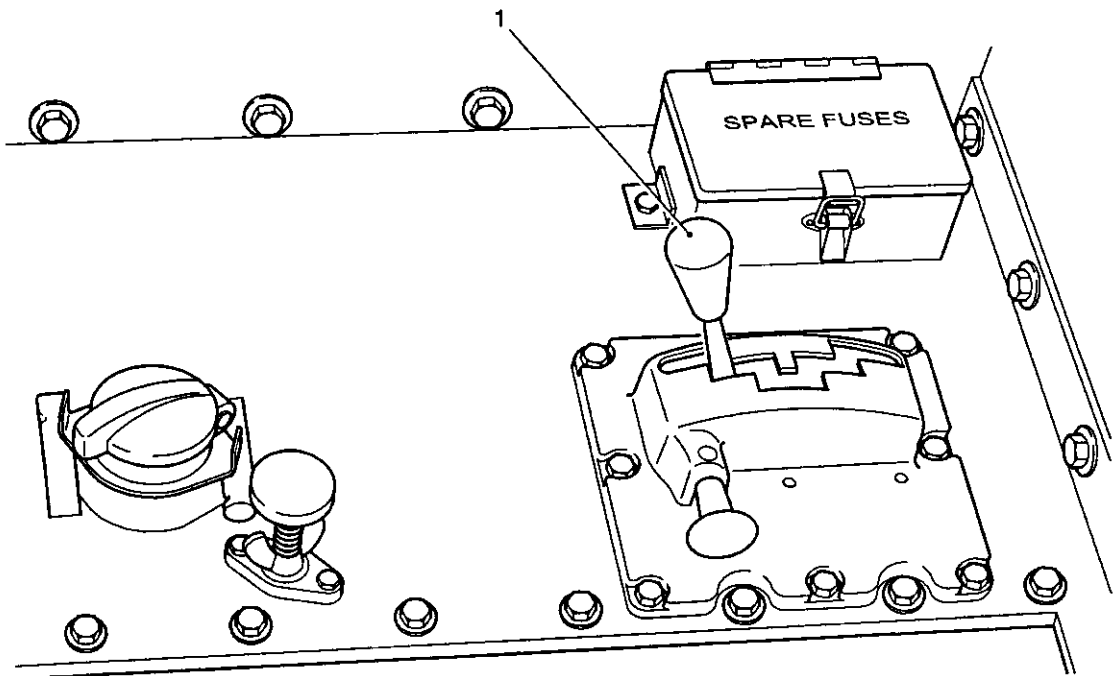

- |   |                           |
|---|---------------------------|
| 1 | Gear range selector lever |
|---|---------------------------|

Fig 6 Gear range selector

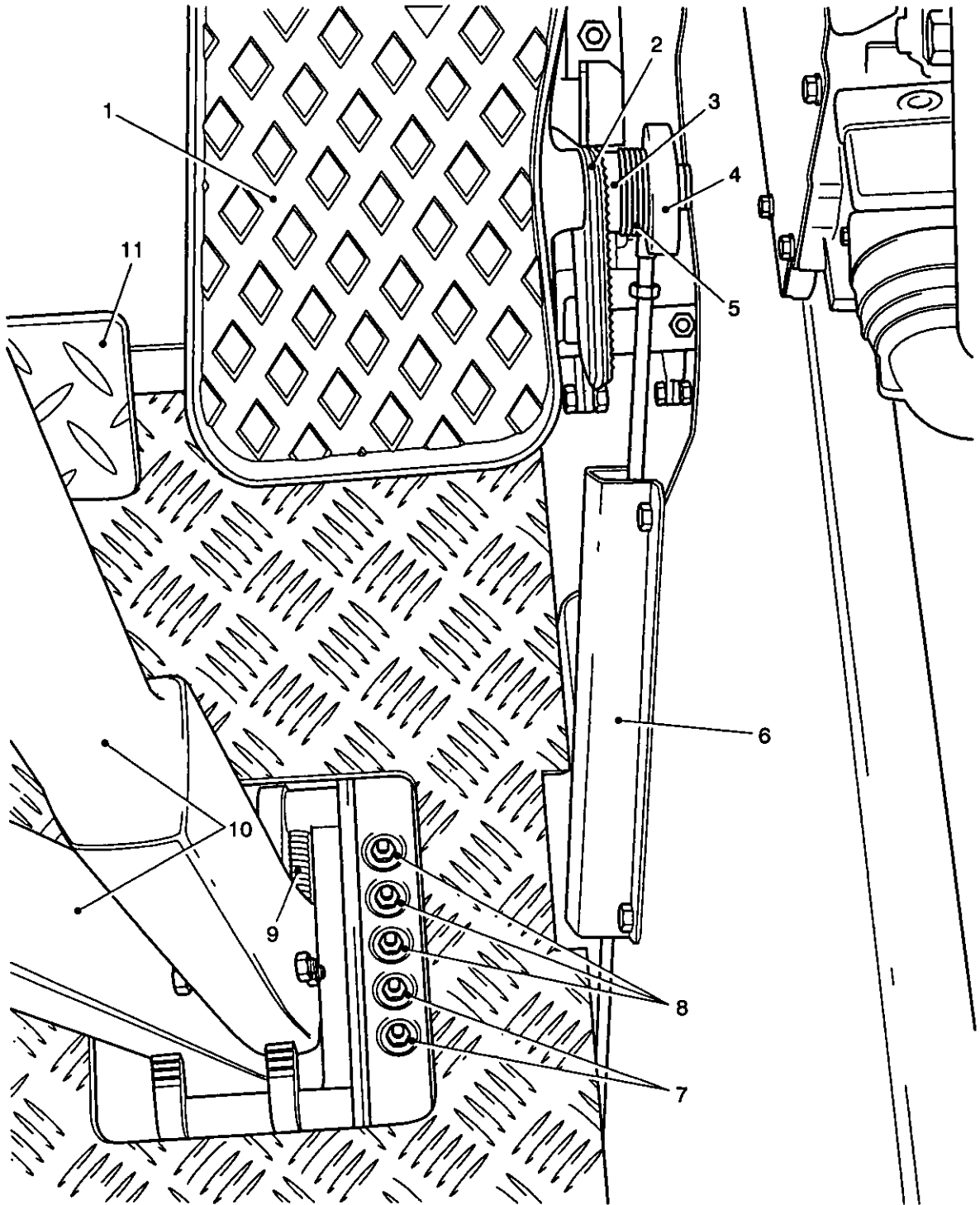

432/061

- |   |                   |    |                                     |
|---|-------------------|----|-------------------------------------|
| 1 | Accelerator pedal | 7  | Accelerator cross-shaft lubricators |
| 2 | Quadrant          | 8  | Steering linkage lubricators        |
| 3 | Toothed washer    | 9  | Steering/brake lever return spring  |
| 4 | Knurled nut       | 10 | Steering/brake levers               |
| 5 | Spring            | 11 | Fuel stop control pedal             |
| 6 | Guard             |    |                                     |

Fig 7 Steering and accelerator linkage lubricators

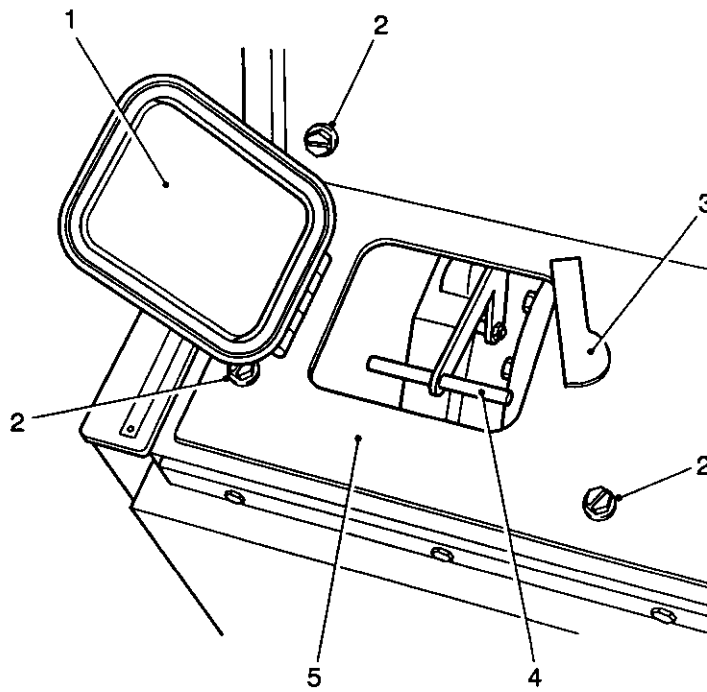

432/048

- |   |            |   |                              |
|---|------------|---|------------------------------|
| 1 | Cover      | 4 | Dis-connector control handle |
| 2 | Turn catch | 5 | Power pack partition plate   |
| 3 | Catch      |   |                              |

Fig 8 Engine/transverse gearbox dis-connector control handle

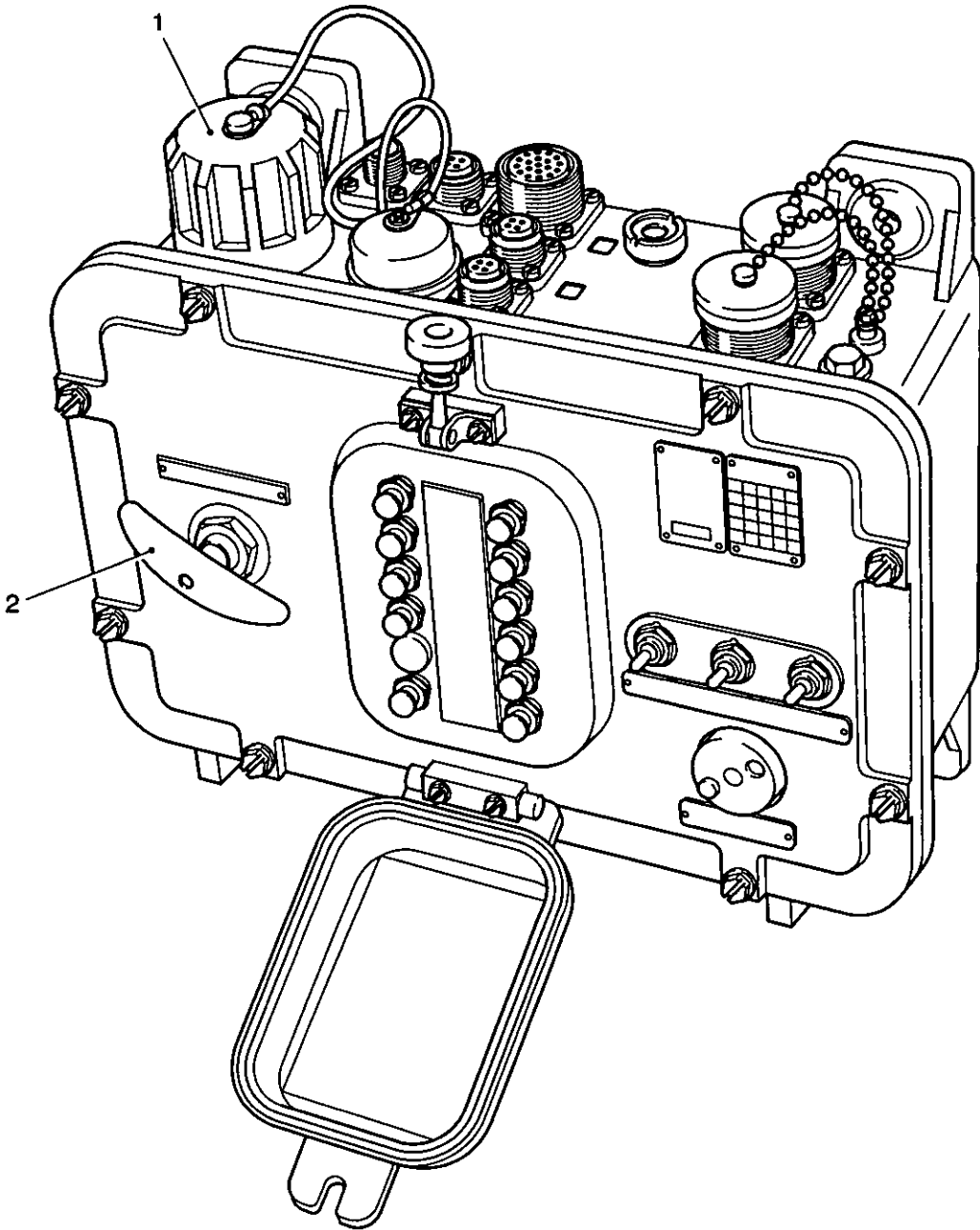

432/041

1 Inter-vehicle starting socket

2 Battery master switch

Fig 9 Distribution panel No. 6, Mk 1

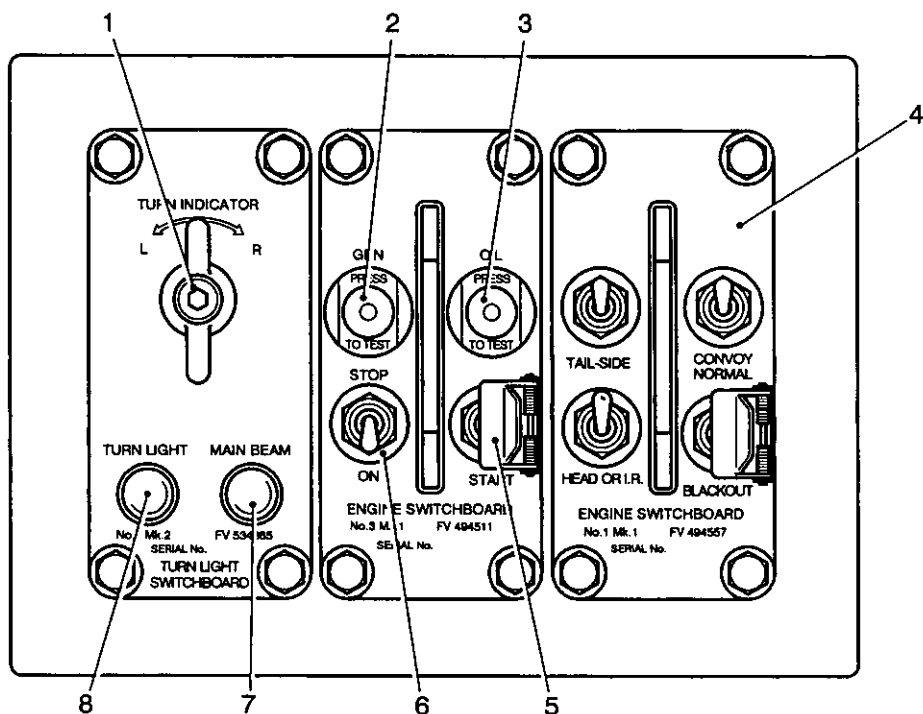

432/456

- |   |                                |   |                          |
|---|--------------------------------|---|--------------------------|
| 1 | Turn light switch              | 5 | Starter switch           |
| 2 | Main indicator (GEN)           | 6 | Engine switch            |
| 3 | Low oil pressure warning light | 7 | Main beam warning light  |
| 4 | External lighting switchboard  | 8 | Turn light warning light |

Fig 10 Driver's switchboard

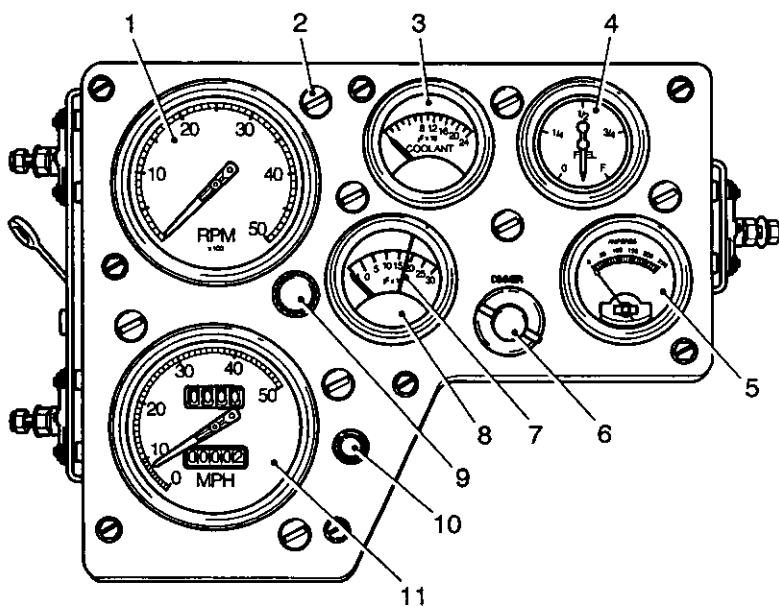

432/085

- |   |                           |    |                                     |
|---|---------------------------|----|-------------------------------------|
| 1 | Tachometer                | 6  | Panel lights switch                 |
| 2 | Panel light               | 7  | Warning temp indicating mark        |
| 3 | Coolant temperature gauge | 8  | Gearbox oil temp gauge              |
| 4 | Fuel gauge                | 9  | Fuse                                |
| 5 | Ammeter                   | 10 | Speedometer trip reading reset knob |
|   |                           | 11 | Speedometer                         |

Fig 11 Instrument panel

## Normal starting

### CAUTION

**EQUIPMENT DAMAGE.** Running the engine for long periods with the engine/transverse gearbox dis-connector clutch out of engagement may damage the clutch.

4 Carry out normal start procedure as follows:

4.1 Carry out the pre check checks (Para 3 refers)

4.2 Fully depress the accelerator pedal (Fig 7(1)), lift the spring-loaded cover (Fig 10(5)) and operate the starter switch, release the starter switch and the accelerator pedal as soon as the engine starts.

4.3 If the engine does not start in five or six seconds, release the switch and pedal, wait ten seconds then try again. Prolonged use of the starter will result in its cutting out due to overheating and the starter will not operate until it cools.

4.4 Check that the OIL and both GEN warning lights (Fig 10(2) and (3) and Fig 4(6) or 5(5)) go out as the engine speed is increased, also check that the warning light on the distribution link box glows dimly. If any fail to do so, stop the engine immediately and report to REME.

### WARNING

**VEHICLE MOVEMENT. THE DRIVER SHOULD NOT LEAVE THE VEHICLE WHEN THE ENGINE IS RUNNING UNLESS THEIR OWN SAFETY IS ENDANGERED.**

### NOTE

Due to wide pressure tolerance, the oil warning light may not go out until the engine speed (Fig 11(1)) is increased to approximately 1000 rev/min.

4.5 Fully apply both steering/brake levers, move the gear range selector to the 3-6 positions, and run the engine at 1000 rev/min as displayed on the rev counter (Fig 11(1)) to bring the engine up to working temperature.

### NOTE

In extreme cold start conditions, disconnect the transverse gearbox start the engine and run for four minutes, then STOP THE ENGINE and re-engage the engine/transverse gearbox using the dis-connector control handle (Fig 8(4)). Re-start the engine.

4.6 When coolant temperature reaches, 90.5 to 93.3 deg C (195 to 200 deg F) select neutral and adjust idling speed to 800 rev/min (tachometer) using the engine hand speed control (Fig 12).

4.7 Check the coolant temperature (Fig 11(3)) at frequent intervals while the engine is running. The coolant operating temperature will vary according to operating conditions but, in areas where normal ambient temperatures prevail (i.e. Europe), the maximum temperature should not exceed 94 deg C (200 deg F). Where high ambient temperatures are encountered, REME advice should be obtained and the coolant temperature must never be allowed to exceed 105 deg C (220 deg F).

### NOTE

To keep the radio batteries fully charged the radio battery switch must be kept in the ON position whenever the engine is running.

*Delete*

## Emergency starting

5 If the automotive batteries are in such low state of charge that they cannot operate the starter motor efficiently, a slave battery carrier or batteries of a similar capacity on another vehicle can be used to start the engine.



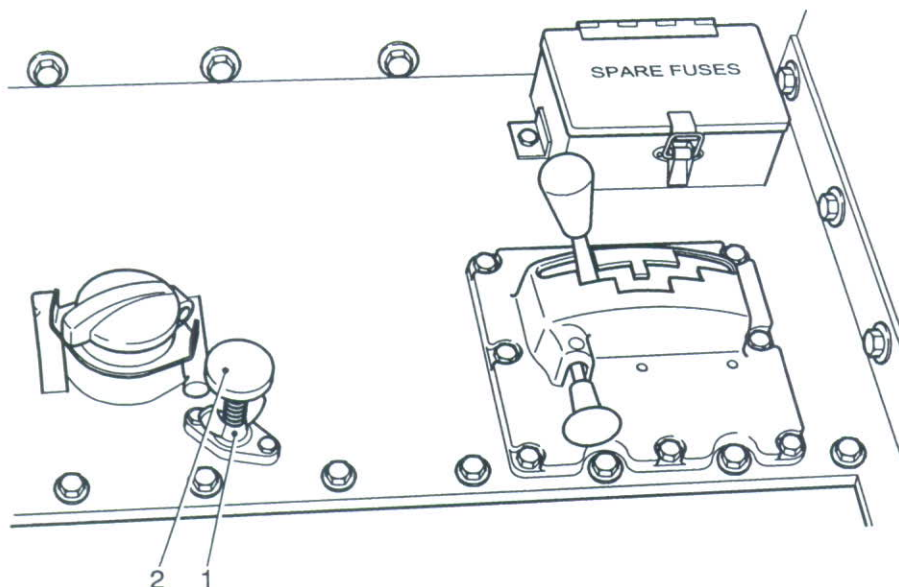

432/087a

1 Wing Nut

2 Engine speed hand control

Fig 12 Engine Speed Hand Control

Starting by using the batteries of another vehicle**CAUTION**

**EQUIPMENT DAMAGE.** The engine must not be run with the automotive batteries disconnected.

- 6 If engine starting is unsuccessful due to discharged vehicle batteries, proceed as follows;
  - 6.1 Position the donor vehicle so that the inter-vehicle cable can be plugged into both inter-vehicle sockets (Fig 9(1)).
  - 6.2 Disconnect the transfer gearbox dis-connector lever. (Refer to Note at Para 4.5)
  - 6.3 Ensure that the battery switches of the vehicles are turned to the 'OFF' position.
  - 6.4 Remove the protection cap (Fig 9(1)) from the inter-vehicle starting socket on each vehicle and connect the inter vehicle cable to the inter vehicle socket of each vehicle.
  - 6.5 Turn the battery switches, to the 'ON' position, then start and run the engine of the donor vehicle at fast idling speed (approx 1000 rev/min).
  - 6.6 Attempt to start the vehicle.
  - 6.7 When the engine has started and running smoothly (or if the engine fails to start), stop the engine of the donor vehicle and set the 'Battery Master' switch of the donor vehicle to 'OFF'
  - 6.8 Dis-connect the inter-vehicle cable, firstly from the recipient vehicle and then the donor vehicle. Replace the socket caps and stow the cable.
  - 6.9 Re-engage the transfer gearbox dis-connector lever.

**CAUTION**

**Do not re-engage transfer gearbox whilst engine is running as serious equipment damage could occur.**

6.10 If the engine fails to start, refer to the failure diagnosis tales in Chap 2-8 of this publication.

Starting by towing

**WARNING**

**PERSONNEL INJURY. WHEN TOW STARTING WITH A CHAIN, WIRE ROPE OR KINETIC ENERGY ROPE, BOTH DRIVER AND COMMANDER MUST BE CLOSED DOWN. ONCE THE VEHICLE HAS STARTED, THE VEHICLE IS TO BE HALTED IN A SAFE PLACE AND THE TOWING EQUIPMENT DISCONNECTED**

**CAUTIONS**

- (1) **EQUIPMENT DAMAGE.** The engine must not be run with the automotive batteries disconnected.
- (2) **EQUIPMENT DAMAGE.** The 'towed/dead' vehicle must be towed in as near a straight line as possible.
- (3) **EQUIPMENT DAMAGE.** When the engine of the 'towed/dead' vehicle starts, stop both vehicles immediately and dis-connect the tow equipment.
- (4) **EQUIPMENT DAMAGE.** If using chains or ropes to tow start a vehicle, and drivers have to baton down, the 'towed/dead' vehicle and the towing vehicle must have inter-vehicle communications.

7 To start the engine by towing proceed as follows;

- 7.1 Position the towing vehicle and connect the towing ropes (diagonally crossed) or 'A' Frame (Hollebones).
- 7.2 Ensure that the towing vehicle is in the lowest forward gear.
- 7.3 Put the battery switches and the engine switch to 'ON'.

**NOTE**

If the radio batteries are disconnected, do not put the radio battery switch to 'ON'.

- 7.4 Put the gear range selector lever to neutral.
- 7.5 Release the brakes on the towed vehicle and commence towing.
- 7.6 When the vehicle attains a speed of 16 km/h (10 mph), engage 3-4 range and when the engine starts, signal the towing vehicle to stop immediately, return the gear range selector lever to neutral and apply the vehicle brakes. Keep the engine running at approximately 1000 rev/min until it is warmed up and running satisfactorily. Check that the warning generator lights go out.
- 7.7 Remove the towing gear.

**Stopping the engine**

8 To stop the engine proceed as follows;

- 8.1 With the vehicle in neutral, and the steering/brake tillers applied, slacken the wing nut (Fig 12(1)) on the engine speed hand control (2) and turn the knurled head of the screw to increase the engine speed to 1000 rev/min, run the engine at this speed for a minimum of 3 minutes, or until the coolant temperature drops to 185 deg F, whichever is the longer period.
- 8.2 Reset the engine speed with the hand control to 800 rev/min, tighten wing nut.

## 8.3 Switch off the engine (Fig 10(6)).

**Engine emergency stop**

9 In the event of a fault, which causes the engine to 'run away', depress the engine fuel stop control pedal (Fig 7(11)). Report to REME immediately, the vehicle will be classified as VOR (Vehicle Off Road) until it is repaired.

**Moving off**

10 To move off proceed as follows;

10.1 The prevailing driving conditions must determine the gears to be used and these selected by the position of the gear range selector lever.

**NOTE**

When driving on public roads, ensure that the amber rotating beacon is switched ON to warn other road users of a slow moving vehicle.

10.2 Position the gear range selector lever in the required range; see Table 1.

**NOTE**

To engage reverse gear, pull the knob on the side of the selector lever bracket, move the lever to the position marked 'R' and release the knob.

10.3 Release the parking brake controls by pulling back on the steering/brake levers.

10.4 Allow the steering/brake levers to move to the forward position.

10.5 Gradually accelerate the engine speed by depressing the accelerator pedal (Fig 7(1)). As the engine speed increases, the drive will be taken up and the vehicle will move off smoothly, the gears changing automatically within the range selected to suit engine conditions. To decrease the engine speed release the accelerator pedal.

**TABLE 1 ENGINE GEAR RANGES.**

Condition	Gear range	
	Road	Cross country
Light traffic	3-6	-
Fairly heavy traffic	3-5	-
Heavy traffic	3-4	-
Light ground	-	3-5
Heavy ground	-	3-4
Speeds below 8 kph (5 mph)	1-2	1-2
Manoeuvring in confined space	1-2	1-2
Steep gradient (ascending or descending)	1-2	1-2
Undulating terrain	3-5	3-5
Reversing	R	R

## Changing gear

### WARNING

**ROAD SAFETY HAZARD. DEPRESSING THE ACCELERATOR FULLY TOO RAPIDLY CAN CAUSE A DOWN CHANGE AND RELEASING IT QUICKLY, AN UP CHANGE. THE CONTINUAL EMPLOYMENT OF THIS TYPE OF DRIVING AND CAN BE DANGEROUS WHEN DRIVING IN TRAFFIC.**

### CAUTION

**EQUIPMENT DAMAGE. Serious damage can be caused to the gearbox if downshifts are made manually when the vehicle is travelling at speeds exceeding those given in Table 2 below.**

11 Up and down gear changes are made automatically in the gearbox, within the range selected, to suit engine conditions. Incorrect operation of the accelerator pedal can, however, create abnormal conditions, which cause automatic changes to occur more frequently than conditions necessitate. Depressing the accelerator fully too rapidly can cause a down change and releasing it quickly, an up change. The continual employment of this type of driving can result in damage to the gearbox and can be dangerous when driving in traffic.

12 Always endeavour to operate the accelerator with a firm, steady movement as when driving a vehicle fitted with a manually operated gear change mechanism.

**TABLE 2 GEARS AND PERMISSIBLE DOWNSHIFT SPEEDS.**

Gear range		Maximum permissible downshift speed
From	To	
3-6	3-5	35 km/h (22 mph)
3-5	3-4	25 km/h (16 mph)
3-4	1-2	13 km/h (8 mph)

13 Before descending a steep hill, use the brakes to slow the vehicle speed, select the appropriate gear range as defined in table 1. Descend the hill using the accelerator pedal to adjust engine speed and use the brakes intermittently to control the speed of the vehicle.

14 Before attempting to engage reverse gear, stop the vehicle.

### Driving up an incline

15 To prevent crankcase pressurization it has been found necessary to re-introduce an open type breather on the K60 engine. When driving up an incline the following advise is given to users to avoid oil spillage from the crankcase breather:

15.1 DO NOT exceed an engine speed of 3000 rev/min when driving up a 1 in 3 (18½ deg) slope.

15.2 DO NOT exceed an engine speed of 2000 rev/min when driving up a 1 in 2 (26½ deg) slope.

### NOTE

There is NO restriction on engine speed for slopes less than 1 in 3.

### Steering

16 The steering unit directs the power from the pack to the left and right sides of the vehicle through a crown wheel and pinion.

17 The unit contains a spur gear differential, which can be controlled by adjustable brakes, which when applied individually, varies the speed of the outputs thus causing the vehicle to steer.

**Steering/brake levers****WARNINGS**

- (1) EQUIPMENT DAMAGE. PROLONGED APPLICATION OF THE STEERING/BRAKE LEVERS COULD LEAD TO OVERHEATING OF THE STEERING/BRAKE SYSTEM, WHICH COULD CAUSE PREMATURE FAILURE.**
- (2) SAFETY HAZARD. IF THE ADJUSTMENT DESCRIBED IN PARA 20 IS INCORRECT THE FAULT MUST BE REPORTED TO REME IMMEDIATELY.**

18 The vehicle is steered by pulling back on the relevant steering/brake levers (Fig 1(3)). The left tiller will turn the vehicle left and right tiller will turn the vehicle right, which will apply the brake band in the steering unit. Continuous application of the steering levers, during normal driving, could cause the steering drum to overheat. This could cause damage to both the brake drum and brake bands, therefore when it is intended to turn the vehicle it should be steered by pulling hard on the relevant tiller (left or right) and then releasing (i.e. turning a corner should be done in a series of arcs). Whilst manoeuvring or negotiating tight turns the steering lever is to be applied fully and then released when the manoeuvre is complete. Engine speed is to be increased to provide sufficient power to complete the manoeuvre. When both steering/brake levers are applied simultaneously the vehicle can be slowed, stopped or parked.

19 The normal movement of the levers at the handles should be approx 150 mm (6 in.).

20 From a safety point view, it is essential to check the balance of the brakes by ensuring that the levers have an equal travel and that this amount is not excessive. If the movement is less than 150 mm (6 in.), greater than 200 mm (8 in.), or if the pair of levers has unequal movement, report to REME. For further information refer to AC64193, Warning card for Steering and Braking.

**NOTE**

The distances described in Para 20 relate to the application of the brake/steering levers being applied and measured forward towards the hull.

**Steering linkage lubrication**

21 The steering lever cross-shafts are lubricated through four lubricating nipples, the three forward nipples (Fig 7(8)) on the row of five located in the driver's compartment to the right of the steering/brake levers and the fourth nipple (Fig 13(1)) on the main cross-shaft sleeve which is accessible when the steering unit access plate is open.

22 Each steering unit brake-operating shaft has a lubricating nipple (Fig 14(4)) on the inner end face. The fork end connecting pins and rollers (5) must be oilcan lubricated.

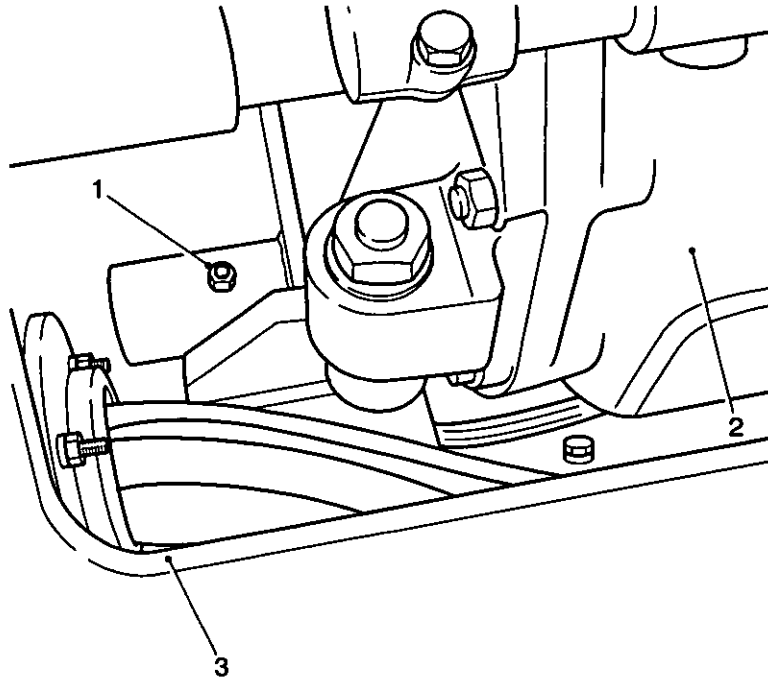

432/073

- |   |                    |   |                           |
|---|--------------------|---|---------------------------|
| 1 | Lubricating nipple | 2 | Steering unit access sill |
| 2 | Steering unit      |   |                           |

Fig 13 Steering lever cross-shaft lubricator

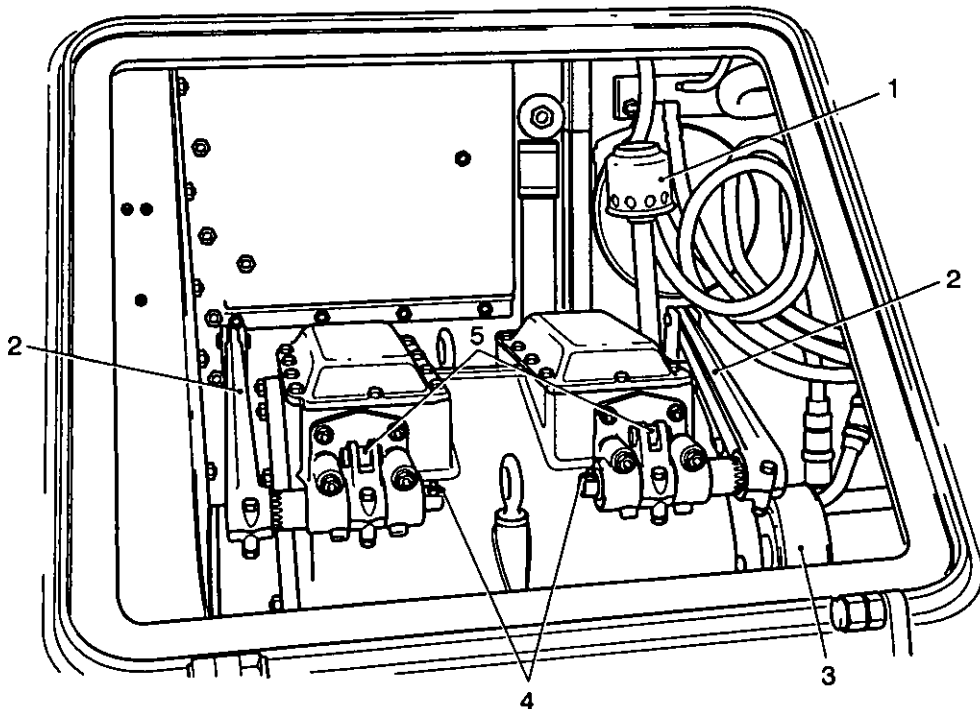

432/072

- |   |                        |   |             |
|---|------------------------|---|-------------|
| 1 | Steering unit breather | 4 | Lubricators |
| 2 | Brake operating lever  | 5 | Rollers     |
| 3 | Half shaft coupling    |   |             |

Fig 14 Steering brake linkage

**Stopping the vehicle**

23 Release the accelerator pedal and apply the brakes by pulling back both steering/brake levers (Fig 2(12)) simultaneously; apply and release the brakes intermittently until the vehicle is stopped. Simultaneous operation of both levers causes the vehicle to slow down and the stoplights to come on, while greater pressure sustained on the levers causes the vehicle to stop. Only when essential, as in an emergency, should the levers be held continually.

24 If the vehicle is to remain stationary with the engine running, fully apply the brakes by pulling both steering/brake levers simultaneously rearwards and engage the parking controls (Fig 2(14)) in the top of each lever. Put the gear range selector lever to neutral.

**Parking**

25 Stop the vehicle, apply the brakes to the hard on position and engage the parking controls in the top of each lever. The levers are locked in the on position, when parking, by means of the pawl and ratchet mechanism, after depressing the plungers. A slight backward movement given to the levers causes the pawls to be released by the reaction of the plunger return springs. Whenever possible, park the vehicle on level ground. If sloping ground is unavoidable, position the vehicle across the slope. Scotch the road wheels using scotch blocks (AESP 2350-T-250-741).

26 Switch 'OFF' the engine (Para 8).

27 Put the automotive battery switch to 'OFF' (Fig 9(2)).

28 Put the radio battery switch to 'OFF' (Fig 4 (3) or Fig 5 (4)).

**When being towed****WARNING**

**PERSONAL INJURY. WHEN TOWING WITH A CHAIN, WIRE ROPE OR KINETIC ENERGY ROPE, BOTH DRIVER AND COMMANDER'S HATCHES MUST BE CLOSED DOWN.**

29 In an emergency the vehicle may be towed forward up to half a mile without too serious a risk of causing damage. The vehicle must never be towed in reverse. Like or other FV430 series vehicles can be used for towing, using the tow ropes of both vehicles, with the ropes crossed diagonally and connected to the towing eyes (Fig 15(1) and Fig 16(1)).

30 If towing for a greater distance, or if the brakes are inoperative, await for instructions from REME.

**NOTE**

The maximum towing speed must not exceed 16 kph (10 mph).

**Towing and recovery**

31 It may be necessary for the vehicle to be used for towing and recovery of other FV430 series vehicles in the absence of a recovery vehicle. If this situation does arise, the following points must be observed.

During towing

32 Gear range selector 1-2 or 3-4 when appropriate.

33	Speeds:	Cross country	8 km/h	(5 mph)	(maximum)
		Road	16 km/h	(10 mph)	(maximum)

34 Gearbox temperature must not exceed 121 deg C (250 deg F).

During recovery

- 35 Gear range selection 1-2 only.
- 36 Speed limited to 3 to 5 km/h (2 to 3 mph).
- 37 Gearbox temperature must not exceed 121 deg C (250 deg F).

NOTE

It is probable that recovery will be limited by track slip or excessive gearbox temperature.

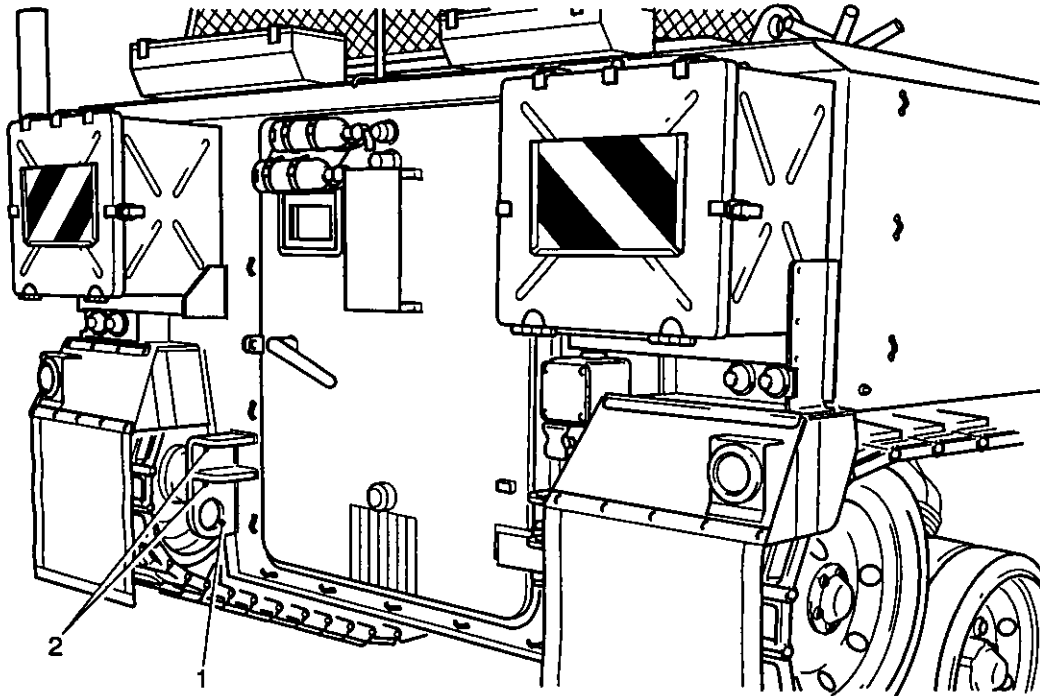

432/021a

1 Towing eye

2 Tow bar bracket

Fig 15 Rear of vehicle



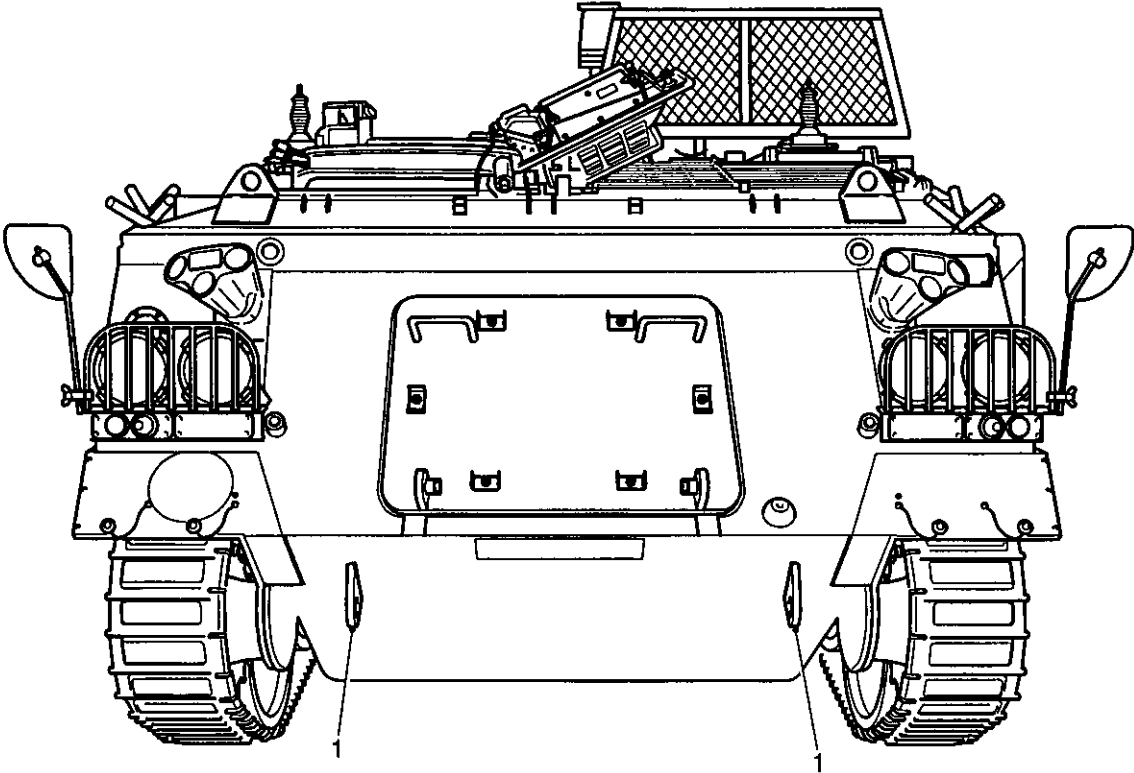

430/20132

- 1 Towing eyes

Fig 16 Front of vehicle

CHAPTER 2-8  
FAILURE DIAGNOSIS  
CONTENTS

Para

- 1 General
- 2 Fire alarm system
- 3 Engine
- 4 Starting circuit
- 5 Charging circuit
- 6 Driving lights and horn
- 7 Engine auxiliaries
- 8 Auxiliaries

Table

Page

1	Fire alarm system- failure diagnosis .....	1
2	Engine - failure diagnosis .....	2
3	Starting circuit - failure diagnosis .....	4
4	Charging circuit - failure diagnosis .....	4
5	Driving lights and horn - failure diagnosis .....	5
6	Engine auxiliaries - failure diagnosis .....	6
7	Auxiliaries - failure diagnosis .....	6

**GENERAL**

1 This chapter details the operator actions, which can be taken to isolate and rectify failures to equipments and systems during vehicle operations. It is assumed that all routine servicing tasks (Category 601 of the Variant Octad) and all operating procedures (Chap 2-7) have been carried out correctly.

**FIRE ALARM SYSTEM**

2 If the fire alarm system fails to operate correctly, proceed as detailed in Table 1.

**TABLE 1 FIRE ALARM SYSTEM - FAILURE DIAGNOSIS**

Serial (1)	Symptoms (2)	Probable causes (3)	Action (4)
1	No warnings when test switch is operated (other circuits satisfactory)	Check Circuit Breakers C and J in Distribution panel No. 6 Mk 1 Check security of harnesses throughout system	Report to REME Report to REME
2	No buzz in a connected headset, horn sounds	Fit another headset Check that the intercom is switched on	Report to REME Report to REME
3	Warnings continue when test switch is released		Proceed as detailed in Chap 2-1

(continued)

**TABLE 1 FIRE ALARM SYSTEM FAILURE - DIAGNOSIS (continued)**

Serial (1)	Symptoms (2)	Probable causes (3)	Action (4)
4	Lights do not flash when test switch is operated, horn sounds	Circuit Breaker C Check lamps Check security of harnesses throughout system Flasher unit possibly faulty	Report to REME Report to REME Report to REME Report to REME
5	Horn does not sound, lights flash	Check horn connections	Report to REME

**ENGINE**

3 The engine fails to operate correctly, proceed as detailed in Table 2.

**TABLE 2 ENGINE - FAILURE DIAGNOSIS**

Serial (1)	Symptoms (2)	Probable causes (3)	Action (4)
1	Engine fails to start		Check starting circuit (Table 3 refers).
2	Engine will not fire.	Air in the fuel system Pipe connections loose No fuel at injectors No fuel at injectors Choked feed pipes Loose connections in pipe runs Faulty electric fuel pump or dirty fuel filter Fuel filters obstructed Air cleaner obstructed Fuel injection pump timing incorrect Faulty injection pump	Report to REME Report to REME Check fuel in tank. Check cock is turned on Report to REME Report to REME Report to REME Renew filter elements Clean the air cleaner Report to REME Report to REME
3	Engine fails to pick up	Faulty fuel supply Air cleaner obstructed Faulty fuel injectors	Report to REME Clean the air cleaner Report to REME
4	Engine misfires	Air in the fuel system Fractured injector pipe Faulty injector Faulty fuel injector pump	Report to REME Report to REME Report to REME Report to REME
5	Low oil pressure (relatively sudden pressure drop compared with progressive drop due to worn bearings)	Low oil level Air filters choked Faulty relief valve Faulty oil pressure switch Oil temperature high	Check and fill up Change filter elements Report to REME Report to REME See Serial 6

(continued)

**TABLE 2 ENGINE - FAILURE DIAGNOSIS (continued)**

Serial (1)	Symptoms (2)	Probable causes (3)	Action (4)
6	Engine overheats	Loss of coolant  Obstructed air passages and radiator matrix  Fouled coolant system  Faulty thermostat Fuel injection pump timing incorrect	Check coolant level and drain cock. Check for leaks  Clear air passages and matrix  Drain. Clean and refill system with correct coolant Report to REME Report to REME
7	Low power	Fuel injection pump timing incorrect Faulty injectors Air cleaner obstructed Seized air scavenge blower rotors	Report to REME Report to REME Clean air cleaner Report to REME
8	Low fuel pressure	Faulty fuel pump Leak in fuel suction line  Fuel filter obstructed	Report to REME Check for loose connections or fouling Clean filter element
9	Black smoke from exhaust	Air cleaner obstructed Fuel pump timing incorrect Seized air scavenge blower rotors Over fuelling	Clean air cleaner Report to REME Report to REME If Max. Fuel stop has been damaged, report to REME

**STARTING CIRCUIT**

4 Vehicle fails to start, proceed as detailed in Table 3.

**TABLE 3 STARTING CIRCUIT - FAILURE DIAGNOSIS**

Serial (1)	Symptoms (2)	Probable causes (3)	Action (4)
1	GEN and OIL warning lights fail to glow when engine switch is put to ON	Incorrect switches made  Popped Circuit Breaker  Loose battery connection	Check that the automotive battery switch is ON  Check Circuit Breakers K and M in Distribution panel No. 6 Mk 1 Check battery connections  (continued)

**TABLE 3 STARTING CIRCUIT - FAILURE DIAGNOSIS (continued)**

<b>Serial (1)</b>	<b>Symptoms (2)</b>	<b>Probable causes (3)</b>	<b>Action (4)</b>
2	Starter fails to rotate when starter switch is operated	Gear range selector level in incorrect position Loose battery connection  Low battery charge  Popped Circuit Breaker	Check that gear range selector lever is in neutral Check battery connections Check that the batteries are not discharged Check Circuit Breaker in Distribution link box, adjacent to 'press to test' light
3	Starter not rotating fast enough	Low battery charge  Loose battery connection	Check that the batteries are not partially discharged (Warning lights go dim) Check battery connections
4	Starter rotates but not the engine		Report to REME

**CHARGING CIRCUIT**

- 5 The charging circuit fails to operate correctly, proceed as detailed in Table 4.

**TABLE 4 CHARGING CIRCUIT - FAILURE DIAGNOSIS**

<b>Serial (1)</b>	<b>Symptoms (2)</b>	<b>Probable causes (3)</b>	<b>Action (4)</b>
1	GEN warning light fails to glow when eng switch is put to ON	Incorrect switches made Lamp broken Loose connection	See Table 3 Replace lamp Report to REME
2	Ammeter reading zero and warning lights remain ON	Main fuse in rectifier unit blown Loose connection	Report to REME Check security of cable harnesses in combined charging circuits, i.e. rectifier unit, power pack junction, Distribution link box
3	Warning lights remain ON ammeter showing charge.	Faulty relay in Distribution panel	Report to REME
4	Warning light goes out, ammeter does not show charge	Faulty ammeter	Report to REME
5	Low charging rate (batteries gradually become discharged)		Report to REME

(continued)

**TABLE 4 CHARGING CIRCUIT - FAILURE DIAGNOSIS (continued)**

Serial (1)	Symptoms (2)	Probable causes (3)	Action (4)
6	High charging rate (lights excessively bright when engine is running)		Report to REME

**DRIVING LIGHTS AND HORN**

6 Faults on driving lights and horn proceed as detailed in Table 5.

**TABLE 5 DRIVING LIGHTS AND HORN - FAILURE DIAGNOSIS**

Serial (1)	Symptoms (2)	Probable causes (3)	Action (4)
1	No lights on when distribution battery switch and lighting switches are ON	Popped Circuit Breaker Loose battery connection Loose connection	Check Circuit Breaker B in Distribution panel No. 6 Mk 1 Check the automotive battery connections Check security of the connecting harnesses at the Distribution panel and switchboard
2	Rear turn lights not operating	Loose connection	Check connection at trailer relay
3	Turn lights warning light not operating correctly	Broken lamp	Check the front and rear turn light lamps
4	Stop lights not operating correctly	Incorrect switches made	Check the action of the switches operated by the steering/brake levers
5	Individual lights not working correctly	Blown lamp	Check the lamp
6	Horn not working correctly	Popped Circuit Breaker Loose connection	Check Circuit Breaker B in Distribution panel No. 6, Mk 1 Check connections

**NOTE**

For Serial 2, 3, and 4 in Table 5, the following should also be checked. Check that the blackout and convoy switches are both OFF. The lights are inoperative if the gear range selector lever is in the neutral position and check the action of selector lever switch.

**ENGINE AUXILIARIES**

7 Faults on engine auxiliaries proceed as detailed in Table 6.

**TABLE 6 ENGINE AUXILIARIES - FAILURE DIAGNOSIS**

Serial (1)	Symptoms (2)	Probable causes (3)	Action (4)
1	Engine auxiliaries fail to function when the engine switch is ON	Popped Circuit Breaker  Loose connection	Check Circuit Breakers K and M in Distribution panel No. 6 Mk 1 Check security of the connecting harnesses at the Distribution panel and switchboard
2	Oil pressure warning light not working	Blown lamp	Check the warning lamp
3	Instruments not working.		Report.
4	Instrument panel lights not working	Blown fuse  Blown lamp Dimmer switch	Check fuse in instrument panel Check lamps Check that the dimmer switch is ON

**AUXILIARIES**

8 Faults with the auxiliary systems proceed as detailed in Table 7.

**TABLE 7 AUXILIARIES - FAILURE DIAGNOSIS**

Serial (1)	Symptoms (2)	Probable causes (3)	Action (4)
1	Interior lights not working correctly	Incorrect switches made  Popped Circuit Breaker	Check that switch No. 2 on auxiliary junction box is ON Circuit Breaker A in Distribution panel No. 6 Mk 1
2	Driver's lights and two lights in personnel compartment not working correctly	Blown fuse  Loose connection.	Check fuse F2 in auxiliary junction box Check security of appropriate cable harness (plug 5 on auxiliary junction box)

(continued)

**TABLE 7 AUXILIARIES - FAILURE DIAGNOSIS (continued)**

Serial (1)	Symptoms (2)	Probable causes (3)	Action (4)
3	Commander's and two lights in personnel compartment not working correctly	Blown fuse  Loose connection	Check fuse F4 in auxiliary junction box  Check security of appropriate cable harness (plug 6 on auxiliary junction box)
4	Individual lights not working correctly	Blown lamp	Check lamp
5	Exterior lights not working correctly	Incorrect switches made  Loose connection  Loose connection  Popped Circuit Breaker	Check that the EXT LIGHTING switch on accessories control box or on Distribution panel No. 6 Mk 1, is ON  Check the ventilation batteries and connections  Check security of cable harness (socket 7 on accessories control box or socket 17 on Distribution panel No. 6 Mk 1)  Check Circuit Breaker F in Distribution panel No. 6 Mk 1
6	Ventilation fan not working correctly.	Incorrect switches made  Blown fuse  Loose battery connections.  Low battery	Check that the fan switch on accessories control box or on Distribution panel No. 6 Mk 1, is ON  Check FAN fuse 1 in accessories control box or Circuit Breaker G  Check ventilation battery connection particularly the earth connection  Check that the ventilation batteries are not discharged
7	Smoke dischargers not working correctly	Popped Circuit Breaker  Loose connection.	Check Circuit Breaker A in Distribution panel No. 6 Mk 1.  Check grenade connections.

(continued)



TABLE 7 AUXILIARIES - FAILURE DIAGNOSIS (continued)

Serial (1)	Symptoms (2)	Probable causes (3)	Action (4)
8	Periscope wiper not working correctly	Loose connection  Popped Circuit Breaker	Check that harness is plugged into suppressor unit Check Circuit Breaker A in Distribution panel No. 6 Mk 1
9	Boiling vessel not working correctly	No power  Loose connection	Check that alternators are charging (warning light out, ammeter registering) Check that plug of vessel is correctly inserted in socket
10	Rotating beacon not working – no other lights operating		Proceed as Table 5 Serial 1
11	Rotating beacon not working – all other lights operating	Loose connection  Broken lamp Beacon assembly faulty	Check that plug of beacon is correctly inserted in fascine lighting socket Check the lamp Report to REME
12	Boiling vessel fails to heat up	Cable not connected correctly  Battery master switch not switched ON  Engine is not running. Boiling vessel can only operate when the alternators are on line Engine running, ammeter not registering Engine is not running. Boiling vessel can only operate when the alternators are on line	Ensure connections at both ends of cable are correctly made Ensure battery master switch is switched ON Start engine  Report to REME Start engine

**CHAPTER 3-0**  
**SPECIAL TO ROLE EQUIPMENT**  
**CONTENTS**

**Para**

- 1 List of chapters
- 2 General information

**LIST OF CHAPTERS**

- 1 This chapter is further sub-divided as follows:

**Chap**

- 3-1 Portable shelter
- 3-2 Command role
- 3-3 Ambulance role
- 3-4 Mortar role
- 3-5 Carrier role
- 3-6 Command Acoustic Sound-Ranging Programme (ASP) role

**GENERAL INFORMATION**

- 2 This chapter has been sub-divided as listed at Para 1, and provides the user with the information required, including maintenance tasks, to operate the vehicle in various roles.

" ~~UNRESTRICTED~~

" ~~UNRESTRICTED~~

CHAPTER 3-1  
PORTABLE SHELTER  
CONTENTS

Para

- 1 General
- 3 Tubular frame
- 5 Shelter cover
- 11 Lights
- 14 Stowage

Fig

Page

1	Portable shelter – erected .....	1
2	Tubular frame .....	2
3	Shelter cover.....	3
4	Cover windows .....	3
5	Light .....	4
6	Stowage cases .....	5/6

**GENERAL**

**NOTE**

(1) Unless stated, the equipment is common to all marks of FV432, so where illustrations depict the equipment fitted to a mark of vehicle that is not relevant, the background can be ignored.

(2) The FV436 and FV439 have their own variants of Portable shelter (AESP 2350-T-250-741 refers)

1 The portable shelter kit consists of equipment to form a penthouse for Command purposes only, (Fig 1) and provides stowage facilities to carry the shelter equipment on the vehicle.

2 The fitting of this equipment does not change the overall width of vehicles. For instructions on how to install the portable shelter refer to AESP 2350-T-251-412 Inst Instr No. 4.

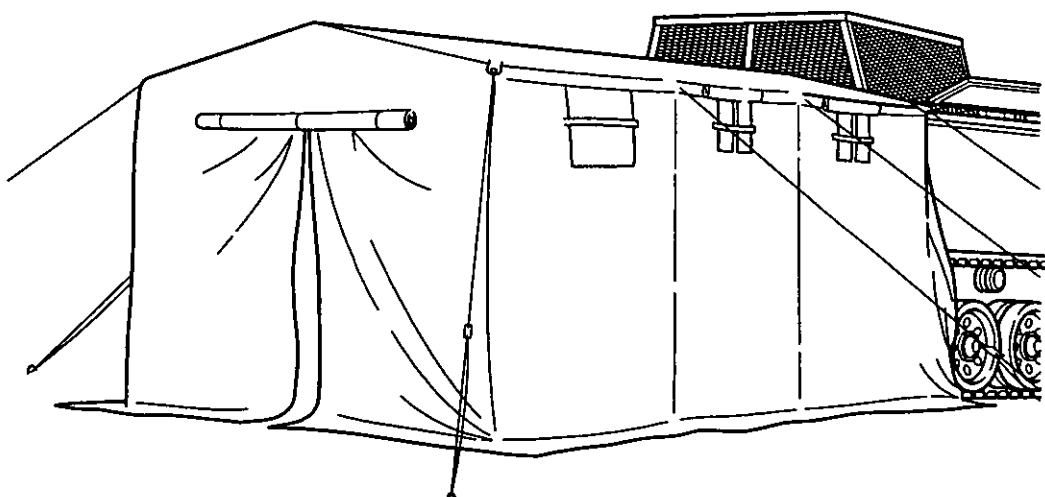

432/108a

Fig 1 Portable shelter - erected

### Tubular frame

3 The shelter cover is supported by a tubular framework consisting of four roof members (Fig 2(1)) each mounted on two side members (6) and connected to the next assembly by three tie members (2).

4 Each side member has a spike and a flange welded to the lower end to ensure a firm standing. The ends of the roof members locate in the top of the side members. The assembled side and roof members are linked together by the tie members whose circular disc ends drop into sockets welded to the upper end of the side members and to the centre of the roof members.

### Shelter cover

5 The cover consists of two sections. The forward end section (Fig 2(4)) is secured to the rear plate of the vehicle and attached by means of hooks and eyes to the cover rear section (Fig 3(4)), which forms the roof and walls. The walls are fitted inside and out with skirting flaps and the outside ones are retained in position by tent pins.

6 The cover is secured to the tubular frame by buckled straps (Fig 4(2)) sewn on the inside of the cover and the whole structure anchored to the ground by guy ropes (Fig 3(9)) and tent pins. The forward edges of the roof and sidewalls are strapped to staples welded on the vehicle roof and side plates.

7 Window flaps (Fig 4(5)) are fitted on the inside and outside (7) of the cover; they can be secured in either the closed or open position by means of hooks (6).

8 The forward end section is fitted with a door flap (Fig 2(3)), which can be lowered to cover the vehicle rear door. The flap can be secured in position by straps to cover the vehicle door or rolled up clear of it.

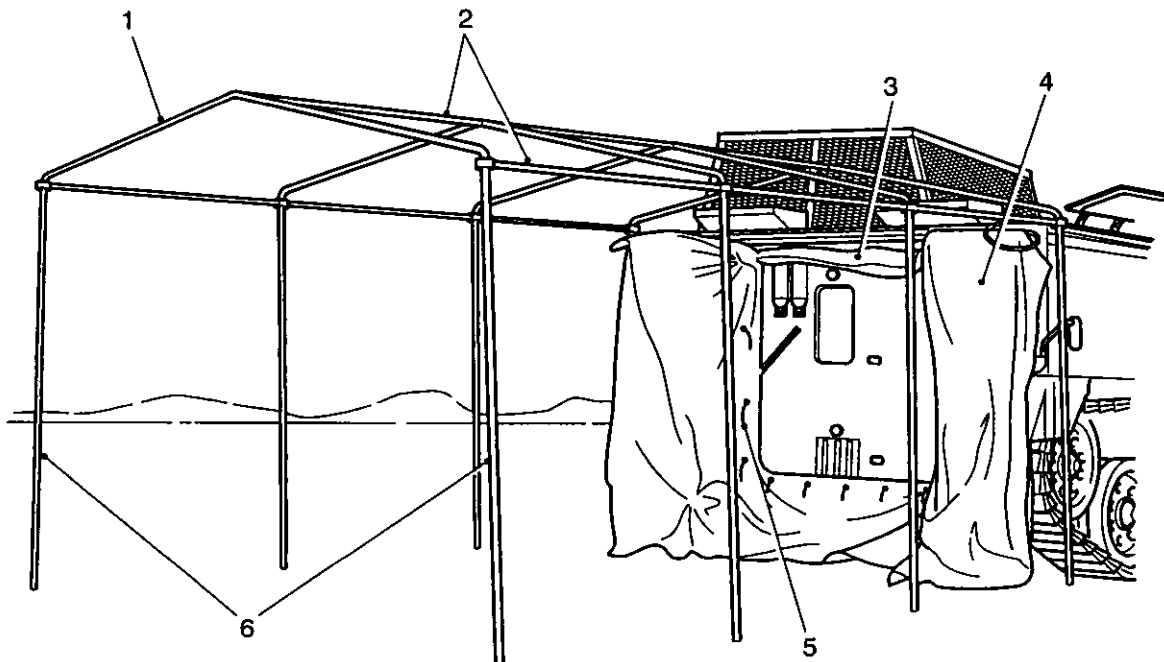

432/109a

1 Roof member  
2 Tie member  
3 Door flap

4 Forward end cover section  
5 Door flap securing straps  
6 Side members

Fig 2 Tubular frame

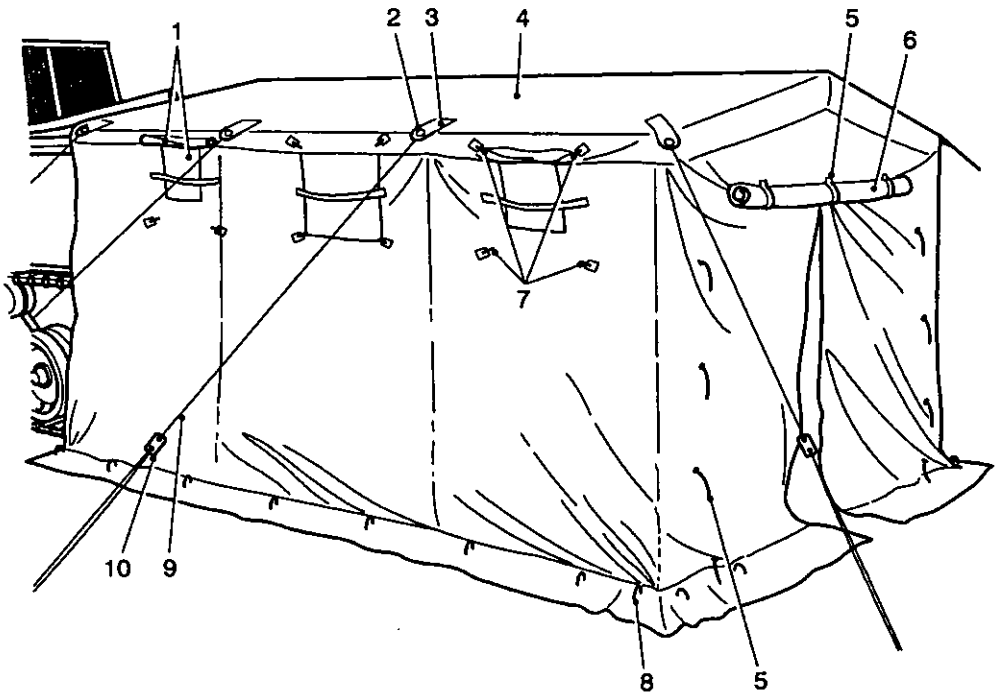

432/110

- |   |                              |    |                  |
|---|------------------------------|----|------------------|
| 1 | Window flaps                 | 6  | Door flap        |
| 2 | Wooden button with rope knot | 7  | Hooks            |
| 3 | Tab                          | 8  | Tent pins        |
| 4 | Cover, rear section          | 9  | Guy ropes        |
| 5 | Door flap straps             | 10 | Tension adjuster |

Fig 3 Shelter cover

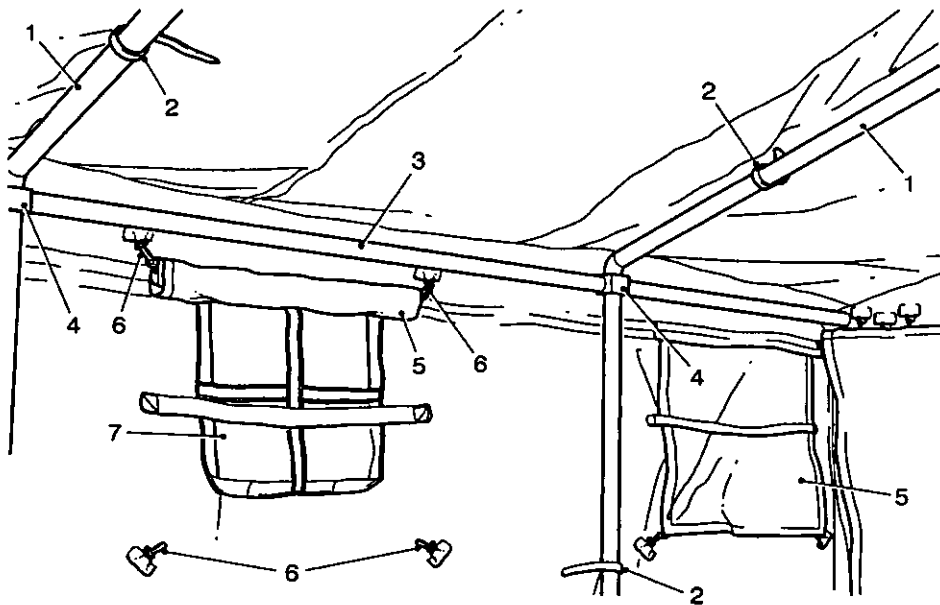

432/111

- |   |                     |   |             |
|---|---------------------|---|-------------|
| 1 | Roof members        | 5 | Inner flaps |
| 2 | Straps              | 6 | Hooks       |
| 3 | Tie member          | 7 | Outer flap  |
| 4 | Side member sockets |   |             |

Fig 4 Cover windows

9 The rear wall of the cover is parted centrally to provide an entry. An inner and outer door flap (Fig 3(6)) are fitted which can be separately installed to cover the entry or rolled up to give free access.

10 Each guy rope (9) is threaded through a tab (3) and secured by means of a wooden button (2) and a simple knot. Guy rope tension is effected by moving the tension adjuster (10) to which the other end of the rope is attached.

### Lights

11 Interior lighting for the shelter is provided by four fluorescent lights (Fig 5), which clamp to the roof members in position to suit the operators/commanders preference.

12 The lights are interconnected in series by three harnesses and connected to either independent batteries or the external lighting socket on the vehicle rear plate. Alternative harnesses are provided in the kit to suit either power source.

13 Each light is fitted with a toggle switch (5) and two plug connections, one plug (7) at each end. The clamp arms (1) are tightened by means of knurled screws (2).

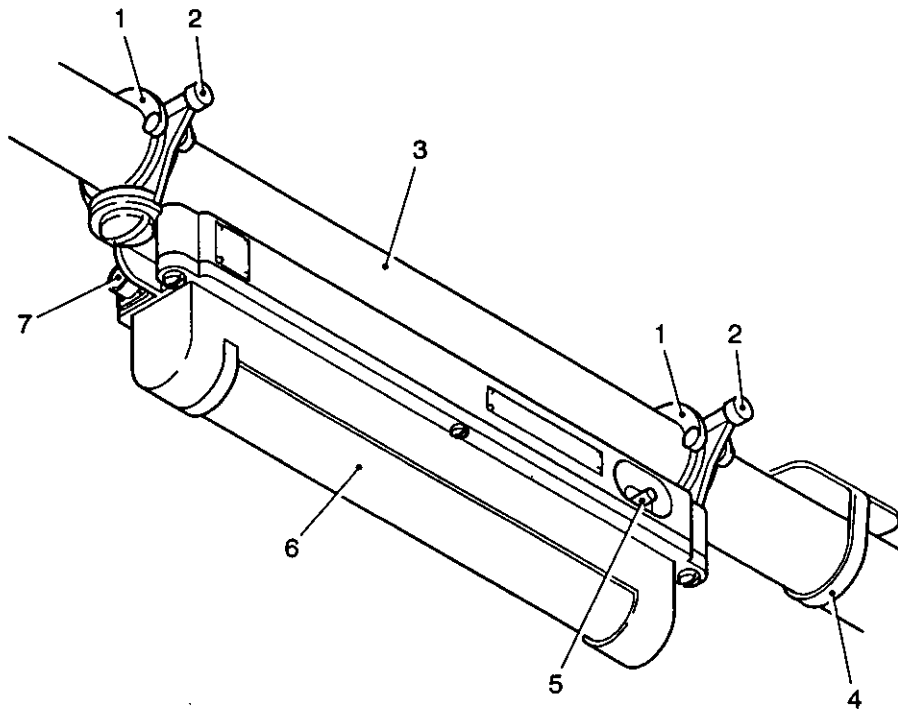

432/112

1	Clamp arm	5	Switch
2	Knurled screws	6	Fluorescent tube
3	Roof member	7	Connection plug
4	Strap		

Fig 5 Light

### Stowage

14 Brackets are included in the kit to be attached by screw to tapped bosses welded to the vehicle side plates and accommodate the tubular frame items when the shelter is not in use.

15 Two wooden stowage cases (Fig 6) are supplied with the kit for stowing the cover and lighting equipment. When the kit is used in conjunction with a command role kit, insufficient space is available for the case and the lights and harnesses should be stowed on a pannier plate behind the map-boards and the folded cover with the ropes and pins inside it, deposited on the floor behind the bench seat.

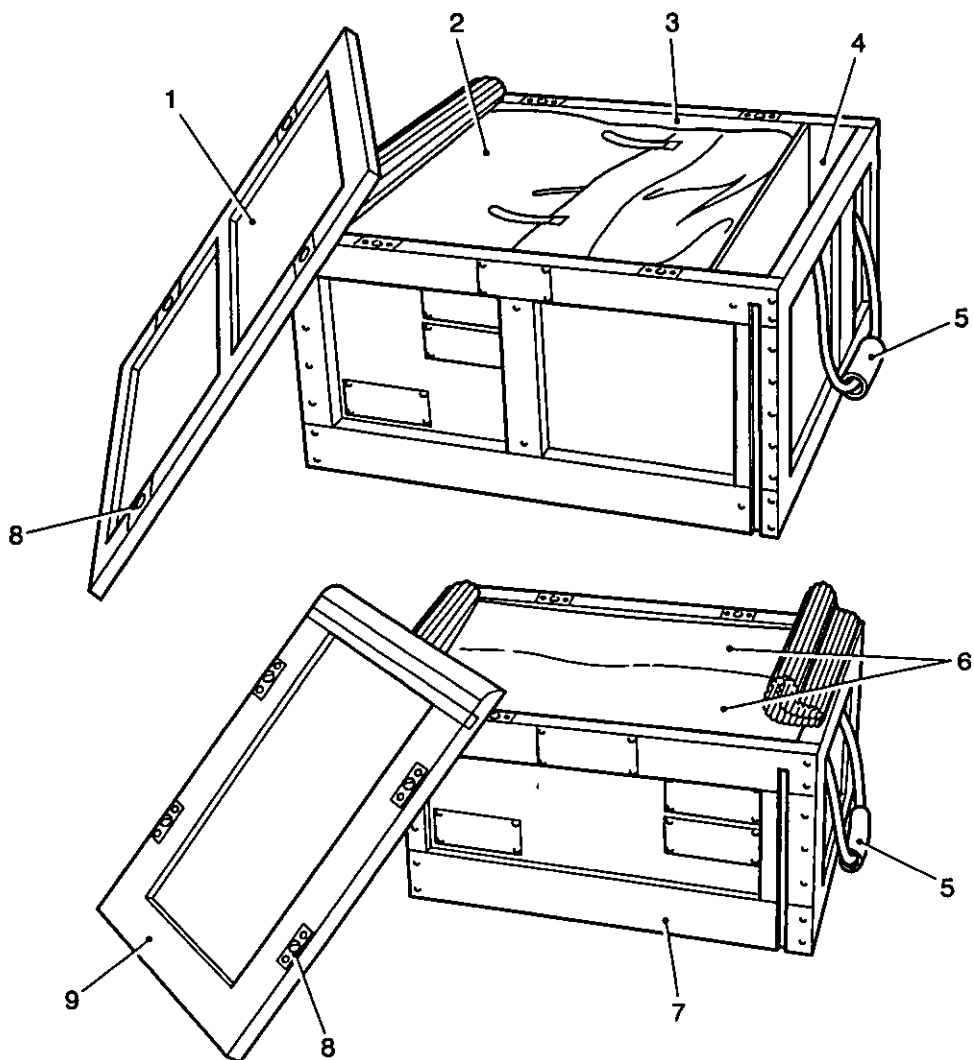

432/113

- 1 Lid
- 2 Cover
- 3 Case
- 4 Tent pin compartment
- 5 Lifting handles

- 6 Lights (in cartons)
- 7 Case
- 8 Lid securing screws
- 9 Lid

Fig 6 Stowage cases



UNRESTRICTED

UNRESTRICTED

CHAPTER 3-2  
COMMAND ROLE  
CONTENTS

Para

- 1 General
- 2 Communication equipment
- 3 Description
- 7 Driver's compartment
- 8 Commander's compartment
- 10 Command post compartment
- 13 Sliding table assemblies
- 14 Extending the sliding table
- 15 Retracting the sliding table
- 16 Personnel seats
- 17 Maintenance
- 18 Light fittings
- 19 Document boxes

Fig

Page

- 1 Layout of Command post compartment ..... 3
- 2 Sliding table ..... 5/6

**GENERAL**

**NOTE**

Unless stated, the equipment is common to all marks of vehicle, so where illustrations depict the equipment fitted to a mark of vehicle that is not relevant, the background can be ignored.

1 The Command role consists of equipment required to convert the personnel compartment into an office (see Fig 1) containing tables, a bench seat on the left hand side of the crew compartment, and extra lighting. Additional radio installation and cables are supplied in separate kits.

**COMMUNICATIONS EQUIPMENT**

2 Fig 1 is a schematic diagram detailing the communication equipment installed in the Command post compartment, it also details the equipment fitted in the commander's and driver's stations, and is included for reference only. Full details of the operation of the equipment is detailed in relevant Bowman Radio Communication Interactive Electronic Technical Publication (IETP).

**Description**

**REDACTED**

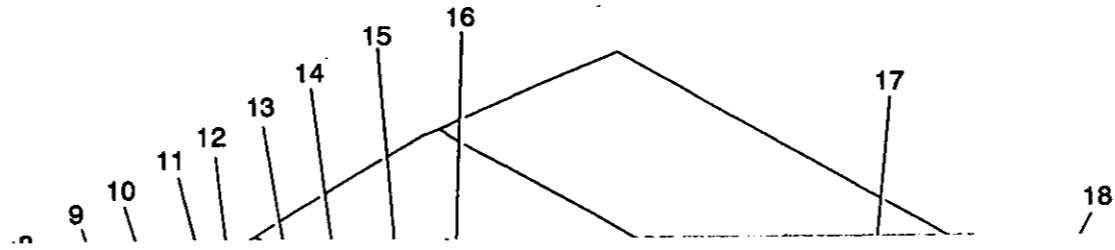

REDACTED

Fig 1 Layout of communication equipment

### Driver's compartment

7 A Bowman Audio Interface Unit (BAIU) (19) is installed to the right of the driver's position, above the battery box.

### Commander's compartment

8 A Crewman Personal Unit (CPU) is installed on a flying lead in the commander position.

9 A two-tier radio rack is installed to the right of the vehicle commanders' position. VHF Mounted role radio High Power (VMOP) Radios are fitted in a Dual Radio mount (DRM) in the lower tier of this rack with a VHF PA (23) (Integrated Filter power Amplifier (IFPA) or Radio Frequency Power Amplifier (RFPA) depending on the configuration). A Vehicle User Data Terminal (VUDT) (18) and one User Control Device UCD (22) are mounted on the top tier of the rack within reach of the vehicle commander. The Precision Lightweight GPS Receiver (PLGR) (20) is mounted in between the VUDT and UCD.

### Command compartment

10 Two two-tier radio racks are installed in the LHS sponson area, behind the original seating position on the left hand side of the vehicle. The rear rack houses the BNAU (4) on the bottom shelf, and the HCDR (6) on the top shelf. The forward rack houses the Legacy SCRA TX/RX (9) on the bottom shelf, and the BOWMAN HF equipment is located on the top shelf.

11 On the RHS of the vehicle three crew seats (27) are installed (as fitted to the basic 432 variant) to give seating positions facilitating operational access for four crew to the shelf/table-mounted equipment. Opposite the seating two sliding desks (31) (one long and one short) are mounted to support the Staff User Data Terminals (SU DT) (2 and 7) and UDTs. The desks are recessed in order that the UDT IKEE does not inhibit good user access. An 850mm x 850mm map board is mounted behind the long desk on top mounted hinges. The hinges allow the map board to be suspended forward towards the Staff working on the desks for easier access. Two UCDs (5 and 16) are mounted statically, one mounted to the left of the short desktop, the other mounted on the cross bulkhead wall.

12 A radio table/shelf (12) is installed on the cross bulk head wall opposite the rear access door of the vehicle. This table houses the Legacy SCRA CIG (13), Pre Post Selector (25), second HF radio set (HF-3 radio /HFPA (25W)/ Pre Post Selector), an HQ printer (24). The printer is mounted transversely across the vehicle; this allows the commander to access the paper tray.

### SLIDING TABLE ASSEMBLIES

13 The Command staff compartment is equipped with two sliding table assemblies (Fig 1 (31)) one for the Staff Officer and one for an operator, each of which provides a platform for retaining the Staff User Data Terminals (SU DT). Each sliding table can be secured in the extended or retracted position.

#### Extending the sliding table assemblies

14 The larger (rearmost) sliding table has two spring loaded locking handles, the smaller (forward) table only has one spring loaded locking handle. The procedure to extend both sliding tables is similar and is as follows:

14.1 Pull down and rotate the spring loaded locking handle(s)(Fig 2(4) 90 degrees.

14.2 Pull the table (2) forward and lock in the extended position by inserting the locking pins (1) through the table and into the bracket (3).

#### Retracting the sliding table assemblies

15 The procedure to retract the sliding table assemblies is the reverse of the procedure detailed for extending.

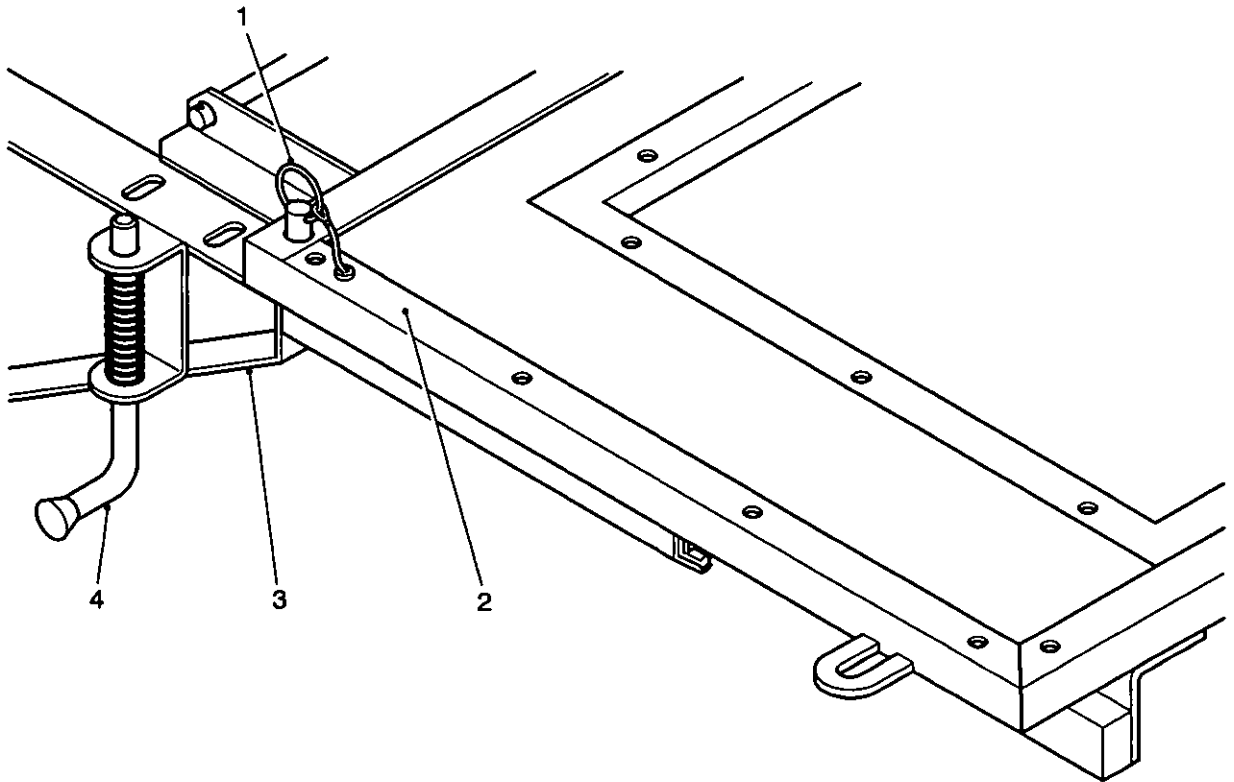

430/20152

- |   |                        |   |                              |
|---|------------------------|---|------------------------------|
| 1 | Locking pin (2 off)    | 3 | Bracket                      |
| 2 | Sliding table assembly | 4 | Spring loaded locking handle |

Fig 2 Sliding table

## PERSONNEL SEATS

16 Three double seats (Fig (1 (27))) are fitted along the RH side of the Command compartment. In the raised position, the seats are held by a double link, which moves over centre against the side plate. Each seating place is provided with a lap belt.

### Maintenance

17 User maintenance for the personnel seats is restricted to checking the security of the seat mounting fixtures, ensuring the locking catch mechanisms operate to retain the seats in the vertical and horizontal positions, and all hinges and locking catches are lightly oiled.

## LIGHT FITTINGS

18 LED light stripes are mounted along the centre of the crew compartment roof so that the User Control Devices (UCD) can be illuminated. The supply is controlled by switch No. 2 on the auxiliary junction box.

## DOCUMENT BOXES

19 Five document boxes are bolted to the inside of the vehicle, one on the rear door, one on either side of the door on the rear plate and one on each outer segment of the mortar hatch. Each box has a hinged lid which when closed is retained by a spring clip at each side. Handles are provided for opening the lids.

~~UNRESTRICTED~~

~~UNRESTRICTED~~

**CHAPTER 3-3**  
**AMBULANCE ROLE**  
**CONTENTS**

Para

- 1 General
- 5 Four stretcher application
- 6 Upper stretcher
- 7 Carrier brackets
- 9 Carrier frame
- 13 Mounting
- 14 Stowage
- 16 Lower stretcher
- 17 Pedestal brackets
- 18 Mounting
- 19 Two stretcher application with seats
- 21 Ventilation fan
- 22 Servicing

Fig

Page

1	Four stretcher application .....	2
2	Carrier bracket .....	3
3	Carrier frame.....	4
4	Carrier frame, stowed .....	5
5	Pedestal bracket.....	6
6	Two stretcher application.....	7

**GENERAL**

- 1 The ambulance variant comprises of vehicles fitted with either 4 or 2 carrying stretchers with associated brackets and equipment to secure the stretchers in position.
- 2 For the two stretcher application the personnel seats are retained on the right side and the two stretchers are installed on the left side.
- 3 Unless stated, the equipment is common to all marks of vehicle, so where illustrations depict the equipment fitted to a mark of vehicle not relevant, the vehicle background should be ignored.
- 4 For instructions on how to convert the vehicles to the ambulance role refer to AESP 2350-T-251-412 Inst Instr No. 6.



**FOUR STRETCHER APPLICATION**

5 Figure 1 illustrates the layout of the four stretcher application. The four stretchers are mounted in the crew compartment two in the upper position (Fig 1 (1)) and two in the lower position (4).

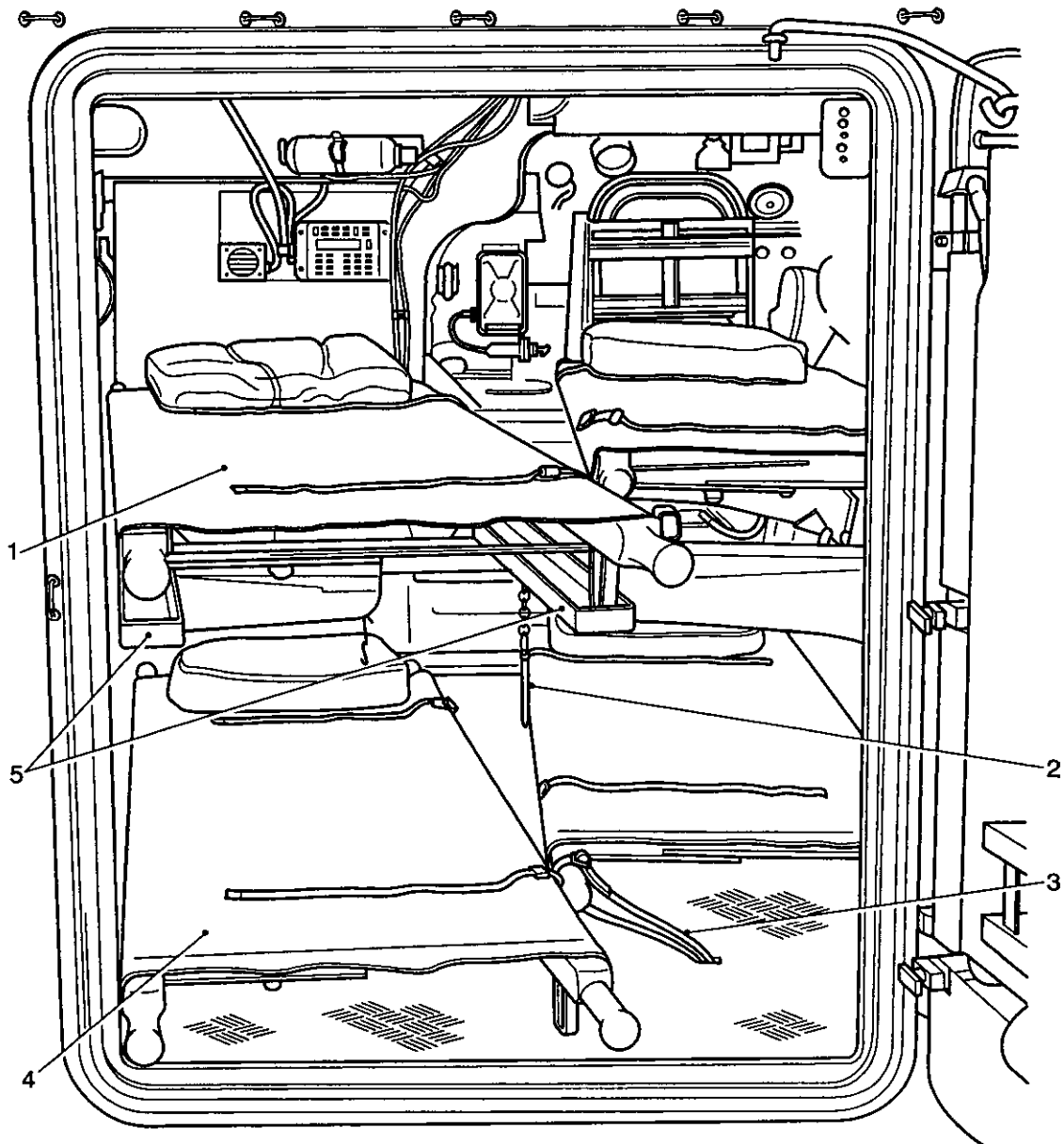

430/20146

1 Upper stretcher  
2 Locking pin  
3 Anchoring strap

4 Lower stretcher  
5 Carrier frame

Fig 1 Four stretcher application

**Upper stretcher**

6 The upper stretchers (1) are mounted on carrier frames and secured in position using locking pins (2). Each carrier frame is in turn secured to two carrier brackets using locking pins. The carrier frames and brackets can be raised about hinges and stowed (Fig 4) using the straps (1), (2) secured to the roof and the fuel tanks.

Carrier brackets

7 The carrier brackets (Fig 2(5)) are hinged to the vehicle lower side plates by hinge pin brackets (3) bolted to the side plates. The carrier brackets are handed by the positioning of the hole for the carrier frame pivot (2), the hole being toward the rear of the vehicle in each bracket. Stop plates (4) welded to the carrier bracket side plates are brought into contact with the hinge brackets (3) when the carrier frame is lowered.

8 Mounted on each rear carrier frame bracket is a guide channel (1) with a sliding insert (7); the guide channel is secured and pivoted at the hinged end of the carrier frame bracket.

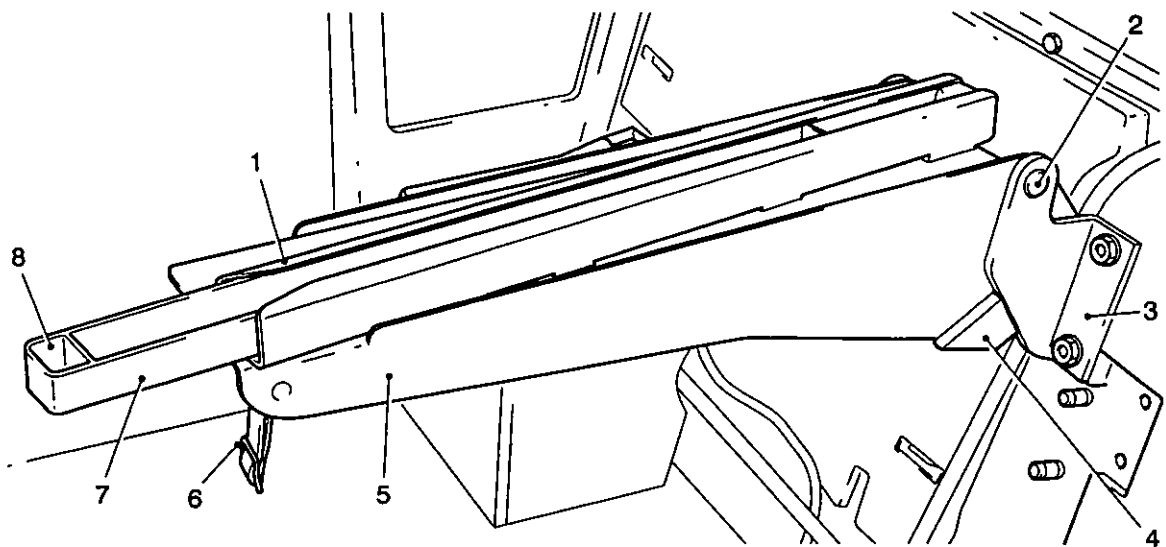

432/126

- |   |                       |   |                     |
|---|-----------------------|---|---------------------|
| 1 | Guide channel         | 5 | Carrier bracket     |
| 2 | Carrier bracket pivot | 6 | Strap               |
| 3 | Hinge bracket         | 7 | Sliding insert      |
| 4 | Stop plate            | 8 | Locating pin pocket |

Fig 2 Carrier bracket

Carrier frame

9 The two carrier frames (Fig 3(7)) are rectangular, the longitudinal members having a lipped channel section and the cross members a shallow inverted channel section.

10 The longitudinal members act as guides to the carrier sliding inserts (1) into which the stretcher feet rest. The carrier inserts are retained in the guides by stops (5) welded to the lips of the guides. Mounted on the under-side of the longitudinal members are rollers, which project through the channel and support the carrier inserts.

11 The carrier frames are handed by the positioning of the locating and pivot pins and the stretcher locking pins (4). The locating and pivot pin of each carrier is located at the forward end adjacent to the vehicle plate. The location pin secures the sliding insert in the carrier frame.

12 The stretcher locking pins are attached to the carrier frames by retaining chains (6) each pin has two locations. In the outer position (3), it passes through a foot of the stretcher. In the inner position, it retains the carrier insert. The pins are attached to the outer longitudinal members.

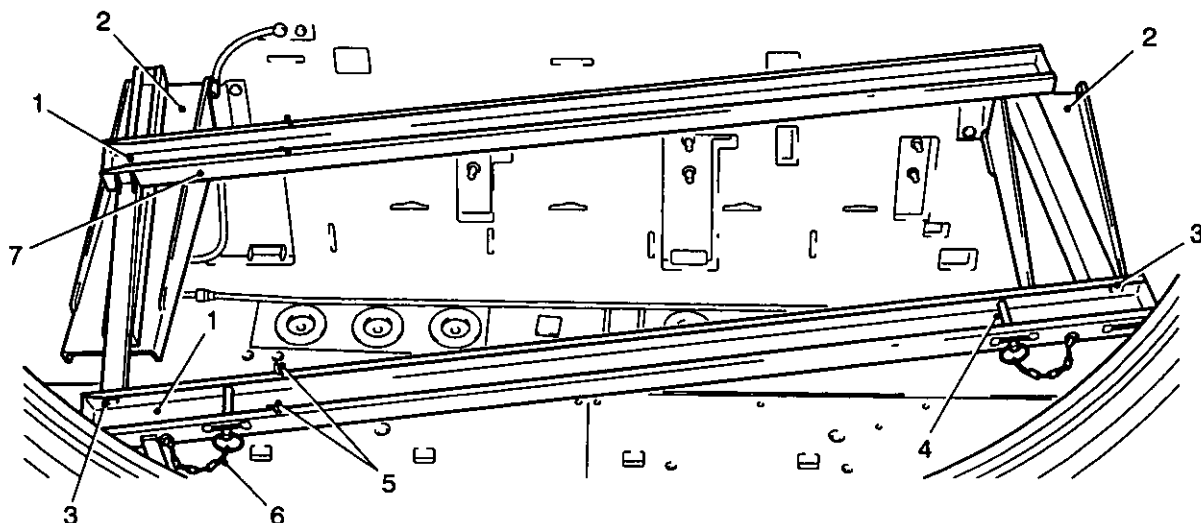

432/127

1	Sliding insert	5	Stops
2	Carrier bracket	6	Retaining chain
3	Locking pin outer location	7	Carrier frame
4	Locking pin		

Fig 3 Carrier frame

Mounting

13 To mount an upper stretcher to the carrier frame proceed as follows:

13.1 If in the stowed position lower the carrier brackets and frame assembly by releasing the straps (Fig 4 (1 & 2)).

13.2 Release the locking pins securing the carrier frame (Fig 3 (7)) to the hull side and slide the carrier frame outwards (Fig 1).

13.3 Release the locking pins securing the carrier frame sliding inserts (1) and pull outwards.

13.4 Locate the stretcher into the sliding inserts and push the stretcher and inserts fully back in to the carrier frame.

13.5 Secure the stretcher to the carrier frame by passing the locking pins through a foot of the stretcher and into the outer location (3).

13.6 Slide the complete carrier frame assembly back to the hull wall and secure using the locking pins.

14 Removal of an upper stretcher is the reverse of mounting.

Stowage

15 The carrier frames and brackets can be raised about the hinges and stowed using the straps (Fig 4 (1 and 2)) secured to the roof and the fuel tanks.

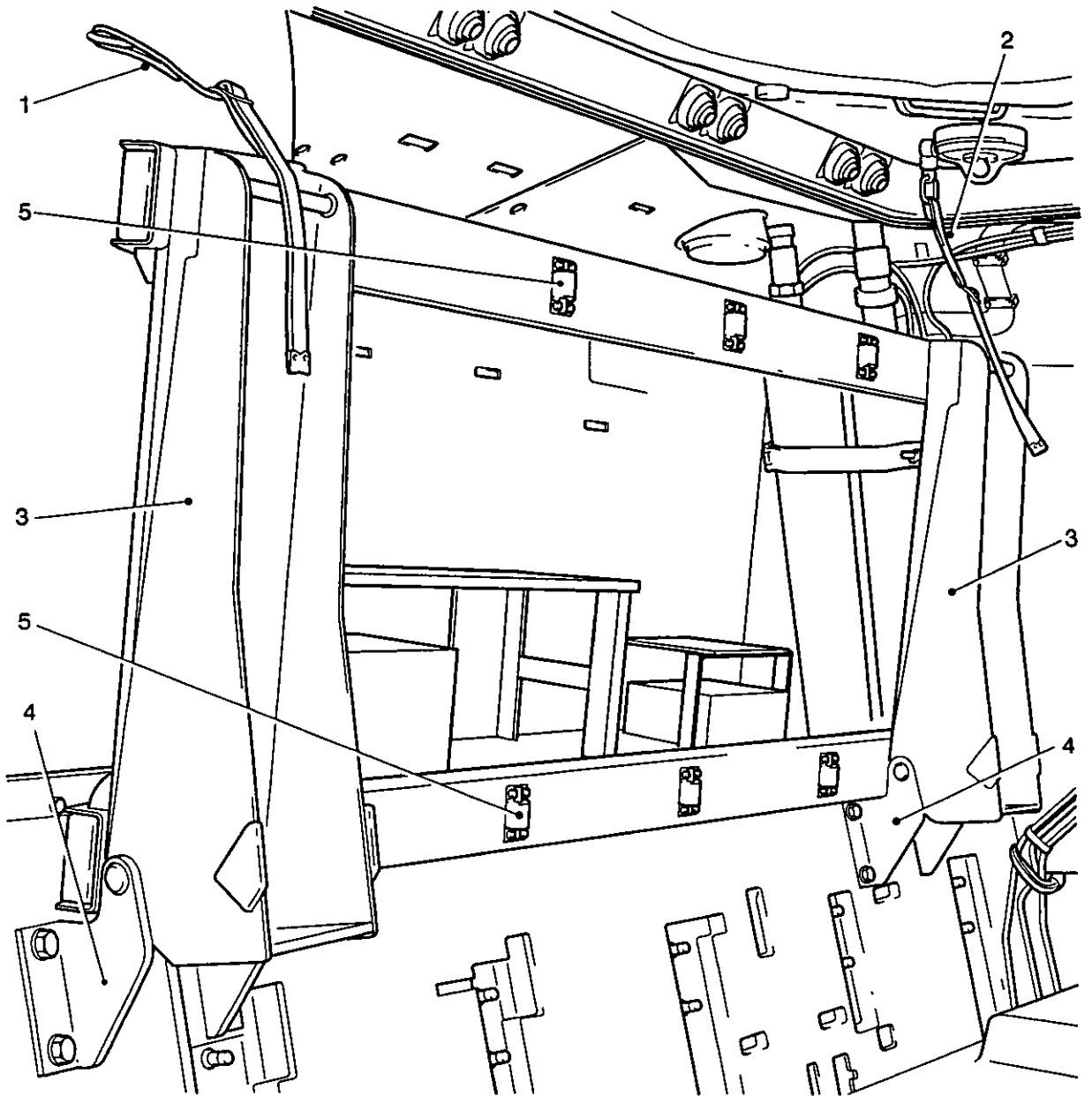

430/20148

- 1 Stowage strap from fuel tank
- 2 Stowage strap from roof
- 3 Carrier bracket

- 4 Hinge bracket
- 5 Rollers

Fig 4 Carrier frame, stowed

**Lower stretcher**

16 The lower stretchers (Fig 1 (4)) are secured to the crew compartment floor. A pedestal bracket (Fig 5) retains the forward end in position, while the rear end is secured by a strap threaded through the floor plate attachment (3) and passed round the stretcher handle.

**Pedestal bracket**

17 The pedestal brackets (Fig 5(2)) are bolted to the floor at the forward end of the personnel compartment.

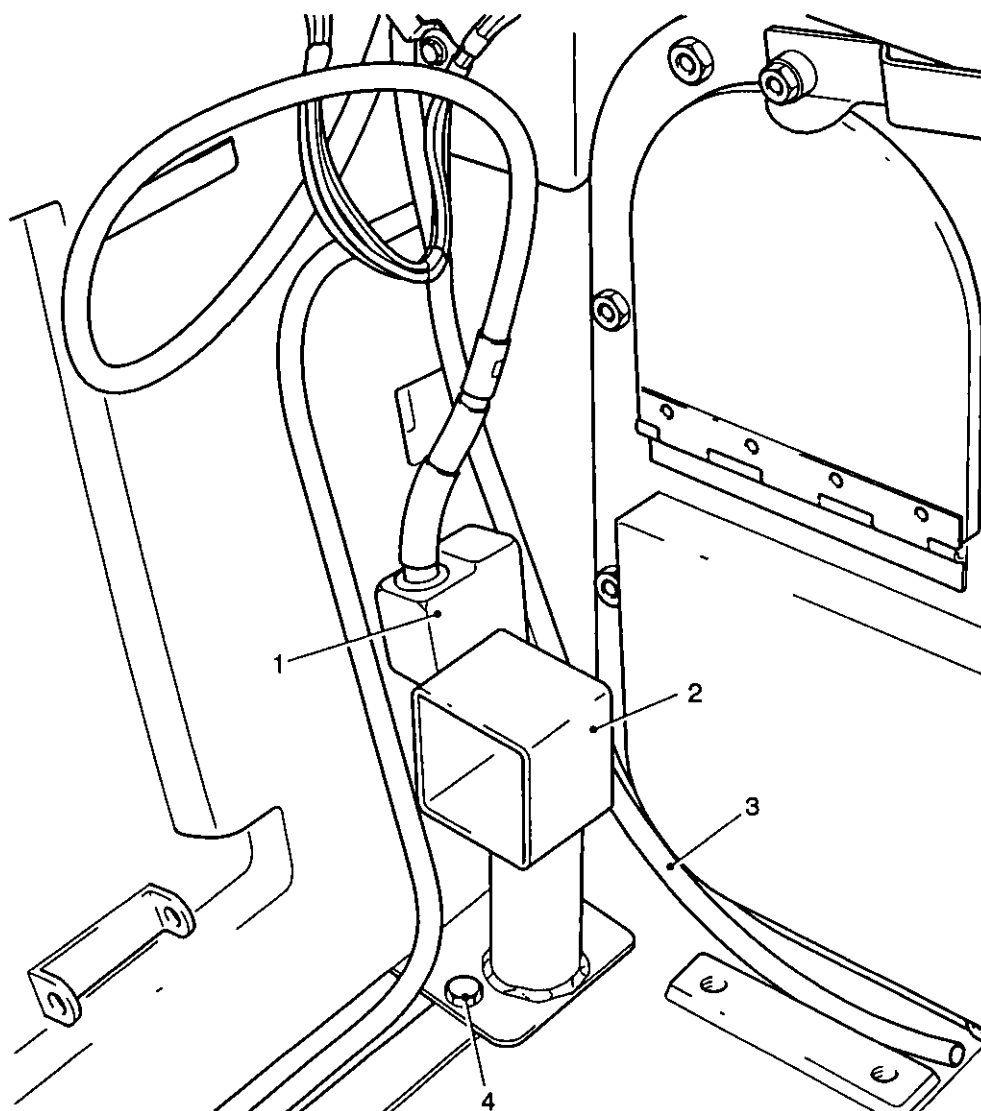

432/129

1 Positive cable connector  
2 Pedestal bracket

3 Vent tube  
4 Securing bolts

Fig 5 Pedestal bracket

**Mounting**

18 To secure a lower stretcher in the vehicle locate the forward inner stretcher handle in the pedestal bracket and secure the strap (Fig 1 (3)) over the outer rear handle of the stretcher. Ensure the stretcher is fully secured before moving off.

### TWO STRETCHER APPLICATION WITH SEATS

19 Figure 6 illustrates the layout of the two stretcher application. Two stretchers are mounted on the left hand side of the crew compartment, one in the upper position (6) and one in the lower position (4). The right hand crew seats are retained leaving a clear passage between the rear door and the commander's and driver's compartments.

20 Mounting of the upper and lower stretchers is the same procedure as for the four stretcher application.

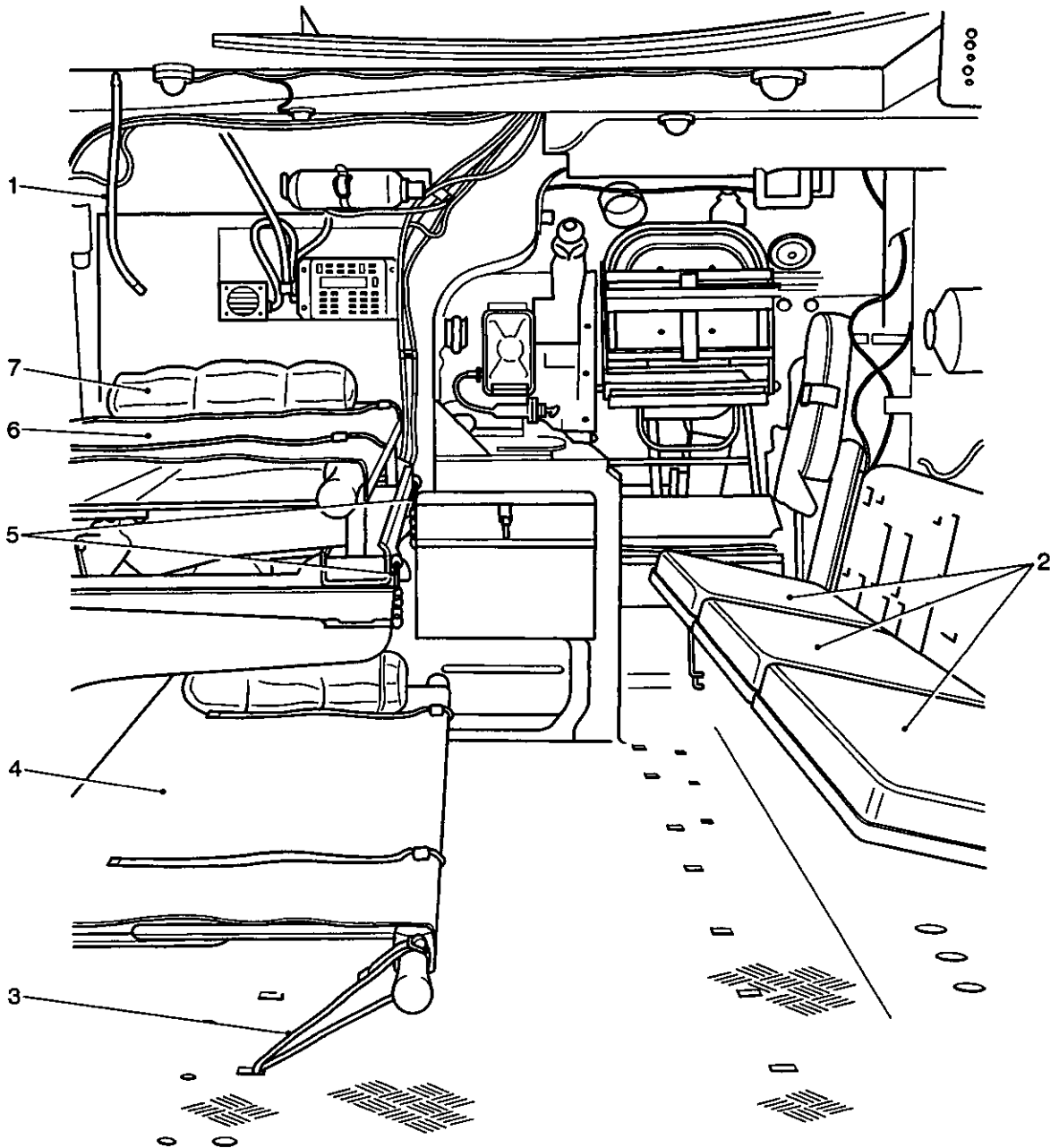

430/20147

- 1 Storage cleat
- 2 Personnel seats
- 3 Anchoring strap
- 4 Lower stretcher

- 5 Locking pins
- 6 Upper stretcher
- 7 Pillow

Fig 6 Two stretcher application

**VENTILATION FAN**

21 Installation of the ambulance variant kit requires the removal of the ventilation batteries, but included in the kit are harnesses which, when installed, enable the ventilation fan to be connected to the radio battery circuit.

**NOTE**

Running the fan (and heater, if fitted) with the engine stopped greatly reduces the time for which the radio station can be used on silent watch. When the engine is running, the radio distribution box battery switch must be turned to 'ON' to connect the radio batteries to the charging circuit.

**SERVICING**

22 Using an oilcan, lightly oil the pivot pins, the carrier frame rollers, (Fig 4(5)) and the carrier bracket hinges. Apply a thin smear of powdered graphite to the sliding contact faces of the channel inserts.

**CHAPTER 3-4**  
**MORTAR ROLE**  
**CONTENTS**

Para

- 1 81mm mortar (L16A1) adaptor mounting
- 4 Brief description
- 10 Vehicle level indicator
- 11 Trilux lamps (WARNING)
- 12 Base plate assembly
- 13 Platform assembly
- 14 Bearing plate and scale (WARNING)
- 15 Removal
- 16 Refitting
- 17 Monopod assembly
- 18 Barrel clamp and buffer assembly
- 19 Elevating gear
- 20 Traversing gear
- 21 Cross levelling gear
- 22 Barrel stowage bracket
- 23 Barrel fitting
- 24 Barrel removal
- Sight unit quadrant No 15
- 25 Brief description (WARNING)
- 26 Fitting
- 27 Removal
- 28 Stowage
- 29 Sight Maintenance
- 30 Mortar Transit position
- 31 Mortar firing position
- 32 Maintenance (CAUTION)
- 40 Bomb racks
- 45 Stowage grills
- 46 Transverse rail
- 47 Double seat
- 48 Single seat
- 49 Weapon stowage

Fig

Page

1	Mortar mount, front left .....	3
2	Mortar mount, rear right .....	4
3	Base plate assembly .....	5
4	Platform assembly .....	6
5	Bearing plate and scale .....	7
6	Monopod assembly .....	8
7	Barrel clamp and buffer assemblies .....	9
8	Monopod controls .....	10
9	Mortar barrel stowage bracket .....	11
10	Barrel clamp safety catch .....	11
11	Sight Unit Quadrant No 15 .....	12
12	Location of mortar mount lubricators .....	15
13	Pannier bomb rack .....	16
14	Locking bar (pannier rack) .....	17
15	Rear door bomb stowage .....	17
16	Stowage grills .....	19
17	Transverse rail .....	20



**81 mm MORTAR (L16A1) ADAPTOR MOUNTING**

- 1 The procedure detailing the installation of the 81 mm Mortar (L16A1) adaptor mounting is described in AESP 2350-T-251-412 Inst Instr No. 2.
- 2 In the mortar role, the FV432 rear door cannot be used for entry or exit due to the installation of ammunition racking. Entry or exit is therefore made through the commander's hatch. To ensure security of the vehicle when unattended an external locking device is fitted to the hatch door.
- 3 The servicing schedule for the mortar and mounting is included in this sub-chapter. For details of the mortar and its operation, refer to AESP 1015-C-100 series.

**Brief Description**

REDACTED

REDACTED

Fig 1 Mortar mount, front left

# REDACTED

Fig 2 Mortar mount, rear right

- |   |                           |   |                            |
|---|---------------------------|---|----------------------------|
| 1 | Turntable traverse handle | 6 | Breech plug socket         |
| 2 | Throw over link           | 7 | Well                       |
| 3 | Cross level hand wheel    | 8 | Foot rail                  |
| 4 | Elevating handle          | 9 | Resilient mount dust cover |
| 5 | Strut rest locking pin    |   |                            |

### Vehicle level indicator

10 The vehicle level indicator is similar to the one mounted on the tower top plate but is mounted on the transverse bulkhead to the rear of the commander's position and is illuminated by TRILUX lamps.

### Trilux lamps

### WARNING

**RADIOACTIVE GAS. THE VEHICLE LEVEL INDICATORS CONTAIN TRILUX LAMPS. WHEN A LAMP IS BROKEN A SMALL QUANTITY OF RADIOACTIVE TRITIUM GAS IS RELEASED. IF A LAMP IS BROKEN, VACATE THE VEHICLE IMMEDIATELY. IN CONFINED SPACES, DOORS AND WINDOWS SHOULD BE OPENED. ALLOW 30 MINUTES FOR THE TRITIUM GAS TO DISPERSE. DO NOT HANDLE BROKEN LAMP PARTS. ENSURE NO ONE BREATHES IN CONTAMINATED AIR.**

11 TRILUX lamps contain glass capsules containing radioactive tritium gas. There is no hazard if a lamp is broken in the open air, but should a lamp be broken inside the vehicle, the vehicle should be vacated immediately and the compartment ventilated for thirty minutes to ensure that no-one breathes in a concentration of the gas.

**BASE PLATE ASSEMBLY**

12 The base plate assembly (Fig 3(1)) is mounted on a resilient mat and is secured to a strengthened area of the vehicle floor by bolts through the 12 shock absorber mounts (4).

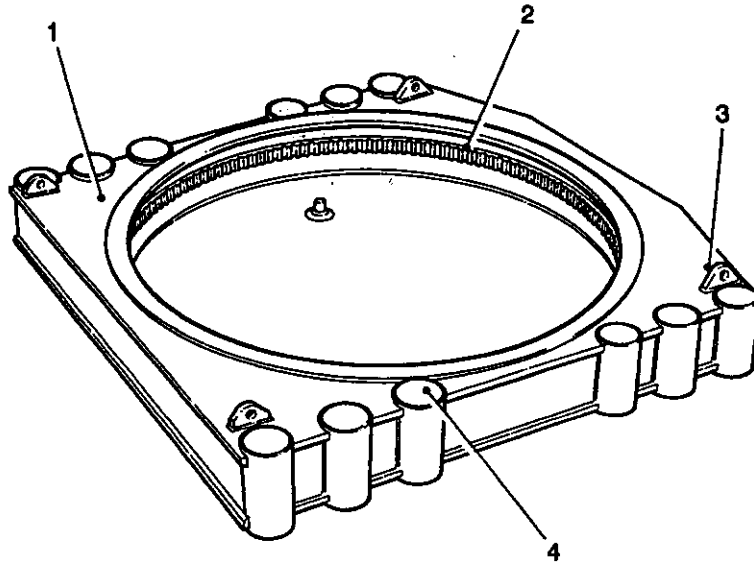

432/494

- 1 Base plate assembly
- 2 Traverse ring

- 3 Lifting eye
- 4 Shock absorber mounts

Fig 3 Base plate assembly

**PLATFORM ASSEMBLY**

**REDACTED**

**Bearing plate and scale**

**WARNING**

**RADIOACTIVE GAS. THE VEHICLE LEVEL INDICATORS CONTAIN TRILUX LAMPS. WHEN A LAMP IS BROKEN A SMALL QUANTITY OF RADIOACTIVE TRITIUM GAS IS RELEASED. IF A LAMP IS BROKEN, VACATE THE VEHICLE IMMEDIATELY. IN CONFINED SPACES, DOORS AND WINDOWS SHOULD BE OPENED. ALLOW 30 MINUTES FOR THE TRITIUM GAS TO DISPERSE. DO NOT HANDLE BROKEN LAMP PARTS. ENSURE NO ONE BREATHES IN CONTAMINATED AIR.**

Removal

- 15 The procedure for the removal of the bearing plate and scale is as follows:
  - 15.1 Move the vehicle heading lens (Fig 5(2)) clear of the scale (4).
  - 15.2 Unscrew the six socket headed screws (7) securing the bearing plate (6) and lift the plate and scale clear.
  - 15.3 Remove the scale ring

Refitting

- 16 The procedure for refitting the bearing plate and scale is the reverse procedure for removal, noting the following:
  - 16.1 The six socket headed screws are to be tightened progressively in a clockwise sequence.



**REDACTED**

Fig 5 Bearing plate and scale

~~RESTRICTED~~

MONOPOD ASSEMBLY

0111-0

REDACTED

497

et

Fig 6 Monopod assembly

~~RESTRICTED~~

Barrel clamp and buffer assemblies



REDACTED.

↳ → tripod assembly

Fig 7 Barrel clamp and buffer assemblies



Elevating gear

rel.  
the  
or

ing

**REDACTED**

4 Travelling handle

Fig 8 Monopod controls

Cross-levelling gear

**Barrel stowage bracket**

22 The barrel stowage bracket (Fig 9) is mounted on the monopod below the elevating mechanism as shown in Fig 6 and is used to stow the mortar barrel when not in use.

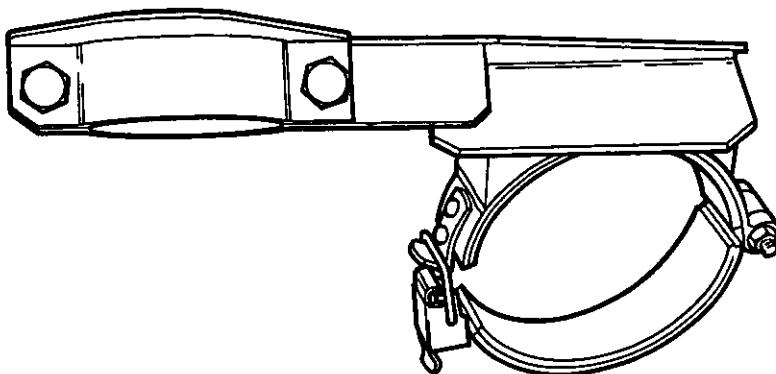

432/500

Fig 9 Mortar barrel stowage bracket

**Barrel fitting**

**Barrel removal**

**REDACTED**

Fig 10 Barrel clamp safety latch

**SIGHT UNIT QUADRANT No 15**

**Brief description**

**WARNING**

**TRILUX LAMPS. THE SCALES AND BUBBLES OF THE SIGHT CONTAIN TRILUX LAMPS. IF A LAMP IS BROKEN A SMALL QUANTITY OF RADIO ACTIVE TRITIUM GAS IS RELEASED. IF A LAMP IS BROKEN INSIDE THE VEHICLE, VACATE THE VEHICLE IMMEDIATELY; VENTILATE THE VEHICLE FOR 30 MINUTES. ENSURE THAT NO ONE BREATHE IN CONTAMINATED AIR.**

**REDACTED**

Fig 11 Sight unit quadrant No 15

Fitting

:

### Removal

- 27 The procedure for removing the sight is as follows:
- 27.1 Move the locking arm forward to the unlocked position.
  - 27.2 Pull down on the finger grip and rotate the locking plate to the unlocked position.
  - 27.3 Rotate the release cam (11) and remove sight.

### Stowage

28 To stow the sight in its case set the elevation scales to 1100 mils, set the locking plate in the unlocked position, put in case with the dovetail uppermost.

### **Sight Maintenance**

29 Refer to the sight manufacturers handbook.

### **MORTAR TRANSIT POSITION**

- 30 The procedure to place the mortar in its transit position is as follows:
- 30.1 Traverse the mount so that the barrel is pointing diagonally across the vehicle.
  - 30.2 Remove the sight.
  - 30.3 Secure the barrel in the barrel stowage bracket.(Fig 6(6))
  - 30.4 Retract the monopod and engage the buffer in the buffer clamp (Fig 7(5)).
  - 30.5 Close and secure the mortar hatch doors.

### **NOTE**

For travelling purposes with the mortar mounted the breech plug end of the mortar can be lowered into the well (Fig 2(7)) of the turntable to reduce the height and allow the mortar hatch covers to be closed. The well is lined with a removable plastic bucket. To stow the strut when the mortar has been dismantled, move the throw over link to the inner position, disengage the strut rest locking pins (5) and release the strap (Fig 1(2)), raise the strut rest (1) then lower the telescoped strut onto the rest and secure with the strap.

### **MORTAR FIRING POSITION**

31 The procedure to place the mortar in its firing position is a reverse of the procedure detailed in Para 30.

### **MAINTENANCE**

- 32 Servicing includes a visual inspection of the equipment to ensure it is in good condition, correctly assembled and secured.
- 33 All lubricating points, whether nipples or surfaces and the surrounding areas must be cleaned before applying lubricant. All excess lubricant should be wiped off after working the joints to ensure that inaccessible parts are adequately greased in accordance with AESP 2350-T-250-601.
- 34 Clean the exposed surfaces of the scaler lenses and the level indicator by washing with clean water, then drying with clean cotton rag. On no account should mud or dirt be removed in a dry condition, nor should the surfaces be touched directly with the fingers.

- 35 Lift out the plastic bucket from the well and empty any water present, clean and dry all surfaces then replace, ensuring that the sealing presses against the sides of the well to form a watertight seal.
- 36 Remove the resilient mount dust cover (Fig 2(9)) and check the security of the bolts and tighten them in accordance with AESP 2350-T-250-601. Check that the cover vent holes are clear before replacing the covers.
- 37 When lubricating the turntable, the access plate (Fig 1(8)) must be removed to gain access to the grease nipple; three countersunk slotted screws secure the plate.
- 38 To lubricate the azimuth scale (Fig 5(1)) move the vehicle heading scaler lens (2) clear of the scale, unscrew the six socket headed screws (7) securing the tower top plate (6) and lift the plate clear, the scale ring can now be removed. Clean the ring, lightly smear with grease, and replace. Replace the top plate and tighten the screws progressively in a clockwise sequence.
- 39 During the appropriate periodic maintenance as detailed in AESP 2350-T-250-601, the following maintenance tasks are to be carried out:

**CAUTION**

**EQUIPMENT DAMAGE.** Excessive use of lubricating oil in desert conditions will cause an accumulation of sand on lubricated surfaces. Use the minimum amount of oil to achieve the necessary lubrication and protection.

- 39.1 Clean and oil exposed surfaces of the mortar mount.
- 39.2 Using clean water and lint free cloth wash and dry exposed glass surfaces of sighting equipment - do not touch the surfaces with fingers.
- 39.3 Grease the lubricators (Fig 12) with the specified grease.

**NOTE**

Remove the access panel (Fig 12(4)) to gain access to the second turntable lubricator.

- 39.4 Check security of all bolts and tighten where necessary.
- 39.4.1 Remove each dust cover and check each has a vent hole that is unblocked.
- 39.4.2 Check the security of the base plate mounting bolts; if any are loose, refer to the appropriate maintenance personnel.
- 39.5 Grease the traverse gear ring (remove the access panel (Fig 12(4)) from the platform for access)



REDACTED

Fig 12 Location of mortar mount lubricators

### BOMB RACKS

40 The bomb racks are designed to accept twin bomb containers, the lugs formed for the carrying straps fitting in pairs of guide channels (Fig 13(2) and (3)).

41

42 Each tier of containers is secured in the racks by retaining plates (6) operated by a handle (7). The handles are retained in the secured position by locking pawls (8), which engage the end plate.

43 The extra containers on the pannier rack are retained in their guides by tongues welded to a locking bar (4). The bar is locked in the securing position by tightening the cap nut (Fig 14(6)). The locking nut is shouldered on the end face and locates in a keyhole slot in the bar hinge plate.

44 Two bomb containers (Fig 15(3)) can be hung on a bracket (1) mounted on the rear door (2); these are only accessible when the rear door is open.

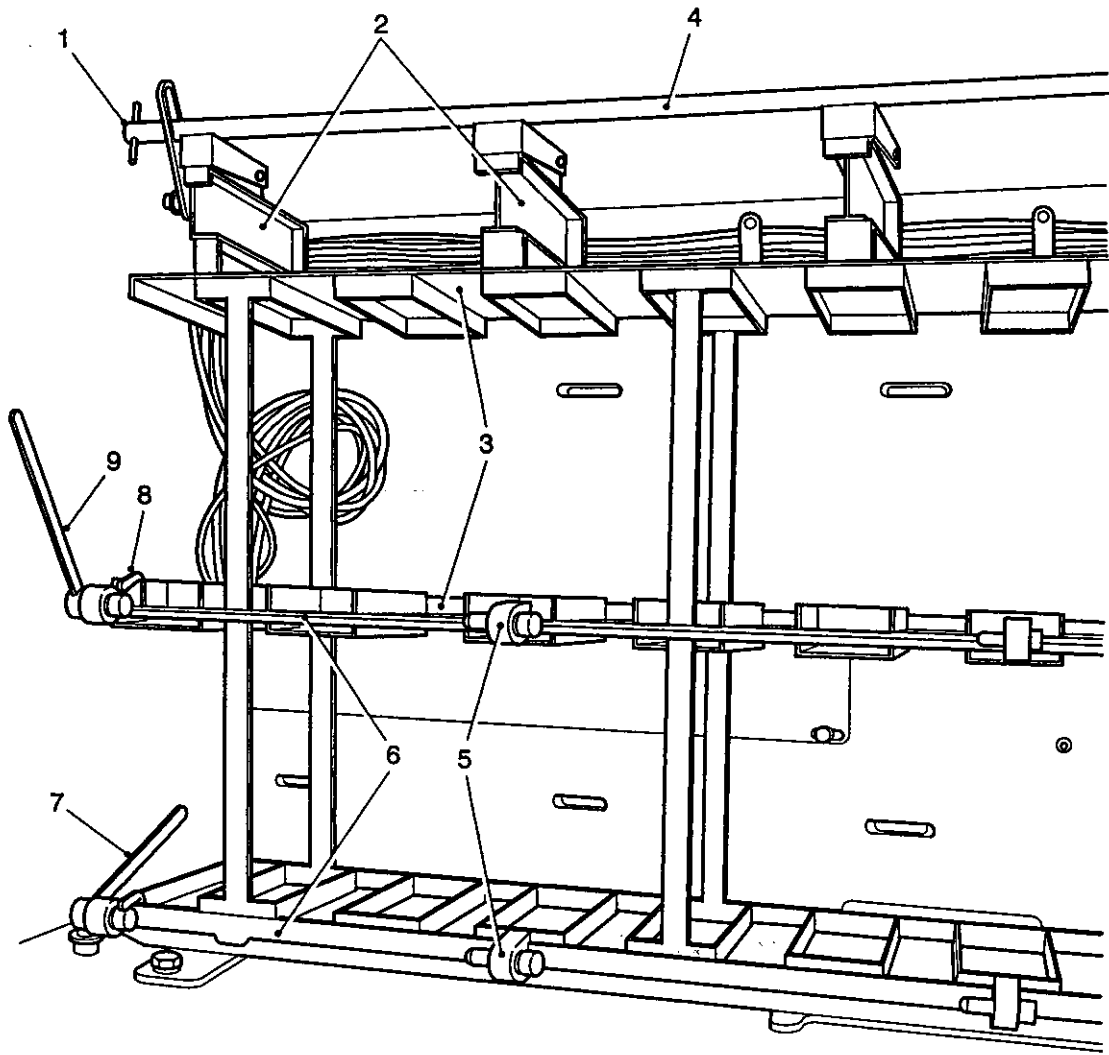

432/136

- |   |                |   |                            |
|---|----------------|---|----------------------------|
| 1 | Locking nut    | 6 | Container retaining plates |
| 2 | Guide channels | 7 | Locking handle (locked)    |
| 3 | Guide channels | 8 | Locking pawl               |
| 4 | Locking bar    | 9 | Locking handle (open)      |
| 5 | Bearing blocks |   |                            |

Fig 13 Pannier bomb rack

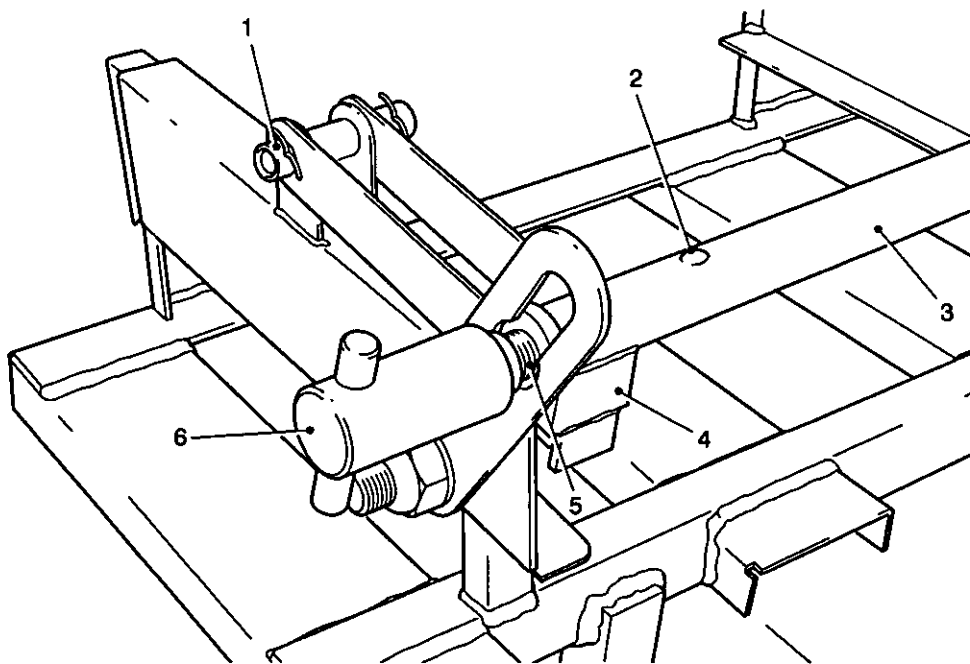

432/137

- |   |                     |   |             |
|---|---------------------|---|-------------|
| 1 | Hinge pin           | 4 | Tongue      |
| 2 | Rod retaining screw | 5 | Rod         |
| 3 | Locking bar         | 6 | Locking nut |

Fig 14 Locking bar (pannier rack)

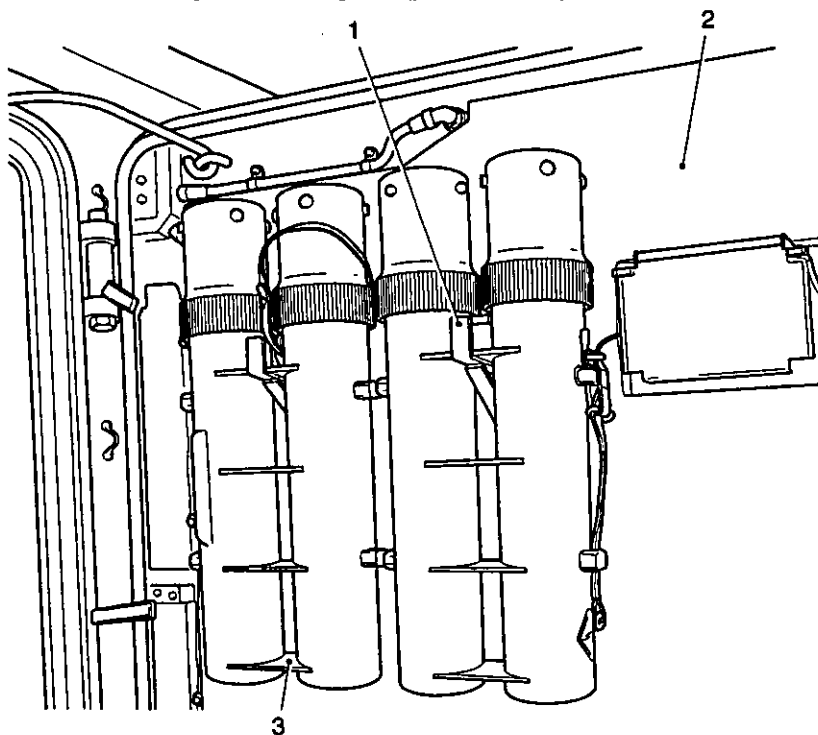

432/138

- |   |           |   |                 |
|---|-----------|---|-----------------|
| 1 | Bracket   | 3 | Bomb containers |
| 2 | Rear door |   |                 |

Fig 15 Rear door bomb stowage



## STOWAGE GRILLES

45 The grilles are provided for the retention of loose items of stowage on the pannier sill. Each grille (Fig 16(3)) can be removed separately by slackening the wing nuts (1), lifting the grille sufficiently to clear the channel (2) then withdrawing it and lowering it clear. When replacing a grille, engage the top of the grille under the wing nuts before lowering the grille into the channel. Secure the grille by tightening the wing nuts.

## TRANSVERSE RAIL

46 The transverse rail (Fig 17(5)) retains loose stowage in the space below the rear bomb rack. To remove the rail, unclip the locking pin safety clips (6), withdraw the locking pins (1) and insert them in the staples (7), then lift the rail clear. Replace in the reverse sequence of operation.

## DOUBLE SEAT

47 The double seat is supported by a bracket bolted to the hull lower side plate and two tubular legs hinged to the hull floor. A quick release drop endpin is provided to connect the seat to the side plate bracket and when the pin is withdrawn, the seat can be swung aside to give access to the ventilation batteries.

## SINGLE SEAT

48 The single seat (Fig 16(4)) is fitted in place of the front right personnel seat. It is supported by a single hinge bracket and can be held in the raised position by linked struts.

## WEAPON STOWAGE

49 Stowage facilities for the driver and commander's weapons, are provided by, spring clips mounted on the power pack pannier sill.

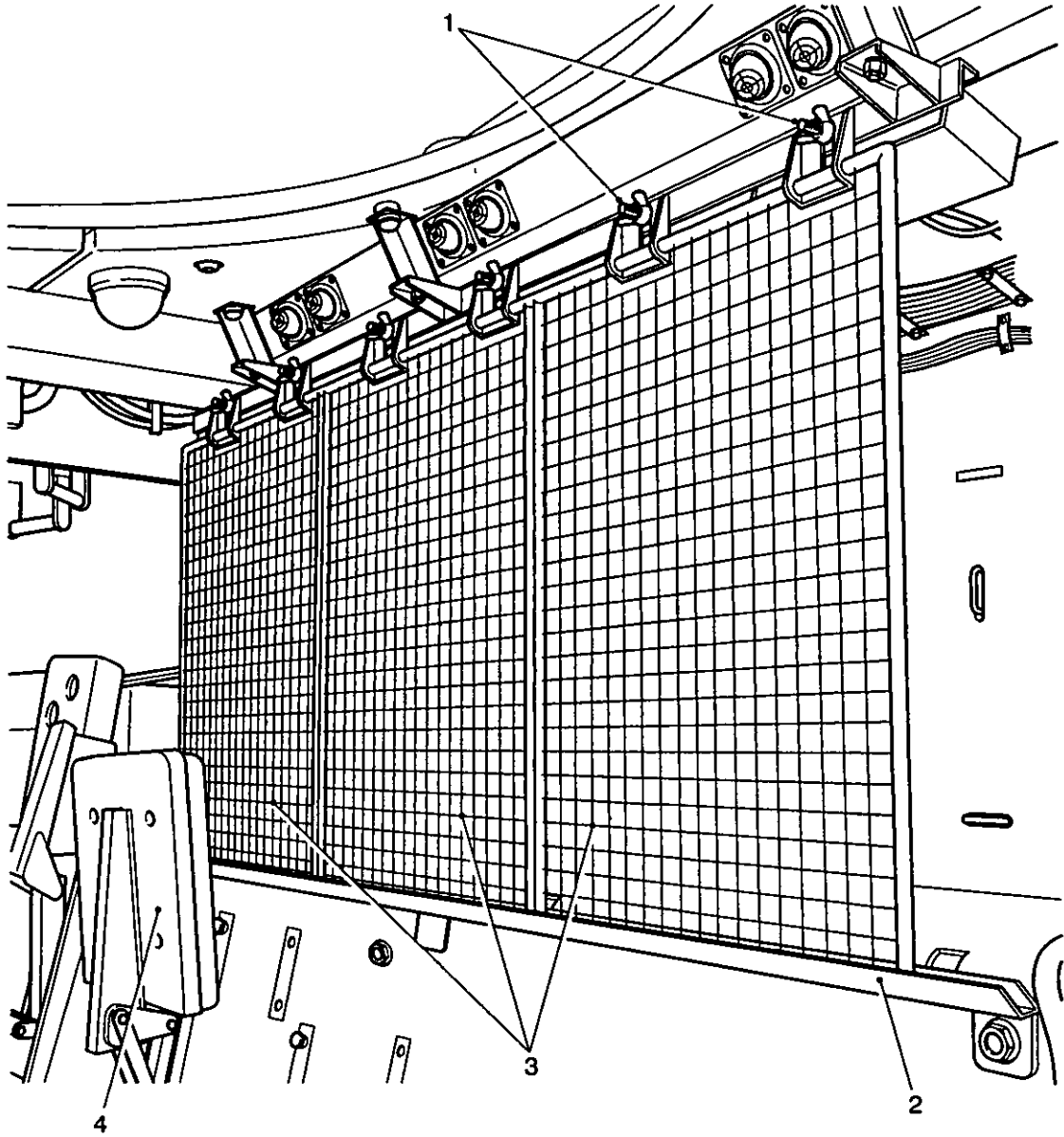

430/20149

- 1 Wing nuts
- 2 Channel

- 3 Grilles
- 4 Single seat

Fig 16 Stowage grilles

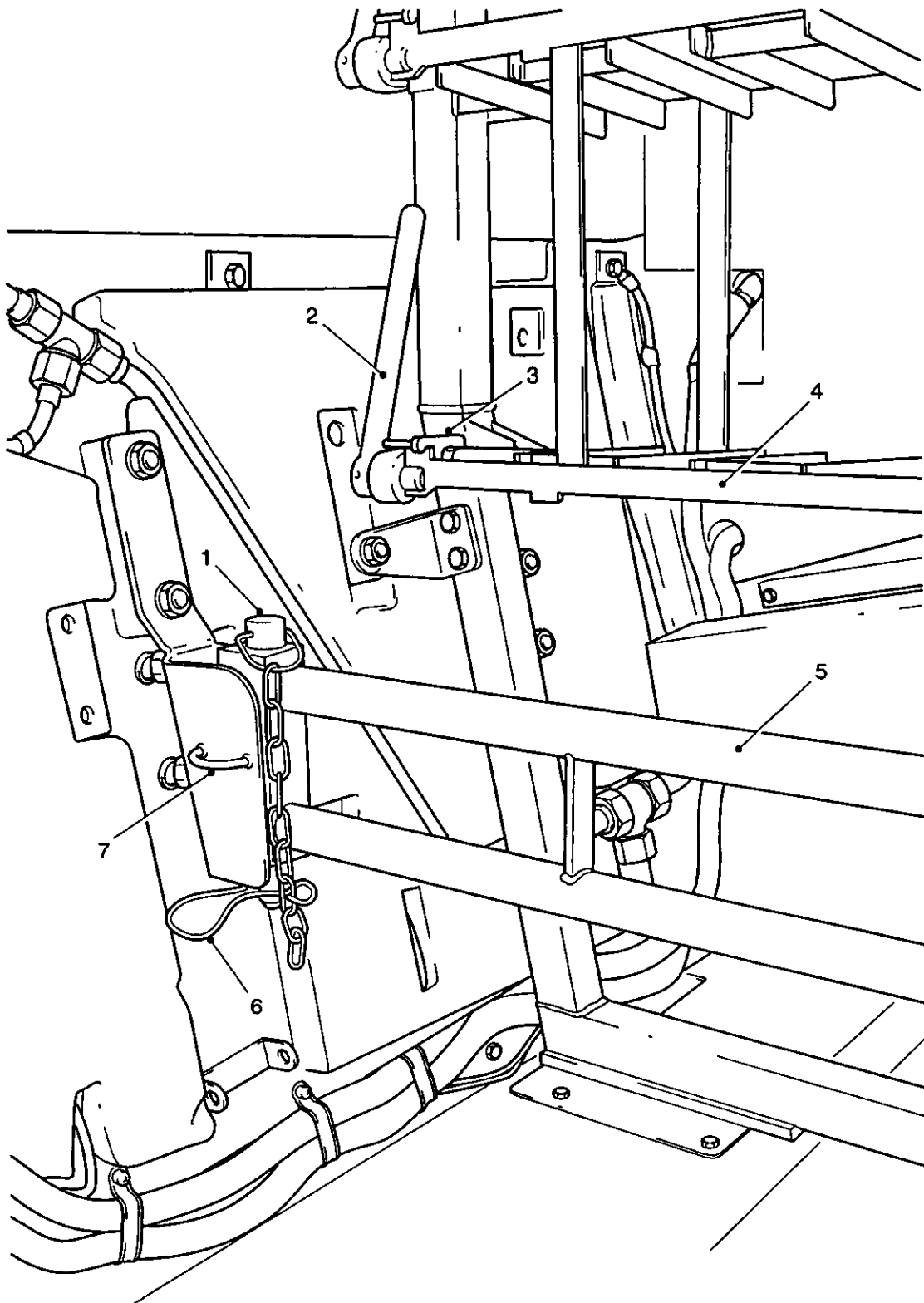

432/140

- |   |                           |   |                 |
|---|---------------------------|---|-----------------|
| 1 | Locking pin               | 5 | Transverse rail |
| 2 | Locking handle            | 6 | Safety clip     |
| 3 | Locking pawl              | 7 | Staple          |
| 4 | Container retaining plate |   |                 |

Fig 17 Transverse rail

**CHAPTER 3-5**  
**CARRIER ROLE**  
**CONTENTS**

Para

- 1 General
- 4 Pannier grilles
- 6 Under-seat grilles
- 9 Weapon rack
- 10 Cooking vessel platform
- 14 Cooking vessel harness

Fig

Page

- |   |                                      |     |
|---|--------------------------------------|-----|
| 1 | Stowage grilles and weapon rack..... | 2   |
| 2 | Cooking vessel platform .....        | 3/4 |

**GENERAL**

- 1 The stowage kit provides supplementary stowage facilities when the vehicle is to be used in the basic carrier role.
- 2 The kit comprises pannier sill and under-seat wire mesh grilles, a weapon rack and a platform on which the cooking vessels can be stowed and operated.
- 3 The kit is common to all marks of vehicle and the installation is detailed in AESP 2350-T-251-412 Inst Instr No. 5.

**Pannier grilles**

- 4 Each pannier sill is provided with three separate grilles. The right side grilles and the two rear left side grilles (Fig 1(4)) are interchangeable, but the forward left pannier grille (11) is longer in length and has one corner relieved.
- 5 The grilles can be removed individually by slackening the wing nuts (12) and lifting the grille sufficiently to clear the channel (5), and then withdrawing it and lowering it clear of the wing nuts. When replacing a grille, engage the top of the grille under the wing nuts before lowering the grille into the channel. Secure the grille by tightening the wing nuts.

**Under-seat grilles**

- 6 The wire mesh grilles (9) and (10) under the seats retain loose items stowed on the floor; they also provide an anchorage for personal weapons which are attached to the grilles by means of nylon webbing straps (8). The straps are fitted with self-locking buckles.
- 7 Access to the space behind the grilles is achieved by raising the seats.
- 8 The right side grille is retained in position by key plates which fit into the floor strap recesses, by hooked struts (7) and by being bolted to the floor by a diagonal strut (6) at the forward end. The left side grille is fitted with key plates and hooked struts only and it is shorter in length than the right one.

**Weapon rack**

- 9 The weapon rack (3), which is mounted on the power pack bulkhead, provides stowage brackets for the General Purpose Machine Gun (GPMG).

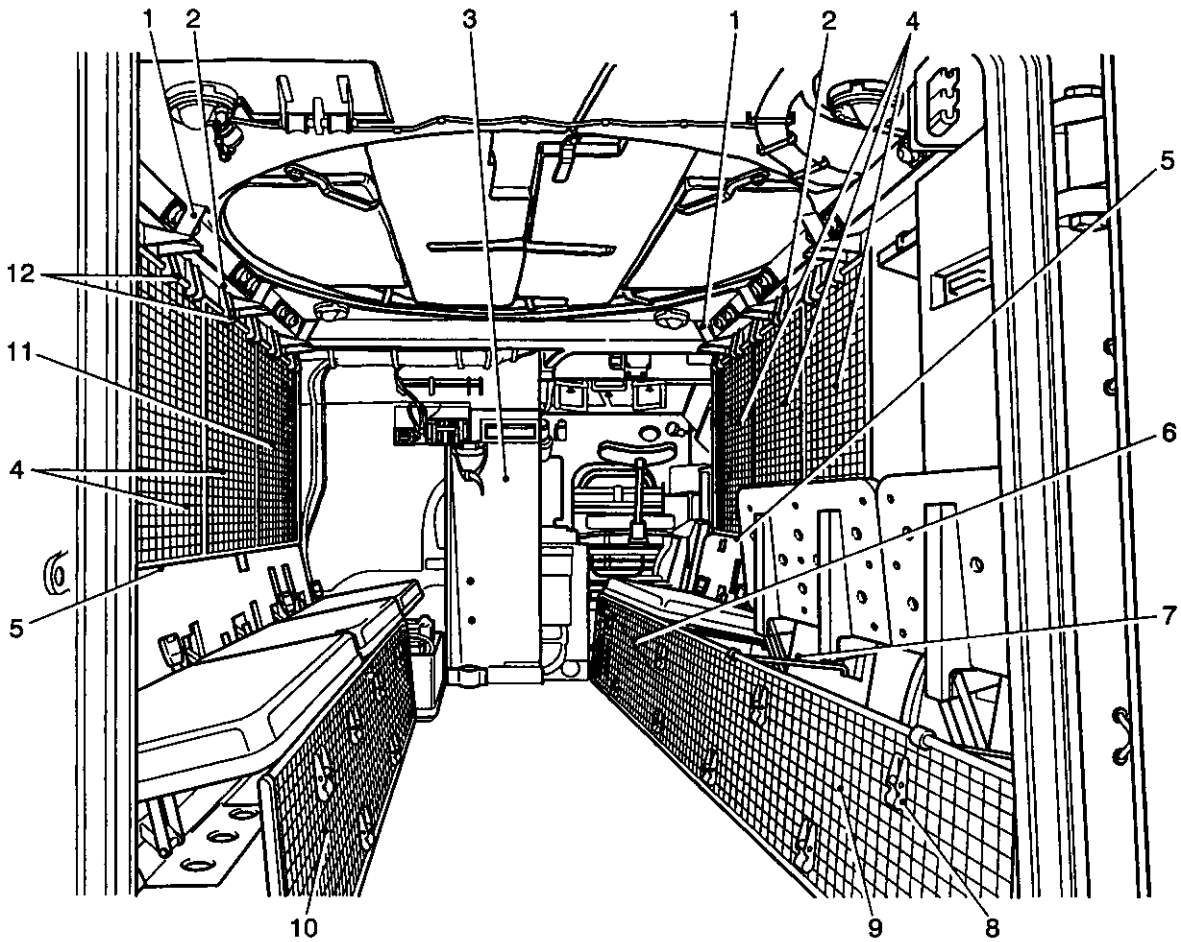

430/20150

1	Angle bracket support	7	Hooked strut
2	Angle bracket	8	Strap
3	Weapon rack	9	Under-seat grille, right
4	Pannier grille	10	Under-seat grille, left
5	Channel	11	Pannier grille
6	Diagonal strut	12	Wing nuts

Fig 1 Stowage grilles and weapon rack

### Cooking vessel platform

10 The cooking vessel platform (Fig 2) is bolted to the rear door. It provides a secured position in which up to two cooking vessels can be operated.

11 The platform consists of a back plate (Fig 2(3)) to which a hinged shelf (5) and vessel-securing strap (4) are attached.

12 The platform shelf can be raised to rest against the back plate and retained in this position by means of a drop-plate pin (6) inserted through the hasp (2).

13 The vessel-securing strap (4) is made fast at one end and provided with an open hook at the other. The buckle is of the quick release type with an over centre tensioning device.

**Cooking vessel harness**

14 The cable harness (Fig 2(1)) for the cooking vessels follows the existing cable runs in the vehicle to the sockets (11) mounted on the hull rear plate, adjacent to the rear door. Extra cable clips using existing bolts secure the harness. The harness plugs are left permanently plugged in to the cooking vessel sockets of the the Distribution Panel No. 6. Connection and disconnection of the harness must be made at the cooking vessel, by means of the push/pull off connector.

**NOTE**

The cooking vessel can only be used when the generators are "on line".

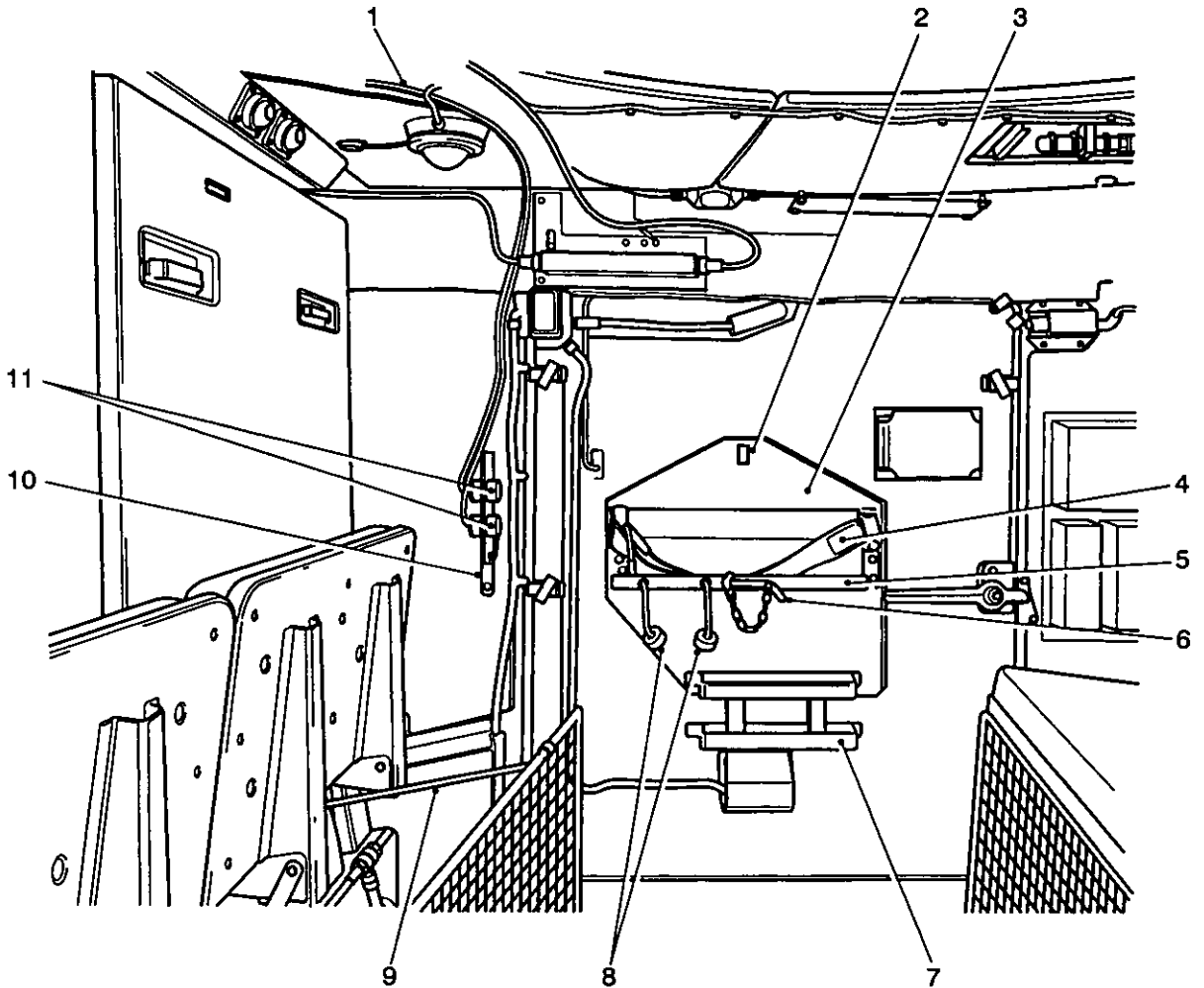

430/20151

- |   |                       |    |                            |
|---|-----------------------|----|----------------------------|
| 1 | Cable harness         | 7  | First aid box holder       |
| 2 | Hasp                  | 8  | Cooking vessel socket caps |
| 3 | Back plate            | 9  | Hooked strut               |
| 4 | Vessel securing strap | 10 | Connector socket brackets  |
| 5 | Shelf                 | 11 | Sockets                    |
| 6 | Drop-plate pin        |    |                            |

Fig 2 Cooking vessel platform



**CHAPTER 3-6**  
**COMMAND ACOUSTIC SOUND-RANGING PROGRAMME (ASP) ROLE**  
**CONTENTS**

**Para**

- 1 General
- 2 Communication equipment
- 3 Descriptions
- 7 Driver's compartment
- 8 Commander's compartment
- 10 ASP Command post compartment
- 14 Sliding table assemblies
- 15 Extending the sliding table
- 16 Retracting the sliding table
- 17 Personnel seats
- 18 Maintenance
- 19 Light fittings
- 20 Document boxes
- 21 Brush guard

**Fig**

**Page**

1	Schematic layout of ASP Command post compartment .....	5
2	Sliding table .....	6
3	Brush guard .....	6



**GENERAL****NOTE**

Unless stated, the equipment is common to all marks of vehicle, so where illustrations depict the equipment fitted to a mark of vehicle that is not relevant, the background can be ignored.

1 The Command ASP role consists of equipment required to convert the personnel compartment into an office (see Fig 1) containing ASP, tables, a bench seat on the left hand side of the crew compartment, and extra lighting. Additional radio installation and cables are supplied in separate kits.

**COMMUNICATIONS EQUIPMENT**

2 Fig 1 is a schematic diagram detailing the communication equipment installed in the ASP Command post compartment, it also details the equipment fitted in the commander's and driver's stations, and is included for reference only. Full details of the operation of the equipment is detailed in relevant Bowman Radio Communication Interactive Electronic Technical Publication (IETP).

**Description**

**REDACTED.**

## ASP Command post compartment

**REDACTED**

12 An equipment table is fitted on the rear of the RHS of the platform mounts the BOWMAN Headquarters printer (HQP) (20). The BOWMAN PDU-C power distribution unit (17) is positioned on the top of this equipment table, with the UDT (18) sliding desk arrangement fitted in front of this.

13 Two BOWMAN LED type strip lights are provided, mounted on a rail (21) running the majority of the length of the crew area, along the vehicle centre line.

### SLIDING TABLE ASSEMBLIES

14 The ASP Command post compartment is equipped with a sliding table assembly (Fig 2) which provides a platform for retaining two User Data Terminals (UDT). The sliding table can be secured in the extended or retracted position.

#### Extending the sliding table assembly

15 The sliding table has two spring loaded locking handles, the smaller (forward) table only has one spring loaded locking handle.

15.1 No further information at time of printing.

#### Retracting the sliding table assemblies

16 The procedure to retract the sliding table assemblies is the reverse of the procedure detailed for extending.

### PERSONNEL SEATS

17 Three double seats (Fig 1 (22)) are fitted along the LH side of the Command ASP compartment. In the raised position, the seats are held by a double link, which moves over centre against the side plate. Each seating place is provided with a lap belt.

#### Maintenance

18 User maintenance for the personnel seats is restricted to checking the security of the seat mounting fixtures, ensuring the locking catch mechanisms operate to retain the seats in the vertical and horizontal positions, and all hinges and locking catches are lightly oiled.

### LIGHT FITTINGS

19 LED light stripes (Fig 1 (21)) are mounted along the centre of the crew compartment roof so that the ASP and User Control Devices (UCD) can be illuminated. The supply is controlled by switch No. 2 on the auxiliary junction box.

**DOCUMENT BOXES**

20 Five document boxes are bolted to the inside of the vehicle, one on the rear door, one, on either side of the door on the rear plate and one on each outer segment of the mortar hatch. Each box has a hinged lid which when closed is retained by a spring clip at each side. Handles are provided for opening the lids.

**BRUSH GUARD**

**REDACTED**

22 The procedure to secure the front cover is the reverse of opening.



No information available at time of printing

Fig 2 Sliding table

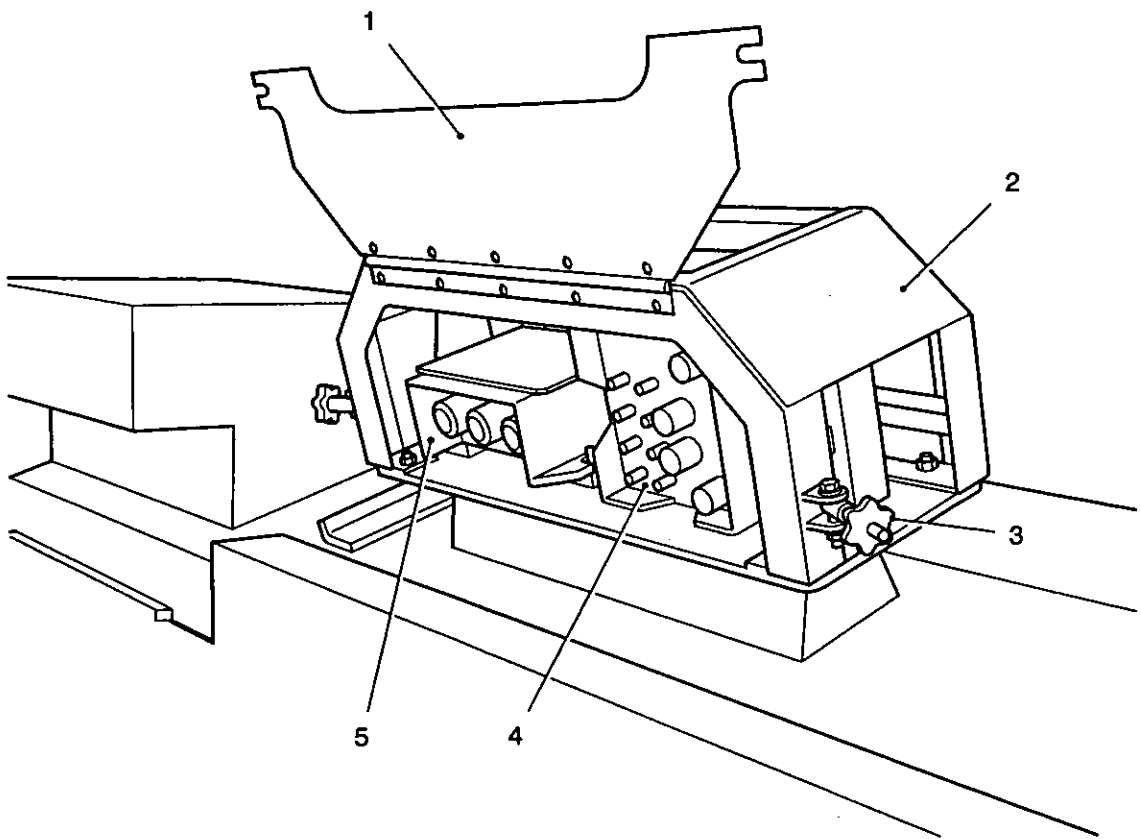

432/20176

- 1 Front cover
- 2 Brushguard
- 3 Clamping knob

- 4 VIP (FFLB)
- 5 BEOM

Fig 3 Brush guard

**CHAPTER 4**  
**DESTRUCTION OF EQUIPMENT**  
**CONTENTS**

Para

- 1 Mandatory directive
- 3 Degree of damage
- 5 Spare parts
- 6 Means and procedures
- 8 Mechanical
- 9 Burning (WARNING)
- 10 Gunfire (WARNING)
- 11 Priorities

Table

Page

1	Priorities for destruction .....	3/4
---	----------------------------------	-----

**MANDATORY DIRECTIVE**

- 1 Destruction of the equipment, when subject to capture by the enemy, must be undertaken by the user arm **ONLY WHEN**, in the judgement of the unit commander concerned, such action is necessary in accordance with orders of, or policy established by, the Army or Divisional Commanders.
- 2 The reporting of the destruction of equipment is to be carried out through command channels.

**Degree of damage**

**REDACTED**

MEANS AND PROCEDURES

REDACTED

Priorities

REDACTED



UNRESTRICTED

UNRESTRICTED

**COMMENT(S) ON AESP\***

To: DCCS  
BFPO 794

From: .....  
.....  
.....

<b>Sender's Reference</b>	<b>BIN Number</b>	<b>Date</b>
<b>AESP* Title:</b>		
<b>Chapter(s)/Instruction</b>	<b>Page(s)/Paragraph(s)</b>	
If you require more space please use the reverse of this form or a separate piece of paper. <b>Comment(s):</b>		

Signed: ..... Telephone No.: .....  
Name (Capitals): ..... Rank/Grade: ..... Date: .....  
X .....

**FOR AESP\* SPONSOR USE ONLY**

To: ..... From: .....  
.....  
.....

Thank you for commenting on AESP\*: .....

Your reference: ..... Dated: .....

<b>Action is being taken to:</b>	<b>Tick</b>		<b>Tick</b>
Issue a revised/amended AESP*		Under investigation	
Incorporate comment(s) in future amendments		No action required	
<b>Remarks</b>			

Signed: ..... Telephone No.: .....  
Name (Capitals): ..... Rank/Grade: ..... Date: .....

\*AESP or EMER

UNRESTRICTED

UNRESTRICTED