

#### CONDITIONS OF RELEASE

- 1 This information is released by the UK Government for Defence purposes only.
- 2 This information must be afforded the same degree of security protection as that afforded to information of an equivalent security marking originated by the recipient Government or as required by the recipient Government's security regulations.
- 3 This information may be disclosed only within the Defence Department of the recipient Government, except as otherwise authorized by the Ministry of Defence (Army).
- 4 This information may be subject to privately owned rights.

## CARRIER, PERSONNEL, FULL TRACKED, FV432 MK 2 AND 2/1

### MODIFICATION INSTRUCTIONS AND INDEX

THIS DOCUMENT IS THE PROPERTY OF HER BRITANNIC MAJESTY'S GOVERNMENT, and is issued for the information of such persons only as need to know its contents in the course of their official duties. Any person finding this document should hand it in to a British forces unit or to a police station for its safe return to the MINISTRY OF DEFENCE (Dsy (Pol)), MAIN BUILDING, WHITEHALL, LONDON SW1A 2HB with particulars of how and where found. THE UNAUTHORIZED RETENTION OR DESTRUCTION OF THIS DOCUMENT IS AN OFFENCE UNDER THE OFFICIAL SECRETS ACTS OF 1911-1989. (When released to persons outside Government service, this document is issued on a personal basis and the recipient to whom it is entrusted in confidence, within the provision of the Official Secrets Acts 1911-1989, is personally responsible for its safe custody and for seeing that its contents are disclosed only to authorized persons).

BY COMMAND OF THE DEFENCE COUNCIL

Ministry of Defence  
Issued by  
DEFENCE LOGISTICS ORGANISATION

AMENDMENT RECORD

Amdt No.	Incorporated By (Signature)	Date
1	Incorporated	Apr 08
2		
3		
4		
5		
6		
7		
8		
9		
10		
11		
12		
13		
14		
15		
16		
17		
18		
19		
20		
21		
22		
23		
24		
25		
26		
27		
28		
29		
30		
31		

Amdt No.	Incorporated By (Signature)	Date
32		
33		
34		
35		
36		
37		
38		
39		
40		
41		
42		
43		
44		
45		
46		
47		
48		
49		
50		
51		
52		
53		
54		
55		
56		
57		
58		
59		
60		
61		
62		

**PREFACE**

Sponsor:  
LAS IPT DE & S  
File ref:

Publication Agency:  
LAS IPT DE & S  
Project No: 97/41c/217(243)  
File ref: Admin 281

**INTRODUCTION**

- 1 The Publication Agency is responsible for the allocation of instruction numbers.
- 2 All modification instructions as issued are to be recorded in manuscript by the recipient on the Numerical Modification Instruction Index provided. Amendments to individual instructions are to be recorded on the instruction amendment record. All extant instructions and amendments can be found listed in the main AESP index.

**NOTE**

The Publication Agency is responsible for the preparation and maintenance of the Instruction Index and will advise the Distribution Authority on the issue of completed and subsequent blank index pages necessary.

- 3 Service users should forward any comments on this publication through the channels prescribed in AESP 0100-P-011-013. An AESP Form 10 is provided after the preliminary pages of this publication; it should be photocopied and used for forwarding comments on this AESP to DLO DTS.

- 4 AESPs are issued under Defence Council authority and where AESPs specify action to be taken, the AESP will of itself be sufficient authority for such action and also for the demanding of the necessary stores.

**MODIFICATION INSTRUCTION INDEX**

Priority (Pty) is shown as: Immediate: I Routine: R

Instr No. (1)	Pty (2)	Page Nos. (3)	Amend-ment No. (4)	Subject (5)	Approval No./Remarks (6)
1	(See Col 6)		1	EMER TV E 107/2 Mod Instr No. 1 to No. 142	Priority as detailed in each instruction
2	R	1-4		Fuel tank filter	43/0/0046
3	I	1-4 Ax A 1/2		High visibility marker boards	43/2/0017
4	R	1-5/6		Rear floor plate	43/0/0060
5	I	1-5/6		Introduction of crew lap belts	MAE 43/2/0020 MAE 43/2/0023
6	I	1-4	2	Boiling vessel power harness connections	43/2/0030
7	I	1-4		Hatch Locking Arm (Commander's)	43/2/0034

(continued)

**MODIFICATION INSTRUCTION INDEX (continued)**

Instr No. (1)	Pty (2)	Page Nos. (3)	Amend-ment No. (4)	Subject (5)	Approval No./Remarks (6)
8					
9					
10					
11					
12					
13					
14					
15					
16					
17					
18					
19					
20					
21					
22					
23					
24					
25					
26					
27					
28					
29					
30					
31					
32					
33					
34					
35					
36					
37					
38					
39					
40					
41					

**COMMENT(S) ON AESP\***

To: DLO DTS 3.2  
Ha-Ha Road  
Woolwich  
LONDON SE18 4QF

From: .....  
.....  
.....  
.....

<b>Sender's Reference</b>	<b>BIN Number</b>	<b>Date</b>
<b>AESP Title:</b>		
<b>Chapter(s)/Instruction</b>	<b>Page(s)/Paragraph(s)</b>	
If you require more space, please use the reverse of this form or a separate piece of paper. <b>Comment(s):</b>		

Signed: ..... Telephone No: .....

Name (Capitals): ..... Rank/Grade: ..... Date: .....

✕ .....

**DLO DTS 3.2 USE ONLY**

To: .....  
.....  
.....  
.....

From: DLO DTS 3.2  
Ha-Ha Road  
Woolwich  
LONDON SE18 4QF

Thank you for commenting on AESP .....

Your reference ..... Dated: .....

<b>Action is being taken to:</b>	<b>Tick</b>	<b>Tick</b>
Issue a revised/amended AESP		Under investigation
Incorporate comment(s) in future amendments		No action required
<b>Remarks</b>		

Signed: ..... Telephone No: .....

Name (Capitals): ..... Rank/Grade: ..... Date: .....

\* AESP or EMER

AESP Form 10 (Issue 4.2 dated Apr 00)

**CARRIER, PERSONNEL, FULL TRACKED, FV432 MK 2 AND 2/1**

**MODIFICATION INSTRUCTION NO. 1**

**COMPLETELY REVISED**

Sponsor:  
DGES(A)

Publication Agency:  
DLO Andover  
Project No.: 97/41c/217(243)  
File ref: Admin 281

**AMENDMENT RECORD**

Amdt No.	Incorporated By (Signature)	Date
1		
2		
3		

Amdt No.	Incorporated By (Signature)	Date
4		
5		
6		

**SUBJECT: EMER TV E107/2 Modification Instructions No. 1 to No. 142**

**INTRODUCTION**

1

- 1.1 The EMER decade (TV E 100/2 to E 109/2) that supports the FV432 is to be cancelled and replaced by AESP 2350-T-251-octad.
- 1.2 This AESP Modification Instruction No. 1 is a complete issue of EMER TV E 107/2 Modification Instructions No. 1 to No. 142 issued under the EMER system.
- 1.3 Subsequent Modification Instructions will be issued in AESP format, starting with Mod Instr No. 2.
- 1.4 Where the EMER TV E 107/2 Modification Instructions refer to an associated EMER TV E100 series publication, this information will be incorporated within the appropriate Modification Instruction.
- 1.5 Remove and retain EMER TV E 107/2 Modification Instructions No. 1 to No. 142 from the EMER folder.
- 1.6 Place this instruction in front of Modification Instructions removed at Sub-Para 1.5.
- 1.7 Open a new folder numbered 2350-T-251-811 and titled Carrier, Personnel, Full Tracked, FV432 MK 2 and 2/1 Modification Instructions, and place the EMER TV E 107/2 Modification Instructions within.
- 1.8 Limitations on use of equipment: As detailed within each Modification Instruction.

**APPLICABILITY**

2 FV432.

**REASON FOR MODIFICATION**

3 Code 6 - Publications changed from EMER to AESP format.

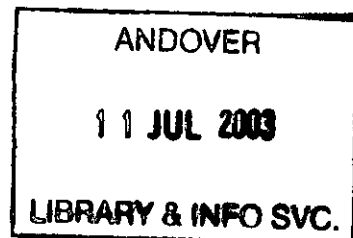

## PRIORITY

4 Routine.

## TABLE 1 MODIFICATION INSTRUCTION INDEX

Priority (Pty) is shown as:

Immediate unit: I/U  
Immediate field: I/FRoutine unit: R/U  
Routine field: R/F  
Routine base: R/B

## NOTE

\*Denotes stocks exhausted. These items are not automatically reprinted. Units should not demand these items without detailed justification.

Instr No. (1)	Issue No. (2)	Pages (3)	Pty (4)	Subject (5)	Approval No./ Remarks (6)
1*	1	1-2	R/U	Driver's instrument panel. <i>Cancelled</i>	21411
2*				CANCELLED	21414
3*				CANCELLED	
4*	1	1-2	R/U	Gearbox dipstick - modified. <i>Cancelled</i>	21391
5*				CANCELLED	
6*				CANCELLED	
7*				CANCELLED	
8*				CANCELLED	
9*				CANCELLED	
10*	1 1	0-01 1-7	R/U	Commander's periscope wiper. <i>Cancelled</i>	21384
11*				CANCELLED	

(continued)

TABLE 1 MODIFICATION INSTRUCTION INDEX (continued)

Instr No. (1)	Issue No. (2)	Pages (3)	Pty (4)	Subject (5)	Approval No./ Remarks (6)
12*				CANCELLED	
13*				CANCELLED	
14*				CANCELLED	
15*				CANCELLED	
16*				CANCELLED	
17				CANCELLED	
18*				CANCELLED	
19*				CANCELLED	
20*				CANCELLED	
21*				CANCELLED	
22*	1 1 2	0 1-4 5-8	R/U	Alternator No. 1 Mk 1 - new driving gear. <i>Cancelled</i>	21674
23*				CANCELLED	
24*				CANCELLED	
25*	1 1	0 1-2	R/U	Sprocket ring bolts. <i>Cancelled</i>	29312
26*				CANCELLED	
27*	1 1	1 1-4	R/U	Driver's switch No. 1 Mk 1. <i>Cancelled</i>	21440

(continued)



TABLE 1 MODIFICATION INSTRUCTION INDEX (continued)

Instr No. (1)	Issue No. (2)	Pages (3)	Pty (4)	Subject (5)	Approval No./ Remarks (6)
28*				CANCELLED	
29*				CANCELLED	
30*				CANCELLED	
31*				CANCELLED	
32*				CANCELLED	
33*	1 1	0 1-2	R/B	Fire warning system - additional clamps. <i>Cancelled</i>	21685
34*	1	1-4	R/U	Cupola machine gun mounting.	21539
35*				CANCELLED	
36*				CANCELLED	
37*	1 1	0 1-3	R/U	Hull floor plate - blanking plugs added.	21430
38*				CANCELLED	
39*				CANCELLED	
40*				CANCELLED	
41*				CANCELLED	
42*				CANCELLED	
43*	2	1-2	R/U	Power pack fuel pipes - re-routed. <i>Cancelled</i>	21669

(continued)

TABLE 1 MODIFICATION INSTRUCTION INDEX (continued)

Instr No. (1)	Issue No. (2)	Pages (3)	Pty (4)	Subject (5)	Approval No./Remarks (6)
44*	2	1-4	R/U	Radiator vent tube extended. <i>Cancelled</i>	29399/ 29400
45*				CANCELLED	
46*	1	1-2	R/U	Vehicle radio harness. <i>Cancelled</i>	26687
47*	1 1	0 1-2	R/U	Adaption of radio support tray. <i>Cancelled</i>	29403
48*				CANCELLED	
49*				CANCELLED	
50*				CANCELLED	
51*	1	1-5	R/U	Commander's seat - locking device. <i>Cancelled</i>	21552
52	2 1	1-2 3	R/U	Smoke discharger terminal box sealing.	29411
53*	2 1	1-2 3-4	R/U	Coolant PRV drain tube.	
54*				CANCELLED	
55*	1	1-2	R/B	Fuel tank clamps. <i>Cancelled</i>	29034
56*				CANCELLED	
57*	1	1-2	R/U	Power tool unit No. 2, Mk 1. <i>Cancelled</i>	21542
58*				CANCELLED	
59*	1	1-4	R/U	Exhaust silencer - new pattern. <i>Cancelled</i>	21629

(continued)

TABLE 1 MODIFICATION INSTRUCTION INDEX (continued)

Instr No. (1)	Issue No. (2)	Pages (3)	Pty (4)	Subject (5)	Approval No./ Remarks (6)
60*	1	1-5	R/U	Access plate for governor dipstick. <i>Cancelled</i>	29384
61*				CANCELLED	
62*				CANCELLED	
63*	1	1-3	R/U	Cupola periscope. <i>Cancelled</i>	29309
64*				CANCELLED	
65*				CANCELLED	
66*	1	1-2	R/U	Ventilation ducting. <i>Cancelled</i>	21478
67*	3	1-2	R/U	Power pack identification plate. <i>Cancelled</i>	29457
68*				CANCELLED	
69*	1	1-3	R/U	Track pad and mud deflectors. <i>Cancelled</i>	29356
70*				CANCELLED	
71*	1	1-2	R/B	Painting of ventilation ducting. <i>Cancelled</i>	29354
72*				CANCELLED	
73*				CANCELLED	
74				NOT USED.	
75*				CANCELLED	

(continued)

TABLE 1 MODIFICATION INSTRUCTION INDEX (continued)

Instr No. (1)	Issue No. (2)	Pages (3)	Pty (4)	Subject (5)	Approval No./ Remarks (6)
76*	2	1-2	R/U	Power pack - clipping of pipes. <i>Cancelled</i>	27047
77*	2 1	1-2 3-6	R/F	Strengthened power pack frame. <i>Cancelled</i>	21668
78*	1	1-3	R/U	Auxiliary charging panel. <i>Cancelled</i>	28116
79*	1	1-3	R/U	Ventilation equipment, pressure/suction gauge filter.	29395
80*				CANCELLED	
81*	1	1-5	R/U	Fuel tap access cover, locating clips. <i>Cancelled</i>	29412
82*				CANCELLED	
83*	1	1-4	R/U	Battery charge switch guard. <i>Cancelled</i>	29419/ 29420
84*	1	1-3	R/B	Prevention of damage to 5.1 in. fan motor relay. <i>Cancelled</i>	29490
85*				CANCELLED	
86*	1 1	1 1-10	R/U	Suspension (Air conditioning equipment). <i>Cancelled</i>	29629
87*	1 1	0 1-4	R/U	Locking of commander's hatch. <i>Cancelled</i>	29725
88*	1	1-4	R/U	Internal stowage - ambulance role. <i>Cancelled</i>	29650
89	2	1-12	R/B	Fitting of improved type engine cover sealing strips. <i>Cancelled</i>	29383/ 31028
90*	1	1-5	R/U	Commander's hatch, external locking device.	
91*				CANCELLED	

(continued)

TABLE 1 MODIFICATION INSTRUCTION INDEX (continued)

Instr No. (1)	Issue No. (2)	Pages (3)	Pty (4)	Subject (5)	Approval No./ Remarks (6)
92*				CANCELLED	
93*				CANCELLED	
94*				CANCELLED	
95*	1	1-4	R/B	Stowage facilities - various roles. <i>Cancelled</i>	30811
96*				CANCELLED	
97*				CANCELLED	
98*	1	1-3	R/U	Installation kit 81 mm mortar - traverse gearbox. <i>Cancelled</i>	30888
99*	1	1-6	R/B	Collapsible fuel funnel - outlet pipe coupling. <i>Cancelled</i>	31880
100*				CANCELLED	
101				CANCELLED	
102*				CANCELLED	
103*	1 1	0-01 1-6	R/F	Collector tank, access hatch fitting. <i>Cancelled</i>	30807
104*	1	1-2	R/U	Mortar mount - strengthened base plate socket. <i>Cancelled</i>	30786
105*	2	1-5	R/F	Casualty harness - fitting of cleats.	30731
106*				CANCELLED	
107*				CANCELLED	

(continued)

TABLE 1 MODIFICATION INSTRUCTION INDEX (continued)

Instr No. (1)	Issue No. (2)	Pages (3)	Pty (4)	Subject (5)	Approval No./ Remarks (6)
108				CANCELLED	
109				CANCELLED	
110				CANCELLED	
111				CANCELLED	
112				CANCELLED	
113				CANCELLED	
114	1 2	3 1-2	R/U	Strengthening of commander's seat pillar. <i>Cancelled</i>	
115	1 1	0 1-3	R/U	Engine compartment rear cover.	TSS 1501
116	3	1-5/6	R/U	Ventilation batteries - alternative.	31030
117				CANCELLED	
118	1	1-2	R/U	Weapon tray/track (internal stowage). <i>Cancelled</i>	31010
119				CANCELLED	
120				CANCELLED	
121				CANCELLED	
122				CANCELLED	
123				CANCELLED	

(continued)

TABLE 1 MODIFICATION INSTRUCTION INDEX (continued)

Instr No. (1)	Issue No. (2)	Pages (3)	Pty (4)	Subject (5)	Approval No./ Remarks (6)
124				CANCELLED	
125	1	1-4	R	Conversion to accept PADS. <i>Cancelled</i>	31096
126	3	1-11	R	Conversion to accept LRF LTM. <i>Cancelled</i>	31050 31054
127				CANCELLED	
128	2	1-6	R	Milan installation. <i>Cancelled</i>	20/2/0002
129	1	1-4	R	NAIAD Installation. <i>Cancelled</i>	20/2/0054 Aug 85
130	1	1-4	R	OTIS Support. <i>Cancelled</i>	20/2/0057 Nov 85
131				CANCELLED	
132				CANCELLED	
133				NOT USED.	
134				NOT USED.	
135				NOT USED.	
136	2	1-6	R	8 Metre mast mountings.	20/6/0001 Jun 92
137	2	1-6	I	2 Kg dry powder fire extinguisher.	43/0/0013 Jan 94
138	1	1-7	I	Crew air heater.	UOR(L)15/94 Nov 94
139	1	1-6	R	Mini pipe fascine lighting.	43/2/0004 Jul 95

(continued)

**TABLE 1 MODIFICATION INSTRUCTION INDEX (continued)**

Instr No. (1)	Issue No. (2)	Pages (3)	Pty (4)	Subject (5)	Approval No./ Remarks (6)
140	2	1-6	I	Driver's and commander's SA80 stowage.	43/2/0002 Aug 95
141	1	1-4	R	Concealment set array brackets.	43/2/0001/1 Jun 96
142	2	1-6	I	Amber Rotating Beacon.	43/2/0008 Nov 97
143					
144					
145					
146					
147					
148					
149					
150					
151					
152					
153					

**PUBLICATION AMENDMENTS**

**NOTE**

Necessary amendments will be issued separately.

5 Nil.



**CARRIER PERSONNEL, FULL TRACKED, FV432 MK 2 AND 2/1**

**MODIFICATION INSTRUCTION No. 7**

Sponsor:  
LAS IPT

Publication Agency:  
BAE Systems Land Systems  
Task No. 36042

**AMENDMENT RECORD**

Amdt No.	Incorporated by (Signature)	Date
1		
2		
3		

Amdt No.	Incorporated by (Signature)	Date
4		
5		
6		

**SUBJECT: Hatch Locking Arm (Commander's)**

Approval No. MAE 43/2/0034

**INTRODUCTION**

1 As a result of serious equipment failure when the commander's hatch locking arm (catch) failed to lock in the open position, causing injury to personnel, a modified catch is introduced.

**APPLICABILITY**

2 This modification is applicable to: FV432 Mk 2 AND 2/1.

**REASON FOR MODIFICATION**

3 Code 1 – To improve safety.

**PRIORITY**

4 Immediate.

**ESTIMATED TIME REQUIRED**

5 Embodiment: 2 Man hours.

**MODIFICATION IMPLEMENTATION PLAN**

6 This instruction is to be implemented by units authorised to undertake level 2 maintenance and above.

**Action required by**

7

7.1 Units holding subject vehicles:

7.1.1 Demand items listed in Para 8 and carry out this instruction.

7.1.2 Record completion details in vehicle documents.

7.2 All recipients of the AESP.

Add particulars to AESP 2350-T-251-811 Modification Instruction Index.

**Stores, Tools and Equipment**

8 The item numbers given in Para 8 are used as reference throughout this instruction.

8.1 Stores to be demanded

Item No.	NSN/Part No.	Designation	Qty Per eqpt
1	2510-99-736-7835	Catch – Commander's Hatch	1
2	5315-99-944-0176	Split Pin 3/32" dia x 7/8"lg	1

8.2 Stores to be discarded

Item No.	NSN/Part No.	Designation	Qty Per eqpt
3	2510-99-865-6527	Catch – Commander's Hatch	1
4	5315-99-944-0176	Split Pin 3/32" dia x 7/8"lg	1

8.3 Stores to be removed and refitted

Item No.	NSN/Part No.	Designation	Qty Per eqpt
5	5315-99-137-8940	Pin	1
6	5360-99-865-6518	Torsion Spring	1
7	5365-99-865-6517	Distance Piece	2
8	703000800910	Plain Washer 1/2" dia x 13 SWG	2

**Sequence of operations**

9 Refer to figs 1 & 2 and embody the modification as follows:

9.1 With the commander's hatch in closed position remove split pin (4) and washer (8) from one end of pin (5). Remove pin together with torsion spring (6), distance pieces (7), commander's hatch catch (3) and washer. Discard split pin and commander's hatch catch.

9.2 Refit torsion spring (6) and distance pieces (7) and fit replacement commander's hatch catch (1), securing in position with pin. Refit washer (8) and replace split pin (2).

**TESTING AFTER EMBODIMENT**

10 Ensure hatch locking arm operates correctly and cannot be "bounced" out of the locked open position.

**EFFECT ON WEIGHT**

11 Nil

**PUBLICATION AMENDMENTS**

12 Nil.

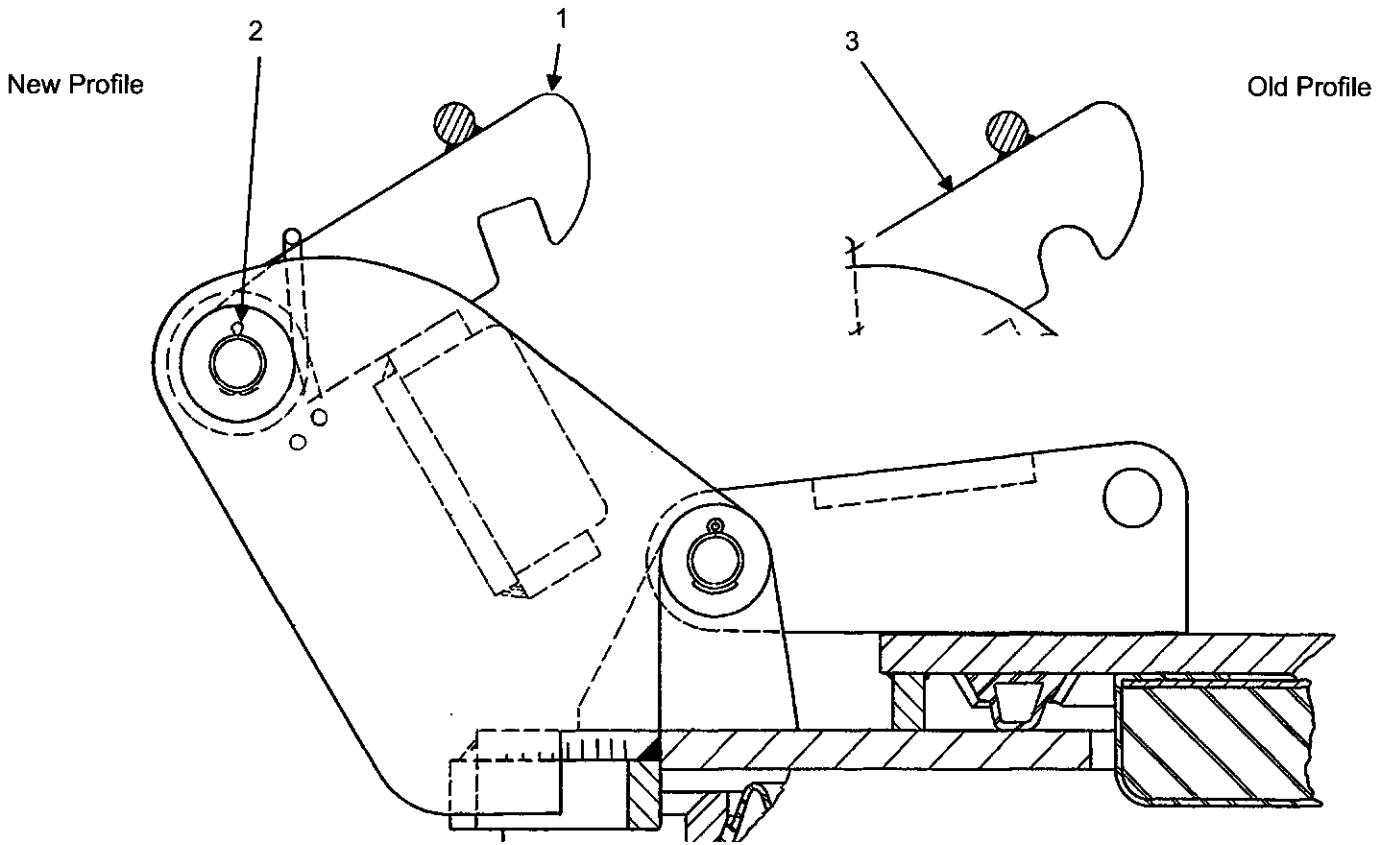

Fig 1 Catch Mechanism Side View

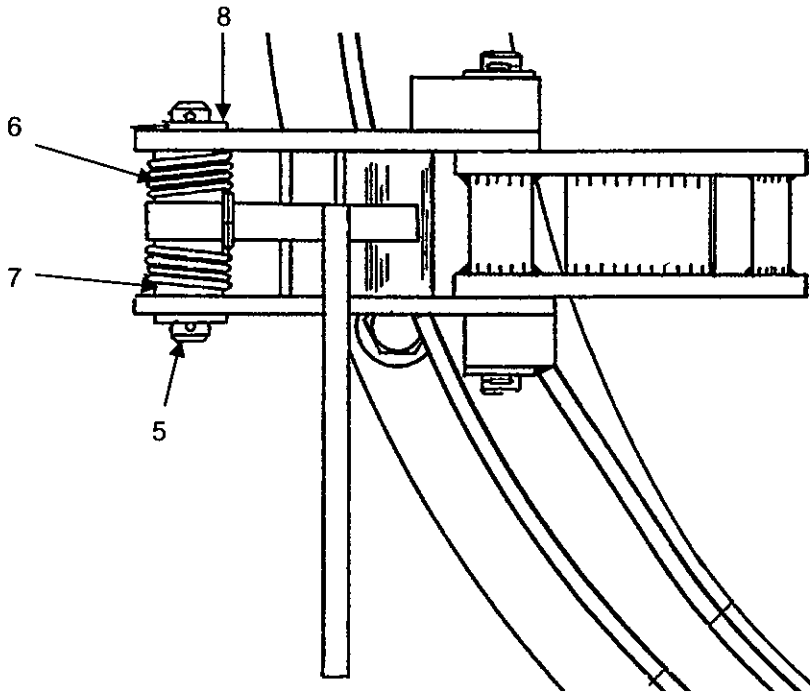

Fig 2 Catch Mechanism View from Above

**CARRIER, PERSONNEL FULL TRACKED,  
FV432 MK2 AND 2/1**

**MODIFICATION INSTRUCTION No. 8**

Sponsor:  
LAS IPT DE & S

Publication Agency:  
BAE Systems Land Systems  
(W&V) Ltd

Task No.: 36021

**AMENDMENT RECORD**

Amdt No.	Incorporated By (Signature)	Date
1		
2		
3		

Amdt No.	Incorporated By (Signature)	Date
4		
5		
6		

**SUBJECT: Modified generator frame for the lightweight field generator**

(Approval No. TBA )

**INTRODUCTION**

1 This modification instruction details the procedure to remove the old generator frame and the installation of a modified generator frame for the lightweight field generator.

**APPLICABILITY**

2 This modification instruction is applicable to FV432 Mk 2 AND 2/1.

**REASON FOR MODIFICATION**

3 Code 1 – to improve health and safety.

**PRIORITY**

4 Immediate.

**ESTIMATED TIME REQUIRED**

5

5.1 Removal/Refitting: TBA man-hour.

**MODIFICATION IMPLEMENTATION PLAN**

6 This modification instruction is to be implemented by units authorized to undertake level 2 maintenance and above.

**Action required by**

7

7.1 Holding units and establishments:

7.1.1 Examine equipment documents to see if this instruction is applicable.

7.1.2 On receipt of the stores, request level 2 maintenance and above to modify the equipment.

7.1.3 Record the modification subject and AESP details in the equipment documents.

7.2 Units authorised to complete level 2 maintenance and above:

7.2.1 When requested by users, obtain the items listed in Para 8.1 and carry out this instruction.

7.2.2 Record completed details of modification in vehicle documents (AB413).

7.3 All recipients of this instruction: Add particulars to AESP 2350-T-251-811 Modification Instruction Index.**Stores, tools and equipment**

8 The following items are to be demanded quoting this instruction as authority for demand and the registration number of vehicle for equipment held by user units.

8.1 Stores to be obtained:

Item No.	DMC	NSN/Part No.	Designation	Qty per eqpt
1		FV2200930	Generator Frame stowage bracket (Modified) Comprising	1
		FV2200931	Generator frame stowage bracket welded assy	1
		FV2281621	Clamp LH welded assy	1
		FV2281622	Clamp RH welded assy	1
		FV2200933	Bar	2
		WDS102-203 85	Hand screw c/w m10x85 lg allthread	2
	G1B	5315-99-952-8015	Pin cotter split	2

8.2 Stores to be discarded:

Item No.	DMC	NSN/Part No.	Designation	Qty per eqpt
2		FV2200930	Generator Frame stowage bracket (Unmodified)	1

## Sequence of operations

### NOTE

The item numbers used with Para 8 are used as reference throughout this instruction.

9 Refer to Fig 1 and carry out the modification as follows:

9.1 Ensure the vehicle is parked on firm level ground with the parking brake applied and the vehicle master switch in the OFF position.

9.2 When a lightweight field generator is to be installed and/or replaced on the vehicle locate and identify the type of generator frame fitted.

9.3 Remove the Generator from the generator frame using the roof mounted hoist.

9.4 If the generator frame is an unmodified type as shown in Fig 1(2) remove and discard the generator frame retaining all fixings.

9.5 Replace with a modified generator frame Fig 1(1) and secure using the fixings removed in Para 9.4.

9.6 Install the lightweight field generator using the hoist and secure in position with clamps and hand screws.

### Testing after embodiment

10 Nil

### EFFECT ON WEIGHT

11 Nil.

### PUBLICATION AMENDMENTS

12 Appropriate publications will be amended in due course.

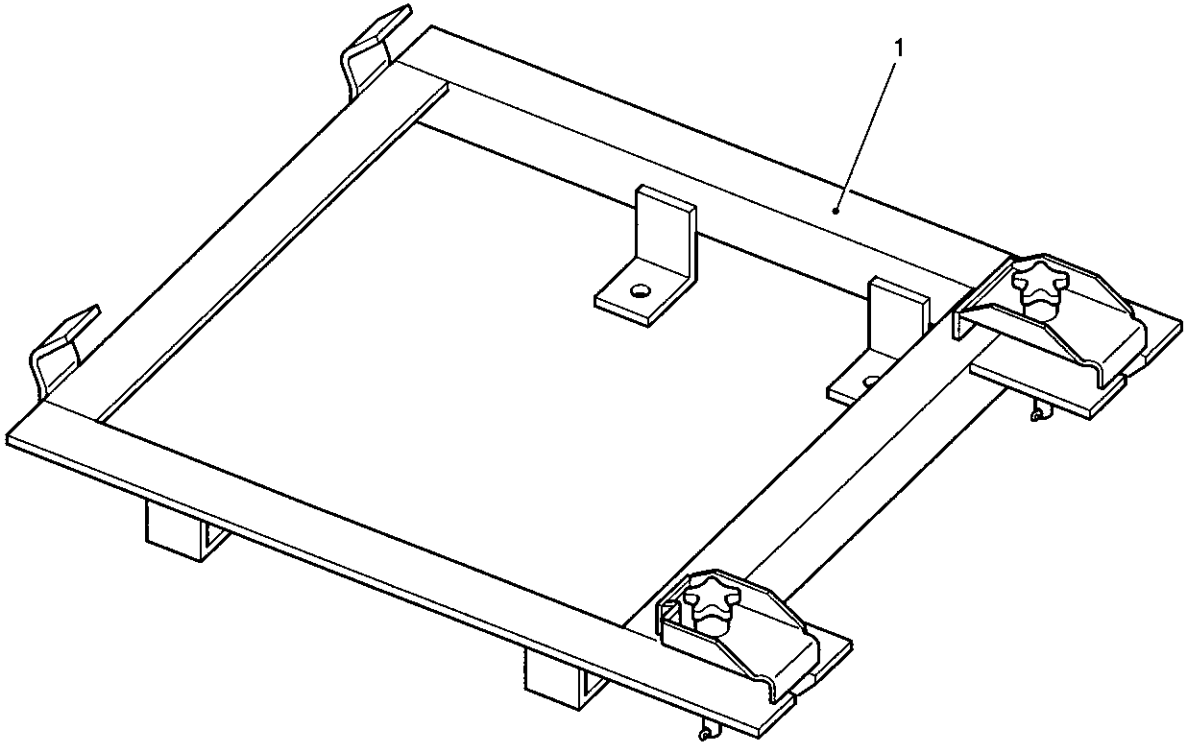

MODIFIED

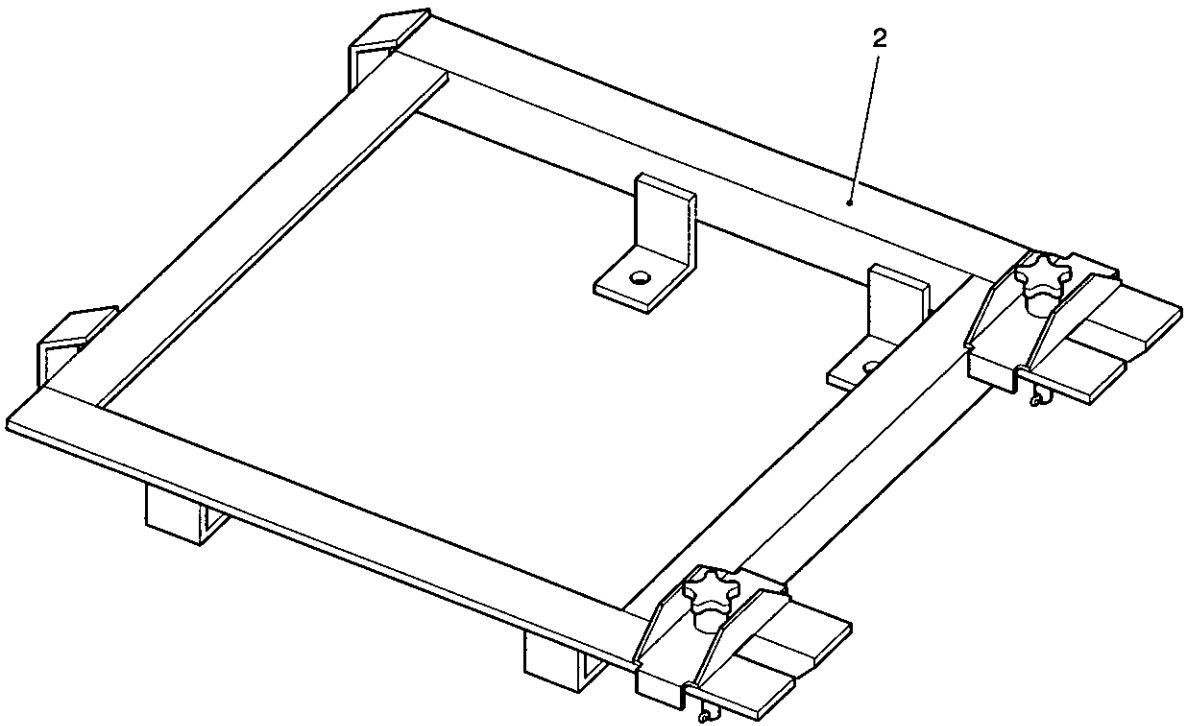

UNMODIFIED

430/80102

Fig 1 Generator frame stowage bracket



**CONDITIONS OF RELEASE**

- |   |   |   |   |
|---|---|---|---|
| 1 | This information is released by the UK Government for Defence purposes only.  | 3 | This information may be disclosed only within the Defence Department of the recipient Government, except as otherwise authorized by Ministry of Defence (Army). |
| 2 | This information must be afforded the same degree of protection as that afforded to information of an equivalent security marking originated by the recipient Government or as required by the recipient Government's security regulations. | 4 | This information may be subject to privately owned rights.  |

THIS DOCUMENT IS THE PROPERTY OF HER BRITANNIC MAJESTY'S GOVERNMENT, and is issued for the information of such persons only as need to know its contents in the course of their official duties. Any person finding this document should hand it to a British forces unit or to a police station for its safe return to the MINISTRY OF DEFENCE (Dsy (Pol)), MAIN BUILDING, WHITEHALL, LONDON SW1A 2HB with particulars of how and where found. THE UNAUTHORIZED RETENTION OR DESTRUCTION OF THIS DOCUMENT MAY BE AN OFFENCE UNDER THE OFFICIAL SECRETS ACTS OF 1911-1989. (When released to persons outside Government service, this document is issued on a personal basis and the recipient to whom it may be entrusted in confidence, within the provision of the Official Secrets Acts 1911-1989, is personally responsible for its safe custody and for seeing that its contents are disclosed only to authorized persons).

**CARRIER, PERSONNEL, FULL TRACKED, FV432 MK 2 AND 2/1  
MODIFICATION INSTRUCTION NO. 1 (EMER TV E107/2 Mod Instr No 1)**

**SUBJECT: Drivers instrument panel**

**CANCELLATION**

**INTRODUCTION**

- 1 AESP 2350-T-251-811 Mod Instr No. 1, EMER TV E107 Mod Instr No.1 dated Jul 64 is hereby cancelled. The details of this modification have been incorporated into the build standard.

**ACTION**

- 2 Amend AESP 2350-T-251-811 Mod Instr No.1, EMER TV E107/2 modification index accordingly
- 3 File this Page 1/2 in place of Mod Instr No. 1 dated Jul 64, all pages of which are to be destroyed.

ELECTRICAL AND MECHANICAL

ENGINEERING REGULATIONS:

(By Command of the Defence Council)

*Atkins* Branch *Defects & Mods*  
~~RESTRICTED~~ Mr DAVIES. *Crosby*  
Attr. ....

Advance Copy for Information E 107/2 Mod Instr No 2

TRACKED VEHICLES

E 107/2 Mod Instr No 2

DEFECTS AND  
MODIFICATIONS BRANCH

- 6 JUL 1965

TECHNICAL GROUP  
R. E. M. E.

CARRIER, PERSONNEL, FULL TRACKED, MK 1, FV 432

TECHNICAL HANDBOOK - MODIFICATION INSTRUCTION

Cancellation

1. Issue 1 of this instruction referred to fitting a straight through exhaust pipe as a replacement of original silencer.
2. Subsequently a double skinned stainless steel silencer was introduced on later production vehicles, this silencer being secured by a single bolt fixing. The early pattern silencers, subject to premature failure, were secured by clamp supports welded to hull roof.
3. The information contained in Issue 1 has now been superseded by that contained in Tkd Veh E 107/2 Mod Instr No 18.
4. All copies of Issue 1, Pages 1-2 dated 20 Oct 64, are hereby cancelled and will be destroyed. Amend Mod Instr Index.  
Issue 2, 21 Jun 65

END

Distribution - Class 291. Code No 2

Page 1

CONDITIONS OF RELEASE

- |   |   |
|---|---|
| 1 This information is released by the UK Government for Defence purposes only.  | 3 This information may be disclosed only within the Defence Department of the recipient Government, except as otherwise authorized by Ministry of Defence (Army). |
| 2 This information must be afforded the same degree of protection as that afforded to information of an equivalent security marking originated by the recipient Government or as required by the recipient Government's security regulations. | 4 This information may be subject to privately owned rights.  |

THIS DOCUMENT IS THE PROPERTY OF HER BRITANNIC MAJESTY'S GOVERNMENT, and is issued for the information of such persons only as need to know its contents in the course of their official duties. Any person finding this document should hand it to a British forces unit or to a police station for its safe return to the MINISTRY OF DEFENCE (Dsy (Pol)), MAIN BUILDING, WHITEHALL, LONDON SW1A 2HB with particulars of how and where found. THE UNAUTHORIZED RETENTION OR DESTRUCTION OF THIS DOCUMENT MAY BE AN OFFENCE UNDER THE OFFICIAL SECRETS ACTS OF 1911-1989. (When released to persons outside Government service, this document is issued on a personal basis and the recipient to whom it may be entrusted in confidence, within the provision of the Official Secrets Acts 1911-1989, is personally responsible for its safe custody and for seeing that its contents are disclosed only to authorized persons).

**CARRIER, PERSONNEL, FULL TRACKED, FV 432 MK 2 AND 2/1**

**MODIFICATION INSTRUCTION NO. 1**

**SUBJECT: Alternator mounting**

**CANCELLATION**

**INTRODUCTION**

1 AESP 2350-T-251-811 Mod Instr No. 1, EMER E107/2 Mod Instr 3 is hereby cancelled. This modification is applicable to MK 1 vehicles only.

**ACTION**

- 2 Amend AESP 2350-T-251-811 Mod Instr 1, EMER E107/2 modification index accordingly.
- 3 File this Page 1/2 in place of Mod Instr No. 3 dated Sep 66, all pages of which are to be destroyed.

**CONDITIONS OF RELEASE**

- |   |   |   |   |
|---|---|---|---|
| 1 | This information is released by the UK Government for Defence purposes only.  | 3 | This information may be disclosed only within the Defence Department of the recipient Government, except as otherwise authorized by Ministry of Defence (Army). |
| 2 | This information must be afforded the same degree of protection as that afforded to information of an equivalent security marking originated by the recipient Government or as required by the recipient Government's security regulations. | 4 | This information may be subject to privately owned rights.  |

THIS DOCUMENT IS THE PROPERTY OF HER BRITANNIC MAJESTY'S GOVERNMENT, and is issued for the information of such persons only as need to know its contents in the course of their official duties. Any person finding this document should hand it to a British forces unit or to a police station for its safe return to the MINISTRY OF DEFENCE (Dsy (Pol)), MAIN BUILDING, WHITEHALL, LONDON SW1A 2HB with particulars of how and where found. THE UNAUTHORIZED RETENTION OR DESTRUCTION OF THIS DOCUMENT MAY BE AN OFFENCE UNDER THE OFFICIAL SECRETS ACTS OF 1911-1989. (When released to persons outside Government service, this document is issued on a personal basis and the recipient to whom it may be entrusted in confidence, within the provision of the Official Secrets Acts 1911-1989, is personally responsible for its safe custody and for seeing that its contents are disclosed only to authorized persons).

**CARRIER, PERSONNEL, FULL TRACKED, FV432 MK 2 AND 2/1  
MODIFICATION INSTRUCTION NO. 1 (EMER TV E107/2 Mod Instr No 4)**

**SUBJECT: Gearbox dipstick**

**CANCELLATION**

**INTRODUCTION**

- 1 AESP 2350-T-251-811 Mod Instr No. 1, EMER TV E107 Mod Instr No.4 dated Jan 65 is hereby cancelled. The details of this modification have been incorporated into the build standard.

**ACTION**

- 2 Amend AESP 2350-T-251-811 Mod Instr No.1, EMER TV E107/2 modification index accordingly
- 3 File this Page 1/2 in place of Mod Instr No. 4 dated Jan 65, all pages of which are to be destroyed.

CONDITIONS OF RELEASE

- |   |   |   |   |
|---|---|---|---|
| 1 | This information is released by the UK Government for Defence purposes only.  | 3 | This information may be disclosed only within the Defence Department of the recipient Government, except as otherwise authorized by Ministry of Defence (Army). |
| 2 | This information must be afforded the same degree of protection as that afforded to information of an equivalent security marking originated by the recipient Government or as required by the recipient Government's security regulations. | 4 | This information may be subject to privately owned rights.  |

THIS DOCUMENT IS THE PROPERTY OF HER BRITANNIC MAJESTY'S GOVERNMENT, and is issued for the information of such persons only as need to know its contents in the course of their official duties. Any person finding this document should hand it to a British forces unit or to a police station for its safe return to the MINISTRY OF DEFENCE (Dsy (Pol)), MAIN BUILDING, WHITEHALL, LONDON SW1A 2HB with particulars of how and where found. THE UNAUTHORIZED RETENTION OR DESTRUCTION OF THIS DOCUMENT MAY BE AN OFFENCE UNDER THE OFFICIAL SECRETS ACTS OF 1911-1989. (When released to persons outside Government service, this document is issued on a personal basis and the recipient to whom it may be entrusted in confidence, within the provision of the Official Secrets Acts 1911-1989, is personally responsible for its safe custody and for seeing that its contents are disclosed only to authorized persons).

**CARRIER, PERSONNEL, FULL TRACKED, FV 432 MK 2 AND 2/1**

**MODIFICATION INSTRUCTION NO. 1**

---

**SUBJECT: Hull roof plate handle**

**CANCELLATION**

**INTRODUCTION**

1 AESP 2350-T-251-811 Mod Instr No. 1, EMER E107/2 Mod Instr 5 is hereby cancelled. The details of this modification have been incorporated into the build standard. The seat referred to in this instruction has been superseded by a metric seat. The original design of drivers seat is to be replaced on failure with the new metric seat.

**ACTION**

- 2 Amend AESP 2350-T-251-811 Mod Instr 1, EMER E107/2 modification index accordingly.
- 3 File this Page 1/2 in place of Mod Instr No. 5 dated Sep 65, all pages of which are to be destroyed.

CONDITIONS OF RELEASE

- |   |   |   |   |
|---|---|---|---|
| 1 | This information is released by the UK Government for Defence purposes only.  | 3 | This information may be disclosed only within the Defence Department of the recipient Government, except as otherwise authorized by Ministry of Defence (Army). |
| 2 | This information must be afforded the same degree of protection as that afforded to information of an equivalent security marking originated by the recipient Government or as required by the recipient Government's security regulations. | 4 | This information may be subject to privately owned rights.  |

THIS DOCUMENT IS THE PROPERTY OF HER BRITANNIC MAJESTY'S GOVERNMENT, and is issued for the information of such persons only as need to know its contents in the course of their official duties. Any person finding this document should hand it to a British forces unit or to a police station for its safe return to the MINISTRY OF DEFENCE (Dsy (Pol)), MAIN BUILDING, WHITEHALL, LONDON SW1A 2HB with particulars of how and where found. THE UNAUTHORIZED RETENTION OR DESTRUCTION OF THIS DOCUMENT MAY BE AN OFFENCE UNDER THE OFFICIAL SECRETS ACTS OF 1911-1989. (When released to persons outside Government service, this document is issued on a personal basis and the recipient to whom it may be entrusted in confidence, within the provision of the Official Secrets Acts 1911-1989, is personally responsible for its safe custody and for seeing that its contents are disclosed only to authorized persons).

**CARRIER, PERSONNEL, FULL TRACKED, FV 432 MK 2 AND 2/1**

**MODIFICATION INSTRUCTION NO. 1**

---

**SUBJECT: Fan drive**

**CANCELLATION**

**INTRODUCTION**

1 AESP 2350-T-251-811 Mod Instr No. 1, EMER E107/2 Mod Instr 6 is hereby cancelled. This modification is applicable to MK 1 vehicles only.

**ACTION**

- 2 Amend AESP 2350-T-251-811 Mod Instr 1, EMER E107/2 modification index accordingly.
- 3 File this Page 1/2 in place of Mod Instr No. 6 dated Jan 65, all pages of which are to be destroyed.

CONDITIONS OF RELEASE

- |   |   |   |   |
|---|---|---|---|
| 1 | This information is released by the UK Government for Defence purposes only.  | 3 | This information may be disclosed only within the Defence Department of the recipient Government, except as otherwise authorized by Ministry of Defence (Army). |
| 2 | This information must be afforded the same degree of protection as that afforded to information of an equivalent security marking originated by the recipient Government or as required by the recipient Government's security regulations. | 4 | This information may be subject to privately owned rights.  |

THIS DOCUMENT IS THE PROPERTY OF HER BRITANNIC MAJESTY'S GOVERNMENT, and is issued for the information of such persons only as need to know its contents in the course of their official duties. Any person finding this document should hand it to a British forces unit or to a police station for its safe return to the MINISTRY OF DEFENCE (Dsy (Pol)), MAIN BUILDING, WHITEHALL, LONDON SW1A 2HB with particulars of how and where found. THE UNAUTHORIZED RETENTION OR DESTRUCTION OF THIS DOCUMENT MAY BE AN OFFENCE UNDER THE OFFICIAL SECRETS ACTS OF 1911-1989. (When released to persons outside Government service, this document is issued on a personal basis and the recipient to whom it may be entrusted in confidence, within the provision of the Official Secrets Acts 1911-1989, is personally responsible for its safe custody and for seeing that its contents are disclosed only to authorized persons).

**CARRIER, PERSONNEL, FULL TRACKED, FV 432 MK 2 AND 2/1**

**MODIFICATION INSTRUCTION NO. 1**

---

**SUBJECT: Fan drive**

**CANCELLATION**

**INTRODUCTION**

1 AESP 2350-T-251-811 Mod Instr No. 1, EMER E107/2 Mod Instr 7 is hereby cancelled. This modification is applicable to MK 1 vehicles only.

**ACTION**

- 2 Amend AESP 2350-T-251-811 Mod Instr 1, EMER E107/2 modification index accordingly.
- 3 File this Page 1/2 in place of Mod Instr No. 7 dated Feb 65, all pages of which are to be destroyed.

CONDITIONS OF RELEASE

- |   |   |   |   |
|---|---|---|---|
| 1 | This information is released by the UK Government for Defence purposes only.  | 3 | This information may be disclosed only within the Defence Department of the recipient Government, except as otherwise authorized by Ministry of Defence (Army). |
| 2 | This information must be afforded the same degree of protection as that afforded to information of an equivalent security marking originated by the recipient Government or as required by the recipient Government's security regulations. | 4 | This information may be subject to privately owned rights.  |

THIS DOCUMENT IS THE PROPERTY OF HER BRITANNIC MAJESTY'S GOVERNMENT, and is issued for the information of such persons only as need to know its contents in the course of their official duties. Any person finding this document should hand it to a British forces unit or to a police station for its safe return to the MINISTRY OF DEFENCE (Dsy (Pol)), MAIN BUILDING, WHITEHALL, LONDON SW1A 2HB with particulars of how and where found. THE UNAUTHORIZED RETENTION OR DESTRUCTION OF THIS DOCUMENT MAY BE AN OFFENCE UNDER THE OFFICIAL SECRETS ACTS OF 1911-1989. (When released to persons outside Government service, this document is issued on a personal basis and the recipient to whom it may be entrusted in confidence, within the provision of the Official Secrets Acts 1911-1989, is personally responsible for its safe custody and for seeing that its contents are disclosed only to authorized persons).

**CARRIER, PERSONNEL, FULL TRACKED, FV 432 MK 2 AND 2/1**

**MODIFICATION INSTRUCTION NO. 1**

---

**SUBJECT: Hull roof plate handle**

**CANCELLATION**

**INTRODUCTION**

1 AESP 2350-T-251-811 Mod Instr No. 1, EMER E107/2 Mod Instr 8 is hereby cancelled. The details of this modification have been incorporated into the build standard.

**ACTION**

- 2 Amend AESP 2350-T-251-811 Mod Instr 1, EMER E107/2 modification index accordingly.
- 3 File this Page 1/2 in place of Mod Instr No. 8 dated Jun 66, all pages of which are to be destroyed.



CONDITIONS OF RELEASE	
1 This information is released by the UK Government to the recipient Government for Defence purposes only	3 This information may be disclosed only within the Defence Department of the recipient Government, except as otherwise authorised by Ministry of Defence (Army)
2 This information must be accorded the same degree of security protection as that accorded thereto by the UK Government	4 This information may be subject to privately owned rights

THIS DOCUMENT IS THE PROPERTY OF HER BRITANNIC MAJESTY'S GOVERNMENT, and is issued for the information of such persons only as need to know its contents in the course of their official duties. Any person finding this document should hand it into a British forces unit or to a police station for its safe return to the MINISTRY OF DEFENCE D.MO 5y LONDON SW1A 2HS with particulars of how and where found. THE UNAUTHORISED RETENTION OR DESTRUCTION OF THE DOCUMENT IS AN OFFENCE UNDER THE OFFICIAL SECRETS ACTS OF 1911-1939. (When released to persons outside Government service, this document is issued on a personal basis and the recipient to whom it is entrusted in confidence, within the provisions of the Official Secrets Acts 1911-1939, is personally responsible for its safe custody and for seeing that its contents are disclosed only to authorised persons).

CARRIER, PERSONNEL, FULL TRACKED, MK 1, 1/1, 2 AND 2/1 (FV 432)

TECHNICAL HANDBOOK - MODIFICATION INSTRUCTION

Note: This Issue 2, supersedes Issue 1 Pages 1-4 dated Jan 67 and Issue 1, Page 0 dated Jun 68.

SUBJECT: Jettison fuel tanks  
(MVEE Approval 21409)

CANCELLATION

1. This modification has been cancelled under the authority of 'A' Veh D&M Committee Approvals 31087/31088.
2. Salvage any useful items from modification kit and return to maintenance stock, scrap remaining items and dispose of through normal channels.
3. Remove all copies of Issue 1, Pages 0 and 1-6 of this instruction and destroy.
4. Against subject reference in modification instruction index add 'Cancelled'.

END

70811(213)  
Veh & Wpns Br REME ALM/43000

**CONDITIONS OF RELEASE**

- |   |   |   |   |
|---|---|---|---|
| 1 | This information is released by the UK Government for Defence purposes only.  | 3 | This information may be disclosed only within the Defence Department of the recipient Government, except as otherwise authorized by Ministry of Defence (Army). |
| 2 | This information must be afforded the same degree of protection as that afforded to information of an equivalent security marking originated by the recipient Government or as required by the recipient Government's security regulations. | 4 | This information may be subject to privately owned rights.  |

THIS DOCUMENT IS THE PROPERTY OF HER BRITANNIC MAJESTY'S GOVERNMENT, and is issued for the information of such persons only as need to know its contents in the course of their official duties. Any person finding this document should hand it to a British forces unit or to a police station for its safe return to the MINISTRY OF DEFENCE (Dsy (Pol)), MAIN BUILDING, WHITEHALL, LONDON SW1A 2HB with particulars of how and where found. THE UNAUTHORIZED RETENTION OR DESTRUCTION OF THIS DOCUMENT MAY BE AN OFFENCE UNDER THE OFFICIAL SECRETS ACTS OF 1911-1989. (When released to persons outside Government service, this document is issued on a personal basis and the recipient to whom it may be entrusted in confidence, within the provision of the Official Secrets Acts 1911-1989, is personally responsible for its safe custody and for seeing that its contents are disclosed only to authorized persons).

**CARRIER, PERSONNEL, FULL TRACKED, FV432 MK 2 AND 2/1  
MODIFICATION INSTRUCTION NO. 1 (EMER TV E107/2 Mod Instr No 10)**

**SUBJECT: Commanders periscope wiper**

**CANCELLATION**

**INTRODUCTION**

- 1 AESP 2350-T-251-811 Mod Instr No. 1, EMER TV E107 Mod Instr No.10 dated Nov 66 is hereby cancelled. The details of this modification have been incorporated into the build standard.

**ACTION**

- 2 Amend AESP 2350-T-251-811 Mod Instr No.1, EMER TV E107/2 modification index accordingly
- 3 File this Page 1/2 in place of Mod Instr No. 10 dated Nov 66, all pages of which are to be destroyed.

CONDITIONS OF RELEASE

- |   |   |   |   |
|---|---|---|---|
| 1 | This information is released by the UK Government for Defence purposes only.  | 3 | This information may be disclosed only within the Defence Department of the recipient Government, except as otherwise authorized by Ministry of Defence (Army). |
| 2 | This information must be afforded the same degree of protection as that afforded to information of an equivalent security marking originated by the recipient Government or as required by the recipient Government's security regulations. | 4 | This information may be subject to privately owned rights.  |

THIS DOCUMENT IS THE PROPERTY OF HER BRITANNIC MAJESTY'S GOVERNMENT, and is issued for the information of such persons only as need to know its contents in the course of their official duties. Any person finding this document should hand it to a British forces unit or to a police station for its safe return to the MINISTRY OF DEFENCE (Dsy (Pol)), MAIN BUILDING, WHITEHALL, LONDON SW1A 2HB with particulars of how and where found. THE UNAUTHORIZED RETENTION OR DESTRUCTION OF THIS DOCUMENT MAY BE AN OFFENCE UNDER THE OFFICIAL SECRETS ACTS OF 1911-1989. (When released to persons outside Government service, this document is issued on a personal basis and the recipient to whom it may be entrusted in confidence, within the provision of the Official Secrets Acts 1911-1989, is personally responsible for its safe custody and for seeing that its contents are disclosed only to authorized persons).

**CARRIER, PERSONNEL, FULL TRACKED, FV 432 MK 2 AND 2/1**

**MODIFICATION INSTRUCTION NO. 1**

---

**SUBJECT: Drivers hood windscreen**

**CANCELLATION**

**INTRODUCTION**

1 AESP 2350-T-251-811 Mod Instr No. 1, EMER E107/2 Mod Instr 11 is hereby cancelled. This modification was applicable to equipment that has been declared obsolete, and is therefore no longer required.

**ACTION**

- 2 Amend AESP 2350-T-251-811 Mod Instr 1, EMER E107/2 modification index accordingly.
- 3 File this Page 1/2 in place of Mod Instr No. 11 dated Jan 65, all pages of which are to be destroyed.

CONDITIONS OF RELEASE

- |   |   |   |   |
|---|---|---|---|
| 1 | This information is released by the UK Government for Defence purposes only.  | 3 | This information may be disclosed only within the Defence Department of the recipient Government, except as otherwise authorized by Ministry of Defence (Army). |
| 2 | This information must be afforded the same degree of protection as that afforded to information of an equivalent security marking originated by the recipient Government or as required by the recipient Government's security regulations. | 4 | This information may be subject to privately owned rights.  |

THIS DOCUMENT IS THE PROPERTY OF HER BRITANNIC MAJESTY'S GOVERNMENT, and is issued for the information of such persons only as need to know its contents in the course of their official duties. Any person finding this document should hand it to a British forces unit or to a police station for its safe return to the MINISTRY OF DEFENCE (Dsy (Pol)), MAIN BUILDING, WHITEHALL, LONDON SW1A 2HB with particulars of how and where found. THE UNAUTHORIZED RETENTION OR DESTRUCTION OF THIS DOCUMENT MAY BE AN OFFENCE UNDER THE OFFICIAL SECRETS ACTS OF 1911-1989. (When released to persons outside Government service, this document is issued on a personal basis and the recipient to whom it may be entrusted in confidence, within the provision of the Official Secrets Acts 1911-1989, is personally responsible for its safe custody and for seeing that its contents are disclosed only to authorized persons).

**CARRIER, PERSONNEL, FULL TRACKED, FV 432 MK 2 AND 2/1**

**MODIFICATION INSTRUCTION NO. 1**

---

**SUBJECT: Fuel system**

**CANCELLATION**

**INTRODUCTION**

1 AESP 2350-T-251-811 Mod Instr No. 1, EMER E107/2 Mod Instr 12 is hereby cancelled. The details of this modification have been incorporated into the build standard.

**ACTION**

- 2 Amend AESP 2350-T-251-811 Mod Instr 1, EMER E107/2 modification index accordingly.
- 3 File this Page 1/2 in place of Mod Instr No. 12 dated Oct 65, all pages of which are to be destroyed.

CONDITIONS OF RELEASE

- |   |   |   |   |
|---|---|---|---|
| 1 | This information is released by the UK Government for Defence purposes only.  | 3 | This information may be disclosed only within the Defence Department of the recipient Government, except as otherwise authorized by Ministry of Defence (Army). |
| 2 | This information must be afforded the same degree of protection as that afforded to information of an equivalent security marking originated by the recipient Government or as required by the recipient Government's security regulations. | 4 | This information may be subject to privately owned rights.  |

THIS DOCUMENT IS THE PROPERTY OF HER BRITANNIC MAJESTY'S GOVERNMENT, and is issued for the information of such persons only as need to know its contents in the course of their official duties. Any person finding this document should hand it to a British forces unit or to a police station for its safe return to the MINISTRY OF DEFENCE (Dsy (Pol)), MAIN BUILDING, WHITEHALL, LONDON SW1A 2HB with particulars of how and where found. THE UNAUTHORIZED RETENTION OR DESTRUCTION OF THIS DOCUMENT MAY BE AN OFFENCE UNDER THE OFFICIAL SECRETS ACTS OF 1911-1989. (When released to persons outside Government service, this document is issued on a personal basis and the recipient to whom it may be entrusted in confidence, within the provision of the Official Secrets Acts 1911-1989, is personally responsible for its safe custody and for seeing that its contents are disclosed only to authorized persons).

**CARRIER, PERSONNEL, FULL TRACKED, FV 432 MK 2 AND 2/1**

**MODIFICATION INSTRUCTION NO. 1**

---

**SUBJECT: Oil can stowage**

**CANCELLATION**

**INTRODUCTION**

1 AESP 2350-T-251-811 Mod Instr No. 1, EMER E107/2 Mod Instr 13 is hereby cancelled. The details of this modification have been incorporated into the build standard.

**ACTION**

- 2 Amend AESP 2350-T-251-811 Mod Instr 1, EMER E107/2 modification index accordingly.
- 3 File this Page 1/2 in place of Mod Instr No. 13 dated Apr 65, all pages of which are to be destroyed.

CONDITIONS OF RELEASE

- |   |   |   |   |
|---|---|---|---|
| 1 | This information is released by the UK Government for Defence purposes only.  | 3 | This information may be disclosed only within the Defence Department of the recipient Government, except as otherwise authorized by Ministry of Defence (Army). |
| 2 | This information must be afforded the same degree of protection as that afforded to information of an equivalent security marking originated by the recipient Government or as required by the recipient Government's security regulations. | 4 | This information may be subject to privately owned rights.  |

THIS DOCUMENT IS THE PROPERTY OF HER BRITANNIC MAJESTY'S GOVERNMENT, and is issued for the information of such persons only as need to know its contents in the course of their official duties. Any person finding this document should hand it to a British forces unit or to a police station for its safe return to the MINISTRY OF DEFENCE (Dsy (Pol)), MAIN BUILDING, WHITEHALL, LONDON SW1A 2HB with particulars of how and where found. THE UNAUTHORIZED RETENTION OR DESTRUCTION OF THIS DOCUMENT MAY BE AN OFFENCE UNDER THE OFFICIAL SECRETS ACTS OF 1911-1989. (When released to persons outside Government service, this document is issued on a personal basis and the recipient to whom it may be entrusted in confidence, within the provision of the Official Secrets Acts 1911-1989, is personally responsible for its safe custody and for seeing that its contents are disclosed only to authorized persons).

**CARRIER, PERSONNEL, FULL TRACKED, FV 432 MK 2 AND 2/1**

**MODIFICATION INSTRUCTION NO. 1**

**SUBJECT: Accelerator pedal stop**

**CANCELLATION**

**INTRODUCTION**

1 AESP 2350-T-251-811 Mod Instr No. 1, EMER E107/2 Mod Instr 14 is hereby cancelled. The details of this modification have been incorporated into the build standard.

**ACTION**

- 2 Amend AESP 2350-T-251-811 Mod Instr 1, EMER E107/2 modification index accordingly.
- 3 File this Page 1/2 in place of Mod Instr No. 14 dated Apr 65, all pages of which are to be destroyed.

CONDITIONS OF RELEASE

- |   |   |   |   |
|---|---|---|---|
| 1 | This information is released by the UK Government for Defence purposes only.  | 3 | This information may be disclosed only within the Defence Department of the recipient Government, except as otherwise authorized by Ministry of Defence (Army). |
| 2 | This information must be afforded the same degree of protection as that afforded to information of an equivalent security marking originated by the recipient Government or as required by the recipient Government's security regulations. | 4 | This information may be subject to privately owned rights.  |

THIS DOCUMENT IS THE PROPERTY OF HER BRITANNIC MAJESTY'S GOVERNMENT, and is issued for the information of such persons only as need to know its contents in the course of their official duties. Any person finding this document should hand it to a British forces unit or to a police station for its safe return to the MINISTRY OF DEFENCE (Dsy (Pol)), MAIN BUILDING, WHITEHALL, LONDON SW1A 2HB with particulars of how and where found. THE UNAUTHORIZED RETENTION OR DESTRUCTION OF THIS DOCUMENT MAY BE AN OFFENCE UNDER THE OFFICIAL SECRETS ACTS OF 1911-1989. (When released to persons outside Government service, this document is issued on a personal basis and the recipient to whom it may be entrusted in confidence, within the provision of the Official Secrets Acts 1911-1989, is personally responsible for its safe custody and for seeing that its contents are disclosed only to authorized persons).

**CARRIER, PERSONNEL, FULL TRACKED, FV 432 MK 2 AND 2/1**

**MODIFICATION INSTRUCTION NO. 1**

---

**SUBJECT: Socket protection caps**

**CANCELLATION**

**INTRODUCTION**

1 AESP 2350-T-251-811 Mod Instr No. 1, EMER E107/2 Mod Instr 15 is hereby cancelled. The details of this modification have been incorporated into the build standard.

**ACTION**

- 2 Amend AESP 2350-T-251-811 Mod Instr 1, EMER E107/2 modification index accordingly.
- 3 File this Page 1/2 in place of Mod Instr No. 15 dated May 65, all pages of which are to be destroyed.

CONDITIONS OF RELEASE

- |   |   |   |   |
|---|---|---|---|
| 1 | This information is released by the UK Government for Defence purposes only.  | 3 | This information may be disclosed only within the Defence Department of the recipient Government, except as otherwise authorized by Ministry of Defence (Army). |
| 2 | This information must be afforded the same degree of protection as that afforded to information of an equivalent security marking originated by the recipient Government or as required by the recipient Government's security regulations. | 4 | This information may be subject to privately owned rights.  |

THIS DOCUMENT IS THE PROPERTY OF HER BRITANNIC MAJESTY'S GOVERNMENT, and is issued for the information of such persons only as need to know its contents in the course of their official duties. Any person finding this document should hand it to a British forces unit or to a police station for its safe return to the MINISTRY OF DEFENCE (Dsy (Pol)), MAIN BUILDING, WHITEHALL, LONDON SW1A 2HB with particulars of how and where found. THE UNAUTHORIZED RETENTION OR DESTRUCTION OF THIS DOCUMENT MAY BE AN OFFENCE UNDER THE OFFICIAL SECRETS ACTS OF 1911-1989. (When released to persons outside Government service, this document is issued on a personal basis and the recipient to whom it may be entrusted in confidence, within the provision of the Official Secrets Acts 1911-1989, is personally responsible for its safe custody and for seeing that its contents are disclosed only to authorized persons).

**CARRIER, PERSONNEL, FULL TRACKED, FV 432 MK 2 AND 2/1**

**MODIFICATION INSTRUCTION NO. 1**

---

**SUBJECT: Hull floor plate**

**CANCELLATION**

**INTRODUCTION**

1 AESP 2350-T-251-811 Mod Instr No. 1, EMER E107/2 Mod Instr 16 is hereby cancelled. The details of this modification have been incorporated into the build standard.

**ACTION**

- 2 Amend AESP 2350-T-251-811 Mod Instr 1, EMER E107/2 modification index accordingly .
- 3 File this Page 1/2 in place of Mod Instr No. 16 dated Mar 65, all pages of which are to be destroyed.



**CONDITIONS OF RELEASE**

- |   |   |   |   |
|---|---|---|---|
| 1 | This information is released by the UK Government for Defence purposes only.  | 3 | This information may be disclosed only within the Defence Department of the recipient Government, except as otherwise authorized by Ministry of Defence (Army). |
| 2 | This information must be afforded the same degree of protection as that afforded to information of an equivalent security marking originated by the recipient Government or as required by the recipient Government's security regulations. | 4 | This information may be subject to privately owned rights.  |

THIS DOCUMENT IS THE PROPERTY OF HER BRITANNIC MAJESTY'S GOVERNMENT, and is issued for the information of such persons only as need to know its contents in the course of their official duties. Any person finding this document should hand it to a British forces unit or to a police station for its safe return to the MINISTRY OF DEFENCE (Dsy (Pol)), MAIN BUILDING, WHITEHALL, LONDON SW1A 2HB with particulars of how and where found. THE UNAUTHORIZED RETENTION OR DESTRUCTION OF THIS DOCUMENT MAY BE AN OFFENCE UNDER THE OFFICIAL SECRETS ACTS OF 1911-1989. (When released to persons outside Government service, this document is issued on a personal basis and the recipient to whom it may be entrusted in confidence, within the provision of the Official Secrets Acts 1911-1989, is personally responsible for its safe custody and for seeing that its contents are disclosed only to authorized persons).

**CARRIER, PERSONNEL, FULL TRACKED, FV 432 MK 2 AND 2/1**

**MODIFICATION INSTRUCTION NO. 1**

---

**SUBJECT: Track pad deflectors**

**CANCELLATION**

**INTRODUCTION**

1 AESP 2350-T-251-811 Mod Instr No. 1, EMER E107/2 Mod Instr 17 is hereby cancelled. This modification has been superseded by AESP 2350-T-251-811 Mod Instr No. 1, EMER E107/2 Mod Instr 69.

**ACTION**

- 2 Amend AESP 2350-T-251-811 Mod Instr 1, EMER E107/2 modification index accordingly.
- 3 File this Page 1/2 in place of Mod Instr No. 17 dated May 67, all pages of which are to be destroyed.

CONDITIONS OF RELEASE	
1 This information is released by the UK Government to the recipient Government for Defence purposes only	3 This information may be disclosed only within the Defence Department of the recipient Government, except as otherwise authorised by Ministry of Defence (Army)
2 This information must be accorded the same degree of security protection as that accorded thereto by the UK Government	4 This information may be subject to privately owned rights

THIS DOCUMENT IS THE PROPERTY OF HER BRITANNIC MAJESTY'S GOVERNMENT, and is issued for the information of such persons only as need to know its contents in the course of their official duties. Any person finding this document should hand it into a British forces unit or to a police station for its safe return to the MINISTRY OF DEFENCE D.MOD 5y LONDON SW1A 2HB with particulars of how and where found. THE UNAUTHORISED RETENTION OR DESTRUCTION OF THE DOCUMENT IS AN OFFENCE UNDER THE OFFICIAL SECRETS ACTS OF 1911-1939. (When released to persons outside Government service, this document is issued on a personal basis and the recipient to whom it is entrusted in confidence, within the provisions of the Official Secrets Acts 1911-1939, is personally responsible for its safe custody and for seeing that its contents are disclosed only to authorised persons).

CARRIER, PERSONNEL, FULL TRACKED, MK 1, 1/1, 2 AND 2/1 (FV 432)

TECHNICAL HANDBOOK - MODIFICATION INSTRUCTION

Note: This Issue 2, supersedes Issue 1, Pages 1-7 dated Jun 65, Pages 0-01 dated Sep 65 and Pages 02-03 dated Dec 65.

SUBJECT: Exhaust system  
(MVEE Approval 21464)

CANCELLATION

1. This modification has been cancelled under the authority of 'A' Veh D & M Committee Approvals 31017/31042.
2. Salvage any useful items from the modification kit and return to maintenance stock. Scrap remaining items and dispose of through normal channels.
3. Remove all copies of Issue 1, Pages 0-3 and 1-7 of this instruction and destroy.
4. Against subject reference in modification instruction index add 'Cancelled'.

END

70811 (214)  
Vehs & Wpns Br REME AIM/43000

CONDITIONS OF RELEASE

- |   |   |   |   |
|---|---|---|---|
| 1 | This information is released by the UK Government for Defence purposes only.  | 3 | This information may be disclosed only within the Defence Department of the recipient Government, except as otherwise authorized by Ministry of Defence (Army). |
| 2 | This information must be afforded the same degree of protection as that afforded to information of an equivalent security marking originated by the recipient Government or as required by the recipient Government's security regulations. | 4 | This information may be subject to privately owned rights.  |

THIS DOCUMENT IS THE PROPERTY OF HER BRITANNIC MAJESTY'S GOVERNMENT, and is issued for the information of such persons only as need to know its contents in the course of their official duties. Any person finding this document should hand it to a British forces unit or to a police station for its safe return to the MINISTRY OF DEFENCE (Dsy (Pol)), MAIN BUILDING, WHITEHALL, LONDON SW1A 2HB with particulars of how and where found. THE UNAUTHORIZED RETENTION OR DESTRUCTION OF THIS DOCUMENT MAY BE AN OFFENCE UNDER THE OFFICIAL SECRETS ACTS OF 1911-1989. (When released to persons outside Government service, this document is issued on a personal basis and the recipient to whom it may be entrusted in confidence, within the provision of the Official Secrets Acts 1911-1989, is personally responsible for its safe custody and for seeing that its contents are disclosed only to authorized persons).

**CARRIER, PERSONNEL, FULL TRACKED, FV 432 MK 2 AND 2/1**

**MODIFICATION INSTRUCTION NO. 1**

---

**SUBJECT: Air conditioning equipment**

**CANCELLATION**

**INTRODUCTION**

1 AESP 2350-T-251-811 Mod Instr No. 1, EMER E107/2 Mod Instr 19 is hereby cancelled. The details of this modification have been incorporated into the build standard.

**ACTION**

- 2 Amend AESP 2350-T-251-811 Mod Instr 1, EMER E107/2 modification index accordingly.
- 3 File this Page 1/2 in place of Mod Instr No. 19 dated Jul 65, all pages of which are to be destroyed.

**CONDITIONS OF RELEASE**

- |   |   |   |   |
|---|---|---|---|
| 1 | This information is released by the UK Government for Defence purposes only.  | 3 | This information may be disclosed only within the Defence Department of the recipient Government, except as otherwise authorized by Ministry of Defence (Army). |
| 2 | This information must be afforded the same degree of protection as that afforded to information of an equivalent security marking originated by the recipient Government or as required by the recipient Government's security regulations. | 4 | This information may be subject to privately owned rights.  |

THIS DOCUMENT IS THE PROPERTY OF HER BRITANNIC MAJESTY'S GOVERNMENT, and is issued for the information of such persons only as need to know its contents in the course of their official duties. Any person finding this document should hand it to a British forces unit or to a police station for its safe return to the MINISTRY OF DEFENCE (Dsy (Pol)), MAIN BUILDING, WHITEHALL, LONDON SW1A 2HB with particulars of how and where found. THE UNAUTHORIZED RETENTION OR DESTRUCTION OF THIS DOCUMENT MAY BE AN OFFENCE UNDER THE OFFICIAL SECRETS ACTS OF 1911-1989. (When released to persons outside Government service, this document is issued on a personal basis and the recipient to whom it may be entrusted in confidence, within the provision of the Official Secrets Acts 1911-1989, is personally responsible for its safe custody and for seeing that its contents are disclosed only to authorized persons).

**CARRIER, PERSONNEL, FULL TRACKED, FV 432 MK 2 AND 2/1**

**MODIFICATION INSTRUCTION NO. 1**

---

**SUBJECT: Steering levers**

**CANCELLATION**

**INTRODUCTION**

1 AESP 2350-T-251-811 Mod Instr No. 1, EMER E107/2 Mod Instr 20 is hereby cancelled. The details of this modification have been incorporated into the build standard.

**ACTION**

- 2 Amend AESP 2350-T-251-811 Mod Instr 1, EMER E107/2 modification index accordingly.
- 3 File this Page 1/2 in place of Mod Instr No. 20 dated Sep 65, all pages of which are to be destroyed.

CONDITIONS OF RELEASE

- |   |   |   |   |
|---|---|---|---|
| 1 | This information is released by the UK Government for Defence purposes only.  | 3 | This information may be disclosed only within the Defence Department of the recipient Government, except as otherwise authorized by Ministry of Defence (Army). |
| 2 | This information must be afforded the same degree of protection as that afforded to information of an equivalent security marking originated by the recipient Government or as required by the recipient Government's security regulations. | 4 | This information may be subject to privately owned rights.  |

THIS DOCUMENT IS THE PROPERTY OF HER BRITANNIC MAJESTY'S GOVERNMENT, and is issued for the information of such persons only as need to know its contents in the course of their official duties. Any person finding this document should hand it to a British forces unit or to a police station for its safe return to the MINISTRY OF DEFENCE (Dsy (Pol)), MAIN BUILDING, WHITEHALL, LONDON SW1A 2HB with particulars of how and where found. THE UNAUTHORIZED RETENTION OR DESTRUCTION OF THIS DOCUMENT MAY BE AN OFFENCE UNDER THE OFFICIAL SECRETS ACTS OF 1911-1989. (When released to persons outside Government service, this document is issued on a personal basis and the recipient to whom it may be entrusted in confidence, within the provision of the Official Secrets Acts 1911-1989, is personally responsible for its safe custody and for seeing that its contents are disclosed only to authorized persons).

**CARRIER, PERSONNEL, FULL TRACKED, FV 432 MK 2 AND 2/1**

**MODIFICATION INSTRUCTION NO. 1**

---

**SUBJECT: Navigation aid**

**CANCELLATION**

**INTRODUCTION**

1 AESP 2350-T-251-811 Mod Instr No. 1, EMER E107/2 Mod Instr 21 is hereby cancelled. The details of this modification have been incorporated into the build standard.

**ACTION**

- 2 Amend AESP 2350-T-251-811 Mod Instr 1, EMER E107/2 modification index accordingly.
- 3 File this Page 1/2 in place of Mod Instr No. 21 dated Sep 65, all pages of which are to be destroyed.

**CONDITIONS OF RELEASE**

- |   |   |   |   |
|---|---|---|---|
| 1 | This information is released by the UK Government for Defence purposes only.  | 3 | This information may be disclosed only within the Defence Department of the recipient Government, except as otherwise authorized by Ministry of Defence (Army). |
| 2 | This information must be afforded the same degree of protection as that afforded to information of an equivalent security marking originated by the recipient Government or as required by the recipient Government's security regulations. | 4 | This information may be subject to privately owned rights.  |

THIS DOCUMENT IS THE PROPERTY OF HER BRITANNIC MAJESTY'S GOVERNMENT, and is issued for the information of such persons only as need to know its contents in the course of their official duties. Any person finding this document should hand it to a British forces unit or to a police station for its safe return to the MINISTRY OF DEFENCE (Dsy (Pol)), MAIN BUILDING, WHITEHALL, LONDON SW1A 2HB with particulars of how and where found. THE UNAUTHORIZED RETENTION OR DESTRUCTION OF THIS DOCUMENT MAY BE AN OFFENCE UNDER THE OFFICIAL SECRETS ACTS OF 1911-1989. (When released to persons outside Government service, this document is issued on a personal basis and the recipient to whom it may be entrusted in confidence, within the provision of the Official Secrets Acts 1911-1989, is personally responsible for its safe custody and for seeing that its contents are disclosed only to authorized persons).

**CARRIER, PERSONNEL, FULL TRACKED, FV432 MK 2 AND 2/1  
MODIFICATION INSTRUCTION NO. 1 (EMER TV E107/2 Mod Instr No 22)**

**SUBJECT: Alternator, No.1 MK.1**

**CANCELLATION**

**INTRODUCTION**

- 1 AESP 2350-T-251-811 Mod Instr No. 1, EMER TV E107 Mod Instr No.22 dated Apr 66 is hereby cancelled. The details of this modification have been incorporated into the build standard.

**ACTION**

- 2 Amend AESP 2350-T-251-811 Mod Instr No.1, EMER TV E107/2 modification index accordingly
- 3 File this Page 1/2 in place of Mod Instr No. 22 dated Apr 66, all pages of which are to be destroyed.

CONDITIONS OF RELEASE

- |   |   |
|---|---|
| 1 This information is released by the UK Government for Defence purposes only.  | 3 This information may be disclosed only within the Defence Department of the recipient Government, except as otherwise authorized by Ministry of Defence (Army). |
| 2 This information must be afforded the same degree of protection as that afforded to information of an equivalent security marking originated by the recipient Government or as required by the recipient Government's security regulations. | 4 This information may be subject to privately owned rights.  |

THIS DOCUMENT IS THE PROPERTY OF HER BRITANNIC MAJESTY'S GOVERNMENT, and is issued for the information of such persons only as need to know its contents in the course of their official duties. Any person finding this document should hand it to a British forces unit or to a police station for its safe return to the MINISTRY OF DEFENCE (Dsy (Pol)), MAIN BUILDING, WHITEHALL, LONDON SW1A 2HB with particulars of how and where found. THE UNAUTHORIZED RETENTION OR DESTRUCTION OF THIS DOCUMENT MAY BE AN OFFENCE UNDER THE OFFICIAL SECRETS ACTS OF 1911-1989. (When released to persons outside Government service, this document is issued on a personal basis and the recipient to whom it may be entrusted in confidence, within the provision of the Official Secrets Acts 1911-1989, is personally responsible for its safe custody and for seeing that its contents are disclosed only to authorized persons).

**CARRIER, PERSONNEL, FULL TRACKED, FV 432 MK 2 AND 2/1**

**MODIFICATION INSTRUCTION NO. 1**

---

**SUBJECT: Drivers fire extinguisher controls**

**CANCELLATION**

**INTRODUCTION**

1 AESP 2350-T-251-811 Mod Instr No. 1, EMER E107/2 Mod Instr 23 is hereby cancelled. The details of this modification have been incorporated into the build standard.

**ACTION**

- 2 Amend AESP 2350-T-251-811 Mod Instr 1, EMER E107/2 modification index accordingly.
- 3 File this Page 1/2 in place of Mod Instr No. 23 dated Mar 66, all pages of which are to be destroyed.

CONDITIONS OF RELEASE	
1 This information is released by the UK Government to the recipient Government for Defence purposes only	3 This information may be disclosed only within the Defence Department of the recipient Government, except as otherwise authorised by Ministry of Defence (Army)
2 This information must be accorded the same degree of security protection as that accorded thereto by the UK Government	4 This information may be subject to privately owned rights

THIS DOCUMENT IS THE PROPERTY OF HER BRITANNIC MAJESTY'S GOVERNMENT, and is issued for the information of such persons only as need to know its contents in the course of their official duties. Any person finding this document should hand it into a British forces unit or to a police station for its safe return to the MINISTRY OF DEFENCE O.MOD 5y LONDON SW1A 2HB with particulars of how and where found. THE UNAUTHORISED RETENTION OR DESTRUCTION OF THE DOCUMENT IS AN OFFENCE UNDER THE OFFICIAL SECRETS ACTS OF 1911-1939. (When released to persons outside Government service, this document is issued on a personal basis and the recipient to whom it is entrusted in confidence, within the provisions of the Official Secrets Acts 1911-1939, is personally responsible for its safe custody and for seeing that its contents are disclosed only to authorized persons).

CARRIER, PERSONNEL, FULL TRACKED, MK 1, 1/1, 2 AND 2/1 (FV 432)

TECHNICAL HANDBOOK - MODIFICATION INSTRUCTION

Note: This Issue 2, supersedes Issue 1, Pages 1-3 dated Mar 66.

SUBJECT: Jettison fuel tanks  
(MVVEE Approval 21431)

CANCELLATION

1. This modification instruction has been cancelled under the authority of 'A' Veh D & M Committee Approvals 31087/31088.
2. Salvage any useful items from modification kit and return to maintenance stock. Scrap remaining items and dispose of through normal channels.
3. Remove all copies of Issue 1. Pages 1-3 of this instruction and destroy.
4. Against subject reference in modification instruction index add 'Cancelled'.

END



**CONDITIONS OF RELEASE**

- |   |   |   |   |
|---|---|---|---|
| 1 | This information is released by the UK Government for Defence purposes only.  | 3 | This information may be disclosed only within the Defence Department of the recipient Government, except as otherwise authorized by Ministry of Defence (Army). |
| 2 | This information must be afforded the same degree of protection as that afforded to information of an equivalent security marking originated by the recipient Government or as required by the recipient Government's security regulations. | 4 | This information may be subject to privately owned rights.  |

THIS DOCUMENT IS THE PROPERTY OF HER BRITANNIC MAJESTY'S GOVERNMENT, and is issued for the information of such persons only as need to know its contents in the course of their official duties. Any person finding this document should hand it to a British forces unit or to a police station for its safe return to the MINISTRY OF DEFENCE (Dsy (Pol)), MAIN BUILDING, WHITEHALL, LONDON SW1A 2HB with particulars of how and where found. THE UNAUTHORIZED RETENTION OR DESTRUCTION OF THIS DOCUMENT MAY BE AN OFFENCE UNDER THE OFFICIAL SECRETS ACTS OF 1911-1989. (When released to persons outside Government service, this document is issued on a personal basis and the recipient to whom it may be entrusted in confidence, within the provision of the Official Secrets Acts 1911-1989, is personally responsible for its safe custody and for seeing that its contents are disclosed only to authorized persons).

**CARRIER, PERSONNEL, FULL TRACKED, FV432 MK 2 AND 2/1  
MODIFICATION INSTRUCTION NO. 1 (EMER TV E107/2 Mod Instr No 25)**

**SUBJECT: Sprocket ring bolts**

**CANCELLATION**

**INTRODUCTION**

- 1 AESP 2350-T-251-811 Mod Instr No. 1, EMER TV E107 Mod Instr No.25 dated Mar 66 is hereby cancelled. The details of this modification have been incorporated into the build standard.

**ACTION**

- 2 Amend AESP 2350-T-251-811 Mod Instr No.1, EMER TV E107/2 modification index accordingly
- 3 File this Page 1/2 in place of Mod Instr No. 25 dated Mar 66, all pages of which are to be destroyed.

CONDITIONS OF RELEASE

- |   |   |   |   |
|---|---|---|---|
| 1 | This information is released by the UK Government for Defence purposes only.  | 3 | This information may be disclosed only within the Defence Department of the recipient Government, except as otherwise authorized by Ministry of Defence (Army). |
| 2 | This information must be afforded the same degree of protection as that afforded to information of an equivalent security marking originated by the recipient Government or as required by the recipient Government's security regulations. | 4 | This information may be subject to privately owned rights.  |

THIS DOCUMENT IS THE PROPERTY OF HER BRITANNIC MAJESTY'S GOVERNMENT, and is issued for the information of such persons only as need to know its contents in the course of their official duties. Any person finding this document should hand it to a British forces unit or to a police station for its safe return to the MINISTRY OF DEFENCE (Dsy (Pol)), MAIN BUILDING, WHITEHALL, LONDON SW1A 2HB with particulars of how and where found. THE UNAUTHORIZED RETENTION OR DESTRUCTION OF THIS DOCUMENT MAY BE AN OFFENCE UNDER THE OFFICIAL SECRETS ACTS OF 1911-1989. (When released to persons outside Government service, this document is issued on a personal basis and the recipient to whom it may be entrusted in confidence, within the provision of the Official Secrets Acts 1911-1989, is personally responsible for its safe custody and for seeing that its contents are disclosed only to authorized persons).

**CARRIER, PERSONNEL, FULL TRACKED, FV 432 MK 2 AND 2/1**

**MODIFICATION INSTRUCTION NO. 1**

**SUBJECT: Hull floor**

**CANCELLATION**

**INTRODUCTION**

1 AESP 2350-T-251-811 Mod Instr No. 1, EMER E107/2 Mod Instr 26 is hereby cancelled. The details of this modification have been incorporated into the build standard.

**ACTION**

- 2 Amend AESP 2350-T-251-811 Mod Instr 1, EMER E107/2 modification index accordingly.
- 3 File this Page 1/2 in place of Mod Instr No. 26 dated Jul 66, all pages of which are to be destroyed.

**CONDITIONS OF RELEASE**

- |   |   |   |   |
|---|---|---|---|
| 1 | This information is released by the UK Government for Defence purposes only.  | 3 | This information may be disclosed only within the Defence Department of the recipient Government, except as otherwise authorized by Ministry of Defence (Army). |
| 2 | This information must be afforded the same degree of protection as that afforded to information of an equivalent security marking originated by the recipient Government or as required by the recipient Government's security regulations. | 4 | This information may be subject to privately owned rights.  |

THIS DOCUMENT IS THE PROPERTY OF HER BRITANNIC MAJESTY'S GOVERNMENT, and is issued for the information of such persons only as need to know its contents in the course of their official duties. Any person finding this document should hand it to a British forces unit or to a police station for its safe return to the MINISTRY OF DEFENCE (Dsy (Pol)), MAIN BUILDING, WHITEHALL, LONDON SW1A 2HB with particulars of how and where found. THE UNAUTHORIZED RETENTION OR DESTRUCTION OF THIS DOCUMENT MAY BE AN OFFENCE UNDER THE OFFICIAL SECRETS ACTS OF 1911-1989. (When released to persons outside Government service, this document is issued on a personal basis and the recipient to whom it may be entrusted in confidence, within the provision of the Official Secrets Acts 1911-1989, is personally responsible for its safe custody and for seeing that its contents are disclosed only to authorized persons).

**CARRIER, PERSONNEL, FULL TRACKED, FV432 MK 2 AND 2/1  
MODIFICATION INSTRUCTION NO. 1 (EMER TV E107/2 Mod Instr No 27)**

**SUBJECT: Drivers switch No.1, MK1**

**CANCELLATION**

**INTRODUCTION**

- 1 AESP 2350-T-251-811 Mod Instr No. 1, EMER TV E107 Mod Instr No.27 dated Mar 66 is hereby cancelled. The details of this modification have been incorporated into the build standard.

**ACTION**

- 2 Amend AESP 2350-T-251-811 Mod Instr No.1, EMER TV E107/2 modification index accordingly
- 3 File this Page 1/2 in place of Mod Instr No. 27 dated Mar 66, all pages of which are to be destroyed.

CONDITIONS OF RELEASE

- |   |   |   |   |
|---|---|---|---|
| 1 | This information is released by the UK Government for Defence purposes only.  | 3 | This information may be disclosed only within the Defence Department of the recipient Government, except as otherwise authorized by Ministry of Defence (Army). |
| 2 | This information must be afforded the same degree of protection as that afforded to information of an equivalent security marking originated by the recipient Government or as required by the recipient Government's security regulations. | 4 | This information may be subject to privately owned rights.  |

THIS DOCUMENT IS THE PROPERTY OF HER BRITANNIC MAJESTY'S GOVERNMENT, and is issued for the information of such persons only as need to know its contents in the course of their official duties. Any person finding this document should hand it to a British forces unit or to a police station for its safe return to the MINISTRY OF DEFENCE (Dsy (Pol)), MAIN BUILDING, WHITEHALL, LONDON SW1A 2HB with particulars of how and where found. THE UNAUTHORIZED RETENTION OR DESTRUCTION OF THIS DOCUMENT MAY BE AN OFFENCE UNDER THE OFFICIAL SECRETS ACTS OF 1911-1989. (When released to persons outside Government service, this document is issued on a personal basis and the recipient to whom it may be entrusted in confidence, within the provision of the Official Secrets Acts 1911-1989, is personally responsible for its safe custody and for seeing that its contents are disclosed only to authorized persons).

**CARRIER, PERSONNEL, FULL TRACKED, FV 432 MK 2 AND 2/1**

**MODIFICATION INSTRUCTION NO. 1**

---

**SUBJECT: Carl Gustave fittings**

**CANCELLATION**

**INTRODUCTION**

1 AESP 2350-T-251-811 Mod Instr No. 1, EMER E107/2 Mod Instr 28 is hereby cancelled. This modification was applicable to equipment that has been declared obsolete, and is therefore no longer required.

**ACTION**

- 2 Amend AESP 2350-T-251-811 Mod Instr 1, EMER E107/2 modification index accordingly.
- 3 File this Page 1/2 in place of Mod Instr No. 28 dated Jul 66, all pages of which are to be destroyed.

CONDITIONS OF RELEASE

- |   |   |   |   |
|---|---|---|---|
| 1 | This information is released by the UK Government for Defence purposes only.  | 3 | This information may be disclosed only within the Defence Department of the recipient Government, except as otherwise authorized by Ministry of Defence (Army). |
| 2 | This information must be afforded the same degree of protection as that afforded to information of an equivalent security marking originated by the recipient Government or as required by the recipient Government's security regulations. | 4 | This information may be subject to privately owned rights.  |

THIS DOCUMENT IS THE PROPERTY OF HER BRITANNIC MAJESTY'S GOVERNMENT, and is issued for the information of such persons only as need to know its contents in the course of their official duties. Any person finding this document should hand it to a British forces unit or to a police station for its safe return to the MINISTRY OF DEFENCE (Dsy (Pol)), MAIN BUILDING, WHITEHALL, LONDON SW1A 2HB with particulars of how and where found. THE UNAUTHORIZED RETENTION OR DESTRUCTION OF THIS DOCUMENT MAY BE AN OFFENCE UNDER THE OFFICIAL SECRETS ACTS OF 1911-1989. (When released to persons outside Government service, this document is issued on a personal basis and the recipient to whom it may be entrusted in confidence, within the provision of the Official Secrets Acts 1911-1989, is personally responsible for its safe custody and for seeing that its contents are disclosed only to authorized persons).

**CARRIER, PERSONNEL, FULL TRACKED, FV 432 MK 2 AND 2/1**

**MODIFICATION INSTRUCTION NO. 1**

---

**SUBJECT: Hull adaption for radio**

**CANCELLATION**

**INTRODUCTION**

1 AESP 2350-T-251-811 Mod Instr No. 1, EMER E107/2 Mod Instr 29 is hereby cancelled. This modification is applicable to Mk 1 vehicles only.

**ACTION**

- 2 Amend AESP 2350-T-251-811 Mod Instr 1, EMER E107/2 modification index accordingly.
- 3 File this Page 1/2 in place of Mod Instr No. 29 dated Jul 66, all pages of which are to be destroyed.

CONDITIONS OF RELEASE	
1 This information is released by the UK Government to the recipient Government for Defence purposes only	3 This information may be disclosed only within the Defence Department of the recipient Government, except as otherwise authorised by Ministry of Defence (Army)
2 This information must be accorded the same degree of security protection as that accorded thereto by the UK Government	4 This information may be subject to privately owned rights

THIS DOCUMENT IS THE PROPERTY OF HER BRITANNIC MAJESTY'S GOVERNMENT, and is issued for the information of such persons only as need to know its contents in the course of their official duties. Any person finding this document should hand it into a British forces unit or to a police station for its safe return to the MINISTRY OF DEFENCE D.MOD 5y LONDON SW1A 2HS with particulars of how and where found. THE UNAUTHORISED RETENTION OR DESTRUCTION OF THE DOCUMENT IS AN OFFENCE UNDER THE OFFICIAL SECRETS ACTS OF 1911-1939. (When released to persons outside Government service, this document is issued on a personal basis and the recipient to whom it is entrusted in confidence, within the provisions of the Official Secrets Acts 1911-1939, is personally responsible for its safe custody and for seeing that its contents are disclosed only to authorised persons).

CARRIER, PERSONNEL, FULL TRACKED, MK 1, 1/1, 2 AND 2/1 (FV 432)

TECHNICAL HANDBOOK - MODIFICATION INSTRUCTION

Note: This Issue 2, supersedes Issue 1, Pages 1-3 dated Jun 66.

SUBJECT: Floatation platform, drainage  
(MVEE Approval 21486)

CANCELLATION

1. This modification instruction has been cancelled under the authority of 'A' Veh D&M Committee Approvals 31040/31041.
2. Salvage any useful items from modification kit and return to maintenance stock, scrap remaining items and dispose of through normal channels.
3. Remove all copies of Issue 1, Pages 1-3 of this instruction and destroy.
4. Against subject reference in modification instruction index and add 'Cancelled'.

END

70811 (216)  
Veh & Wpns Br REME ALM/43000

CONDITIONS OF RELEASE

- |   |   |   |   |
|---|---|---|---|
| 1 | This information is released by the UK Government for Defence purposes only.  | 3 | This information may be disclosed only within the Defence Department of the recipient Government, except as otherwise authorized by Ministry of Defence (Army). |
| 2 | This information must be afforded the same degree of protection as that afforded to information of an equivalent security marking originated by the recipient Government or as required by the recipient Government's security regulations. | 4 | This information may be subject to privately owned rights.  |

THIS DOCUMENT IS THE PROPERTY OF HER BRITANNIC MAJESTY'S GOVERNMENT, and is issued for the information of such persons only as need to know its contents in the course of their official duties. Any person finding this document should hand it to a British forces unit or to a police station for its safe return to the MINISTRY OF DEFENCE (Dsy (Pol)), MAIN BUILDING, WHITEHALL, LONDON SW1A 2HB with particulars of how and where found. THE UNAUTHORIZED RETENTION OR DESTRUCTION OF THIS DOCUMENT MAY BE AN OFFENCE UNDER THE OFFICIAL SECRETS ACTS OF 1911-1989. (When released to persons outside Government service, this document is issued on a personal basis and the recipient to whom it may be entrusted in confidence, within the provision of the Official Secrets Acts 1911-1989, is personally responsible for its safe custody and for seeing that its contents are disclosed only to authorized persons).

**CARRIER, PERSONNEL, FULL TRACKED, FV 432 MK 2 AND 2/1**

**MODIFICATION INSTRUCTION NO. 1**

---

**SUBJECT: Fuel system**

**CANCELLATION**

**INTRODUCTION**

1 AESP 2350-T-251-811 Mod Instr No. 1, EMER E107/2 Mod Instr 31 is hereby cancelled. The details of this modification have been incorporated into the build standard.

**ACTION**

- 2 Amend AESP 2350-T-251-811 Mod Instr 1, EMER E107/2 modification index accordingly.
- 3 File this Page 1/2 in place of Mod Instr No. 31 dated Jun 66, all pages of which are to be destroyed.

CONDITIONS OF RELEASE

- |   |   |   |   |
|---|---|---|---|
| 1 | This information is released by the UK Government for Defence purposes only.  | 3 | This information may be disclosed only within the Defence Department of the recipient Government, except as otherwise authorized by Ministry of Defence (Army). |
| 2 | This information must be afforded the same degree of protection as that afforded to information of an equivalent security marking originated by the recipient Government or as required by the recipient Government's security regulations. | 4 | This information may be subject to privately owned rights.  |

THIS DOCUMENT IS THE PROPERTY OF HER BRITANNIC MAJESTY'S GOVERNMENT, and is issued for the information of such persons only as need to know its contents in the course of their official duties. Any person finding this document should hand it to a British forces unit or to a police station for its safe return to the MINISTRY OF DEFENCE (Dsy (Pol)), MAIN BUILDING, WHITEHALL, LONDON SW1A 2HB with particulars of how and where found. THE UNAUTHORIZED RETENTION OR DESTRUCTION OF THIS DOCUMENT MAY BE AN OFFENCE UNDER THE OFFICIAL SECRETS ACTS OF 1911-1989. (When released to persons outside Government service, this document is issued on a personal basis and the recipient to whom it may be entrusted in confidence, within the provision of the Official Secrets Acts 1911-1989, is personally responsible for its safe custody and for seeing that its contents are disclosed only to authorized persons).

**CARRIER, PERSONNEL, FULL TRACKED, FV 432 MK 2 AND 2/1**

**MODIFICATION INSTRUCTION NO. 1**

---

**SUBJECT: Hull, rear door**

**CANCELLATION**

**INTRODUCTION**

1 AESP 2350-T-251-811 Mod Instr No. 1, EMER E107/2 Mod Instr 32 is hereby cancelled. The details of this modification have been incorporated into the build standard.

**ACTION**

- 2 Amend AESP 2350-T-251-811 Mod Instr 1, EMER E107/2 modification index accordingly.
- 3 File this Page 1/2 in place of Mod Instr No. 32 dated Jun 66, all pages of which are to be destroyed.



**CONDITIONS OF RELEASE**

- |   |   |
|---|---|
| 1 This information is released by the UK Government for Defence purposes only.  | 3 This information may be disclosed only within the Defence Department of the recipient Government, except as otherwise authorized by Ministry of Defence (Army). |
| 2 This information must be afforded the same degree of protection as that afforded to information of an equivalent security marking originated by the recipient Government or as required by the recipient Government's security regulations. | 4 This information may be subject to privately owned rights.  |

THIS DOCUMENT IS THE PROPERTY OF HER BRITANNIC MAJESTY'S GOVERNMENT, and is issued for the information of such persons only as need to know its contents in the course of their official duties. Any person finding this document should hand it to a British forces unit or to a police station for its safe return to the MINISTRY OF DEFENCE (Dsy (Pol)), MAIN BUILDING, WHITEHALL, LONDON SW1A 2HB with particulars of how and where found. THE UNAUTHORIZED RETENTION OR DESTRUCTION OF THIS DOCUMENT MAY BE AN OFFENCE UNDER THE OFFICIAL SECRETS ACTS OF 1911-1989. (When released to persons outside Government service, this document is issued on a personal basis and the recipient to whom it may be entrusted in confidence, within the provision of the Official Secrets Acts 1911-1989, is personally responsible for its safe custody and for seeing that its contents are disclosed only to authorized persons).

**CARRIER, PERSONNEL, FULL TRACKED, FV432 MK 2 AND 2/1  
MODIFICATION INSTRUCTION NO. 1 (EMER TV E107/2 Mod Instr No 33)**

**SUBJECT: Fire warning system**

**CANCELLATION**

**INTRODUCTION**

- 1 AESP 2350-T-251-811 Mod Instr No. 1, EMER TV E107 Mod Instr No.33 dated Jul 66 is hereby cancelled. The details of this modification have been incorporated into the build standard.

**ACTION**

- 2 Amend AESP 2350-T-251-811 Mod Instr No.1, EMER TV E107/2 modification index accordingly
- 3 File this Page 1/2 in place of Mod Instr No. 33 dated Jul 66, all pages of which are to be destroyed.

CARRIER, PERSONNEL, FULL TRACKED, FV 432, MK 1, 2 AND 2/1

TECHNICAL HANDBOOK - MODIFICATION INSTRUCTION

SUB-TITLE: Cupola machine gun mounting.

1. Introduction To secure alternative MG's whilst travelling, two hinge blocks are welded to cupola plating.
2. Priority Group 'B' (Gen H 097 refers)
3. Estimated time required 2 man-hours
4. Vehicles affected W.D. No 02EA00 to 12EA00
5. Item affected Cupola plate
6. Action required by:-
  - a. Units and establishments holding equipment
    - (1) Enter EMER No and sub-title in the AB 413.
    - (2) Request REME to modify equipment.
  - b. Units authorized to carry out unit or field repairs
    - (1) When requested by units, carry out this modification.
    - (2) Record completion of the modification in AB 413 against appropriate entry.
  - c. All recipients of this EMER  
Add particulars to Tkd Veh E 107/2 Mod Instr Index.
7. Stores, tools and equipment
  - a. Stores to be obtained locally

<u>VAOS, Section</u>	<u>Part No</u>	<u>Designation</u>	<u>Qty per veh</u>
G2	GB 16186	Steel, mild, square 1 in.	1.1/2 in.
G2	GB 16113	Steel, mild, hoop, plate 6 ft x 3 ft x 5/16 in.	5/8 in. x 3.1/2 in.

8. Sequence of operations

- a. See Fig 1. Manufacture two blocks to dimensions given.
- b. Remove periscope from cupola.
- c. See Fig 2. Weld block FV 586390 to cupola platform to dimensions given, using a suitable mandrel to prevent distortion of the holes.
- d. See Fig 3.
  - (1) Weld block FV 586435 to cupola plate to dimensions given.
  - (2) To ensure correct alignment of the holes, reamer out to  $3/8$  in. dia when welding operations are completed.
- e. Paint exposed metal surfaces and grease both block drillings.
- f. Refit periscope to cupola.

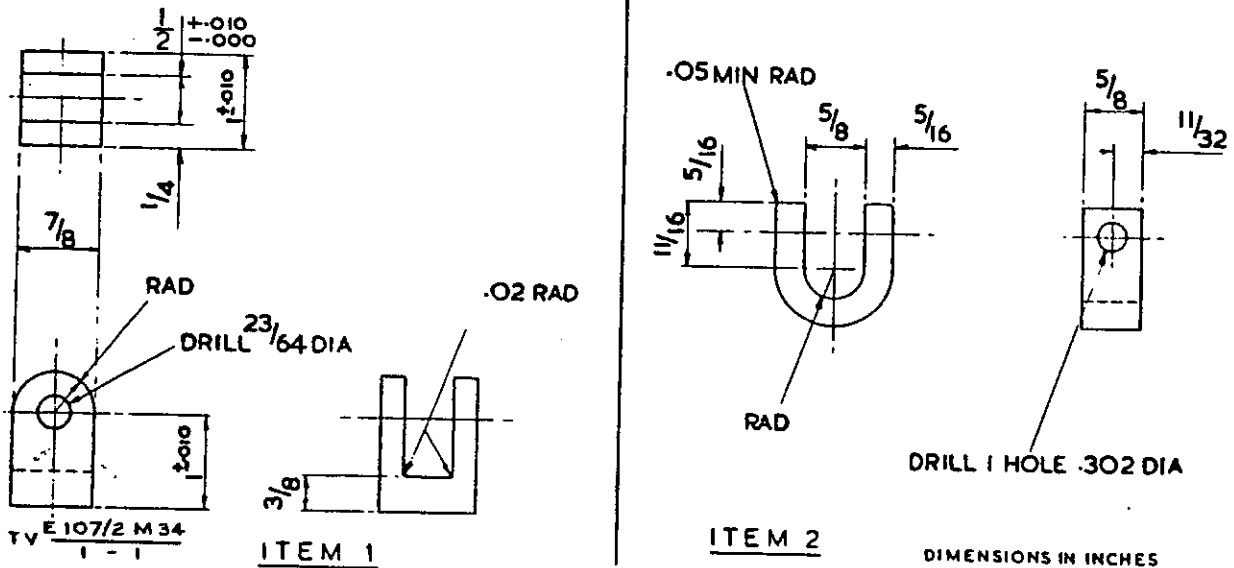

Fig 1 - Blocks - detail

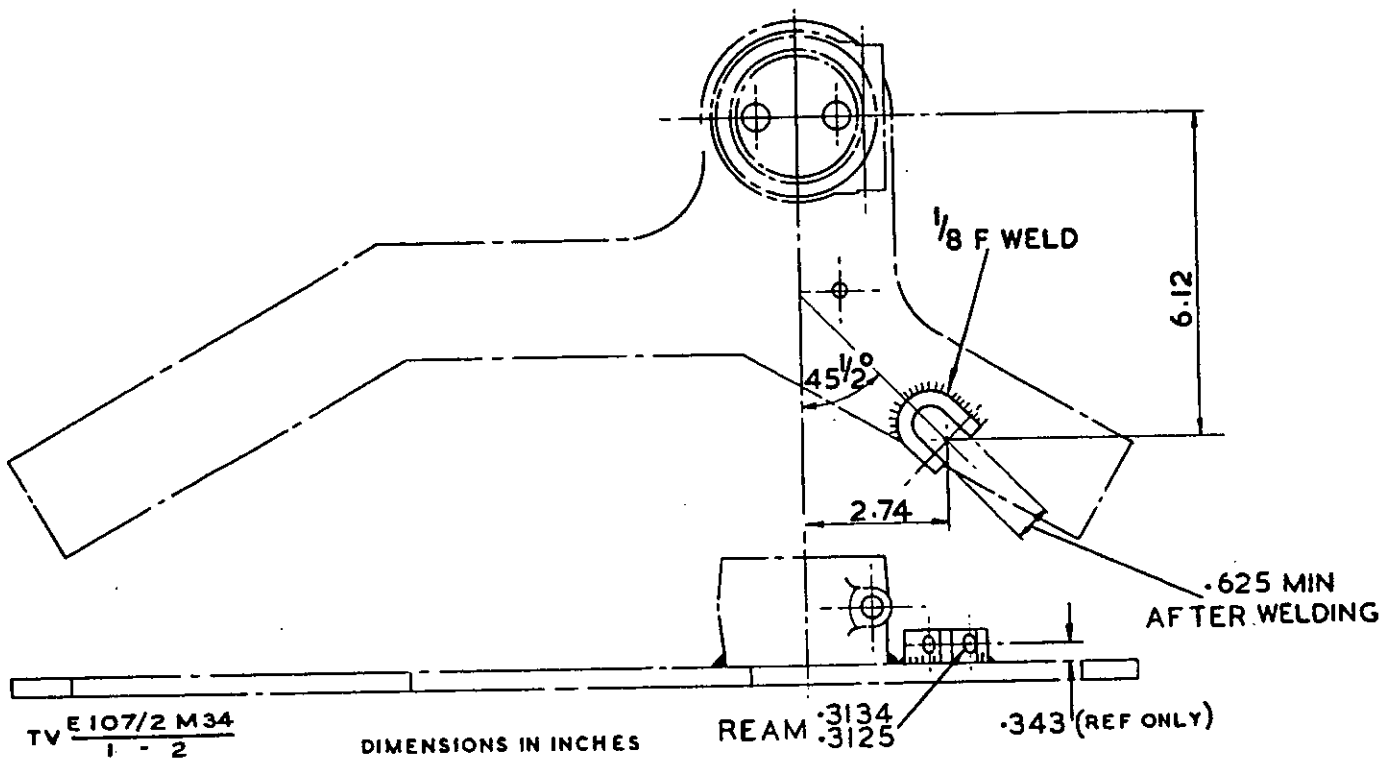

Fig 2 - Platform - welding

FV 524831

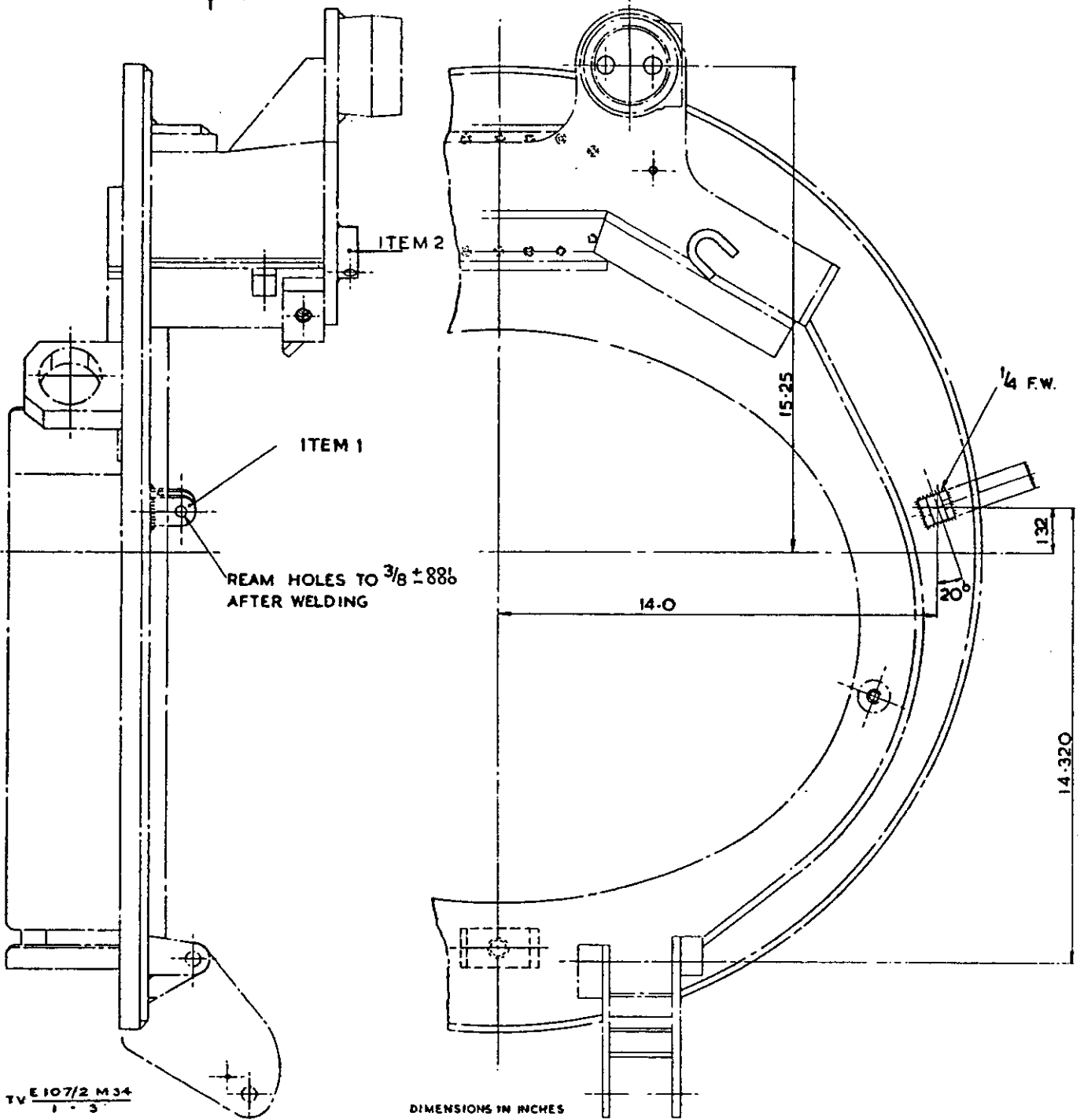

Fig 3 - Cupola plate - welding

70656  
FVRDE Approval 21539  
(Def and Mods)

END

Issue 1, 26 Aug 66

CONDITIONS OF RELEASE

- |   |   |   |   |
|---|---|---|---|
| 1 | This information is released by the UK Government for Defence purposes only.  | 3 | This information may be disclosed only within the Defence Department of the recipient Government, except as otherwise authorized by Ministry of Defence (Army). |
| 2 | This information must be afforded the same degree of protection as that afforded to information of an equivalent security marking originated by the recipient Government or as required by the recipient Government's security regulations. | 4 | This information may be subject to privately owned rights.  |

THIS DOCUMENT IS THE PROPERTY OF HER BRITANNIC MAJESTY'S GOVERNMENT, and is issued for the information of such persons only as need to know its contents in the course of their official duties. Any person finding this document should hand it to a British forces unit or to a police station for its safe return to the MINISTRY OF DEFENCE (Dsy (Pol)), MAIN BUILDING, WHITEHALL, LONDON SW1A 2HB with particulars of how and where found. THE UNAUTHORIZED RETENTION OR DESTRUCTION OF THIS DOCUMENT MAY BE AN OFFENCE UNDER THE OFFICIAL SECRETS ACTS OF 1911-1989. (When released to persons outside Government service, this document is issued on a personal basis and the recipient to whom it may be entrusted in confidence, within the provision of the Official Secrets Acts 1911-1989, is personally responsible for its safe custody and for seeing that its contents are disclosed only to authorized persons).

**CARRIER, PERSONNEL, FULL TRACKED, FV 432 MK 2 AND 2/1**

**MODIFICATION INSTRUCTION NO. 1**

**SUBJECT: Wombat kit**

**CANCELLATION**

**INTRODUCTION**

1 AESP 2350-T-251-811 Mod Instr No. 1, EMER E107/2 Mod Instr 35 is hereby cancelled. This modification was applicable to equipment that has been declared obsolete, and is therefore no longer required.

**ACTION**

- 2 Amend AESP 2350-T-251-811 Mod Instr 1, EMER E107/2 modification index accordingly.
- 3 File this Page 1/2 in place of Mod Instr No. 35 dated Aug 66, all pages of which are to be destroyed.

CONDITIONS OF RELEASE

- |   |   |
|---|---|
| 1 This information is released by the UK Government for Defence purposes only.  | 3 This information may be disclosed only within the Defence Department of the recipient Government, except as otherwise authorized by Ministry of Defence (Army). |
| 2 This information must be afforded the same degree of protection as that afforded to information of an equivalent security marking originated by the recipient Government or as required by the recipient Government's security regulations. | 4 This information may be subject to privately owned rights.  |

THIS DOCUMENT IS THE PROPERTY OF HER BRITANNIC MAJESTY'S GOVERNMENT, and is issued for the information of such persons only as need to know its contents in the course of their official duties. Any person finding this document should hand it to a British forces unit or to a police station for its safe return to the MINISTRY OF DEFENCE (Dsy (Pol)), MAIN BUILDING, WHITEHALL, LONDON SW1A 2HB with particulars of how and where found. THE UNAUTHORIZED RETENTION OR DESTRUCTION OF THIS DOCUMENT MAY BE AN OFFENCE UNDER THE OFFICIAL SECRETS ACTS OF 1911-1989. (When released to persons outside Government service, this document is issued on a personal basis and the recipient to whom it may be entrusted in confidence, within the provision of the Official Secrets Acts 1911-1989, is personally responsible for its safe custody and for seeing that its contents are disclosed only to authorized persons).

**CARRIER, PERSONNEL, FULL TRACKED, FV 432 MK 2 AND 2/1**

**MODIFICATION INSTRUCTION NO. 1**

---

**SUBJECT: Engine coolant thermostat**

**CANCELLATION**

**INTRODUCTION**

1 AESP 2350-T-251-811 Mod Instr No. 1, EMER E107/2 Mod Instr 36 is hereby cancelled. This modification is applicable to Mk 1 vehicles only.

**ACTION**

- 2 Amend AESP 2350-T-251-811 Mod Instr 1, EMER E107/2 modification index accordingly.
- 3 File this Page 1/2 in place of Mod Instr No. 36 dated Sep 66, all pages of which are to be destroyed.

~~RESTRICTED~~

ELECTRICAL AND MECHANICAL  
ENGINEERING REGULATIONS  
(By Command of the Defence Council)

TRACKED VEHICLES  
E 107/2 Mod Instr No 37  
Army Modification Code J 00072

CARRIER, PERSONNEL, FULL TRACKED, FV 432, MK 1, 1/1 AND 2

TECHNICAL HANDBOOK - MODIFICATION INSTRUCTION

Errata

Note: This Page 0 is to be filed immediately in front of Page 1.

1. Amend as follows:-

Page 2, para 7

Delete: 'Note: The item numbers in sub-para 6.a. and b. correspond to those given in Fig 1 key block'.

Insert new note:

'Note: Floor plates have to be removed from vehicle as item 6 and 9 are fitted from underside of plates. Item numbers in para 6 correspond to those shown in Fig 1 key block'.

FVRDE Approval 21430  
(Def and Mods) 70638  
Issue 1, 28 Jun 67

Distribution - Class 291. Code No 2

Page 0



CARRIER, PERSONNEL, FULL TRACKED, MK 1, 1/1 AND 2, FV 432

TECHNICAL HANDBOOK - MODIFICATION INSTRUCTION

SUB-TITLE: Hull floor plate

1. Introduction

To protect existing tapped holes in hull floor plate, blanking off plugs, screws and washers are fitted.

2. Priority Group 'B' (Gen H 097 refers)

3. Estimated time required

Embodiment: 2 man-hours

4. Item affected

Hull, floor plate, in:-	Reg Nos	02EAO1 to 99	06EAO0 to 99
		03EAO0 to 99	07EAO0 to 99
		04EAO0 to 99	08EAO0 to 99
		05EAO0 to 99	09EAO0 to 50

5. Action required by:-

a. Units and establishments holding equipment including TA:-

- (1) Enter EMER No and sub-title in AB 413.
- (2) Demand stores required. Automatic issue will be made to BAOR units.
- (3) On receipt of stores, request REME to modify equipment.

b. Units authorized to carry out unit, field or base repairs:

- (1) When requested by units or during overhaul carry out this modification.
- (2) Record completion of the modification in AB 413 against appropriate entry.

c. All recipients of this EMER:

Add particulars to Tkd Veh E 107/2 Mod Instr Index.

6. Stores, tools and equipment

a. Stores to be demanded

The following stores are to be demanded as a set, (reference to sub-para 5.a. (2), quoting the registration number of the vehicle and this EMER as authority.

<u>Item No</u>	<u>VAOS Section</u>	<u>Part No</u>	<u>Designation</u>	<u>Qty per veh</u>
	LV9/ACR	MOD 21430	Mod Set: Hull floor plate	1
			comprising:-	
1	LV9/ACR	FV 560069	Plug, floor, winch mounting, small	(6)
2	LV9/ACR	FV 560070	Plug, floor, winch mounting, large	(6)
3	LV9/ACR	FV 560071	Plug, floor, mortar mounting	(11)
4	LV9/ACR	FV 560072	Plug, floor, mortar and winch mounting	(1)

b. Stores to be obtained locally

<u>Item No</u>	<u>VAOS Section</u>	<u>Part No</u>	<u>Designation</u>	<u>Qty per veh</u>
5	G1	5305-99-941-0711	Screw, precision, UNC-2A, 'R' steel, hex hd, zinc coated, 3/8 in. x 5/8 in.	7
6	G1	5305-99-941-0713	Screw, precision, UNC-2A, 'R' steel, hex hd, 3/8 in. x 7/8 in.	30
7	G1	5305-99-941-1682	Screw, precision, UNF-2A, 'R' steel, hex hd, zinc coated, 1/4 in. x 1.1/8 in.	1
8	G1	5310-99-944-0555	Washer, lock, steel, s.c., cadmium plated, 3/4 in. x 1.165 in. x 0.176 in. thick	12
9	G1	5310-99-944-0550	Washer, lock, 3/8 in. dia	37
10	G1	5310-99-944-0548	Washer, lock, 1/4 in. dia	1

7. Sequence of operations

See Fig 1 - Fit plugs, screws and washers in tapped holes as shown.

*FLOOR PLATES HAVE TO BE REMOVED FROM VEHICLE AS ITEMS 6 AND 9 ARE FITTED FROM*  
Note: The item numbers in sub-para 6.a. and b. correspond to those UNDERSIDE OF PLATES given in Fig 1 key block.  
*shown*

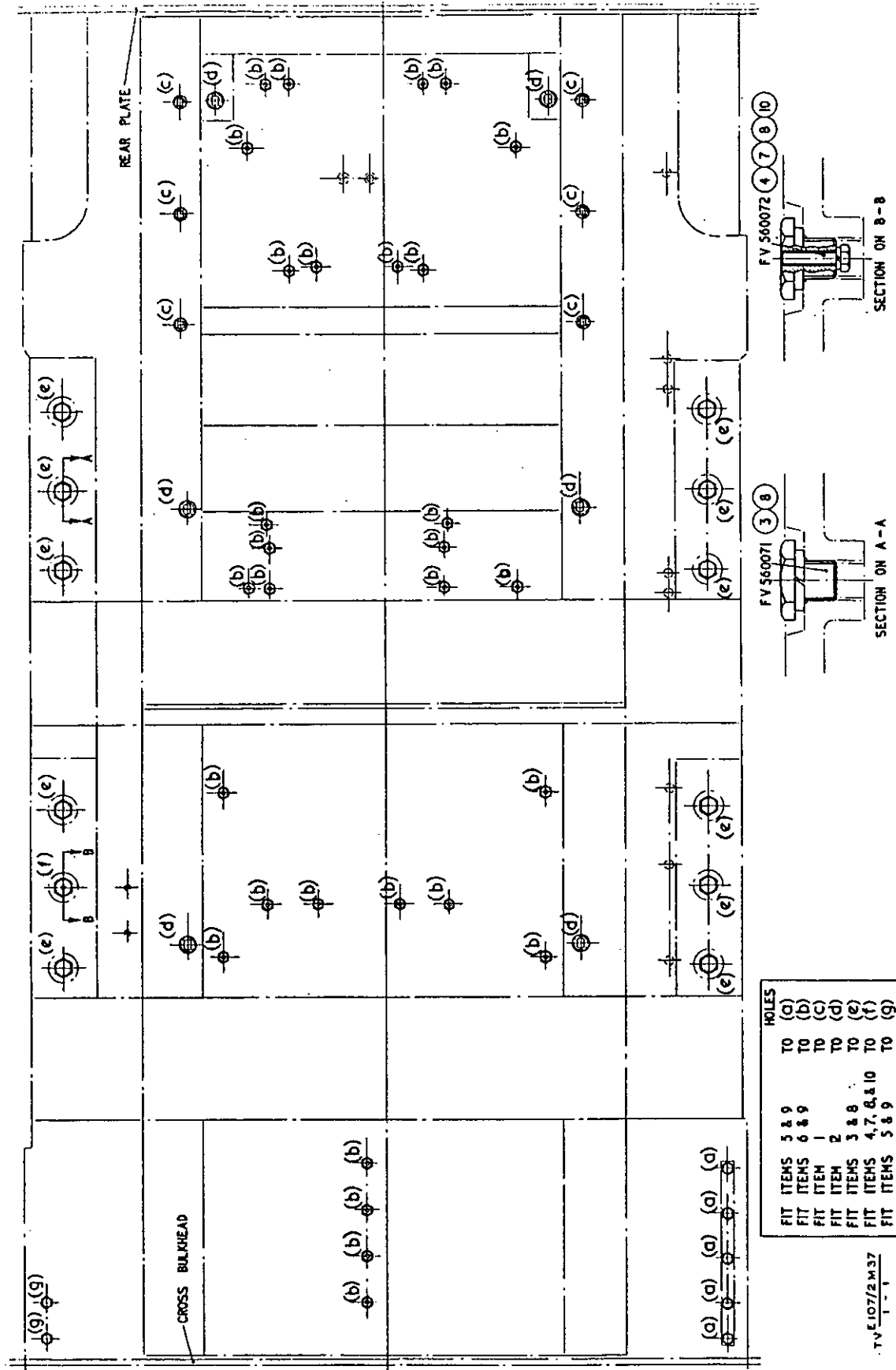

Fig 1 - Fitting of floor plugs - detail

CONDITIONS OF RELEASE

- |   |   |
|---|---|
| 1 This information is released by the UK Government for Defence purposes only.  | 3 This information may be disclosed only within the Defence Department of the recipient Government, except as otherwise authorized by Ministry of Defence (Army). |
| 2 This information must be afforded the same degree of protection as that afforded to information of an equivalent security marking originated by the recipient Government or as required by the recipient Government's security regulations. | 4 This information may be subject to privately owned rights.  |

THIS DOCUMENT IS THE PROPERTY OF HER BRITANNIC MAJESTY'S GOVERNMENT, and is issued for the information of such persons only as need to know its contents in the course of their official duties. Any person finding this document should hand it to a British forces unit or to a police station for its safe return to the MINISTRY OF DEFENCE (Dsy (Pol)), MAIN BUILDING, WHITEHALL, LONDON SW1A 2HB with particulars of how and where found. THE UNAUTHORIZED RETENTION OR DESTRUCTION OF THIS DOCUMENT MAY BE AN OFFENCE UNDER THE OFFICIAL SECRETS ACTS OF 1911-1989. (When released to persons outside Government service, this document is issued on a personal basis and the recipient to whom it may be entrusted in confidence, within the provision of the Official Secrets Acts 1911-1989, is personally responsible for its safe custody and for seeing that its contents are disclosed only to authorized persons).

**CARRIER, PERSONNEL, FULL TRACKED, FV 432 MK 2 AND 2/1**

**MODIFICATION INSTRUCTION NO. 1**

---

**SUBJECT: Drivers hood and hatch protection**

**CANCELLATION**

**INTRODUCTION**

1 AESP 2350-T-251-811 Mod Instr No. 1, EMER E107/2 Mod Instr 38 is hereby cancelled. This modification was applicable to equipment that has been declared obsolete, and is therefore no longer required.

**ACTION**

- 2 Amend AESP 2350-T-251-811 Mod Instr 1, EMER E107/2 modification index accordingly.
- 3 File this Page 1/2 in place of Mod Instr No. 38 dated Sep 69, all pages of which are to be destroyed.

CONDITIONS OF RELEASE

- |   |   |   |   |
|---|---|---|---|
| 1 | This information is released by the UK Government for Defence purposes only.  | 3 | This information may be disclosed only within the Defence Department of the recipient Government, except as otherwise authorized by Ministry of Defence (Army). |
| 2 | This information must be afforded the same degree of protection as that afforded to information of an equivalent security marking originated by the recipient Government or as required by the recipient Government's security regulations. | 4 | This information may be subject to privately owned rights.  |

THIS DOCUMENT IS THE PROPERTY OF HER BRITANNIC MAJESTY'S GOVERNMENT, and is issued for the information of such persons only as need to know its contents in the course of their official duties. Any person finding this document should hand it to a British forces unit or to a police station for its safe return to the MINISTRY OF DEFENCE (Dsy (Pol)), MAIN BUILDING, WHITEHALL, LONDON SW1A 2HB with particulars of how and where found. THE UNAUTHORIZED RETENTION OR DESTRUCTION OF THIS DOCUMENT MAY BE AN OFFENCE UNDER THE OFFICIAL SECRETS ACTS OF 1911-1989. (When released to persons outside Government service, this document is issued on a personal basis and the recipient to whom it may be entrusted in confidence, within the provision of the Official Secrets Acts 1911-1989, is personally responsible for its safe custody and for seeing that its contents are disclosed only to authorized persons).

**CARRIER, PERSONNEL, FULL TRACKED, FV 432 MK 2 AND 2/1**

**MODIFICATION INSTRUCTION NO. 1**

---

**SUBJECT: Wombat kit**

**CANCELLATION**

**INTRODUCTION**

1 AESP 2350-T-251-811 Mod Instr No. 1, EMER E107/2 Mod Instr 39 is hereby cancelled. This modification was applicable to equipment that has been declared obsolete, and is therefore no longer required.

**ACTION**

- 2 Amend AESP 2350-T-251-811 Mod Instr 1, EMER E107/2 modification index accordingly.
- 3 File this Page 1/2 in place of Mod Instr No. 39 dated Jan 67, all pages of which are to be destroyed.

CONDITIONS OF RELEASE

- |   |   |   |   |
|---|---|---|---|
| 1 | This information is released by the UK Government for Defence purposes only.  | 3 | This information may be disclosed only within the Defence Department of the recipient Government, except as otherwise authorized by Ministry of Defence (Army). |
| 2 | This information must be afforded the same degree of protection as that afforded to information of an equivalent security marking originated by the recipient Government or as required by the recipient Government's security regulations. | 4 | This information may be subject to privately owned rights.  |

THIS DOCUMENT IS THE PROPERTY OF HER BRITANNIC MAJESTY'S GOVERNMENT, and is issued for the information of such persons only as need to know its contents in the course of their official duties. Any person finding this document should hand it to a British forces unit or to a police station for its safe return to the MINISTRY OF DEFENCE (Dsy (Pol)), MAIN BUILDING, WHITEHALL, LONDON SW1A 2HB with particulars of how and where found. THE UNAUTHORIZED RETENTION OR DESTRUCTION OF THIS DOCUMENT MAY BE AN OFFENCE UNDER THE OFFICIAL SECRETS ACTS OF 1911-1989. (When released to persons outside Government service, this document is issued on a personal basis and the recipient to whom it may be entrusted in confidence, within the provision of the Official Secrets Acts 1911-1989, is personally responsible for its safe custody and for seeing that its contents are disclosed only to authorized persons).

**CARRIER, PERSONNEL, FULL TRACKED, FV 432 MK 2 AND 2/1**

**MODIFICATION INSTRUCTION NO. 1**

---

**SUBJECT: Driving mirrors**

**CANCELLATION**

**INTRODUCTION**

1 AESP 2350-T-251-811 Mod Instr No. 1, EMER E107/2 Mod Instr 40 is hereby cancelled. This modification has been superseded by AESP 2350-T-250-811 Mod Instr No. 3.

**ACTION**

- 2 Amend AESP 2350-T-251-811 Mod Instr 1, EMER E 107/2 modification index accordingly.
- 3 File this Page 1/2 in place of Mod Instr No. 40 dated Jan 67, all pages of which are to be destroyed.

CONDITIONS OF RELEASE

- |   |   |   |   |
|---|---|---|---|
| 1 | This information is released by the UK Government for Defence purposes only.  | 3 | This information may be disclosed only within the Defence Department of the recipient Government, except as otherwise authorized by Ministry of Defence (Army). |
| 2 | This information must be afforded the same degree of protection as that afforded to information of an equivalent security marking originated by the recipient Government or as required by the recipient Government's security regulations. | 4 | This information may be subject to privately owned rights.  |

THIS DOCUMENT IS THE PROPERTY OF HER BRITANNIC MAJESTY'S GOVERNMENT, and is issued for the information of such persons only as need to know its contents in the course of their official duties. Any person finding this document should hand it to a British forces unit or to a police station for its safe return to the MINISTRY OF DEFENCE (Dsy (Pol)), MAIN BUILDING, WHITEHALL, LONDON SW1A 2HB with particulars of how and where found. THE UNAUTHORIZED RETENTION OR DESTRUCTION OF THIS DOCUMENT MAY BE AN OFFENCE UNDER THE OFFICIAL SECRETS ACTS OF 1911-1989. (When released to persons outside Government service, this document is issued on a personal basis and the recipient to whom it may be entrusted in confidence, within the provision of the Official Secrets Acts 1911-1989, is personally responsible for its safe custody and for seeing that its contents are disclosed only to authorized persons).

**CARRIER, PERSONNEL, FULL TRACKED, FV 432 MK 2 AND 2/1**

**MODIFICATION INSTRUCTION NO. 1**

---

**SUBJECT: Wombat kit**

**CANCELLATION**

**INTRODUCTION**

1 AESP 2350-T-251-811 Mod Instr No. 1, EMER E107/2 Mod Instr 41 is hereby cancelled. This modification was applicable to equipment that has been declared obsolete, and is therefore no longer required.

**ACTION**

- 2 Amend AESP 2350-T-251-811 Mod Instr 1, EMER E107/2 modification index accordingly.
- 3 File this Page 1/2 in place of Mod Instr No. 41 dated Jul 68, all pages of which are to be destroyed.

CONDITIONS OF RELEASE

- |   |   |   |   |
|---|---|---|---|
| 1 | This information is released by the UK Government for Defence purposes only.  | 3 | This information may be disclosed only within the Defence Department of the recipient Government, except as otherwise authorized by Ministry of Defence (Army). |
| 2 | This information must be afforded the same degree of protection as that afforded to information of an equivalent security marking originated by the recipient Government or as required by the recipient Government's security regulations. | 4 | This information may be subject to privately owned rights.  |

THIS DOCUMENT IS THE PROPERTY OF HER BRITANNIC MAJESTY'S GOVERNMENT, and is issued for the information of such persons only as need to know its contents in the course of their official duties. Any person finding this document should hand it to a British forces unit or to a police station for its safe return to the MINISTRY OF DEFENCE (Dsy (Pol)), MAIN BUILDING, WHITEHALL, LONDON SW1A 2HB with particulars of how and where found. THE UNAUTHORIZED RETENTION OR DESTRUCTION OF THIS DOCUMENT MAY BE AN OFFENCE UNDER THE OFFICIAL SECRETS ACTS OF 1911-1989. (When released to persons outside Government service, this document is issued on a personal basis and the recipient to whom it may be entrusted in confidence, within the provision of the Official Secrets Acts 1911-1989, is personally responsible for its safe custody and for seeing that its contents are disclosed only to authorized persons).

**CARRIER, PERSONNEL, FULL TRACKED, FV 432 MK 2 AND 2/1**

**MODIFICATION INSTRUCTION NO. 1**

---

**SUBJECT: Accelerator control lubrication**

**CANCELLATION**

**INTRODUCTION**

1 AESP 2350-T-251-811 Mod Instr No. 1, EMER E107/2 Mod Instr 42 is hereby cancelled. The details of this modification have been incorporated into the build standard.

**ACTION**

- 2 Amend AESP 2350-T-251-811 Mod Instr 1, EMER E107/2 modification index accordingly.
- 3 File this Page 1/2 in place of Mod Instr No. 42 dated Jan 67, all pages of which are to be destroyed.



**CONDITIONS OF RELEASE**

- |   |   |   |   |
|---|---|---|---|
| 1 | This information is released by the UK Government for Defence purposes only.  | 3 | This information may be disclosed only within the Defence Department of the recipient Government, except as otherwise authorized by Ministry of Defence (Army). |
| 2 | This information must be afforded the same degree of protection as that afforded to information of an equivalent security marking originated by the recipient Government or as required by the recipient Government's security regulations. | 4 | This information may be subject to privately owned rights.  |

THIS DOCUMENT IS THE PROPERTY OF HER BRITANNIC MAJESTY'S GOVERNMENT, and is issued for the information of such persons only as need to know its contents in the course of their official duties. Any person finding this document should hand it to a British forces unit or to a police station for its safe return to the MINISTRY OF DEFENCE (Dsy (Pol)), MAIN BUILDING, WHITEHALL, LONDON SW1A 2HB with particulars of how and where found. THE UNAUTHORIZED RETENTION OR DESTRUCTION OF THIS DOCUMENT MAY BE AN OFFENCE UNDER THE OFFICIAL SECRETS ACTS OF 1911-1989. (When released to persons outside Government service, this document is issued on a personal basis and the recipient to whom it may be entrusted in confidence, within the provision of the Official Secrets Acts 1911-1989, is personally responsible for its safe custody and for seeing that its contents are disclosed only to authorized persons).

**CARRIER, PERSONNEL, FULL TRACKED, FV432 MK 2 AND 2/1  
MODIFICATION INSTRUCTION NO. 1 (EMER TV E107/2 Mod Instr No 43)**

**SUBJECT: Power pack fuel pipes**

**CANCELLATION**

**INTRODUCTION**

- 1 AESP 2350-T-251-811 Mod Instr No. 1, EMER TV E107 Mod Instr No.43 dated Aug 67 is hereby cancelled. The details of this modification have been incorporated into the build standard.

**ACTION**

- 2 Amend AESP 2350-T-251-811 Mod Instr No.1, EMER TV E107/2 modification index accordingly
- 3 File this Page 1/2 in place of Mod Instr No. 43 dated Aug 67, all pages of which are to be destroyed.

**CONDITIONS OF RELEASE**

- |   |   |   |   |
|---|---|---|---|
| 1 | This information is released by the UK Government for Defence purposes only.  | 3 | This information may be disclosed only within the Defence Department of the recipient Government, except as otherwise authorized by Ministry of Defence (Army). |
| 2 | This information must be afforded the same degree of protection as that afforded to information of an equivalent security marking originated by the recipient Government or as required by the recipient Government's security regulations. | 4 | This information may be subject to privately owned rights.  |

THIS DOCUMENT IS THE PROPERTY OF HER BRITANNIC MAJESTY'S GOVERNMENT, and is issued for the information of such persons only as need to know its contents in the course of their official duties. Any person finding this document should hand it to a British forces unit or to a police station for its safe return to the MINISTRY OF DEFENCE (Dsy (Pol)), MAIN BUILDING, WHITEHALL, LONDON SW1A 2HB with particulars of how and where found. THE UNAUTHORIZED RETENTION OR DESTRUCTION OF THIS DOCUMENT MAY BE AN OFFENCE UNDER THE OFFICIAL SECRETS ACTS OF 1911-1989. (When released to persons outside Government service, this document is issued on a personal basis and the recipient to whom it may be entrusted in confidence, within the provision of the Official Secrets Acts 1911-1989, is personally responsible for its safe custody and for seeing that its contents are disclosed only to authorized persons).

**CARRIER, PERSONNEL, FULL TRACKED, FV432 MK 2 AND 2/1  
MODIFICATION INSTRUCTION NO. 1 (EMER TV E107/2 Mod Instr No 44)**

**SUBJECT: Radiator vent tube extended**

**CANCELLATION**

**INTRODUCTION**

- 1 AESP 2350-T-251-811 Mod Instr No. 1, EMER TV E107 Mod Instr No.44 dated May 68 is hereby cancelled. The details of this modification have been incorporated into the build standard.

**ACTION**

- 2 Amend AESP 2350-T-251-811 Mod Instr No.1, EMER TV E107/2 modification index accordingly
- 3 File this Page 1/2 in place of Mod Instr No. 44 dated May 68, all pages of which are to be destroyed.

CONDITIONS OF RELEASE

- |   |   |   |   |
|---|---|---|---|
| 1 | This information is released by the UK Government for Defence purposes only.  | 3 | This information may be disclosed only within the Defence Department of the recipient Government, except as otherwise authorized by Ministry of Defence (Army). |
| 2 | This information must be afforded the same degree of protection as that afforded to information of an equivalent security marking originated by the recipient Government or as required by the recipient Government's security regulations. | 4 | This information may be subject to privately owned rights.  |

THIS DOCUMENT IS THE PROPERTY OF HER BRITANNIC MAJESTY'S GOVERNMENT, and is issued for the information of such persons only as need to know its contents in the course of their official duties. Any person finding this document should hand it to a British forces unit or to a police station for its safe return to the MINISTRY OF DEFENCE (Dsy (Pol)), MAIN BUILDING, WHITEHALL, LONDON SW1A 2HB with particulars of how and where found. THE UNAUTHORIZED RETENTION OR DESTRUCTION OF THIS DOCUMENT MAY BE AN OFFENCE UNDER THE OFFICIAL SECRETS ACTS OF 1911-1989. (When released to persons outside Government service, this document is issued on a personal basis and the recipient to whom it may be entrusted in confidence, within the provision of the Official Secrets Acts 1911-1989, is personally responsible for its safe custody and for seeing that its contents are disclosed only to authorized persons).

**CARRIER, PERSONNEL, FULL TRACKED, FV 432 MK 2 AND 2/1**

**MODIFICATION INSTRUCTION NO. 1**

---

**SUBJECT: Commander's and driver's hatches**

**CANCELLATION**

**INTRODUCTION**

1 AESP 2350-T-251-811 Mod Instr No. 1, EMER E107/2 Mod Instr 45 is hereby cancelled. The details of this modification have been incorporated into the build standard.

**ACTION**

- 2 Amend AESP 2350-T-251-811 Mod Instr 1, EMER E107/2 modification index accordingly.
- 3 File this Page 1/2 in place of Mod Instr No. 45 dated Jun 67, all pages of which are to be destroyed.

**CONDITIONS OF RELEASE**

- |   |   |   |   |
|---|---|---|---|
| 1 | This information is released by the UK Government for Defence purposes only.  | 3 | This information may be disclosed only within the Defence Department of the recipient Government, except as otherwise authorized by Ministry of Defence (Army). |
| 2 | This information must be afforded the same degree of protection as that afforded to information of an equivalent security marking originated by the recipient Government or as required by the recipient Government's security regulations. | 4 | This information may be subject to privately owned rights.  |

THIS DOCUMENT IS THE PROPERTY OF HER BRITANNIC MAJESTY'S GOVERNMENT, and is issued for the information of such persons only as need to know its contents in the course of their official duties. Any person finding this document should hand it to a British forces unit or to a police station for its safe return to the MINISTRY OF DEFENCE (Dsy (Pol)), MAIN BUILDING, WHITEHALL, LONDON SW1A 2HB with particulars of how and where found. THE UNAUTHORIZED RETENTION OR DESTRUCTION OF THIS DOCUMENT MAY BE AN OFFENCE UNDER THE OFFICIAL SECRETS ACTS OF 1911-1989. (When released to persons outside Government service, this document is issued on a personal basis and the recipient to whom it may be entrusted in confidence, within the provision of the Official Secrets Acts 1911-1989, is personally responsible for its safe custody and for seeing that its contents are disclosed only to authorized persons).

**CARRIER, PERSONNEL, FULL TRACKED, FV432 MK 2 AND 2/1  
MODIFICATION INSTRUCTION NO. 1 (EMER TV E107/2 Mod Instr No 46)**

**SUBJECT: Vehicle radio harness**

**CANCELLATION**

**INTRODUCTION**

- 1 AESP 2350-T-251-811 Mod Instr No. 1, EMER TV E107 Mod Instr No.46 dated Jan 67 is hereby cancelled. The details of this modification have been incorporated into the build standard.

**ACTION**

- 2 Amend AESP 2350-T-251-811 Mod Instr No.1, EMER TV E107/2 modification index accordingly
- 3 File this Page 1/2 in place of Mod Instr No. 46 dated Jan 67, all pages of which are to be destroyed.

**CONDITIONS OF RELEASE**

- |   |   |   |   |
|---|---|---|---|
| 1 | This information is released by the UK Government for Defence purposes only.  | 3 | This information may be disclosed only within the Defence Department of the recipient Government, except as otherwise authorized by Ministry of Defence (Army). |
| 2 | This information must be afforded the same degree of protection as that afforded to information of an equivalent security marking originated by the recipient Government or as required by the recipient Government's security regulations. | 4 | This information may be subject to privately owned rights.  |

THIS DOCUMENT IS THE PROPERTY OF HER BRITANNIC MAJESTY'S GOVERNMENT, and is issued for the information of such persons only as need to know its contents in the course of their official duties. Any person finding this document should hand it to a British forces unit or to a police station for its safe return to the MINISTRY OF DEFENCE (Dsy (Pol)), MAIN BUILDING, WHITEHALL, LONDON SW1A 2HB with particulars of how and where found. THE UNAUTHORIZED RETENTION OR DESTRUCTION OF THIS DOCUMENT MAY BE AN OFFENCE UNDER THE OFFICIAL SECRETS ACTS OF 1911-1989. (When released to persons outside Government service, this document is issued on a personal basis and the recipient to whom it may be entrusted in confidence, within the provision of the Official Secrets Acts 1911-1989, is personally responsible for its safe custody and for seeing that its contents are disclosed only to authorized persons).

**CARRIER, PERSONNEL, FULL TRACKED, FV432 MK 2 AND 2/1  
MODIFICATION INSTRUCTION NO. 1 (EMER TV E107/2 Mod Instr No 47)**

**SUBJECT: Adaption of radio support tray**

**CANCELLATION**

**INTRODUCTION**

- 1 AESP 2350-T-251-811 Mod Instr No. 1, EMER TV E107 Mod Instr No.47 dated Feb 67 is hereby cancelled. The details of this modification have been incorporated into the build standard.

**ACTION**

- 2 Amend AESP 2350-T-251-811 Mod Instr No.1, EMER TV E107/2 modification index accordingly
- 3 File this Page 1/2 in place of Mod Instr No. 47 dated Feb 67, all pages of which are to be destroyed.

CONDITIONS OF RELEASE

- |   |   |
|---|---|
| 1 This information is released by the UK Government for Defence purposes only.  | 3 This information may be disclosed only within the Defence Department of the recipient Government, except as otherwise authorized by Ministry of Defence (Army). |
| 2 This information must be afforded the same degree of protection as that afforded to information of an equivalent security marking originated by the recipient Government or as required by the recipient Government's security regulations. | 4 This information may be subject to privately owned rights.  |

THIS DOCUMENT IS THE PROPERTY OF HER BRITANNIC MAJESTY'S GOVERNMENT, and is issued for the information of such persons only as need to know its contents in the course of their official duties. Any person finding this document should hand it to a British forces unit or to a police station for its safe return to the MINISTRY OF DEFENCE (Dsy (Pol)), MAIN BUILDING, WHITEHALL, LONDON SW1A 2HB with particulars of how and where found. THE UNAUTHORIZED RETENTION OR DESTRUCTION OF THIS DOCUMENT MAY BE AN OFFENCE UNDER THE OFFICIAL SECRETS ACTS OF 1911-1989. (When released to persons outside Government service, this document is issued on a personal basis and the recipient to whom it may be entrusted in confidence, within the provision of the Official Secrets Acts 1911-1989, is personally responsible for its safe custody and for seeing that its contents are disclosed only to authorized persons).

**CARRIER, PERSONNEL, FULL TRACKED, FV 432 MK 2 AND 2/1**

**MODIFICATION INSTRUCTION NO. 1**

---

**SUBJECT: Mortar hatch sealing**

**CANCELLATION**

**INTRODUCTION**

1 AESP 2350-T-251-811 Mod Instr No. 1, EMER E107/2 Mod Instr 48 is hereby cancelled. The details of this modification have been incorporated into the build standard.

**ACTION**

- 2 Amend AESP 2350-T-251-811 Mod Instr 1, EMER E107/2 modification index accordingly.
- 3 File this Page 1/2 in place of Mod Instr No. 48 dated Apr 67, all pages of which are to be destroyed.

CONDITIONS OF RELEASE

- |   |   |   |   |
|---|---|---|---|
| 1 | This information is released by the UK Government for Defence purposes only.  | 3 | This information may be disclosed only within the Defence Department of the recipient Government, except as otherwise authorized by Ministry of Defence (Army). |
| 2 | This information must be afforded the same degree of protection as that afforded to information of an equivalent security marking originated by the recipient Government or as required by the recipient Government's security regulations. | 4 | This information may be subject to privately owned rights.  |

THIS DOCUMENT IS THE PROPERTY OF HER BRITANNIC MAJESTY'S GOVERNMENT, and is issued for the information of such persons only as need to know its contents in the course of their official duties. Any person finding this document should hand it to a British forces unit or to a police station for its safe return to the MINISTRY OF DEFENCE (Dsy (Pol)), MAIN BUILDING, WHITEHALL, LONDON SW1A 2HB with particulars of how and where found. THE UNAUTHORIZED RETENTION OR DESTRUCTION OF THIS DOCUMENT MAY BE AN OFFENCE UNDER THE OFFICIAL SECRETS ACTS OF 1911-1989. (When released to persons outside Government service, this document is issued on a personal basis and the recipient to whom it may be entrusted in confidence, within the provision of the Official Secrets Acts 1911-1989, is personally responsible for its safe custody and for seeing that its contents are disclosed only to authorized persons).

**CARRIER, PERSONNEL, FULL TRACKED, FV 432 MK 2 AND 2/1**

**MODIFICATION INSTRUCTION NO. 1**

---

**SUBJECT: Fire fighting equipment**

**CANCELLATION**

**INTRODUCTION**

1 AESP 2350-T-251-811 Mod Instr No. 1, EMER E107/2 Mod Instr 49 is hereby cancelled. This modification was applicable to equipment that has been declared obsolete, and is therefore no longer required.

**ACTION**

- 2 Amend AESP 2350-T-251-811 Mod Instr 1, EMER E107/2 modification index accordingly.
- 3 File this Page 1/2 in place of Mod Instr No. 49 dated Apr 67, all pages of which are to be destroyed.

**CONDITIONS OF RELEASE**

- |   |   |   |   |
|---|---|---|---|
| 1 | This information is released by the UK Government for Defence purposes only.  | 3 | This information may be disclosed only within the Defence Department of the recipient Government, except as otherwise authorized by Ministry of Defence (Army). |
| 2 | This information must be afforded the same degree of protection as that afforded to information of an equivalent security marking originated by the recipient Government or as required by the recipient Government's security regulations. | 4 | This information may be subject to privately owned rights.  |

THIS DOCUMENT IS THE PROPERTY OF HER BRITANNIC MAJESTY'S GOVERNMENT, and is issued for the information of such persons only as need to know its contents in the course of their official duties. Any person finding this document should hand it to a British forces unit or to a police station for its safe return to the MINISTRY OF DEFENCE (Dsy (Pol)), MAIN BUILDING, WHITEHALL, LONDON SW1A 2HB with particulars of how and where found. THE UNAUTHORIZED RETENTION OR DESTRUCTION OF THIS DOCUMENT MAY BE AN OFFENCE UNDER THE OFFICIAL SECRETS ACTS OF 1911-1989. (When released to persons outside Government service, this document is issued on a personal basis and the recipient to whom it may be entrusted in confidence, within the provision of the Official Secrets Acts 1911-1989, is personally responsible for its safe custody and for seeing that its contents are disclosed only to authorized persons).

**CARRIER, PERSONNEL, FULL TRACKED, FV 432 MK 2 AND 2/1**

**MODIFICATION INSTRUCTION NO. 1**

---

**SUBJECT: Battery ventilation**

**CANCELLATION**

**INTRODUCTION**

1 AESP 2350-T-251-811 Mod Instr No. 1, EMER E107/2 Mod Instr 50 is hereby cancelled. The details of this modification have been incorporated into the build standard.

**ACTION**

- 2 Amend AESP 2350-T-251-811 Mod Instr 1, EMER E107/2 modification index accordingly.
- 3 File this Page 1/2 in place of Mod Instr No. 50 dated Apr 67, all pages of which are to be destroyed.



**CONDITIONS OF RELEASE**

- |   |   |
|---|---|
| 1 This information is released by the UK Government for Defence purposes only.  | 3 This information may be disclosed only within the Defence Department of the recipient Government, except as otherwise authorized by Ministry of Defence (Army). |
| 2 This information must be afforded the same degree of protection as that afforded to information of an equivalent security marking originated by the recipient Government or as required by the recipient Government's security regulations. | 4 This information may be subject to privately owned rights.  |

THIS DOCUMENT IS THE PROPERTY OF HER BRITANNIC MAJESTY'S GOVERNMENT, and is issued for the information of such persons only as need to know its contents in the course of their official duties. Any person finding this document should hand it to a British forces unit or to a police station for its safe return to the MINISTRY OF DEFENCE (Dsy (Pol)), MAIN BUILDING, WHITEHALL, LONDON SW1A 2HB with particulars of how and where found. THE UNAUTHORIZED RETENTION OR DESTRUCTION OF THIS DOCUMENT MAY BE AN OFFENCE UNDER THE OFFICIAL SECRETS ACTS OF 1911-1989. (When released to persons outside Government service, this document is issued on a personal basis and the recipient to whom it may be entrusted in confidence, within the provision of the Official Secrets Acts 1911-1989, is personally responsible for its safe custody and for seeing that its contents are disclosed only to authorized persons).

**CARRIER, PERSONNEL, FULL TRACKED, FV432 MK 2 AND 2/1  
MODIFICATION INSTRUCTION NO. 1 (EMER TV E107/2 Mod Instr No 51)**

**SUBJECT: Commander's seat**

**CANCELLATION**

**INTRODUCTION**

- 1 AESP 2350-T-251-811 Mod Instr No. 1, EMER TV E107 Mod Instr No.51 dated Apr 67 is hereby cancelled. The details of this modification have been incorporated into the build standard.

**ACTION**

- 2 Amend AESP 2350-T-251-811 Mod Instr No.1, EMER TV E107/2 modification index accordingly
- 3 File this Page 1/2 in place of Mod Instr No. 51 dated Apr 67, all pages of which are to be destroyed.

CONDITIONS OF RELEASE  
(Applicable to copies supplied with Ministry of Defence  
approval to Commonwealth and Foreign Governments)

1. This information is released by the United Kingdom Government to the recipient Government for Defence purposes only.
2. This information must be accorded the same degree of security protection as that accorded thereto by the United Kingdom Government.
3. This information may be disclosed only within the Defence Department of the recipient Government, except as otherwise authorized by the Ministry of Defence.
4. This information may be subject to privately owned rights.

CARRIER, PERSONNEL, FULL TRACKED, FV 432, MK 1, 1/1, 2 AND 2/1

TECHNICAL HANDBOOK - MODIFICATION INSTRUCTION

Note: These Pages 1-2, Issue 2, supersede Pages 1-2, Issue 1 dated 28 Jul 69. Item marked ● has been amended.

SUB-TITLE: Smoke discharger terminal box sealing

1. Introduction

To prevent water ingress, the existing 'U' section seal on box is to be replaced by a flat gasket.

2. Priority: Group 'B' (Mgmt N 097 refers).

3. Estimated time required: Embodiment: 1 man-hour

4. Item affected: LV8 ACR/2590-99-865-7420 Terminal box, electrical, on AD No 02EA01 to 17EA00 inclusive.

5. Action required by:-

a. Units and establishments holding equipment

(1) Demand stores required. Automatic issue will be made to BAOR units.

(2) On receipt of stores, request REME to modify equipment.

b. Units authorized to carry out unit, field or base repairs

When requested by units or during overhaul carry out this modification.

c. All recipients of this EMER

Add particulars to Tkd Veh E 107/2 Mod Instr Index.

6. Stores, tools and equipment:-

a. The following stores are to be demanded as a set, quoting registration number of the vehicle and this EMER as authority for the demand.

<u>VAOS Section</u>	<u>Part No</u>	<u>Designation</u>	<u>Qty per veh</u>
LV9/ACR	MOD 29411	Mod set: Smoke Discharger Terminal Box	1
Comprising:-			
Z2	FV 602944	Gasket	(2)
	5305-99-913-9155	Screw, BA, fillister hd, No 2 x 1/2 in.	(4)
LV6/MT1	5330-99-943-6848	Washer, seal, locking, 0.195 in. i.d. x 0.44 in. o.d. x 0.060 in. thick	(4)

b. Stores to be removed and reduced to produce

LV9/ACR	9320-99-865-7390	Channel, rubber, terminal box	2
		Screw, hex hd, BA, No 2 x 1/2 in. long	4

c. Stores to be modified

LV9/ACR	<del>2590</del> 99-865-7420 5940	Terminal box, electrical	2
	FV 499815		

7. Sequence of operations:-

- Remove and discard existing channel rubber seals from terminal box covers.
- Secure new seals to inside of cover, using adhesive H1 8040-99-220-2851.
- See Fig 1: Remove and discard two existing hexagon set screws and fit No 2 BA fillister head screws with seal washers (5330-99-943-6848) and original washers.
- Fit terminal box covers.

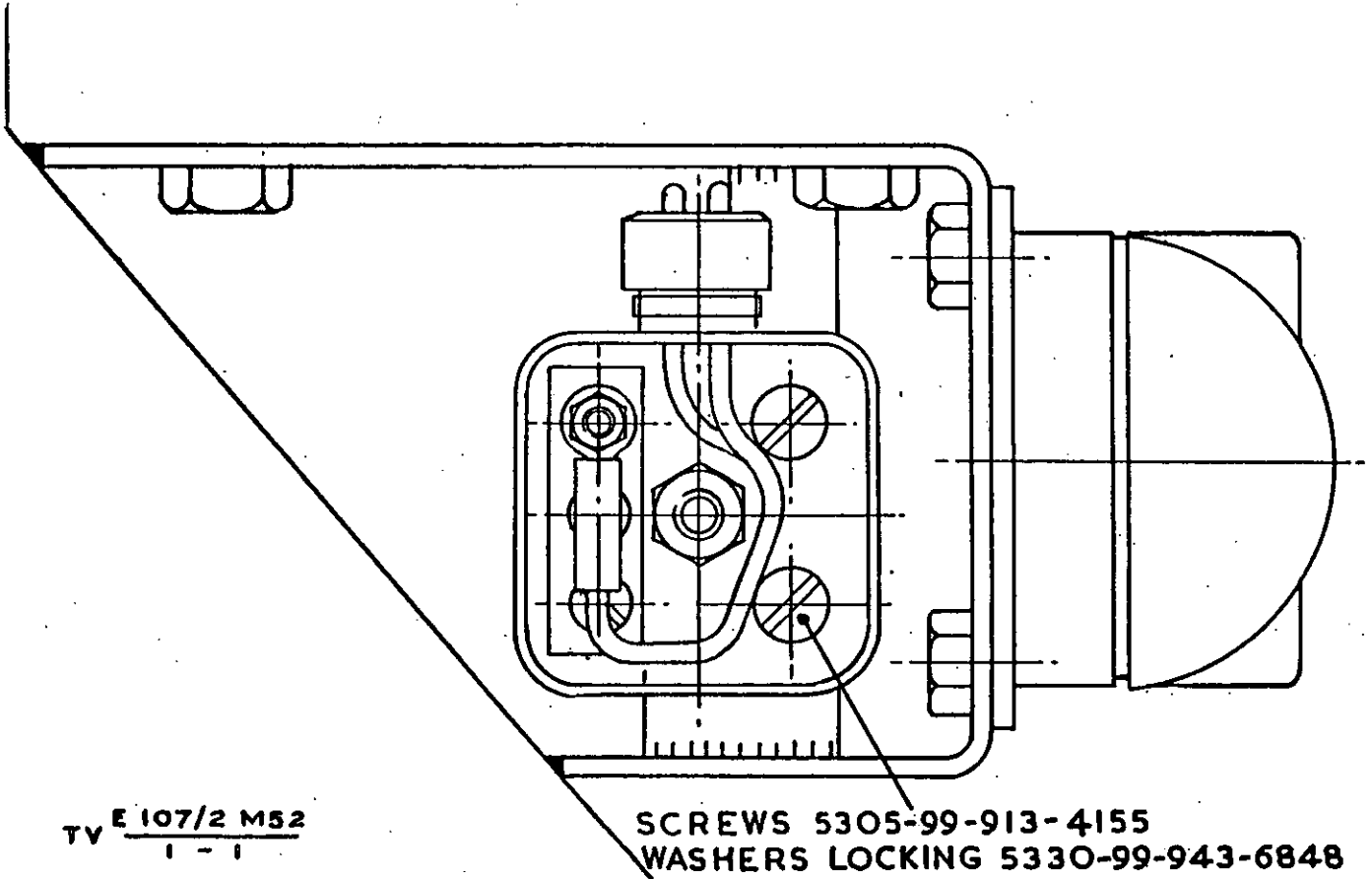

Fig 1 - Detail of box assembly

(Def and Mods) 706105  
FVRDE Approval 29411

END

CARRIER, PERSONNEL, FULL TRACKED, FV 432, MK 1 AND 2

TECHNICAL HANDBOOK - MODIFICATION INSTRUCTION

Note: These Pages 1-2, Issue 2, supersede Pages 1-2, Issue 1, dated 28 Jun 67. Para 6 and 7 have been amended.

SUB-TITLE: Coolant PRV drain tube

1. Introduction

To obviate fire risk from coolant glycol residue igniting on exhaust manifold a hose is to be fitted on the PRV to lead coolant away.

2. Priority: Group 'B' (Mgmt N 097 refers).

3. Estimated time required: Embodiment: 1/2 man-hour

4. Item affected: LV6/MT1 2930-99-800-7916 Valve relief, FV 494851

5. Action required by:-

a. Units and establishments holding equipment

(1) Enter EMER No, sub-title and Army Modification Code in equipment log book.

(2) Demand stores required.

(3) On receipt of stores, request REME to modify equipment.

b. Units authorized to carry out unit repairs

(1) When requested by units, carry out this modification.

(2) Record completion of modification in equipment log book against appropriate entry.

c. All recipients of this EMER

Add particulars to Tkd Veh E 107/2 Mod Instr Index.

6. Stores, tools and equipment:-

The following stores are to be demanded

<u>VAOS Section</u>	<u>Part No</u>	<u>Designation</u>	<u>Qty per veh</u>
LV6/MT6	4720-99-805-7811	Hose, rubber, coolant, 5/16 in. i.d. x 19/32 in o.d.	4 ft
LV6/MT1	4730-99-801-1055	Clip	3
LV6/MT1	30594	Tubing mild steel, bundylin, 5/16 in. o.d.	1.1/2 in.

7. Sequence of operations:-

a. Make up a 4 ft length of rubber hose using the 5/16 in. tubing (30594) and two clips (4730-99-801-1055).

b. See Fig 1 and 1a:-

Fit new length of hose (4720-99-805-7811) to coolant PRV and secure with remaining clip (4730-99-801-1055) in the position shown.

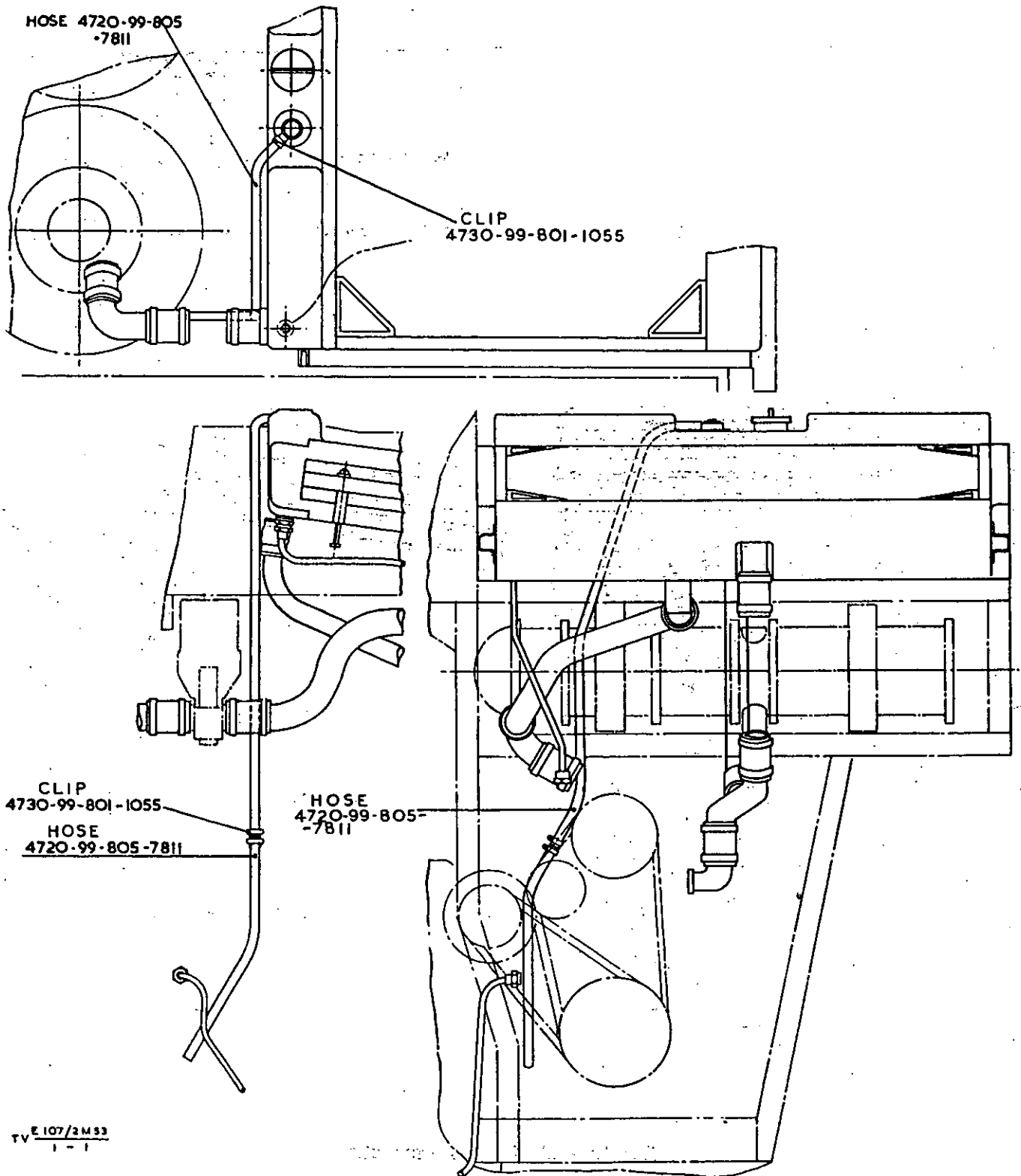

Fig 1 - B 81, hose routing

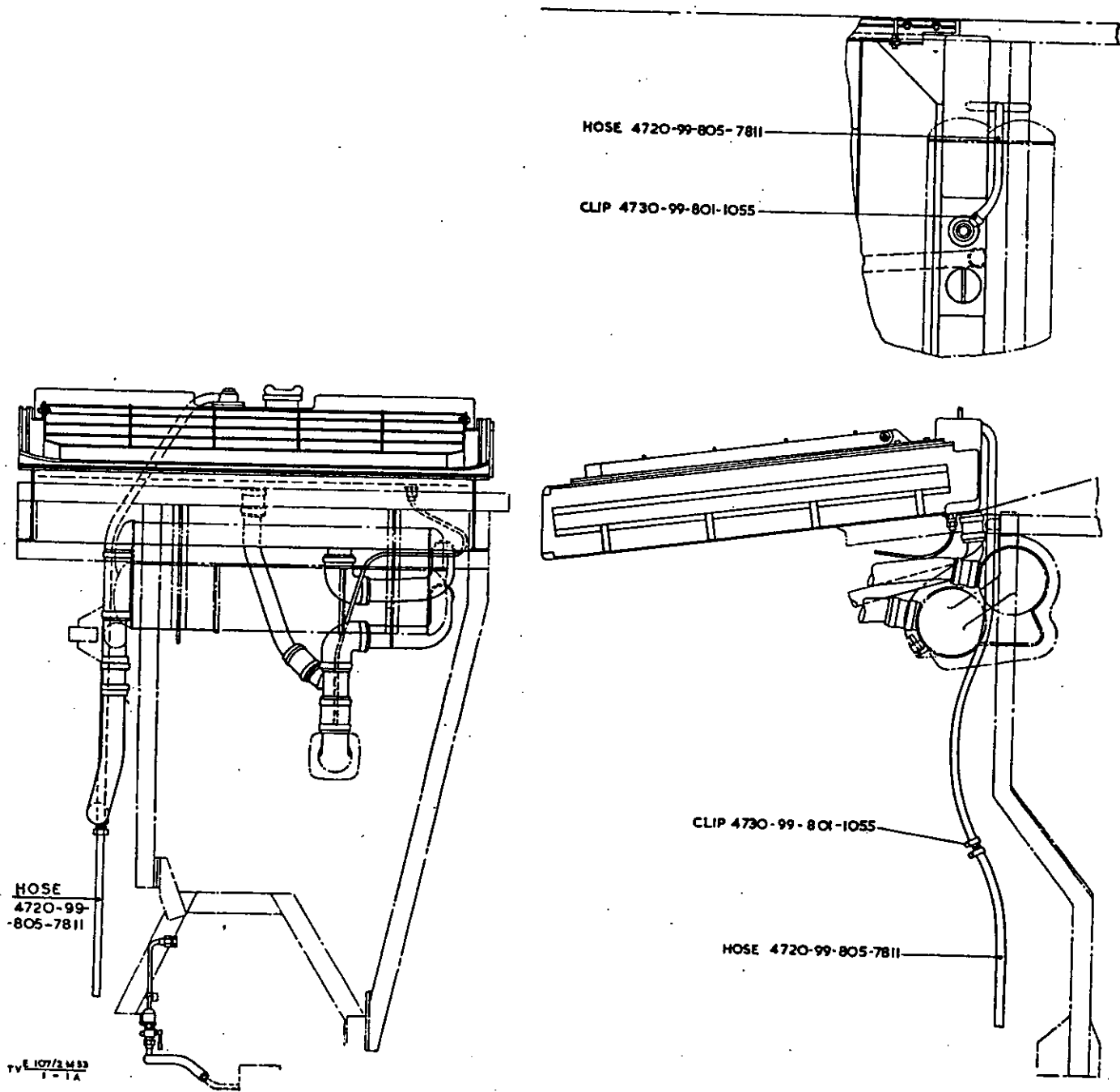

Fig 1a - K 60, hose routing

(Def and Mods) 706102  
FVRDE Approval 29353

END



CONDITIONS OF RELEASE

- |   |   |   |   |
|---|---|---|---|
| 1 | This information is released by the UK Government for Defence purposes only.  | 3 | This information may be disclosed only within the Defence Department of the recipient Government, except as otherwise authorized by Ministry of Defence (Army). |
| 2 | This information must be afforded the same degree of protection as that afforded to information of an equivalent security marking originated by the recipient Government or as required by the recipient Government's security regulations. | 4 | This information may be subject to privately owned rights.  |

THIS DOCUMENT IS THE PROPERTY OF HER BRITANNIC MAJESTY'S GOVERNMENT, and is issued for the information of such persons only as need to know its contents in the course of their official duties. Any person finding this document should hand it to a British forces unit or to a police station for its safe return to the MINISTRY OF DEFENCE (Dsy (Pol)), MAIN BUILDING, WHITEHALL, LONDON SW1A 2HB with particulars of how and where found. THE UNAUTHORIZED RETENTION OR DESTRUCTION OF THIS DOCUMENT MAY BE AN OFFENCE UNDER THE OFFICIAL SECRETS ACTS OF 1911-1989. (When released to persons outside Government service, this document is issued on a personal basis and the recipient to whom it may be entrusted in confidence, within the provision of the Official Secrets Acts 1911-1989, is personally responsible for its safe custody and for seeing that its contents are disclosed only to authorized persons).

**CARRIER, PERSONNEL, FULL TRACKED, FV 432 MK 2 AND 2/1**

**MODIFICATION INSTRUCTION NO. 1**

---

**SUBJECT: Wombat kit**

**CANCELLATION**

**INTRODUCTION**

1 AESP 2350-T-251-811 Mod Instr No. 1, EMER E107/2 Mod Instr 54 is hereby cancelled. This modification was applicable to equipment that has been declared obsolete, and is therefore no longer required.

**ACTION**

- 2 Amend AESP 2350-T-251-811 Mod Instr 1, EMER E107/2 modification index accordingly.
- 3 File this Page 1/2 in place of Mod Instr No. 54 dated Aug 67, all pages of which are to be destroyed.

**CONDITIONS OF RELEASE**

- |   |   |
|---|---|
| 1 This information is released by the UK Government for Defence purposes only.  | 3 This information may be disclosed only within the Defence Department of the recipient Government, except as otherwise authorized by Ministry of Defence (Army). |
| 2 This information must be afforded the same degree of protection as that afforded to information of an equivalent security marking originated by the recipient Government or as required by the recipient Government's security regulations. | 4 This information may be subject to privately owned rights.  |

THIS DOCUMENT IS THE PROPERTY OF HER BRITANNIC MAJESTY'S GOVERNMENT, and is issued for the information of such persons only as need to know its contents in the course of their official duties. Any person finding this document should hand it to a British forces unit or to a police station for its safe return to the MINISTRY OF DEFENCE (Dsy (Pol)), MAIN BUILDING, WHITEHALL, LONDON SW1A 2HB with particulars of how and where found. THE UNAUTHORIZED RETENTION OR DESTRUCTION OF THIS DOCUMENT MAY BE AN OFFENCE UNDER THE OFFICIAL SECRETS ACTS OF 1911-1989. (When released to persons outside Government service, this document is issued on a personal basis and the recipient to whom it may be entrusted in confidence, within the provision of the Official Secrets Acts 1911-1989, is personally responsible for its safe custody and for seeing that its contents are disclosed only to authorized persons).

**CARRIER, PERSONNEL, FULL TRACKED, FV432 MK 2 AND 2/1  
MODIFICATION INSTRUCTION NO. 1 (EMER TV E107/2 Mod Instr No 55)**

**SUBJECT: Fuel tank clamps**

**CANCELLATION**

**INTRODUCTION**

- 1 AESP 2350-T-251-811 Mod Instr No. 1; EMER TV E107 Mod Instr No.55 dated Oct 67 is hereby cancelled. The details of this modification have been incorporated into the build standard.

**ACTION**

- 2 Amend AESP 2350-T-251-811 Mod Instr No.1, EMER TV E107/2 modification index accordingly
- 3 File this Page 1/2 in place of Mod Instr No. 55 dated Oct 67, all pages of which are to be destroyed.

CONDITIONS OF RELEASE	
1 This information is released by the UK Government to the recipient Government for Defence purposes only	3 This information may be disclosed only within the Defence Department of the recipient Government, except as otherwise authorised by Ministry of Defence (Army)
2 This information must be accorded the same degree of security protection as that accorded thereto by the UK Government	4 This information may be subject to privately owned rights

THIS DOCUMENT IS THE PROPERTY OF HER BRITANNIC MAJESTY'S GOVERNMENT, and is issued for the information of such persons only as need to know its contents in the course of their official duties. Any person finding this document should hand it into a British forces unit or to a police station for its safe return to the MINISTRY OF DEFENCE 0. MOD Sy LONDON SW1A 2NB with particulars of how and where found. THE UNAUTHORISED RETENTION OR DESTRUCTION OF THE DOCUMENT IS AN OFFENCE UNDER THE OFFICIAL SECRETS ACTS OF 1911-1939. (When released to persons outside Government service, this document is issued on a personal basis and the recipient to whom it is entrusted in confidence, within the provisions of the Official Secrets Acts 1911-1939, is personally responsible for its safe custody and for seeing that its contents are disclosed only to authorised persons).

CARRIER, PERSONNEL, FULL TRACKED, MK 1, 1/1, 2 AND 2/1 (FV 432)

TECHNICAL HANDBOOK - MODIFICATION INSTRUCTION

Note: This Issue 2, supersedes Issue 1, Pages 1-2 dated Oct 67.

SUBJECT: BUOYANCY TRIMMER

(MVEE Approval 29361)

CANCELLATION

1. This modification instruction has been cancelled under the authority of 'A' Veh D&M Committee Approvals 31040/31041.
2. Scrap item and dispose of through normal channels.
3. Remove all copies of Issue 1, Pages 1-2 of this instruction and destroy.
4. Against subject reference in modification instruction index add 'Cancelled'.

END

70811 (215)  
Vehs & Wpns Br REME ALM/43000

**CONDITIONS OF RELEASE**

- |   |   |
|---|---|
| 1 This information is released by the UK Government for Defence purposes only.  | 3 This information may be disclosed only within the Defence Department of the recipient Government, except as otherwise authorized by Ministry of Defence (Army). |
| 2 This information must be afforded the same degree of protection as that afforded to information of an equivalent security marking originated by the recipient Government or as required by the recipient Government's security regulations. | 4 This information may be subject to privately owned rights.  |

THIS DOCUMENT IS THE PROPERTY OF HER BRITANNIC MAJESTY'S GOVERNMENT, and is issued for the information of such persons only as need to know its contents in the course of their official duties. Any person finding this document should hand it to a British forces unit or to a police station for its safe return to the MINISTRY OF DEFENCE (Dsy (Pol)), MAIN BUILDING, WHITEHALL, LONDON SW1A 2HB with particulars of how and where found. THE UNAUTHORIZED RETENTION OR DESTRUCTION OF THIS DOCUMENT MAY BE AN OFFENCE UNDER THE OFFICIAL SECRETS ACTS OF 1911-1989. (When released to persons outside Government service, this document is issued on a personal basis and the recipient to whom it may be entrusted in confidence, within the provision of the Official Secrets Acts 1911-1989, is personally responsible for its safe custody and for seeing that its contents are disclosed only to authorized persons).

**CARRIER, PERSONNEL, FULL TRACKED, FV432 MK 2 AND 2/1  
MODIFICATION INSTRUCTION NO. 1 (EMER TV E107/2 Mod Instr No 57)**

**SUBJECT: Power tool unit No.2, MK1.**

**CANCELLATION**

**INTRODUCTION**

- 1 AESP 2350-T-251-811 Mod Instr No. 1, EMER TV E107 Mod Instr No.57 dated Nov 67 is hereby cancelled. The details of this modification have been incorporated into the build standard.

**ACTION**

- 2 Amend AESP 2350-T-251-811 Mod Instr No.1, EMER TV E107/2 modification index accordingly
- 3 File this Page 1/2 in place of Mod Instr No. 57 dated Nov 67, all pages of which are to be destroyed.

CONDITIONS OF RELEASE

(To be applied to documents which the recipient Government may not release to anyone outside its Defence Departments).

- a. This information is released by the UK Government to the recipient Government for Defence purposes only.
- b. This information must be accorded the same degree of security protection as that accorded thereto by the UK Government.
- c. This information may be disclosed only within the Defence Departments of the recipient Government, except as otherwise authorized by Ministry of Defence (Army).
- d. This information may be subject to privately owned rights.

CARRIER, PERSONNEL, FULL TRACKED, FV 432, MK 1 AND 2

TECHNICAL HANDBOOK - MODIFICATION INSTRUCTION

Cancellation

1. This regulation referred to the provision of slots in the front panel of the flotation screen.
2. Approval 30756 introduces new production flotation screens, without vision panels, which are to be fitted to vehicles as replacement screens.
3. All copies of Issue 1, Pages 1-9, dated 20 Nov 67 are hereby cancelled, and are to be destroyed.
4. Delete all reference to 'Issue 1, Pages 1-9', from Tkd Veh A 001, Issue 18, Page 7.
5. Delete all reference to 'Issue 1, Flotation screen', from Tkd Veh E 107/2 Modification instruction index, Issue 4, Index Page 3, dated Mar 72.
6. When action as detailed in para 3, 4, and 5 has been completed, destroy this Issue 2.

E N D

**CONDITIONS OF RELEASE**

- |   |   |   |   |
|---|---|---|---|
| 1 | This information is released by the UK Government for Defence purposes only.  | 3 | This information may be disclosed only within the Defence Department of the recipient Government, except as otherwise authorized by Ministry of Defence (Army). |
| 2 | This information must be afforded the same degree of protection as that afforded to information of an equivalent security marking originated by the recipient Government or as required by the recipient Government's security regulations. | 4 | This information may be subject to privately owned rights.  |

THIS DOCUMENT IS THE PROPERTY OF HER BRITANNIC MAJESTY'S GOVERNMENT, and is issued for the information of such persons only as need to know its contents in the course of their official duties. Any person finding this document should hand it to a British forces unit or to a police station for its safe return to the MINISTRY OF DEFENCE (Dsy (Pol)), MAIN BUILDING, WHITEHALL, LONDON SW1A 2HB with particulars of how and where found. THE UNAUTHORIZED RETENTION OR DESTRUCTION OF THIS DOCUMENT MAY BE AN OFFENCE UNDER THE OFFICIAL SECRETS ACTS OF 1911-1989. (When released to persons outside Government service, this document is issued on a personal basis and the recipient to whom it may be entrusted in confidence, within the provision of the Official Secrets Acts 1911-1989, is personally responsible for its safe custody and for seeing that its contents are disclosed only to authorized persons).

**CARRIER, PERSONNEL, FULL TRACKED, FV432 MK 2 AND 2/1  
MODIFICATION INSTRUCTION NO. 1 (EMER TV E107/2 Mod Instr No 59)**

**SUBJECT: Exhaust silencer**

**CANCELLATION**

**INTRODUCTION**

- 1 AESP 2350-T-251-811 Mod Instr No. 1, EMER TV E107 Mod Instr No.59 dated Apr 68 is hereby cancelled. The details of this modification have been incorporated into the build standard.

**ACTION**

- 2 Amend AESP 2350-T-251-811 Mod Instr No.1, EMER TV E107/2 modification index accordingly
- 3 File this Page 1/2 in place of Mod Instr No. 59 dated Apr 68, all pages of which are to be destroyed.

**CONDITIONS OF RELEASE**

- |   |   |   |   |
|---|---|---|---|
| 1 | This information is released by the UK Government for Defence purposes only.  | 3 | This information may be disclosed only within the Defence Department of the recipient Government, except as otherwise authorized by Ministry of Defence (Army). |
| 2 | This information must be afforded the same degree of protection as that afforded to information of an equivalent security marking originated by the recipient Government or as required by the recipient Government's security regulations. | 4 | This information may be subject to privately owned rights.  |

THIS DOCUMENT IS THE PROPERTY OF HER BRITANNIC MAJESTY'S GOVERNMENT, and is issued for the information of such persons only as need to know its contents in the course of their official duties. Any person finding this document should hand it to a British forces unit or to a police station for its safe return to the MINISTRY OF DEFENCE (Dsy (Pol)), MAIN BUILDING, WHITEHALL, LONDON SW1A 2HB with particulars of how and where found. THE UNAUTHORIZED RETENTION OR DESTRUCTION OF THIS DOCUMENT MAY BE AN OFFENCE UNDER THE OFFICIAL SECRETS ACTS OF 1911-1989. (When released to persons outside Government service, this document is issued on a personal basis and the recipient to whom it may be entrusted in confidence, within the provision of the Official Secrets Acts 1911-1989, is personally responsible for its safe custody and for seeing that its contents are disclosed only to authorized persons).

**CARRIER, PERSONNEL, FULL TRACKED, FV432 MK 2 AND 2/1  
MODIFICATION INSTRUCTION NO. 1 (EMER TV E107/2 Mod Instr No 60)**

**SUBJECT: Access plate for governor dipstick**

**CANCELLATION**

**INTRODUCTION**

- 1 AESP 2350-T-251-811 Mod Instr No. 1, EMER TV E107 Mod Instr No.60 dated Jul 68 is hereby cancelled. The details of this modification have been incorporated into the build standard.

**ACTION**

- 2 Amend AESP 2350-T-251-811 Mod Instr No.1, EMER TV E107/2 modification index accordingly
- 3 File this Page 1/2 in place of Mod Instr No. 60 dated Jul 68, all pages of which are to be destroyed.

FOR OFFICIAL USE ONLY  
CROWN COPYRIGHT RESERVED

CARRIER, PERSONNEL, FULL TRACKED, FV 432, MK 2 and 2/1

TECHNICAL HANDBOOK - MODIFICATION INSTRUCTION

Cancellation

1. The information given in Issue 1, of this regulation is now cancelled.
2. All copies of Issue 1, Pages 1-4 are hereby cancelled and are to be destroyed.
3. This instruction is to be retained until the publication of an amended A001, when it is to be destroyed.

END



CONDITIONS OF RELEASE

- |   |   |   |   |
|---|---|---|---|
| 1 | This information is released by the UK Government for Defence purposes only.  | 3 | This information may be disclosed only within the Defence Department of the recipient Government, except as otherwise authorized by Ministry of Defence (Army). |
| 2 | This information must be afforded the same degree of protection as that afforded to information of an equivalent security marking originated by the recipient Government or as required by the recipient Government's security regulations. | 4 | This information may be subject to privately owned rights.  |

THIS DOCUMENT IS THE PROPERTY OF HER BRITANNIC MAJESTY'S GOVERNMENT, and is issued for the information of such persons only as need to know its contents in the course of their official duties. Any person finding this document should hand it to a British forces unit or to a police station for its safe return to the MINISTRY OF DEFENCE (Dsy (Pol)), MAIN BUILDING, WHITEHALL, LONDON SW1A 2HB with particulars of how and where found. THE UNAUTHORIZED RETENTION OR DESTRUCTION OF THIS DOCUMENT MAY BE AN OFFENCE UNDER THE OFFICIAL SECRETS ACTS OF 1911-1989. (When released to persons outside Government service, this document is issued on a personal basis and the recipient to whom it may be entrusted in confidence, within the provision of the Official Secrets Acts 1911-1989, is personally responsible for its safe custody and for seeing that its contents are disclosed only to authorized persons).

**CARRIER, PERSONNEL, FULL TRACKED, FV 432 MK 2 AND 2/1**

**MODIFICATION INSTRUCTION NO. 1**

---

**SUBJECT: Hydraulic system**

**CANCELLATION**

**INTRODUCTION**

1 AESP 2350-T-251-811 Mod Instr No. 1, EMER E107/2 Mod Instr 62 is hereby cancelled. This modification is applicable to Mk 1 vehicles only.

**ACTION**

- 2 Amend AESP 2350-T-251-811 Mod Instr 1, EMER E107/2 modification index accordingly.
- 3 File this Page 1/2 in place of Mod Instr No. 62 dated Jan 68, all pages of which are to be destroyed.

**CONDITIONS OF RELEASE**

- |   |   |   |   |
|---|---|---|---|
| 1 | This information is released by the UK Government for Defence purposes only.  | 3 | This information may be disclosed only within the Defence Department of the recipient Government, except as otherwise authorized by Ministry of Defence (Army). |
| 2 | This information must be afforded the same degree of protection as that afforded to information of an equivalent security marking originated by the recipient Government or as required by the recipient Government's security regulations. | 4 | This information may be subject to privately owned rights.  |

THIS DOCUMENT IS THE PROPERTY OF HER BRITANNIC MAJESTY'S GOVERNMENT, and is issued for the information of such persons only as need to know its contents in the course of their official duties. Any person finding this document should hand it to a British forces unit or to a police station for its safe return to the MINISTRY OF DEFENCE (Dsy (Pol)), MAIN BUILDING, WHITEHALL, LONDON SW1A 2HB with particulars of how and where found. THE UNAUTHORIZED RETENTION OR DESTRUCTION OF THIS DOCUMENT MAY BE AN OFFENCE UNDER THE OFFICIAL SECRETS ACTS OF 1911-1989. (When released to persons outside Government service, this document is issued on a personal basis and the recipient to whom it may be entrusted in confidence, within the provision of the Official Secrets Acts 1911-1989, is personally responsible for its safe custody and for seeing that its contents are disclosed only to authorized persons).

**CARRIER, PERSONNEL, FULL TRACKED, FV432 MK 2 AND 2/1  
MODIFICATION INSTRUCTION NO. 1 (EMER TV E107/2 Mod Instr No 63)**

**SUBJECT: Cupola periscope**

**CANCELLATION**

**INTRODUCTION**

- 1 AESP 2350-T-251-811 Mod Instr No. 1, EMER TV E107 Mod Instr No.63 dated Apr 68 is hereby cancelled. The details of this modification have been incorporated into the build standard.

**ACTION**

- 2 Amend AESP 2350-T-251-811 Mod Instr No.1, EMER TV E107/2 modification index accordingly
- 3 File this Page 1/2 in place of Mod Instr No. 63 dated Apr 68, all pages of which are to be destroyed.

**CONDITIONS OF RELEASE**

- |   |   |
|---|---|
| 1     This information is released by the UK Government for Defence purposes only.  | 3     This information may be disclosed only within the Defence Department of the recipient Government, except as otherwise authorized by Ministry of Defence (Army). |
| 2     This information must be afforded the same degree of protection as that afforded to information of an equivalent security marking originated by the recipient Government or as required by the recipient Government's security regulations. | 4     This information may be subject to privately owned rights.  |

THIS DOCUMENT IS THE PROPERTY OF HER BRITANNIC MAJESTY'S GOVERNMENT, and is issued for the information of such persons only as need to know its contents in the course of their official duties. Any person finding this document should hand it to a British forces unit or to a police station for its safe return to the MINISTRY OF DEFENCE (Dsy (Pol)), MAIN BUILDING, WHITEHALL, LONDON SW1A 2HB with particulars of how and where found. THE UNAUTHORIZED RETENTION OR DESTRUCTION OF THIS DOCUMENT MAY BE AN OFFENCE UNDER THE OFFICIAL SECRETS ACTS OF 1911-1989. (When released to persons outside Government service, this document is issued on a personal basis and the recipient to whom it may be entrusted in confidence, within the provision of the Official Secrets Acts 1911-1989, is personally responsible for its safe custody and for seeing that its contents are disclosed only to authorized persons).

**CARRIER, PERSONNEL, FULL TRACKED, FV 432 MK 2 AND 2/1**

**MODIFICATION INSTRUCTION NO. 1**

---

**SUBJECT: Fire detection equipment**

**CANCELLATION**

**INTRODUCTION**

1     AESP 2350-T-251-811 Mod Instr No. 1, EMER E107/2 Mod Instr 64 is hereby cancelled. This modification is applicable to Mk 1 vehicles only.

**ACTION**

- 2     Amend AESP 2350-T-251-811 Mod Instr 1, EMER E107/2 modification index accordingly.
- 3     File this Page 1/2 in place of Mod Instr No. 64 dated Apr 68, all pages of which are to be destroyed.

**CONDITIONS OF RELEASE**

- |   |   |   |   |
|---|---|---|---|
| 1 | This information is released by the UK Government for Defence purposes only.  | 3 | This information may be disclosed only within the Defence Department of the recipient Government, except as otherwise authorized by Ministry of Defence (Army). |
| 2 | This information must be afforded the same degree of protection as that afforded to information of an equivalent security marking originated by the recipient Government or as required by the recipient Government's security regulations. | 4 | This information may be subject to privately owned rights.  |

THIS DOCUMENT IS THE PROPERTY OF HER BRITANNIC MAJESTY'S GOVERNMENT, and is issued for the information of such persons only as need to know its contents in the course of their official duties. Any person finding this document should hand it to a British forces unit or to a police station for its safe return to the MINISTRY OF DEFENCE (Dsy (Pol)), MAIN BUILDING, WHITEHALL, LONDON SW1A 2HB with particulars of how and where found. THE UNAUTHORIZED RETENTION OR DESTRUCTION OF THIS DOCUMENT MAY BE AN OFFENCE UNDER THE OFFICIAL SECRETS ACTS OF 1911-1989. (When released to persons outside Government service, this document is issued on a personal basis and the recipient to whom it may be entrusted in confidence, within the provision of the Official Secrets Acts 1911-1989, is personally responsible for its safe custody and for seeing that its contents are disclosed only to authorized persons).

**CARRIER, PERSONNEL, FULL TRACKED, FV 432 MK 2 AND 2/1**

**MODIFICATION INSTRUCTION NO. 1**

---

**SUBJECT: Oil tank breather**

**CANCELLATION**

**INTRODUCTION**

1 AESP 2350-T-251-811 Mod Instr No. 1, EMER E107/2 Mod Instr 65 is hereby cancelled. This modification is applicable to Mk 1 vehicles only.

**ACTION**

- 2 Amend AESP 2350-T-251-811 Mod Instr 1, EMER E107/2 modification index accordingly.
- 3 File this Page 1/2 in place of Mod Instr No. 65 dated Oct 68, all pages of which are to be destroyed.

**CONDITIONS OF RELEASE**

- |   |   |
|---|---|
| 1 This information is released by the UK Government for Defence purposes only.  | 3 This information may be disclosed only within the Defence Department of the recipient Government, except as otherwise authorized by Ministry of Defence (Army). |
| 2 This information must be afforded the same degree of protection as that afforded to information of an equivalent security marking originated by the recipient Government or as required by the recipient Government's security regulations. | 4 This information may be subject to privately owned rights.  |

THIS DOCUMENT IS THE PROPERTY OF HER BRITANNIC MAJESTY'S GOVERNMENT, and is issued for the information of such persons only as need to know its contents in the course of their official duties. Any person finding this document should hand it to a British forces unit or to a police station for its safe return to the MINISTRY OF DEFENCE (Dsy (Pol)), MAIN BUILDING, WHITEHALL, LONDON SW1A 2HB with particulars of how and where found. THE UNAUTHORIZED RETENTION OR DESTRUCTION OF THIS DOCUMENT MAY BE AN OFFENCE UNDER THE OFFICIAL SECRETS ACTS OF 1911-1989. (When released to persons outside Government service, this document is issued on a personal basis and the recipient to whom it may be entrusted in confidence, within the provision of the Official Secrets Acts 1911-1989, is personally responsible for its safe custody and for seeing that its contents are disclosed only to authorized persons).

**CARRIER, PERSONNEL, FULL TRACKED, FV432 MK 2 AND 2/1  
MODIFICATION INSTRUCTION NO. 1 (EMER TV E107/2 Mod Instr No 66)**

**SUBJECT: Ventilation ducting**

**CANCELLATION**

**INTRODUCTION**

- 1 AESP 2350-T-251-811 Mod Instr No. 1, EMER TV E107 Mod Instr No.66 dated May 68 is hereby cancelled. The details of this modification have been incorporated into the build standard.

**ACTION**

- 2 Amend AESP 2350-T-251-811 Mod Instr No.1, EMER TV E107/2 modification index accordingly
- 3 File this Page 1/2 in place of Mod Instr No. 66 dated May 68, all pages of which are to be destroyed.

**CONDITIONS OF RELEASE**

- |   |   |   |   |
|---|---|---|---|
| 1 | This information is released by the UK Government for Defence purposes only.  | 3 | This information may be disclosed only within the Defence Department of the recipient Government, except as otherwise authorized by Ministry of Defence (Army). |
| 2 | This information must be afforded the same degree of protection as that afforded to information of an equivalent security marking originated by the recipient Government or as required by the recipient Government's security regulations. | 4 | This information may be subject to privately owned rights.  |

THIS DOCUMENT IS THE PROPERTY OF HER BRITANNIC MAJESTY'S GOVERNMENT, and is issued for the information of such persons only as need to know its contents in the course of their official duties. Any person finding this document should hand it to a British forces unit or to a police station for its safe return to the MINISTRY OF DEFENCE (Dsy (Pol)), MAIN BUILDING, WHITEHALL, LONDON SW1A 2HB with particulars of how and where found. THE UNAUTHORIZED RETENTION OR DESTRUCTION OF THIS DOCUMENT MAY BE AN OFFENCE UNDER THE OFFICIAL SECRETS ACTS OF 1911-1989. (When released to persons outside Government service, this document is issued on a personal basis and the recipient to whom it may be entrusted in confidence, within the provision of the Official Secrets Acts 1911-1989, is personally responsible for its safe custody and for seeing that its contents are disclosed only to authorized persons).

**CARRIER, PERSONNEL, FULL TRACKED, FV432 MK 2 AND 2/1  
MODIFICATION INSTRUCTION NO. 1 (EMER TV E107/2 Mod Instr No 67)**

**SUBJECT: Power pack identification plate**

**CANCELLATION**

**INTRODUCTION**

- 1 AESP 2350-T-251-811 Mod Instr No. 1, EMER TV E107 Mod Instr No.67 dated Dec 70 is hereby cancelled. The details of this modification have been incorporated into the build standard.

**ACTION**

- 2 Amend AESP 2350-T-251-811 Mod Instr No.1, EMER TV E107/2 modification index accordingly
- 3 File this Page 1/2 in place of Mod Instr No. 67 dated Dec 70, all pages of which are to be destroyed.

CONDITIONS OF RELEASE

- |   |   |   |   |
|---|---|---|---|
| 1 | This information is released by the UK Government for Defence purposes only.  | 3 | This information may be disclosed only within the Defence Department of the recipient Government, except as otherwise authorized by Ministry of Defence (Army). |
| 2 | This information must be afforded the same degree of protection as that afforded to information of an equivalent security marking originated by the recipient Government or as required by the recipient Government's security regulations. | 4 | This information may be subject to privately owned rights.  |

THIS DOCUMENT IS THE PROPERTY OF HER BRITANNIC MAJESTY'S GOVERNMENT, and is issued for the information of such persons only as need to know its contents in the course of their official duties. Any person finding this document should hand it to a British forces unit or to a police station for its safe return to the MINISTRY OF DEFENCE (Dsy (Pol)), MAIN BUILDING, WHITEHALL, LONDON SW1A 2HB with particulars of how and where found. THE UNAUTHORIZED RETENTION OR DESTRUCTION OF THIS DOCUMENT MAY BE AN OFFENCE UNDER THE OFFICIAL SECRETS ACTS OF 1911-1989. (When released to persons outside Government service, this document is issued on a personal basis and the recipient to whom it may be entrusted in confidence, within the provision of the Official Secrets Acts 1911-1989, is personally responsible for its safe custody and for seeing that its contents are disclosed only to authorized persons).

**CARRIER, PERSONNEL, FULL TRACKED, FV 432 MK 2 AND 2/1**

**MODIFICATION INSTRUCTION NO. 1**

---

**SUBJECT: Air inlet louvre**

**CANCELLATION**

**INTRODUCTION**

1 AESP 2350-T-251-811 Mod Instr No. 1, EMER E107/2 Mod Instr 68 is hereby cancelled. This modification was applicable to equipment that has been declared obsolete, and is therefore no longer required.

**ACTION**

- 2 Amend AESP 2350-T-251-811 Mod Instr 1, EMER E107/2 modification index accordingly.
- 3 File this Page 1/2 in place of Mod Instr No. 68 dated Jul 68, all pages of which are to be destroyed.

**CONDITIONS OF RELEASE**

- |   |   |   |   |
|---|---|---|---|
| 1 | This information is released by the UK Government for Defence purposes only.  | 3 | This information may be disclosed only within the Defence Department of the recipient Government, except as otherwise authorized by Ministry of Defence (Army). |
| 2 | This information must be afforded the same degree of protection as that afforded to information of an equivalent security marking originated by the recipient Government or as required by the recipient Government's security regulations. | 4 | This information may be subject to privately owned rights.  |

THIS DOCUMENT IS THE PROPERTY OF HER BRITANNIC MAJESTY'S GOVERNMENT, and is issued for the information of such persons only as need to know its contents in the course of their official duties. Any person finding this document should hand it to a British forces unit or to a police station for its safe return to the MINISTRY OF DEFENCE (Dsy (Pol)), MAIN BUILDING, WHITEHALL, LONDON SW1A 2HB with particulars of how and where found. THE UNAUTHORIZED RETENTION OR DESTRUCTION OF THIS DOCUMENT MAY BE AN OFFENCE UNDER THE OFFICIAL SECRETS ACTS OF 1911-1989. (When released to persons outside Government service, this document is issued on a personal basis and the recipient to whom it may be entrusted in confidence, within the provision of the Official Secrets Acts 1911-1989, is personally responsible for its safe custody and for seeing that its contents are disclosed only to authorized persons).

**CARRIER, PERSONNEL, FULL TRACKED, FV432 MK 2 AND 2/1  
MODIFICATION INSTRUCTION NO. 1 (EMER TV E107/2 Mod Instr No 69)**

**SUBJECT: Track pad and mud deflectors**

**CANCELLATION**

**INTRODUCTION**

- 1 AESP 2350-T-251-811 Mod Instr No. 1, EMER TV E107 Mod Instr No.69 dated Aug 68 is hereby cancelled. The details of this modification have been incorporated into the build standard.

**ACTION**

- 2 Amend AESP 2350-T-251-811 Mod Instr No.1, EMER TV E107/2 modification index accordingly
- 3 File this Page 1/2 in place of Mod Instr No. 69 dated Aug 68, all pages of which are to be destroyed.



CONDITIONS OF RELEASE

- |   |   |   |   |
|---|---|---|---|
| 1 | This information is released by the UK Government for Defence purposes only.  | 3 | This information may be disclosed only within the Defence Department of the recipient Government, except as otherwise authorized by Ministry of Defence (Army). |
| 2 | This information must be afforded the same degree of protection as that afforded to information of an equivalent security marking originated by the recipient Government or as required by the recipient Government's security regulations. | 4 | This information may be subject to privately owned rights.  |

THIS DOCUMENT IS THE PROPERTY OF HER BRITANNIC MAJESTY'S GOVERNMENT, and is issued for the information of such persons only as need to know its contents in the course of their official duties. Any person finding this document should hand it to a British forces unit or to a police station for its safe return to the MINISTRY OF DEFENCE (Dsy (Pol)), MAIN BUILDING, WHITEHALL, LONDON SW1A 2HB with particulars of how and where found. THE UNAUTHORIZED RETENTION OR DESTRUCTION OF THIS DOCUMENT MAY BE AN OFFENCE UNDER THE OFFICIAL SECRETS ACTS OF 1911-1989. (When released to persons outside Government service, this document is issued on a personal basis and the recipient to whom it may be entrusted in confidence, within the provision of the Official Secrets Acts 1911-1989, is personally responsible for its safe custody and for seeing that its contents are disclosed only to authorized persons).

**CARRIER, PERSONNEL, FULL TRACKED, FV 432 MK 2 AND 2/1**

**MODIFICATION INSTRUCTION NO. 1**

---

**SUBJECT: Carl Gustave kit**

**CANCELLATION**

**INTRODUCTION**

1 AESP 2350-T-251-811 Mod Instr No. 1, EMER E107/2 Mod Instr 70 is hereby cancelled. This modification was applicable to equipment that has been declared obsolete, and is therefore no longer required.

**ACTION**

- 2 Amend AESP 2350-T-251-811 Mod Instr 1, EMER E107/2 modification index accordingly.
- 3 File this Page 1/2 in place of Mod Instr No. 70 dated Jul 68, all pages of which are to be destroyed.

**CONDITIONS OF RELEASE**

- |   |   |   |   |
|---|---|---|---|
| 1 | This information is released by the UK Government for Defence purposes only.  | 3 | This information may be disclosed only within the Defence Department of the recipient Government, except as otherwise authorized by Ministry of Defence (Army). |
| 2 | This information must be afforded the same degree of protection as that afforded to information of an equivalent security marking originated by the recipient Government or as required by the recipient Government's security regulations. | 4 | This information may be subject to privately owned rights.  |

THIS DOCUMENT IS THE PROPERTY OF HER BRITANNIC MAJESTY'S GOVERNMENT, and is issued for the information of such persons only as need to know its contents in the course of their official duties. Any person finding this document should hand it to a British forces unit or to a police station for its safe return to the MINISTRY OF DEFENCE (Dsy (Pol)), MAIN BUILDING, WHITEHALL, LONDON SW1A 2HB with particulars of how and where found. THE UNAUTHORIZED RETENTION OR DESTRUCTION OF THIS DOCUMENT MAY BE AN OFFENCE UNDER THE OFFICIAL SECRETS ACTS OF 1911-1989. (When released to persons outside Government service, this document is issued on a personal basis and the recipient to whom it may be entrusted in confidence, within the provision of the Official Secrets Acts 1911-1989, is personally responsible for its safe custody and for seeing that its contents are disclosed only to authorized persons).

**CARRIER, PERSONNEL, FULL TRACKED, FV432 MK 2 AND 2/1  
MODIFICATION INSTRUCTION NO. 1 (EMER TV E107/2 Mod Instr No 71)**

**SUBJECT: Painting of ventilation ducting**

**CANCELLATION**

**INTRODUCTION**

- 1 AESP 2350-T-251-811 Mod Instr No. 1, EMER TV E107 Mod Instr No.71 dated Aug 68 is hereby cancelled. The details of this modification have been incorporated into the build standard.

**ACTION**

- 2 Amend AESP 2350-T-251-811 Mod Instr No.1, EMER TV E107/2 modification index accordingly
- 3 File this Page 1/2 in place of Mod Instr No. 71 dated Aug 71, all pages of which are to be destroyed.

CONDITIONS OF RELEASE

- |   |   |   |   |
|---|---|---|---|
| 1 | This information is released by the UK Government for Defence purposes only.  | 3 | This information may be disclosed only within the Defence Department of the recipient Government, except as otherwise authorized by Ministry of Defence (Army). |
| 2 | This information must be afforded the same degree of protection as that afforded to information of an equivalent security marking originated by the recipient Government or as required by the recipient Government's security regulations. | 4 | This information may be subject to privately owned rights.  |

THIS DOCUMENT IS THE PROPERTY OF HER BRITANNIC MAJESTY'S GOVERNMENT, and is issued for the information of such persons only as need to know its contents in the course of their official duties. Any person finding this document should hand it to a British forces unit or to a police station for its safe return to the MINISTRY OF DEFENCE (Dsy (Pol)), MAIN BUILDING, WHITEHALL, LONDON SW1A 2HB with particulars of how and where found. THE UNAUTHORIZED RETENTION OR DESTRUCTION OF THIS DOCUMENT MAY BE AN OFFENCE UNDER THE OFFICIAL SECRETS ACTS OF 1911-1989. (When released to persons outside Government service, this document is issued on a personal basis and the recipient to whom it may be entrusted in confidence, within the provision of the Official Secrets Acts 1911-1989, is personally responsible for its safe custody and for seeing that its contents are disclosed only to authorized persons).

**CARRIER, PERSONNEL, FULL TRACKED, FV 432 MK 2 AND 2/1**

**MODIFICATION INSTRUCTION NO. 1**

---

**SUBJECT: Accessories control box**

**CANCELLATION**

**INTRODUCTION**

1 AESP 2350-T-251-811 Mod Instr No. 1, EMER E107/2 Mod Instr 72 is hereby cancelled. The details of this modification have been incorporated into the build standard.

**ACTION**

- 2 Amend AESP 2350-T-251-811 Mod Instr 1, EMER E107/2 modification index accordingly.
- 3 File this Page 1/2 in place of Mod Instr No. 72 dated Aug 68, all pages of which are to be destroyed.

CONDITIONS OF RELEASE

- |   |   |   |   |
|---|---|---|---|
| 1 | This information is released by the UK Government for Defence purposes only.  | 3 | This information may be disclosed only within the Defence Department of the recipient Government, except as otherwise authorized by Ministry of Defence (Army). |
| 2 | This information must be afforded the same degree of protection as that afforded to information of an equivalent security marking originated by the recipient Government or as required by the recipient Government's security regulations. | 4 | This information may be subject to privately owned rights.  |

THIS DOCUMENT IS THE PROPERTY OF HER BRITANNIC MAJESTY'S GOVERNMENT, and is issued for the information of such persons only as need to know its contents in the course of their official duties. Any person finding this document should hand it to a British forces unit or to a police station for its safe return to the MINISTRY OF DEFENCE (Dsy (Pol)), MAIN BUILDING, WHITEHALL, LONDON SW1A 2HB with particulars of how and where found. THE UNAUTHORIZED RETENTION OR DESTRUCTION OF THIS DOCUMENT MAY BE AN OFFENCE UNDER THE OFFICIAL SECRETS ACTS OF 1911-1989. (When released to persons outside Government service, this document is issued on a personal basis and the recipient to whom it may be entrusted in confidence, within the provision of the Official Secrets Acts 1911-1989, is personally responsible for its safe custody and for seeing that its contents are disclosed only to authorized persons).

**CARRIER, PERSONNEL, FULL TRACKED, FV 432 MK 2 AND 2/1**

**MODIFICATION INSTRUCTION NO. 1**

---

**SUBJECT: Hull, rear door**

**CANCELLATION**

**INTRODUCTION**

1 AESP 2350-T-251-811 Mod Instr No. 1, EMER E107/2 Mod Instr 73 is hereby cancelled. The details of this modification have been incorporated into the build standard.

**ACTION**

- 2 Amend AESP 2350-T-251-811 Mod Instr 1, EMER E107/2 modification index accordingly.
- 3 File this Page 1/2 in place of Mod Instr No. 73 dated Mar 69, all pages of which are to be destroyed.

**CONDITIONS OF RELEASE**

- |   |   |
|---|---|
| 1 This information is released by the UK Government for Defence purposes only.  | 3 This information may be disclosed only within the Defence Department of the recipient Government, except as otherwise authorized by Ministry of Defence (Army). |
| 2 This information must be afforded the same degree of protection as that afforded to information of an equivalent security marking originated by the recipient Government or as required by the recipient Government's security regulations. | 4 This information may be subject to privately owned rights.  |

THIS DOCUMENT IS THE PROPERTY OF HER BRITANNIC MAJESTY'S GOVERNMENT, and is issued for the information of such persons only as need to know its contents in the course of their official duties. Any person finding this document should hand it to a British forces unit or to a police station for its safe return to the MINISTRY OF DEFENCE (Dsy (Pol)), MAIN BUILDING, WHITEHALL, LONDON SW1A 2HB with particulars of how and where found. THE UNAUTHORIZED RETENTION OR DESTRUCTION OF THIS DOCUMENT MAY BE AN OFFENCE UNDER THE OFFICIAL SECRETS ACTS OF 1911-1989. (When released to persons outside Government service, this document is issued on a personal basis and the recipient to whom it may be entrusted in confidence, within the provision of the Official Secrets Acts 1911-1989, is personally responsible for its safe custody and for seeing that its contents are disclosed only to authorized persons).

**CARRIER, PERSONNEL, FULL TRACKED, FV 432 MK 2 AND 2/1**

**MODIFICATION INSTRUCTION NO. 1**

---

**SUBJECT: Strengthened power pack frame**

**CANCELLATION**

**INTRODUCTION**

1 AESP 2350-T-251-811 Mod Instr No. 1, EMER E107/2 Mod Instr 75 is hereby cancelled. This modification is applicable to Mk 1 vehicles only.

**ACTION**

- 2 Amend AESP 2350-T-251-811 Mod Instr 1, EMER E107/2 modification index accordingly.
- 3 File this Page 1/2 in place of Mod Instr No. 75 dated Jun 69, all pages of which are to be destroyed.

**CONDITIONS OF RELEASE**

- |   |   |   |   |
|---|---|---|---|
| 1 | This information is released by the UK Government for Defence purposes only.  | 3 | This information may be disclosed only within the Defence Department of the recipient Government, except as otherwise authorized by Ministry of Defence (Army). |
| 2 | This information must be afforded the same degree of protection as that afforded to information of an equivalent security marking originated by the recipient Government or as required by the recipient Government's security regulations. | 4 | This information may be subject to privately owned rights.  |

THIS DOCUMENT IS THE PROPERTY OF HER BRITANNIC MAJESTY'S GOVERNMENT, and is issued for the information of such persons only as need to know its contents in the course of their official duties. Any person finding this document should hand it to a British forces unit or to a police station for its safe return to the MINISTRY OF DEFENCE (Dsy (Pol)), MAIN BUILDING, WHITEHALL, LONDON SW1A 2HB with particulars of how and where found. THE UNAUTHORIZED RETENTION OR DESTRUCTION OF THIS DOCUMENT MAY BE AN OFFENCE UNDER THE OFFICIAL SECRETS ACTS OF 1911-1989. (When released to persons outside Government service, this document is issued on a personal basis and the recipient to whom it may be entrusted in confidence, within the provision of the Official Secrets Acts 1911-1989, is personally responsible for its safe custody and for seeing that its contents are disclosed only to authorized persons).

**CARRIER, PERSONNEL, FULL TRACKED, FV432 MK 2 AND 2/1  
MODIFICATION INSTRUCTION NO. 1 (EMER TV E107/2 Mod Instr No 76)**

**SUBJECT: Power pack**

**CANCELLATION**

**INTRODUCTION**

- 1 AESP 2350-T-251-811 Mod Instr No. 1, EMER TV E107 Mod Instr No.76 dated Jul 69 is hereby cancelled. The details of this modification have been incorporated into the build standard.

**ACTION**

- 2 Amend AESP 2350-T-251-811 Mod Instr No.1, EMER TV E107/2 modification index accordingly
- 3 File this Page 1/2 in place of Mod Instr No. 76 dated Jul 69, all pages of which are to be destroyed.

**CONDITIONS OF RELEASE**

- |   |   |   |   |
|---|---|---|---|
| 1 | This information is released by the UK Government for Defence purposes only.  | 3 | This information may be disclosed only within the Defence Department of the recipient Government, except as otherwise authorized by Ministry of Defence (Army). |
| 2 | This information must be afforded the same degree of protection as that afforded to information of an equivalent security marking originated by the recipient Government or as required by the recipient Government's security regulations. | 4 | This information may be subject to privately owned rights.  |

THIS DOCUMENT IS THE PROPERTY OF HER BRITANNIC MAJESTY'S GOVERNMENT, and is issued for the information of such persons only as need to know its contents in the course of their official duties. Any person finding this document should hand it to a British forces unit or to a police station for its safe return to the MINISTRY OF DEFENCE (Dsy (Pol)), MAIN BUILDING, WHITEHALL, LONDON SW1A 2HB with particulars of how and where found. THE UNAUTHORIZED RETENTION OR DESTRUCTION OF THIS DOCUMENT MAY BE AN OFFENCE UNDER THE OFFICIAL SECRETS ACTS OF 1911-1989. (When released to persons outside Government service, this document is issued on a personal basis and the recipient to whom it may be entrusted in confidence, within the provision of the Official Secrets Acts 1911-1989, is personally responsible for its safe custody and for seeing that its contents are disclosed only to authorized persons).

**CARRIER, PERSONNEL, FULL TRACKED, FV432 MK 2 AND 2/1  
MODIFICATION INSTRUCTION NO. 1 (EMER TV E107/2 Mod Instr No 77)**

**SUBJECT: Strengthened power pack frame**

**CANCELLATION**

**INTRODUCTION**

- 1 AESP 2350-T-251-811 Mod Instr No. 1, EMER TV E107 Mod Instr No.77 dated Jun 69 is hereby cancelled. The details of this modification have been incorporated into the build standard.

**ACTION**

- 2 Amend AESP 2350-T-251-811 Mod Instr No.1, EMER TV E107/2 modification index accordingly
- 3 File this Page 1/2 in place of Mod Instr No. 77 dated Jun 69, all pages of which are to be destroyed.

**CONDITIONS OF RELEASE**

- |   |   |
|---|---|
| 1 This information is released by the UK Government for Defence purposes only.  | 3 This information may be disclosed only within the Defence Department of the recipient Government, except as otherwise authorized by Ministry of Defence (Army). |
| 2 This information must be afforded the same degree of protection as that afforded to information of an equivalent security marking originated by the recipient Government or as required by the recipient Government's security regulations. | 4 This information may be subject to privately owned rights.  |

THIS DOCUMENT IS THE PROPERTY OF HER BRITANNIC MAJESTY'S GOVERNMENT, and is issued for the information of such persons only as need to know its contents in the course of their official duties. Any person finding this document should hand it to a British forces unit or to a police station for its safe return to the MINISTRY OF DEFENCE (Dsy (Pol)), MAIN BUILDING, WHITEHALL, LONDON SW1A 2HB with particulars of how and where found. THE UNAUTHORIZED RETENTION OR DESTRUCTION OF THIS DOCUMENT MAY BE AN OFFENCE UNDER THE OFFICIAL SECRETS ACTS OF 1911-1989. (When released to persons outside Government service, this document is issued on a personal basis and the recipient to whom it may be entrusted in confidence, within the provision of the Official Secrets Acts 1911-1989, is personally responsible for its safe custody and for seeing that its contents are disclosed only to authorized persons).

**CARRIER, PERSONNEL, FULL TRACKED, FV432 MK 2 AND 2/1  
MODIFICATION INSTRUCTION NO. 1 (EMER TV E107/2 Mod Instr No 78)**

**SUBJECT: Auxiliary charging panel**

**CANCELLATION**

**INTRODUCTION**

- 1 AESP 2350-T-251-811 Mod Instr No. 1, EMER TV E107 Mod Instr No.78 dated Jun 70 is hereby cancelled. The details of this modification have been incorporated into the build standard.

**ACTION**

- 2 Amend AESP 2350-T-251-811 Mod Instr No.1, EMER TV E107/2 modification index accordingly
- 3 File this Page 1/2 in place of Mod Instr No. 78 dated Jun 70, all pages of which are to be destroyed.



CARRIER, PERSONNEL, FULL TRACKED, FV 432, MK 1, 1/1, 2, AND 2/1  
(0040.0110, 0040.0113, 0040.0111, 0040.0112)

TECHNICAL HANDBOOK - MODIFICATION INSTRUCTION

SUB-TITLE: Ventilation equipment, pressure/suction gauge filter

1. Introduction

To prevent water collecting in pressure gauge a Norgren type filter will be fitted to gauge atmosphere line.

2. Priority: Group 'B' (Mgmt N 097 refers).

3. Estimated time required

Embodiment: 1.1/2 man-hours.

4. Item affected: Ventilation equipment pressure gauge. It will be required on all Mk 1, 1/1 and Mk 2 vehicles, and on the following Mk 2/1 vehicles:-

10EA81-99, 11EA00-99, 12EA00-99, 13EA00-99, 14EA00-99,  
15EA00-99, 16EA00-99, 17EA00-99, 18EA00, 03ED42-73

5. Action required by:-

a. Units and establishments holding equipment

(1) Enter EMER No, sub-title and Army Modification Code in equipment log-book.

(2) Demand stores required. Automatic issue will be made to BAOR units.

(3) On receipt of stores, request REME to modify equipment.

b. Units authorized to carry out unit, field or base repairs

(1) When requested by units or during repairs or overhaul, carry out this modification.

(2) Record completion of modification in equipment log-book against appropriate entry.

c. All recipients of this EMER

Add particulars to Tkd Veh E 107/2 Mod Instr Index.

6. Stores, tools and equipment:-

a. The following stores are to be demanded as a set, see para 5.a.(2), quoting on the indent the registration number of the vehicle concerned and this EMER as authority for demand.

<u>VAOS</u> <u>Section</u>	<u>Part No</u>	<u>Designation</u>	<u>Qty</u> <u>per veh</u>
LV9/ACR	MOD 29395	Mod set: Ventilation equipment comprising:-	1
LV9/ACR	2540-99-804-2206 (FV 602997)	Bracket, double angle steel 1.1/2 in. x 2.7/16 in. x 1 in. legs	(1)
LV9/ACR	2540-99-804-2207 (FV 602996)	Bracket; angle steel painted 90 deg angle 2.7/16 in. legs 1.1/4 in. and 1.1/2 in.	(1)
LV6/MT1	4330-99-804-3651 (FV 564342)	Filter, fluid vacuum water trap Norgren type 30 AM-2 (GA Norgren Ltd)	(1)
LV9/ACR	4730-99-804-2208 (FV 602999)	Adapter, straight pipe steel cad plated 1/4 in. BSP x 3/8 in. UNF double end male x 1/4 in. long	(2)
LV9/ACR	2590-99-804-4819 (FV 602994)	Pipe, water trap	(2)
LV6/MT1	4730-99-801-1564	Nut, union pipe 3/8 in. 24 UNF 3/16 in. pipe	(2)
G1	5310-99-941-0904	Nut, precision, UNF 'P' steel 3/8 in. lock	(2)
G1	5310-99-944-0550	Washer, lock 3/8 in.	(2)
LV6/MT6	4720-99-805-8383	Tubing, rubber, 1/8 in. i.d. x 1/4 in. o.d. (11 in.)	(2)
Z2ZB	11022	Bolt, bright steel hex hd BA No 2 x 3/4 in. rust proof	(2)

b. Additional stores to be demanded for Mk 2/1 vehicles fitted with 5 in. fan.

<u>VAOS</u> <u>Section</u>	<u>Part No</u>	<u>Designation</u>	<u>Qty</u> <u>per veh</u>
LV9/ACR	2930-99-866-9213 (FV 538246)	Bracket, mounting ventilation fan controller	1
G1	5305-99-941-0279	Bolt, precision UNF-2A 'R' steel hex hd zinc coated 1/4 in. x 7/8 in.	2
G1	5310-99-941-0924	Nut, precision UNF 'P' steel hex 1/4 in. zinc coated	2
G1	5310-99-944-0548	Washer, lock 1/4 in.	2

Sequence of operations:-

a. See Fig 1:-

(1) Assemble water trap as shown and secure to rear of fan controller unit by using 2 BA x 3/4 in. long bolts with existing nuts and washers. Discard existing bolts.

(2) Disconnect existing flexible tubing between gauge and atmosphere at gauge end. Cut tube approximately in half enabling upper half to be reconnected to filter and lower half between filter and gauge. Spare tubing is supplied where connection cannot be made.

b. Mk 2/1 vehicles fitted with 5 in. fan: Secure fan controller bracket to bulkhead using  $\frac{1}{4}$  in. x  $\frac{7}{8}$  in. UNF bolts, nuts and lockwashers, in a similar mounting position to adjacent installations.

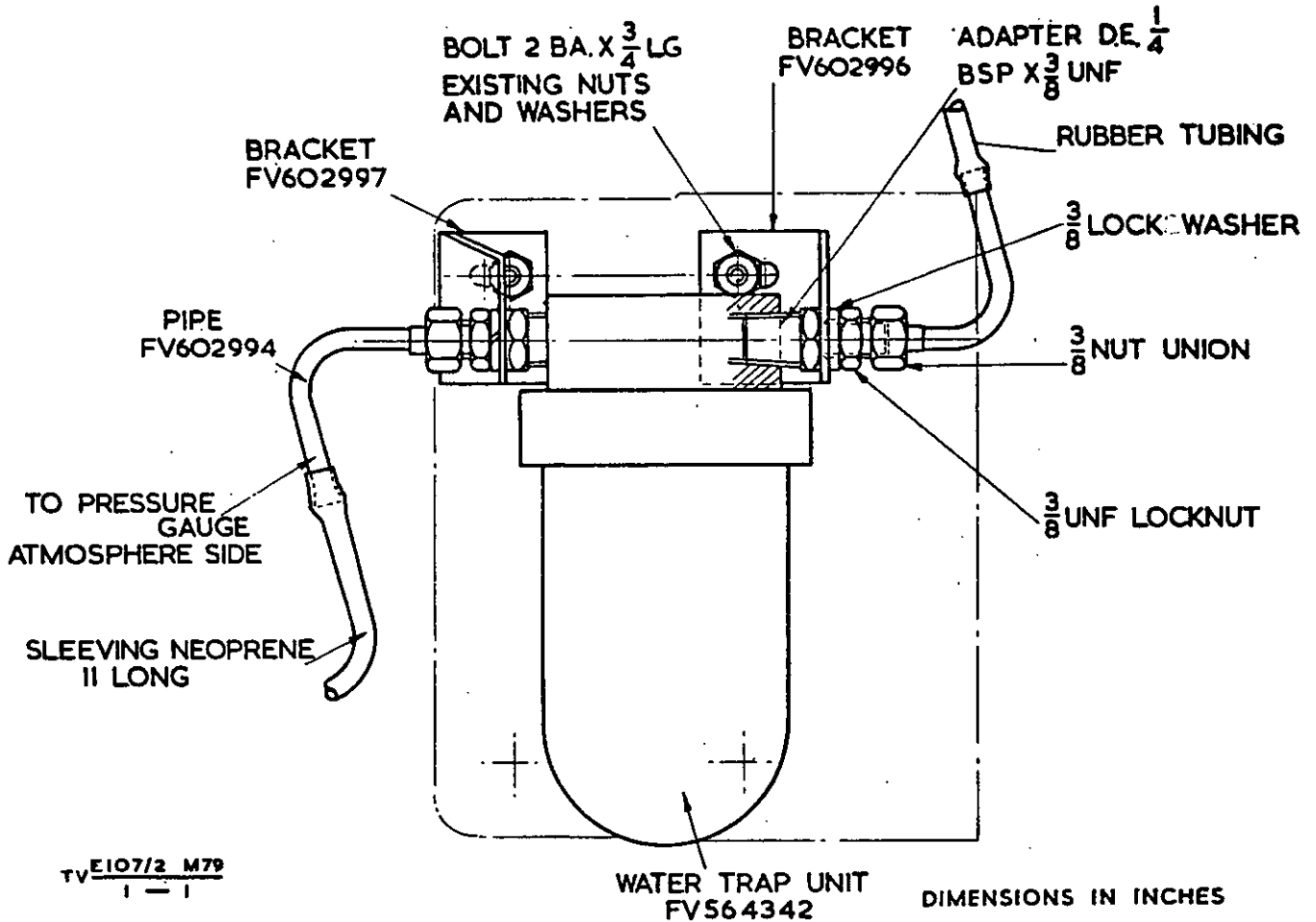

Fig 1 - Water trap assembly

Def and Mods 706101  
FVRDE Approval 29395

END

CONDITIONS OF RELEASE

- |   |   |   |   |
|---|---|---|---|
| 1 | This information is released by the UK Government for Defence purposes only.  | 3 | This information may be disclosed only within the Defence Department of the recipient Government, except as otherwise authorized by Ministry of Defence (Army). |
| 2 | This information must be afforded the same degree of protection as that afforded to information of an equivalent security marking originated by the recipient Government or as required by the recipient Government's security regulations. | 4 | This information may be subject to privately owned rights.  |

THIS DOCUMENT IS THE PROPERTY OF HER BRITANNIC MAJESTY'S GOVERNMENT, and is issued for the information of such persons only as need to know its contents in the course of their official duties. Any person finding this document should hand it to a British forces unit or to a police station for its safe return to the MINISTRY OF DEFENCE (Dsy (Pol)), MAIN BUILDING, WHITEHALL, LONDON SW1A 2HB with particulars of how and where found. THE UNAUTHORIZED RETENTION OR DESTRUCTION OF THIS DOCUMENT MAY BE AN OFFENCE UNDER THE OFFICIAL SECRETS ACTS OF 1911-1989. (When released to persons outside Government service, this document is issued on a personal basis and the recipient to whom it may be entrusted in confidence, within the provision of the Official Secrets Acts 1911-1989, is personally responsible for its safe custody and for seeing that its contents are disclosed only to authorized persons).

**CARRIER, PERSONNEL, FULL TRACKED, FV 432 MK 2 AND 2/1**

**MODIFICATION INSTRUCTION NO. 1**

---

**SUBJECT: CBR ventilation**

**CANCELLATION**

**INTRODUCTION**

1 AESP 2350-T-251-811 Mod Instr No. 1, EMER E107/2 Mod Instr 80 is hereby cancelled. The details of this modification have been incorporated into the build standard.

**ACTION**

- 2 Amend AESP 2350-T-251-811 Mod Instr 1, EMER E107/2 modification index accordingly.
- 3 File this Page 1/2 in place of Mod Instr No. 80 dated May 69, all pages of which are to be destroyed.

**CONDITIONS OF RELEASE**

- |   |   |   |   |
|---|---|---|---|
| 1 | This information is released by the UK Government for Defence purposes only.  | 3 | This information may be disclosed only within the Defence Department of the recipient Government, except as otherwise authorized by Ministry of Defence (Army). |
| 2 | This information must be afforded the same degree of protection as that afforded to information of an equivalent security marking originated by the recipient Government or as required by the recipient Government's security regulations. | 4 | This information may be subject to privately owned rights.  |

THIS DOCUMENT IS THE PROPERTY OF HER BRITANNIC MAJESTY'S GOVERNMENT, and is issued for the information of such persons only as need to know its contents in the course of their official duties. Any person finding this document should hand it to a British forces unit or to a police station for its safe return to the MINISTRY OF DEFENCE (Dsy (Pol)), MAIN BUILDING, WHITEHALL, LONDON SW1A 2HB with particulars of how and where found. THE UNAUTHORIZED RETENTION OR DESTRUCTION OF THIS DOCUMENT MAY BE AN OFFENCE UNDER THE OFFICIAL SECRETS ACTS OF 1911-1989. (When released to persons outside Government service, this document is issued on a personal basis and the recipient to whom it may be entrusted in confidence, within the provision of the Official Secrets Acts 1911-1989, is personally responsible for its safe custody and for seeing that its contents are disclosed only to authorized persons).

**CARRIER, PERSONNEL, FULL TRACKED, FV432 MK 2 AND 2/1  
MODIFICATION INSTRUCTION NO. 1 (EMER TV E107/2 Mod Instr No 81)**

**SUBJECT: Fuel tap access cover, locating clips**

**CANCELLATION**

**INTRODUCTION**

- 1 AESP 2350-T-251-811 Mod Instr No. 1, EMER TV E107 Mod Instr No.81 dated Oct 69 is hereby cancelled. The details of this modification have been incorporated into the build standard.

**ACTION**

- 2 Amend AESP 2350-T-251-811 Mod Instr No.1, EMER TV E107/2 modification index accordingly
- 3 File this Page 1/2 in place of Mod Instr No. 81 dated Oct 69, all pages of which are to be destroyed.

CONDITIONS OF RELEASE

- |   |   |   |   |
|---|---|---|---|
| 1 | This information is released by the UK Government for Defence purposes only.  | 3 | This information may be disclosed only within the Defence Department of the recipient Government, except as otherwise authorized by Ministry of Defence (Army). |
| 2 | This information must be afforded the same degree of protection as that afforded to information of an equivalent security marking originated by the recipient Government or as required by the recipient Government's security regulations. | 4 | This information may be subject to privately owned rights.  |

THIS DOCUMENT IS THE PROPERTY OF HER BRITANNIC MAJESTY'S GOVERNMENT, and is issued for the information of such persons only as need to know its contents in the course of their official duties. Any person finding this document should hand it to a British forces unit or to a police station for its safe return to the MINISTRY OF DEFENCE (Dsy (Pol)), MAIN BUILDING, WHITEHALL, LONDON SW1A 2HB with particulars of how and where found. THE UNAUTHORIZED RETENTION OR DESTRUCTION OF THIS DOCUMENT MAY BE AN OFFENCE UNDER THE OFFICIAL SECRETS ACTS OF 1911-1989. (When released to persons outside Government service, this document is issued on a personal basis and the recipient to whom it may be entrusted in confidence, within the provision of the Official Secrets Acts 1911-1989, is personally responsible for its safe custody and for seeing that its contents are disclosed only to authorized persons).

**CARRIER, PERSONNEL, FULL TRACKED, FV 432 MK 2 AND 2/1**

**MODIFICATION INSTRUCTION NO. 1**

---

**SUBJECT: Flame switch control box**

**CANCELLATION**

**INTRODUCTION**

1 AESP 2350-T-251-811 Mod Instr No. 1, EMER E107/2 Mod Instr 82 is hereby cancelled. This modification is applicable to MK 1 vehicles only.

**ACTION**

- 2 Amend AESP 2350-T-251-811 Mod Instr 1, EMER E107/2 modification index accordingly.
- 3 File this Page 1/2 in place of Mod Instr No. 82 dated Oct 69, all pages of which are to be destroyed.

**CONDITIONS OF RELEASE**

- |   |   |   |   |
|---|---|---|---|
| 1 | This information is released by the UK Government for Defence purposes only.  | 3 | This information may be disclosed only within the Defence Department of the recipient Government, except as otherwise authorized by Ministry of Defence (Army). |
| 2 | This information must be afforded the same degree of protection as that afforded to information of an equivalent security marking originated by the recipient Government or as required by the recipient Government's security regulations. | 4 | This information may be subject to privately owned rights.  |

THIS DOCUMENT IS THE PROPERTY OF HER BRITANNIC MAJESTY'S GOVERNMENT, and is issued for the information of such persons only as need to know its contents in the course of their official duties. Any person finding this document should hand it to a British forces unit or to a police station for its safe return to the MINISTRY OF DEFENCE (Dsy (Pol)), MAIN BUILDING, WHITEHALL, LONDON SW1A 2HB with particulars of how and where found. THE UNAUTHORIZED RETENTION OR DESTRUCTION OF THIS DOCUMENT MAY BE AN OFFENCE UNDER THE OFFICIAL SECRETS ACTS OF 1911-1989. (When released to persons outside Government service, this document is issued on a personal basis and the recipient to whom it may be entrusted in confidence, within the provision of the Official Secrets Acts 1911-1989, is personally responsible for its safe custody and for seeing that its contents are disclosed only to authorized persons).

**CARRIER, PERSONNEL, FULL TRACKED, FV432 MK 2 AND 2/1  
MODIFICATION INSTRUCTION NO. 1 (EMER TV E107/2 Mod Instr No 83)**

**SUBJECT: Battery charge switch guard**

**CANCELLATION**

**INTRODUCTION**

- 1 AESP 2350-T-251-811 Mod Instr No. 1, EMER TV E107 Mod Instr No.83 dated Nov 69 is hereby cancelled. The details of this modification have been incorporated into the build standard.

**ACTION**

- 2 Amend AESP 2350-T-251-811 Mod Instr No.1, EMER TV E107/2 modification index accordingly
- 3 File this Page 1/2 in place of Mod Instr No. 83 dated Nov 69, all pages of which are to be destroyed.

**CONDITIONS OF RELEASE**

- |   |   |
|---|---|
| 1 This information is released by the UK Government for Defence purposes only.  | 3 This information may be disclosed only within the Defence Department of the recipient Government, except as otherwise authorized by Ministry of Defence (Army). |
| 2 This information must be afforded the same degree of protection as that afforded to information of an equivalent security marking originated by the recipient Government or as required by the recipient Government's security regulations. | 4 This information may be subject to privately owned rights.  |

THIS DOCUMENT IS THE PROPERTY OF HER BRITANNIC MAJESTY'S GOVERNMENT, and is issued for the information of such persons only as need to know its contents in the course of their official duties. Any person finding this document should hand it to a British forces unit or to a police station for its safe return to the MINISTRY OF DEFENCE (Dsy (Pol)), MAIN BUILDING, WHITEHALL, LONDON SW1A 2HB with particulars of how and where found. THE UNAUTHORIZED RETENTION OR DESTRUCTION OF THIS DOCUMENT MAY BE AN OFFENCE UNDER THE OFFICIAL SECRETS ACTS OF 1911-1989. (When released to persons outside Government service, this document is issued on a personal basis and the recipient to whom it may be entrusted in confidence, within the provision of the Official Secrets Acts 1911-1989, is personally responsible for its safe custody and for seeing that its contents are disclosed only to authorized persons).

**CARRIER, PERSONNEL, FULL TRACKED, FV432 MK 2 AND 2/1  
MODIFICATION INSTRUCTION NO. 1 (EMER TV E107/2 Mod Instr No 84)**

**SUBJECT: Prevention of damage to 5.1 in. fan motor relay**

**CANCELLATION**

**INTRODUCTION**

- 1 AESP 2350-T-251-811 Mod Instr No. 1, EMER TV E107 Mod Instr No.84 dated Jun 70 is hereby cancelled. The details of this modification have been incorporated into the build standard.

**ACTION**

- 2 Amend AESP 2350-T-251-811 Mod Instr No.1, EMER TV E107/2 modification index accordingly
- 3 File this Page 1/2 in place of Mod Instr No. 84 dated Jun 70, all pages of which are to be destroyed.



CONDITIONS OF RELEASE

- |   |   |   |   |
|---|---|---|---|
| 1 | This information is released by the UK Government for Defence purposes only.  | 3 | This information may be disclosed only within the Defence Department of the recipient Government, except as otherwise authorized by Ministry of Defence (Army). |
| 2 | This information must be afforded the same degree of protection as that afforded to information of an equivalent security marking originated by the recipient Government or as required by the recipient Government's security regulations. | 4 | This information may be subject to privately owned rights.  |

THIS DOCUMENT IS THE PROPERTY OF HER BRITANNIC MAJESTY'S GOVERNMENT, and is issued for the information of such persons only as need to know its contents in the course of their official duties. Any person finding this document should hand it to a British forces unit or to a police station for its safe return to the MINISTRY OF DEFENCE (Dsy (Pol)), MAIN BUILDING, WHITEHALL, LONDON SW1A 2HB with particulars of how and where found. THE UNAUTHORIZED RETENTION OR DESTRUCTION OF THIS DOCUMENT MAY BE AN OFFENCE UNDER THE OFFICIAL SECRETS ACTS OF 1911-1989. (When released to persons outside Government service, this document is issued on a personal basis and the recipient to whom it may be entrusted in confidence, within the provision of the Official Secrets Acts 1911-1989, is personally responsible for its safe custody and for seeing that its contents are disclosed only to authorized persons).

**CARRIER, PERSONNEL, FULL TRACKED, FV 432 MK 2 AND 2/1**

**MODIFICATION INSTRUCTION NO. 1**

---

**SUBJECT: Carriage, Miser mount**

**CANCELLATION**

**INTRODUCTION**

1 AESP 2350-T-251-811 Mod Instr No. 1, EMER E107/2 Mod Instr 85 is hereby cancelled. This modification was applicable to equipment that has been declared obsolete, and is therefore no longer required.

**ACTION**

- 2 Amend AESP 2350-T-251-811 Mod Instr 1, EMER E107/2 modification index accordingly.
- 3 File this Page 1/2 in place of Mod Instr No. 85 dated Jun 70, all pages of which are to be destroyed.

**CONDITIONS OF RELEASE**

- |   |   |
|---|---|
| 1     This information is released by the UK Government for Defence purposes only.  | 3     This information may be disclosed only within the Defence Department of the recipient Government, except as otherwise authorized by Ministry of Defence (Army). |
| 2     This information must be afforded the same degree of protection as that afforded to information of an equivalent security marking originated by the recipient Government or as required by the recipient Government's security regulations. | 4     This information may be subject to privately owned rights.  |

THIS DOCUMENT IS THE PROPERTY OF HER BRITANNIC MAJESTY'S GOVERNMENT, and is issued for the information of such persons only as need to know its contents in the course of their official duties. Any person finding this document should hand it to a British forces unit or to a police station for its safe return to the MINISTRY OF DEFENCE (Dsy (Pol)), MAIN BUILDING, WHITEHALL, LONDON SW1A 2HB with particulars of how and where found. THE UNAUTHORIZED RETENTION OR DESTRUCTION OF THIS DOCUMENT MAY BE AN OFFENCE UNDER THE OFFICIAL SECRETS ACTS OF 1911-1989. (When released to persons outside Government service, this document is issued on a personal basis and the recipient to whom it may be entrusted in confidence, within the provision of the Official Secrets Acts 1911-1989, is personally responsible for its safe custody and for seeing that its contents are disclosed only to authorized persons).

**CARRIER, PERSONNEL, FULL TRACKED, FV432 MK 2 AND 2/1  
MODIFICATION INSTRUCTION NO. 1 (EMER TV E107/2 Mod Instr No 86)**

**SUBJECT: Air conditioning equipment**

**CANCELLATION**

**INTRODUCTION**

- 1     AESP 2350-T-251-811 Mod Instr No. 1, EMER TV E107 Mod Instr No.86 dated Jun 71 is hereby cancelled. This modification was suspended in Jul 73, pending a new scheme being investigated. A new scheme was never devised, hence the modification is now cancelled in it's entirety.

**ACTION**

- 2     Amend AESP 2350-T-251-811 Mod Instr No.1, EMER TV E107/2 modification index accordingly
- 3     File this Page 1/2 in place of Mod Instr No. 86 dated Jun 71, all pages of which are to be destroyed.

**CONDITIONS OF RELEASE**

- |   |   |   |   |
|---|---|---|---|
| 1 | This information is released by the UK Government for Defence purposes only.  | 3 | This information may be disclosed only within the Defence Department of the recipient Government, except as otherwise authorized by Ministry of Defence (Army). |
| 2 | This information must be afforded the same degree of protection as that afforded to information of an equivalent security marking originated by the recipient Government or as required by the recipient Government's security regulations. | 4 | This information may be subject to privately owned rights.  |

THIS DOCUMENT IS THE PROPERTY OF HER BRITANNIC MAJESTY'S GOVERNMENT, and is issued for the information of such persons only as need to know its contents in the course of their official duties. Any person finding this document should hand it to a British forces unit or to a police station for its safe return to the MINISTRY OF DEFENCE (Dsy (Pol)), MAIN BUILDING, WHITEHALL, LONDON SW1A 2HB with particulars of how and where found. THE UNAUTHORIZED RETENTION OR DESTRUCTION OF THIS DOCUMENT MAY BE AN OFFENCE UNDER THE OFFICIAL SECRETS ACTS OF 1911-1989. (When released to persons outside Government service, this document is issued on a personal basis and the recipient to whom it may be entrusted in confidence, within the provision of the Official Secrets Acts 1911-1989, is personally responsible for its safe custody and for seeing that its contents are disclosed only to authorized persons).

**CARRIER, PERSONNEL, FULL TRACKED, FV432 MK 2 AND 2/1  
MODIFICATION INSTRUCTION NO. 1 (EMER TV E107/2 Mod Instr No 87)**

**SUBJECT: Locking of commanders hatch**

**CANCELLATION**

**INTRODUCTION**

- 1 AESP 2350-T-251-811 Mod Instr No. 1, EMER TV E107 Mod Instr No.87 dated Nov 70 is hereby cancelled. The details of this modification have been incorporated into the build standard.

**ACTION**

- 2 Amend AESP 2350-T-251-811 Mod Instr No.1, EMER TV E107/2 modification index accordingly
- 3 File this Page 1/2 in place of Mod Instr No. 87 dated Nov 70, all pages of which are to be destroyed.

**CONDITIONS OF RELEASE**

- |   |   |   |   |
|---|---|---|---|
| 1 | This information is released by the UK Government for Defence purposes only.  | 3 | This information may be disclosed only within the Defence Department of the recipient Government, except as otherwise authorized by Ministry of Defence (Army). |
| 2 | This information must be afforded the same degree of protection as that afforded to information of an equivalent security marking originated by the recipient Government or as required by the recipient Government's security regulations. | 4 | This information may be subject to privately owned rights.  |

THIS DOCUMENT IS THE PROPERTY OF HER BRITANNIC MAJESTY'S GOVERNMENT, and is issued for the information of such persons only as need to know its contents in the course of their official duties. Any person finding this document should hand it to a British forces unit or to a police station for its safe return to the MINISTRY OF DEFENCE (Dsy (Pol)), MAIN BUILDING, WHITEHALL, LONDON SW1A 2HB with particulars of how and where found. THE UNAUTHORIZED RETENTION OR DESTRUCTION OF THIS DOCUMENT MAY BE AN OFFENCE UNDER THE OFFICIAL SECRETS ACTS OF 1911-1989. (When released to persons outside Government service, this document is issued on a personal basis and the recipient to whom it may be entrusted in confidence, within the provision of the Official Secrets Acts 1911-1989, is personally responsible for its safe custody and for seeing that its contents are disclosed only to authorized persons).

**CARRIER, PERSONNEL, FULL TRACKED, FV432 MK 2 AND 2/1  
MODIFICATION INSTRUCTION NO. 1 (EMER TV E107/2 Mod Instr No 88)**

**SUBJECT: Locking of commanders hatch**

**CANCELLATION**

**INTRODUCTION**

- 1 AESP 2350-T-251-811 Mod Instr No. 1, EMER TV E107 Mod Instr No.88 dated Dec 70 is hereby cancelled. The details of this modification have been incorporated into CES No. AC 34926.

**ACTION**

- 2 Amend AESP 2350-T-251-811 Mod Instr No.1, EMER TV E107/2 modification index accordingly
- 3 File this Page 1/2 in place of Mod Instr No. 88 dated Dec 70, all pages of which are to be destroyed.

**CONDITIONS OF RELEASE**

- |   |   |   |   |
|---|---|---|---|
| 1 | This information is released by the UK Government for Defence purposes only.  | 3 | This information may be disclosed only within the Defence Department of the recipient Government, except as otherwise authorized by Ministry of Defence (Army). |
| 2 | This information must be afforded the same degree of protection as that afforded to information of an equivalent security marking originated by the recipient Government or as required by the recipient Government's security regulations. | 4 | This information may be subject to privately owned rights.  |

THIS DOCUMENT IS THE PROPERTY OF HER BRITANNIC MAJESTY'S GOVERNMENT, and is issued for the information of such persons only as need to know its contents in the course of their official duties. Any person finding this document should hand it to a British forces unit or to a police station for its safe return to the MINISTRY OF DEFENCE (Dsy (Pol)), MAIN BUILDING, WHITEHALL, LONDON SW1A 2HB with particulars of how and where found. THE UNAUTHORIZED RETENTION OR DESTRUCTION OF THIS DOCUMENT MAY BE AN OFFENCE UNDER THE OFFICIAL SECRETS ACTS OF 1911-1989. (When released to persons outside Government service, this document is issued on a personal basis and the recipient to whom it may be entrusted in confidence, within the provision of the Official Secrets Acts 1911-1989, is personally responsible for its safe custody and for seeing that its contents are disclosed only to authorized persons).

**CARRIER, PERSONNEL, FULL TRACKED, FV432 MK 2 AND 2/1  
MODIFICATION INSTRUCTION NO. 1 (EMER TV E107/2 Mod Instr No 89)**

**SUBJECT: Fitting of improved type of engine cover sealing strips**

**CANCELLATION**

**INTRODUCTION**

- 1 AESP 2350-T-251-811 Mod Instr No. 1, EMER TV E107 Mod Instr No.89 dated Apr 80 is hereby cancelled. The details of this modification have been incorporated into the build standard.

**ACTION**

- 2 Amend AESP 2350-T-251-811 Mod Instr No.1, EMER TV E107/2 modification index accordingly
- 3 File this Page 1/2 in place of Mod Instr No. 89 dated Apr 80, all pages of which are to be destroyed.

CONDITIONS OF RELEASE  
(Applicable to copies supplied with Ministry of Defence  
approval to Commonwealth and Foreign Governments)

1. This information is released by the United Kingdom Government to the recipient Government for Defence purposes only.
2. This information must be accorded the same degree of security protection as that accorded thereto by the United Kingdom Government.
3. This information may be disclosed only within the Defence Department of the recipient Government, except as otherwise authorized by the Ministry of Defence.
4. This information may be subject to privately owned rights.

CARRIER, PERSONNEL, FULL TRACKED, FV 432, MK 1, 2 AND 2/1  
(MORTAR ROLE ONLY)

TECHNICAL HANDBOOK - MODIFICATION INSTRUCTION

SUB-TITLE: Commander's hatch, external locking device

1. Introduction

In the mortar role the FV 432 rear door cannot be used for entry/exit due to the installation of ammunition racking. Entry/exit is therefore made through the Commander's hatch. To ensure security of the vehicle when unattended an external locking device is fitted to the hatch door.

2. Priority: Group 'B' (Mgmt N 097 refers).

3. Estimated time required:-

Stripping and assembling: 1/2 man-hour  
Embodiment: 3 man-hours

4. Items affected: Commander's hatch and periscope guard on all FV 432 vehicles used in the mortar role.

5. Action required by:-

a. Units and establishments holding equipment

- (1) Enter EMER No, sub title and Army Modification Code in equipment log book.
- (2) Request REME to modify equipment.

b. Units authorized to carry out unit, field or base repairs

- (1) When requested by units or during overhaul carry out this modification.
- (2) Record completion of modification in equipment log book against appropriate entry.

c. All recipients of this EMER

Add particulars to Tkd Veh E 107/2 Mod Instr Index.

6. Stores, tools and equipment:-

a. Stores to be obtained locally

<u>VAOS</u> <u>Section</u>	<u>Part No</u>	<u>Designation</u>	<u>Qty</u> <u>per eqpt</u>
G1	5306-99-941-1601	Bolt, 'S' steel, hex hd, zc pltd, 5/8 in. UNC x 3 in. lg. (thread to be extended as necessary)	1
G1	5310-99-941-8639	Washer, flat, steel, zc pltd. 0.625 in. i.d. x 1.25 in. o.d. x 0.116 in. thick	2
G2	9510-99-960-5768	Steel bar, flat, 7/8 in. x 1/4 in.	1 lb
G2	9510-99-960-5773	Steel bar, flat, 1 in. x 5/16 in.	2 lb

b. Stores to be modified

LV9ACR	2510-99-865-6502 (FV 413797)	Housing, periscope, Commander's cupola.	1
LV9ACR	5306-99-865-6554 (FV 524664)	Bolt, internally relieved body, brass, r.h. handle.	1

7. Sequence of operations:-

a. Refer to ISPL Army Code No. 14660 Page H2.

Remove r.h. locking handle assy from Commander's hatch by loosening off the 7/8 in. lock nut (item 46) and unscrewing the brass bolt (item 43-FV 524664) from outside of hatch. Check spring, helical torsion (item 44) for serviceability. Renew if necessary.

b. See Fig 1. Manufacture two padlock lugs and a swing bar to details shown from the material listed at para 6.a.

c. See Fig 2. Drill a 5/8 in. dia clearance hole through head of brass bolt (FV 524664) to the start of the internal thread. Check that the 5/8 in. UNC x 3 in. long bolt listed at para 6.a can be screwed right through the centre of the brass bolt (FV 524664) to within approx 1/2 in. of 5/8 in. UNC bolt head. It may be necessary to extend the thread on the bolt shank.

d. Remove the 5/8 in. UNC x 1.1/2 in. long bolt tack welded to locking handle and replace bolt removed with 5/8 in. UNC x 3 in. long bolt. Tack weld head of bolt to locking handle.

e. See Fig 3.a. Re-assemble locking handle assy to Commander's hatch with the longer 5/8 in. UNC bolt protruding through outside of hatch. Check that the locking handle functions correctly with hatch in closed position. Adjust if necessary.

f. See Fig 3.b.

(1) With Commander's hatch in the closed position (both handles fully locked) assemble the 5/8 washer/s and manufactured swing bar to the protruding 5/8 in. UNC bolt.

(2) Locate and mark off the relative positions of both padlock lugs on periscope guard and swing bar with 1/2 in. dia hole of each padlock lug in line. Weld both padlock lugs in position as previously marked off.

Note: The distance between centres of the 5/8 in. UNC bolt and 1/2 in. dia hole in padlock lug on swing bar should be approx 6.3/8 in.

(3) Using the rear door padlock, lock both padlock lugs together and then weld the other end of swing bar to the protruding end of 5/8 in. UNC bolt.

g. Check operation of swing bar in conjunction with the locking handle to ensure they 'lock' and 'unlock' simultaneously.

h. Paint bare metal surfaces.

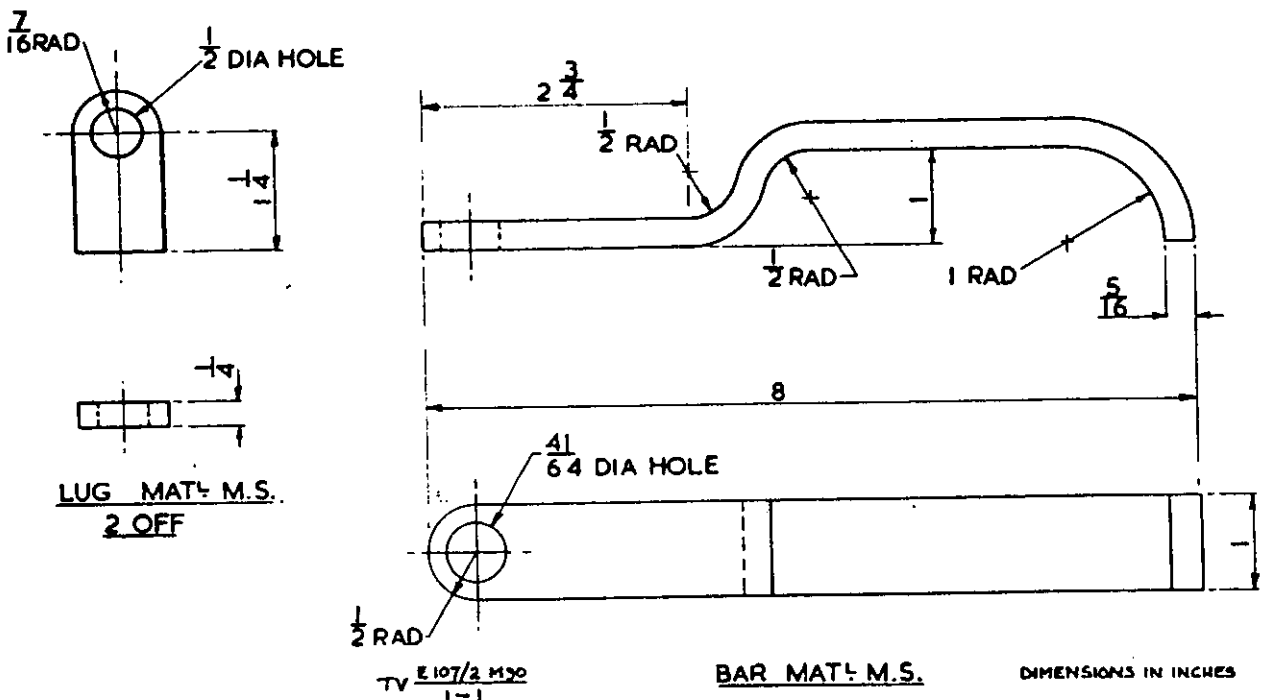

Fig 1. Manufacturing details for padlock lugs and swing bar



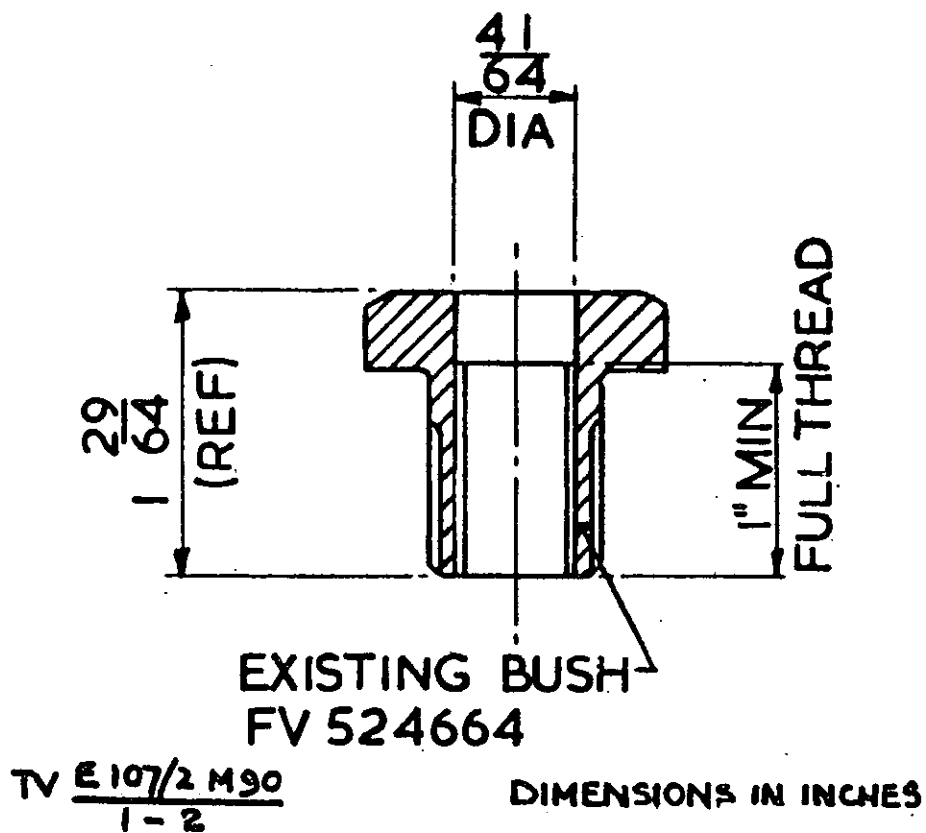
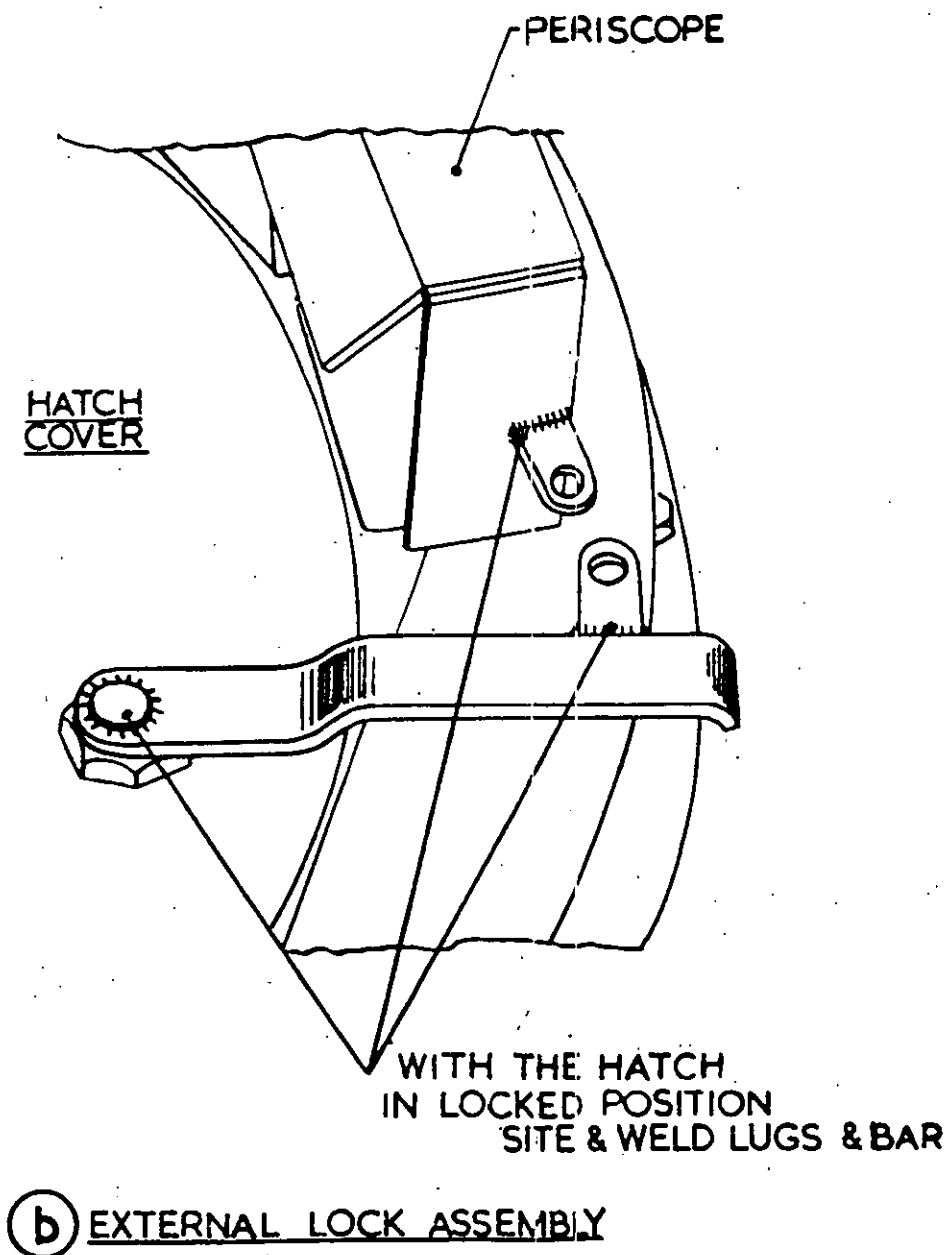
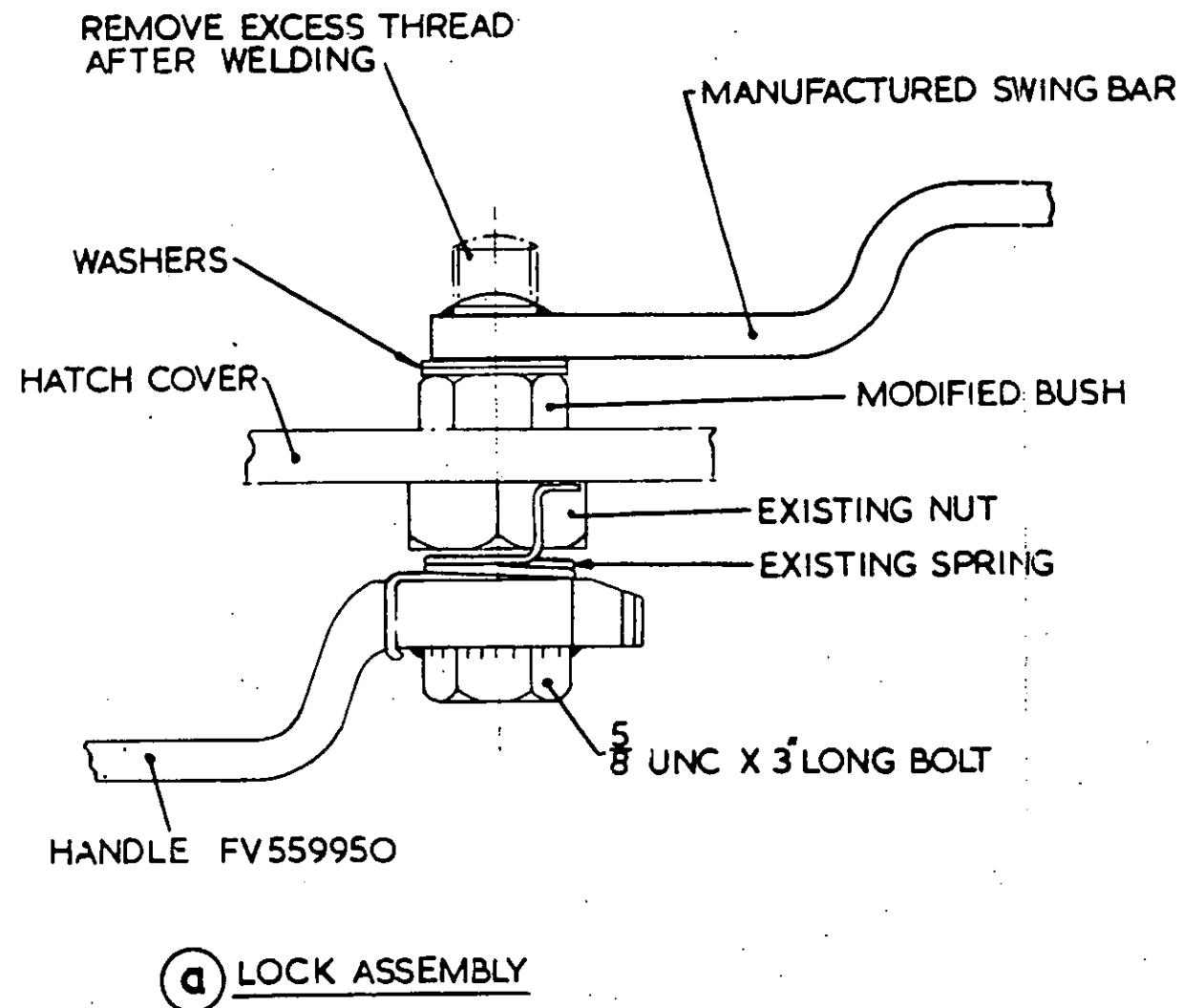

Fig 2. Details of modified bolt brass (FV 524664)



TV E 107/2 M90  
1-3

DIMENSIONS IN INCHES

Fig 3. Assembly detail

Authority GS(OR)17.A/58/MODS/1432 dtd.30 Dec.70  
Veh Investigation Br 725/07

**CONDITIONS OF RELEASE**

- |   |   |
|---|---|
| 1 This information is released by the UK Government for Defence purposes only.  | 3 This information may be disclosed only within the Defence Department of the recipient Government, except as otherwise authorized by Ministry of Defence (Army). |
| 2 This information must be afforded the same degree of protection as that afforded to information of an equivalent security marking originated by the recipient Government or as required by the recipient Government's security regulations. | 4 This information may be subject to privately owned rights.  |

THIS DOCUMENT IS THE PROPERTY OF HER BRITANNIC MAJESTY'S GOVERNMENT, and is issued for the information of such persons only as need to know its contents in the course of their official duties. Any person finding this document should hand it to a British forces unit or to a police station for its safe return to the MINISTRY OF DEFENCE (Dsy (Pol)), MAIN BUILDING, WHITEHALL, LONDON SW1A 2HB with particulars of how and where found. THE UNAUTHORIZED RETENTION OR DESTRUCTION OF THIS DOCUMENT MAY BE AN OFFENCE UNDER THE OFFICIAL SECRETS ACTS OF 1911-1989. (When released to persons outside Government service, this document is issued on a personal basis and the recipient to whom it may be entrusted in confidence, within the provision of the Official Secrets Acts 1911-1989, is personally responsible for its safe custody and for seeing that its contents are disclosed only to authorized persons).

**CARRIER, PERSONNEL, FULL TRACKED, FV 432 MK 2 AND 2/1**

**MODIFICATION INSTRUCTION NO. 1**

**SUBJECT: Map tables**

**CANCELLATION**

**INTRODUCTION**

1 AESP 2350-T-251-811 Mod Instr No. 1, EMER E107/2 Mod Instr 91 is hereby cancelled. This modification was applicable to equipment that has been declared obsolete, and is therefore no longer required.

**ACTION**

- 2 Amend AESP 2350-T-251-811 Mod Instr 1, EMER E107/2 modification index accordingly.
- 3 File this Page 1/2 in place of Mod Instr No. 91 dated Oct 71, all pages of which are to be destroyed.

**CONDITIONS OF RELEASE**

- |   |   |
|---|---|
| 1     This information is released by the UK Government for Defence purposes only.  | 3     This information may be disclosed only within the Defence Department of the recipient Government, except as otherwise authorized by Ministry of Defence (Army). |
| 2     This information must be afforded the same degree of protection as that afforded to information of an equivalent security marking originated by the recipient Government or as required by the recipient Government's security regulations. | 4     This information may be subject to privately owned rights.  |

THIS DOCUMENT IS THE PROPERTY OF HER BRITANNIC MAJESTY'S GOVERNMENT, and is issued for the information of such persons only as need to know its contents in the course of their official duties. Any person finding this document should hand it to a British forces unit or to a police station for its safe return to the MINISTRY OF DEFENCE (Dsy (Pol)), MAIN BUILDING, WHITEHALL, LONDON SW1A 2HB with particulars of how and where found. THE UNAUTHORIZED RETENTION OR DESTRUCTION OF THIS DOCUMENT MAY BE AN OFFENCE UNDER THE OFFICIAL SECRETS ACTS OF 1911-1989. (When released to persons outside Government service, this document is issued on a personal basis and the recipient to whom it may be entrusted in confidence, within the provision of the Official Secrets Acts 1911-1989, is personally responsible for its safe custody and for seeing that its contents are disclosed only to authorized persons).

**CARRIER, PERSONNEL, FULL TRACKED, FV 432 MK 2 AND 2/1**

**MODIFICATION INSTRUCTION NO. 1**

---

**SUBJECT: Rarden turret**

**CANCELLATION**

**INTRODUCTION**

1     AESP 2350-T-251-811 Mod Instr No. 1, EMER E107/2 Mod Instr 92 is hereby cancelled. This modification was applicable to equipment that has been declared obsolete, and is therefore no longer required.

**ACTION**

- 2     Amend AESP 2350-T-251-811 Mod Instr 1, EMER E107/2 modification index accordingly.
- 3     File this Page 1/2 in place of Mod Instr No. 92 dated Mar 74, all pages of which are to be destroyed.

**CONDITIONS OF RELEASE**

- |   |   |
|---|---|
| 1 This information is released by the UK Government for Defence purposes only.  | 3 This information may be disclosed only within the Defence Department of the recipient Government, except as otherwise authorized by Ministry of Defence (Army). |
| 2 This information must be afforded the same degree of protection as that afforded to information of an equivalent security marking originated by the recipient Government or as required by the recipient Government's security regulations. | 4 This information may be subject to privately owned rights.  |

THIS DOCUMENT IS THE PROPERTY OF HER BRITANNIC MAJESTY'S GOVERNMENT, and is issued for the information of such persons only as need to know its contents in the course of their official duties. Any person finding this document should hand it to a British forces unit or to a police station for its safe return to the MINISTRY OF DEFENCE (Dsy (Pol)), MAIN BUILDING, WHITEHALL, LONDON SW1A 2HB with particulars of how and where found. THE UNAUTHORIZED RETENTION OR DESTRUCTION OF THIS DOCUMENT MAY BE AN OFFENCE UNDER THE OFFICIAL SECRETS ACTS OF 1911-1989. (When released to persons outside Government service, this document is issued on a personal basis and the recipient to whom it may be entrusted in confidence, within the provision of the Official Secrets Acts 1911-1989, is personally responsible for its safe custody and for seeing that its contents are disclosed only to authorized persons).

**CARRIER, PERSONNEL, FULL TRACKED, FV 432 MK 2 AND 2/1**

**MODIFICATION INSTRUCTION NO. 1**

---

**SUBJECT: Miser mount**

**CANCELLATION**

**INTRODUCTION**

1 AESP 2350-T-251-811 Mod Instr No. 1, EMER E107/2 Mod Instr 93 is hereby cancelled. This modification was applicable to equipment that has been declared obsolete, and is therefore no longer required.

**ACTION**

- 2 Amend AESP 2350-T-251-811 Mod Instr 1, EMER E107/2 modification index accordingly.
- 3 File this Page 1/2 in place of Mod Instr No. 93 dated Jan 74, all pages of which are to be destroyed.

**CONDITIONS OF RELEASE**

- |   |   |
|---|---|
| 1     This information is released by the UK Government for Defence purposes only.  | 3     This information may be disclosed only within the Defence Department of the recipient Government, except as otherwise authorized by Ministry of Defence (Army). |
| 2     This information must be afforded the same degree of protection as that afforded to information of an equivalent security marking originated by the recipient Government or as required by the recipient Government's security regulations. | 4     This information may be subject to privately owned rights.  |

THIS DOCUMENT IS THE PROPERTY OF HER BRITANNIC MAJESTY'S GOVERNMENT, and is issued for the information of such persons only as need to know its contents in the course of their official duties. Any person finding this document should hand it to a British forces unit or to a police station for its safe return to the MINISTRY OF DEFENCE (Dsy (Pol)), MAIN BUILDING, WHITEHALL, LONDON SW1A 2HB with particulars of how and where found. THE UNAUTHORIZED RETENTION OR DESTRUCTION OF THIS DOCUMENT MAY BE AN OFFENCE UNDER THE OFFICIAL SECRETS ACTS OF 1911-1989. (When released to persons outside Government service, this document is issued on a personal basis and the recipient to whom it may be entrusted in confidence, within the provision of the Official Secrets Acts 1911-1989, is personally responsible for its safe custody and for seeing that its contents are disclosed only to authorized persons).

**CARRIER, PERSONNEL, FULL TRACKED, FV 432 MK 2 AND 2/1**

**MODIFICATION INSTRUCTION NO. 1**

---

**SUBJECT: Tachometer cable guard**

**CANCELLATION**

**INTRODUCTION**

- 1     AESP 2350-T-251-811 Mod Instr No. 1, EMER E107/2 Mod Instr 94 is hereby cancelled. This modification is applicable to Mk 1 vehicles only.

**ACTION**

- 2     Amend AESP 2350-T-251-811 Mod Instr 1, EMER E107/2 modification index accordingly.
- 3     File this Page 1/2 in place of Mod Instr No. 94 dated Jun 76, all pages of which are to be destroyed.

**CONDITIONS OF RELEASE**

- |   |   |
|---|---|
| 1     This information is released by the UK Government for Defence purposes only.  | 3     This information may be disclosed only within the Defence Department of the recipient Government, except as otherwise authorized by Ministry of Defence (Army). |
| 2     This information must be afforded the same degree of protection as that afforded to information of an equivalent security marking originated by the recipient Government or as required by the recipient Government's security regulations. | 4     This information may be subject to privately owned rights.  |

THIS DOCUMENT IS THE PROPERTY OF HER BRITANNIC MAJESTY'S GOVERNMENT, and is issued for the information of such persons only as need to know its contents in the course of their official duties. Any person finding this document should hand it to a British forces unit or to a police station for its safe return to the MINISTRY OF DEFENCE (Dsy (Pol)), MAIN BUILDING, WHITEHALL, LONDON SW1A 2HB with particulars of how and where found. THE UNAUTHORIZED RETENTION OR DESTRUCTION OF THIS DOCUMENT MAY BE AN OFFENCE UNDER THE OFFICIAL SECRETS ACTS OF 1911-1989. (When released to persons outside Government service, this document is issued on a personal basis and the recipient to whom it may be entrusted in confidence, within the provision of the Official Secrets Acts 1911-1989, is personally responsible for its safe custody and for seeing that its contents are disclosed only to authorized persons).

**CARRIER, PERSONNEL, FULL TRACKED, FV432 MK 2 AND 2/1  
MODIFICATION INSTRUCTION NO. 1 (EMER TV E107/2 Mod Instr No 95)**

**SUBJECT: Stowage facilities**

**CANCELLATION**

**INTRODUCTION**

- 1     AESP 2350-T-251-811 Mod Instr No. 1, EMER TV E107 Mod Instr No.95 dated Dec 74 is hereby cancelled. The details of this modification have been incorporated into the build standard.

**ACTION**

- 2     Amend AESP 2350-T-251-811 Mod Instr No.1, EMER TV E107/2 modification index accordingly
- 3     File this Page 1/2 in place of Mod Instr No. 95 dated Dec 74, all pages of which are to be destroyed.

**CONDITIONS OF RELEASE**

- |   |   |
|---|---|
| 1     This information is released by the UK Government for Defence purposes only.  | 3     This information may be disclosed only within the Defence Department of the recipient Government, except as otherwise authorized by Ministry of Defence (Army). |
| 2     This information must be afforded the same degree of protection as that afforded to information of an equivalent security marking originated by the recipient Government or as required by the recipient Government's security regulations. | 4     This information may be subject to privately owned rights.  |

THIS DOCUMENT IS THE PROPERTY OF HER BRITANNIC MAJESTY'S GOVERNMENT, and is issued for the information of such persons only as need to know its contents in the course of their official duties. Any person finding this document should hand it to a British forces unit or to a police station for its safe return to the MINISTRY OF DEFENCE (Dsy (Pol)), MAIN BUILDING, WHITEHALL, LONDON SW1A 2HB with particulars of how and where found. THE UNAUTHORIZED RETENTION OR DESTRUCTION OF THIS DOCUMENT MAY BE AN OFFENCE UNDER THE OFFICIAL SECRETS ACTS OF 1911-1989. (When released to persons outside Government service, this document is issued on a personal basis and the recipient to whom it may be entrusted in confidence, within the provision of the Official Secrets Acts 1911-1989, is personally responsible for its safe custody and for seeing that its contents are disclosed only to authorized persons).

**CARRIER, PERSONNEL, FULL TRACKED, FV 432 MK 2 AND 2/1**

**MODIFICATION INSTRUCTION NO. 1**

---

**SUBJECT: Rarden turret, rotary base junction**

**CANCELLATION**

**INTRODUCTION**

1     AESP 2350-T-251-811 Mod Instr No. 1, EMER E107/2 Mod Instr 96 is hereby cancelled. This modification was applicable to equipment that has been declared obsolete, and is therefore no longer required.

**ACTION**

- 2     Amend AESP 2350-T-251-811 Mod Instr 1, EMER E107/2 modification index accordingly.
- 3     File this Page 1/2 in place of Mod Instr No. 96 dated Jan 76, all pages of which are to be destroyed.



**CONDITIONS OF RELEASE**

- |   |   |   |   |
|---|---|---|---|
| 1 | This information is released by the UK Government for Defence purposes only.  | 3 | This information may be disclosed only within the Defence Department of the recipient Government, except as otherwise authorized by Ministry of Defence (Army). |
| 2 | This information must be afforded the same degree of protection as that afforded to information of an equivalent security marking originated by the recipient Government or as required by the recipient Government's security regulations. | 4 | This information may be subject to privately owned rights.  |

THIS DOCUMENT IS THE PROPERTY OF HER BRITANNIC MAJESTY'S GOVERNMENT, and is issued for the information of such persons only as need to know its contents in the course of their official duties. Any person finding this document should hand it to a British forces unit or to a police station for its safe return to the MINISTRY OF DEFENCE (Dsy (Pol)), MAIN BUILDING, WHITEHALL, LONDON SW1A 2HB with particulars of how and where found. THE UNAUTHORIZED RETENTION OR DESTRUCTION OF THIS DOCUMENT MAY BE AN OFFENCE UNDER THE OFFICIAL SECRETS ACTS OF 1911-1989. (When released to persons outside Government service, this document is issued on a personal basis and the recipient to whom it may be entrusted in confidence, within the provision of the Official Secrets Acts 1911-1989, is personally responsible for its safe custody and for seeing that its contents are disclosed only to authorized persons).

**CARRIER, PERSONNEL, FULL TRACKED, FV 432 MK 2 AND 2/1**

**MODIFICATION INSTRUCTION NO. 1**

---

**SUBJECT: Rarden turret, smoke discharger**

**CANCELLATION**

**INTRODUCTION**

1 AESP 2350-T-251-811 Mod Instr No. 1, EMER E107/2 Mod Instr 97 is hereby cancelled. This modification was applicable to equipment that has been declared obsolete, and is therefore no longer required.

**ACTION**

- 2 Amend AESP 2350-T-251-811 Mod Instr 1, EMER E107/2 modification index accordingly.
- 3 File this Page 1/2 in place of Mod Instr No. 97 dated Sep 75, all pages of which are to be destroyed.

**CONDITIONS OF RELEASE**

- |   |   |
|---|---|
| 1     This information is released by the UK Government for Defence purposes only.  | 3     This information may be disclosed only within the Defence Department of the recipient Government, except as otherwise authorized by Ministry of Defence (Army). |
| 2     This information must be afforded the same degree of protection as that afforded to information of an equivalent security marking originated by the recipient Government or as required by the recipient Government's security regulations. | 4     This information may be subject to privately owned rights.  |

THIS DOCUMENT IS THE PROPERTY OF HER BRITANNIC MAJESTY'S GOVERNMENT, and is issued for the information of such persons only as need to know its contents in the course of their official duties. Any person finding this document should hand it to a British forces unit or to a police station for its safe return to the MINISTRY OF DEFENCE (Dsy (Pol)), MAIN BUILDING, WHITEHALL, LONDON SW1A 2HB with particulars of how and where found. THE UNAUTHORIZED RETENTION OR DESTRUCTION OF THIS DOCUMENT MAY BE AN OFFENCE UNDER THE OFFICIAL SECRETS ACTS OF 1911-1989. (When released to persons outside Government service, this document is issued on a personal basis and the recipient to whom it may be entrusted in confidence, within the provision of the Official Secrets Acts 1911-1989, is personally responsible for its safe custody and for seeing that its contents are disclosed only to authorized persons).

**CARRIER, PERSONNEL, FULL TRACKED, FV432 MK 2 AND 2/1  
MODIFICATION INSTRUCTION NO. 1 (EMER TV E107/2 Mod Instr No 98)**

**SUBJECT: Installation kit 81mm mortar – Traverse gearbox**

**CANCELLATION**

**INTRODUCTION**

- 1     AESP 2350-T-251-811 Mod Instr No. 1, EMER TV E107 Mod Instr No.98 dated Dec 75 is hereby cancelled. The details of this modification have been incorporated into the build standard.

**ACTION**

- 2     Amend AESP 2350-T-251-811 Mod Instr No.1, EMER TV E107/2 modification index accordingly
- 3     File this Page 1/2 in place of Mod Instr No. 98 dated Dec 75, all pages of which are to be destroyed.

**CONDITIONS OF RELEASE**

- |   |   |
|---|---|
| 1     This information is released by the UK Government for Defence purposes only.  | 3     This information may be disclosed only within the Defence Department of the recipient Government, except as otherwise authorized by Ministry of Defence (Army). |
| 2     This information must be afforded the same degree of protection as that afforded to information of an equivalent security marking originated by the recipient Government or as required by the recipient Government's security regulations. | 4     This information may be subject to privately owned rights.  |

THIS DOCUMENT IS THE PROPERTY OF HER BRITANNIC MAJESTY'S GOVERNMENT, and is issued for the information of such persons only as need to know its contents in the course of their official duties. Any person finding this document should hand it to a British forces unit or to a police station for its safe return to the MINISTRY OF DEFENCE (Dsy (Pol)), MAIN BUILDING, WHITEHALL, LONDON SW1A 2HB with particulars of how and where found. THE UNAUTHORIZED RETENTION OR DESTRUCTION OF THIS DOCUMENT MAY BE AN OFFENCE UNDER THE OFFICIAL SECRETS ACTS OF 1911-1989. (When released to persons outside Government service, this document is issued on a personal basis and the recipient to whom it may be entrusted in confidence, within the provision of the Official Secrets Acts 1911-1989, is personally responsible for its safe custody and for seeing that its contents are disclosed only to authorized persons).

**CARRIER, PERSONNEL, FULL TRACKED, FV432 MK 2 AND 2/1  
MODIFICATION INSTRUCTION NO. 1 (EMER TV E107/2 Mod Instr No 99)**

**SUBJECT: Collapsible fuel funnel – Outlet pipe coupling**

**CANCELLATION**

**INTRODUCTION**

- 1     AESP 2350-T-251-811 Mod Instr No. 1, EMER TV E107 Mod Instr No.99 dated Sep 76 is hereby cancelled. The details of this modification have been incorporated into the build standard.

**ACTION**

- 2     Amend AESP 2350-T-251-811 Mod Instr No.1, EMER TV E107/2 modification index accordingly
- 3     File this Page 1/2 in place of Mod Instr No. 99 dated Sep 76, all pages of which are to be destroyed.

**CONDITIONS OF RELEASE**

- |   |   |
|---|---|
| 1     This information is released by the UK Government for Defence purposes only.  | 3     This information may be disclosed only within the Defence Department of the recipient Government, except as otherwise authorized by Ministry of Defence (Army). |
| 2     This information must be afforded the same degree of protection as that afforded to information of an equivalent security marking originated by the recipient Government or as required by the recipient Government's security regulations. | 4     This information may be subject to privately owned rights.  |

THIS DOCUMENT IS THE PROPERTY OF HER BRITANNIC MAJESTY'S GOVERNMENT, and is issued for the information of such persons only as need to know its contents in the course of their official duties. Any person finding this document should hand it to a British forces unit or to a police station for its safe return to the MINISTRY OF DEFENCE (Dsy (Pol)), MAIN BUILDING, WHITEHALL, LONDON SW1A 2HB with particulars of how and where found. THE UNAUTHORIZED RETENTION OR DESTRUCTION OF THIS DOCUMENT MAY BE AN OFFENCE UNDER THE OFFICIAL SECRETS ACTS OF 1911-1989. (When released to persons outside Government service, this document is issued on a personal basis and the recipient to whom it may be entrusted in confidence, within the provision of the Official Secrets Acts 1911-1989, is personally responsible for its safe custody and for seeing that its contents are disclosed only to authorized persons).

**CARRIER, PERSONNEL, FULL TRACKED, FV 432 MK 2 AND 2/1**

**MODIFICATION INSTRUCTION NO. 1**

---

**SUBJECT: Panel assembly, Radar No. 14**

**CANCELLATION**

**INTRODUCTION**

1     AESP 2350-T-251-811 Mod Instr No. 1, EMER E107/2 Mod Instr 100 is hereby cancelled. This modification was applicable to equipment that has been declared obsolete, and is therefore no longer required.

**ACTION**

- 2     Amend AESP 2350-T-251-811 Mod Instr 1, EMER E107/2 modification index accordingly.
- 3     File this Page 1/2 in place of Mod Instr No. 100 dated Dec 75, all pages of which are to be destroyed.

**CONDITIONS OF RELEASE**

- |   |   |   |   |
|---|---|---|---|
| 1 | This information is released by the UK Government for Defence purposes only.  | 3 | This information may be disclosed only within the Defence Department of the recipient Government, except as otherwise authorized by Ministry of Defence (Army). |
| 2 | This information must be afforded the same degree of protection as that afforded to information of an equivalent security marking originated by the recipient Government or as required by the recipient Government's security regulations. | 4 | This information may be subject to privately owned rights.  |

THIS DOCUMENT IS THE PROPERTY OF HER BRITANNIC MAJESTY'S GOVERNMENT, and is issued for the information of such persons only as need to know its contents in the course of their official duties. Any person finding this document should hand it to a British forces unit or to a police station for its safe return to the MINISTRY OF DEFENCE (Dsy (Pol)), MAIN BUILDING, WHITEHALL, LONDON SW1A 2HB with particulars of how and where found. THE UNAUTHORIZED RETENTION OR DESTRUCTION OF THIS DOCUMENT MAY BE AN OFFENCE UNDER THE OFFICIAL SECRETS ACTS OF 1911-1989. (When released to persons outside Government service, this document is issued on a personal basis and the recipient to whom it may be entrusted in confidence, within the provision of the Official Secrets Acts 1911-1989, is personally responsible for its safe custody and for seeing that its contents are disclosed only to authorized persons).

**CARRIER, PERSONNEL, FULL TRACKED, FV 432 MK 2 AND 2/1**

**MODIFICATION INSTRUCTION NO. 1**

**SUBJECT: Winch, Miser mount**

**CANCELLATION**

**INTRODUCTION**

1 AESP 2350-T-251-811 Mod Instr No. 1, EMER E107/2 Mod Instr 101 is hereby cancelled. This modification was applicable to equipment that has been declared obsolete, and is therefore no longer required.

**ACTION**

2 Amend AESP 2350-T-251-811 Mod Instr 1, EMER E107/2 modification index accordingly.

3 File this Page 1/2 in place of Mod Instr No. 101 dated May 79, all pages of which are to be destroyed.

**CONDITIONS OF RELEASE**

- |   |   |   |   |
|---|---|---|---|
| 1 | This information is released by the UK Government for Defence purposes only.  | 3 | This information may be disclosed only within the Defence Department of the recipient Government, except as otherwise authorized by Ministry of Defence (Army). |
| 2 | This information must be afforded the same degree of protection as that afforded to information of an equivalent security marking originated by the recipient Government or as required by the recipient Government's security regulations. | 4 | This information may be subject to privately owned rights.  |

THIS DOCUMENT IS THE PROPERTY OF HER BRITANNIC MAJESTY'S GOVERNMENT, and is issued for the information of such persons only as need to know its contents in the course of their official duties. Any person finding this document should hand it to a British forces unit or to a police station for its safe return to the MINISTRY OF DEFENCE (Dsy (Pol)), MAIN BUILDING, WHITEHALL, LONDON SW1A 2HB with particulars of how and where found. THE UNAUTHORIZED RETENTION OR DESTRUCTION OF THIS DOCUMENT MAY BE AN OFFENCE UNDER THE OFFICIAL SECRETS ACTS OF 1911-1989. (When released to persons outside Government service, this document is issued on a personal basis and the recipient to whom it may be entrusted in confidence, within the provision of the Official Secrets Acts 1911-1989, is personally responsible for its safe custody and for seeing that its contents are disclosed only to authorized persons).

**CARRIER, PERSONNEL, FULL TRACKED, FV 432 MK 2 AND 2/1**

**MODIFICATION INSTRUCTION NO. 1**

**SUBJECT: Rarden turret, rotary base junction**

**CANCELLATION**

**INTRODUCTION**

1 AESP 2350-T-251-811 Mod Instr No. 1, EMER E107/2 Mod Instr 102 is hereby cancelled. This modification was applicable to equipment that has been declared obsolete, and is therefore no longer required.

**ACTION**

- 2 Amend AESP 2350-T-251-811 Mod Instr 1, EMER E107/2 modification index accordingly.
- 3 File this Page 1/2 in place of Mod Instr No. 102 dated Jan 76, all pages of which are to be destroyed.

**CONDITIONS OF RELEASE**

- |   |   |   |   |
|---|---|---|---|
| 1 | This information is released by the UK Government for Defence purposes only.  | 3 | This information may be disclosed only within the Defence Department of the recipient Government, except as otherwise authorized by Ministry of Defence (Army). |
| 2 | This information must be afforded the same degree of protection as that afforded to information of an equivalent security marking originated by the recipient Government or as required by the recipient Government's security regulations. | 4 | This information may be subject to privately owned rights.  |

THIS DOCUMENT IS THE PROPERTY OF HER BRITANNIC MAJESTY'S GOVERNMENT, and is issued for the information of such persons only as need to know its contents in the course of their official duties. Any person finding this document should hand it to a British forces unit or to a police station for its safe return to the MINISTRY OF DEFENCE (Dsy (Pol)), MAIN BUILDING, WHITEHALL, LONDON SW1A 2HB with particulars of how and where found. THE UNAUTHORIZED RETENTION OR DESTRUCTION OF THIS DOCUMENT MAY BE AN OFFENCE UNDER THE OFFICIAL SECRETS ACTS OF 1911-1989. (When released to persons outside Government service, this document is issued on a personal basis and the recipient to whom it may be entrusted in confidence, within the provision of the Official Secrets Acts 1911-1989, is personally responsible for its safe custody and for seeing that its contents are disclosed only to authorized persons).

**CARRIER, PERSONNEL, FULL TRACKED, FV432 MK 2 AND 2/1  
MODIFICATION INSTRUCTION NO. 1 (EMER TV E107/2 Mod Instr No.103)**

**SUBJECT: Collector tank, access hatch fitting**

**CANCELLATION**

**INTRODUCTION**

- 1 AESP 2350-T-251-811 Mod Instr No. 1, EMER TV E107 Mod Instr No.103 dated Mar 76 is hereby cancelled. The details of this modification have been incorporated into the build standard.

**ACTION**

- 2 Amend AESP 2350-T-251-811 Mod Instr No.1, EMER TV E107/2 modification index accordingly
- 3 File this Page 1/2 in place of Mod Instr No. 103 dated Mar 76, all pages of which are to be destroyed.

**CONDITIONS OF RELEASE**

- |   |   |   |   |
|---|---|---|---|
| 1 | This information is released by the UK Government for Defence purposes only.  | 3 | This information may be disclosed only within the Defence Department of the recipient Government, except as otherwise authorized by Ministry of Defence (Army). |
| 2 | This information must be afforded the same degree of protection as that afforded to information of an equivalent security marking originated by the recipient Government or as required by the recipient Government's security regulations. | 4 | This information may be subject to privately owned rights.  |

THIS DOCUMENT IS THE PROPERTY OF HER BRITANNIC MAJESTY'S GOVERNMENT, and is issued for the information of such persons only as need to know its contents in the course of their official duties. Any person finding this document should hand it to a British forces unit or to a police station for its safe return to the MINISTRY OF DEFENCE (Dsy (Pol)), MAIN BUILDING, WHITEHALL, LONDON SW1A 2HB with particulars of how and where found. THE UNAUTHORIZED RETENTION OR DESTRUCTION OF THIS DOCUMENT MAY BE AN OFFENCE UNDER THE OFFICIAL SECRETS ACTS OF 1911-1989. (When released to persons outside Government service, this document is issued on a personal basis and the recipient to whom it may be entrusted in confidence, within the provision of the Official Secrets Acts 1911-1989, is personally responsible for its safe custody and for seeing that its contents are disclosed only to authorized persons).

**CARRIER, PERSONNEL, FULL TRACKED, FV432 MK 2 AND 2/1  
MODIFICATION INSTRUCTION NO. 1 (EMER TV E107/2 Mod Instr No.104)**

**SUBJECT: Mortar mount**

**CANCELLATION**

**INTRODUCTION**

- 1 AESP 2350-T-251-811 Mod Instr No. 1, EMER TV E107 Mod Instr No.104 dated Oct 76 is hereby cancelled. The details of this modification have been incorporated into the build standard.

**ACTION**

- 2 Amend AESP 2350-T-251-811 Mod Instr No.1, EMER TV E107/2 modification index accordingly
- 3 File this Page 1/2 in place of Mod Instr No. 104 dated Oct 76, all pages of which are to be destroyed.



CONDITIONS OF RELEASE

- |  |  |
|--|--|
| 1. This information is released by the UK Government to the recipient Government for Defence purposes only.                | 3. This information may be disclosed only within the Defence Department of the recipient Government, except as otherwise authorized by Ministry of Defence (Army). |
| 2. This information must be accorded the same degree of security protection as that accorded thereto by the UK Government. | 4. This information may be subject to privately owned rights.  |

CARRIER, PERSONNEL, FULL TRACKED, (AMBULANCE ROLE ONLY)

FV 432 MK 1, 1/1, 2 and 2/1

TECHNICAL HANDBOOK -- MODIFICATION INSTRUCTION

Note: This issue 2 upersedes issue 1 dated Nov 76, the Nato stock number of harness has been added.

SUBJECT: Casualty harness - fitting of cleats

INTRODUCTION

1. a. Cleats are to be welded to the inside of the hull to provide anchorage for fitting casualty harnesses.
- b. Units are to demand the additional harness when the modification is carried out and hold them as part of the Ambulance conversion, CES No 34926.
- c. The CES will be amended and re-issued at a later date.

APPLICABILITY

2. Subject vehicles fitted for stretcher and seat role. Basic vehicles (Code Nos 0400.0110, 0400.0111, 0400.0112, 0400.0013) held by user units.      0040              0040              0040              0040

REASON FOR MODIFICATION

3. Code 1 - to improve safety

PRIORITY

4. Routine

ESTIMATED TIME REQUIRED

5. Embodiment:              2 man-hours  
Manufacturing:            2 man-hours

MODIFICATION IMPLEMENTATION PLAN

6. a. This modification is to be carried out in accordance with ARMY GENERAL ADMINISTRATIVE INSTRUCTIONS (AGAI) Chapter 90, Section II by units authorized to carry out field or base repairs.

Action required by:

7. a. Units and establishments holding equipment

- (1) Examine vehicle to see if modification is applicable.
- (2) If applicable request REME to modify equipment.
- (3) Record the Subject, EMER number, and Army Modification Code in equipment documents.
- (4) After modification demand harness detailed at para 8.b. and add to CES No 34926.

b. Units authorized to carry out field or base repairs

- (1) When requested by units obtain the items listed in para 8.a. and carry out this modification.
- (2) Record completion details of modification against appropriate entry in equipment documents.
- (3) Complete AF G1084A (Mgmt J 020 refers) when reporting completion of the modification to Data Centre. For the FORWARD coding refer to EMER Mgmt J 022.

ARMY MODIFICATION CODE J 01005

c. All recipients of this EMER

Add particulars to Tkd Vehs E 107/2 Mod Instr Index.

Stores, tools and equipment

8. a. Stores to be obtained locally for basic vehicle modification

<u>COSA</u> <u>Section</u>	<u>Part No</u>	<u>Designation</u>	<u>Qty per</u> <u>eqpt</u>
G2	9510-99-960-5900	Steel, mild, $\frac{1}{4}$ in. dia	1 lb

b. Stores to be obtained locally and added to CES 34926

9ACR	2540-99-819-1494	Harness sitting casualty r.h. (FV 743801)	3
9ACR	2540-99-819-1495	Harness sitting casualty l.h. (FV 743816)	2
9ACR	2540-99-821-1277	Restraint harness (FV 650106)	4

Sequence of operations

9. a. See Fig 1. Manufacture cleats (Qty 11) from material listed in para 8.a.
- b. Observe normal fire precautions for welding within a vehicle.
- c. See Fig 2. Remove padding to allow cleats to be welded in position.
- d. After welding cut padding to fit around cleats and refit padding.

Units holding vehicle

10. Demand harness detailed at para 8.b. and add to Ambulance conversion CES No 34926.

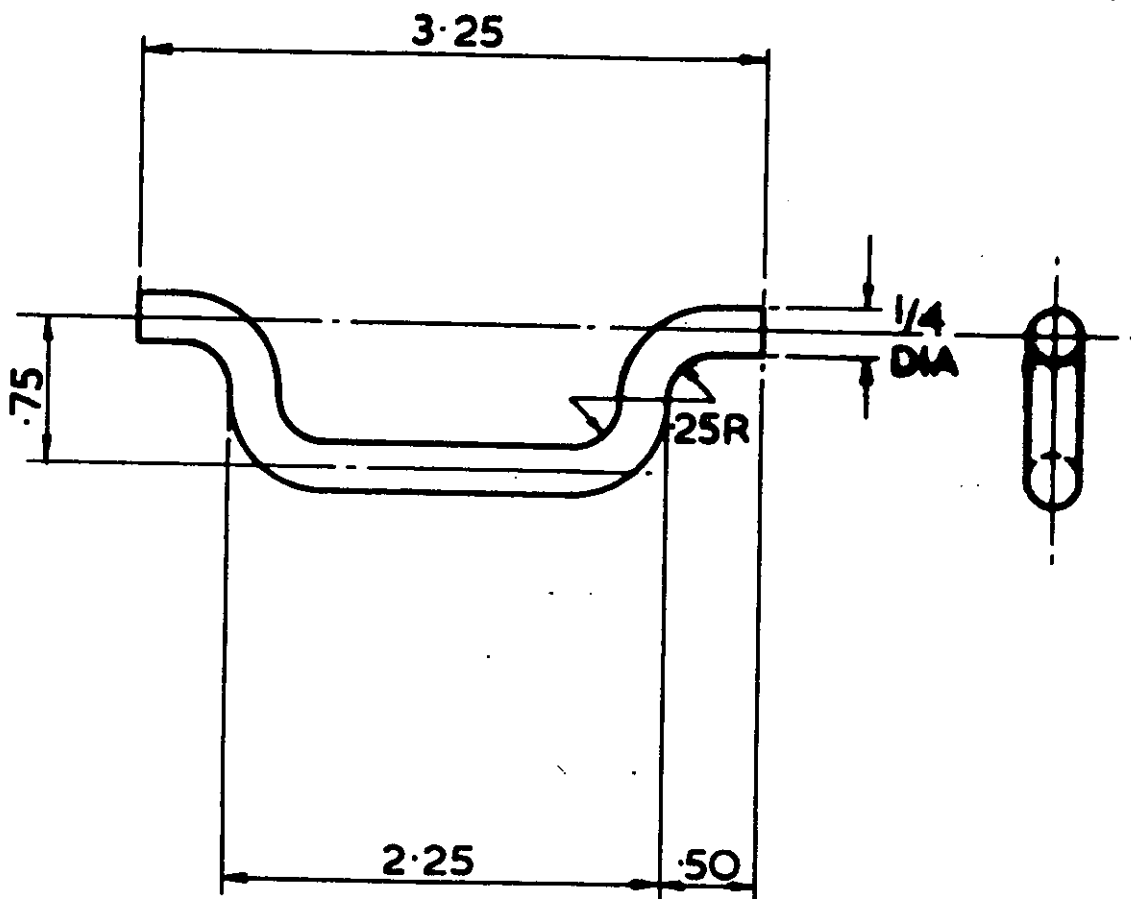

Fig 1 - Cleat manufacturing detail  
(Dimensions in inches)

V631/2

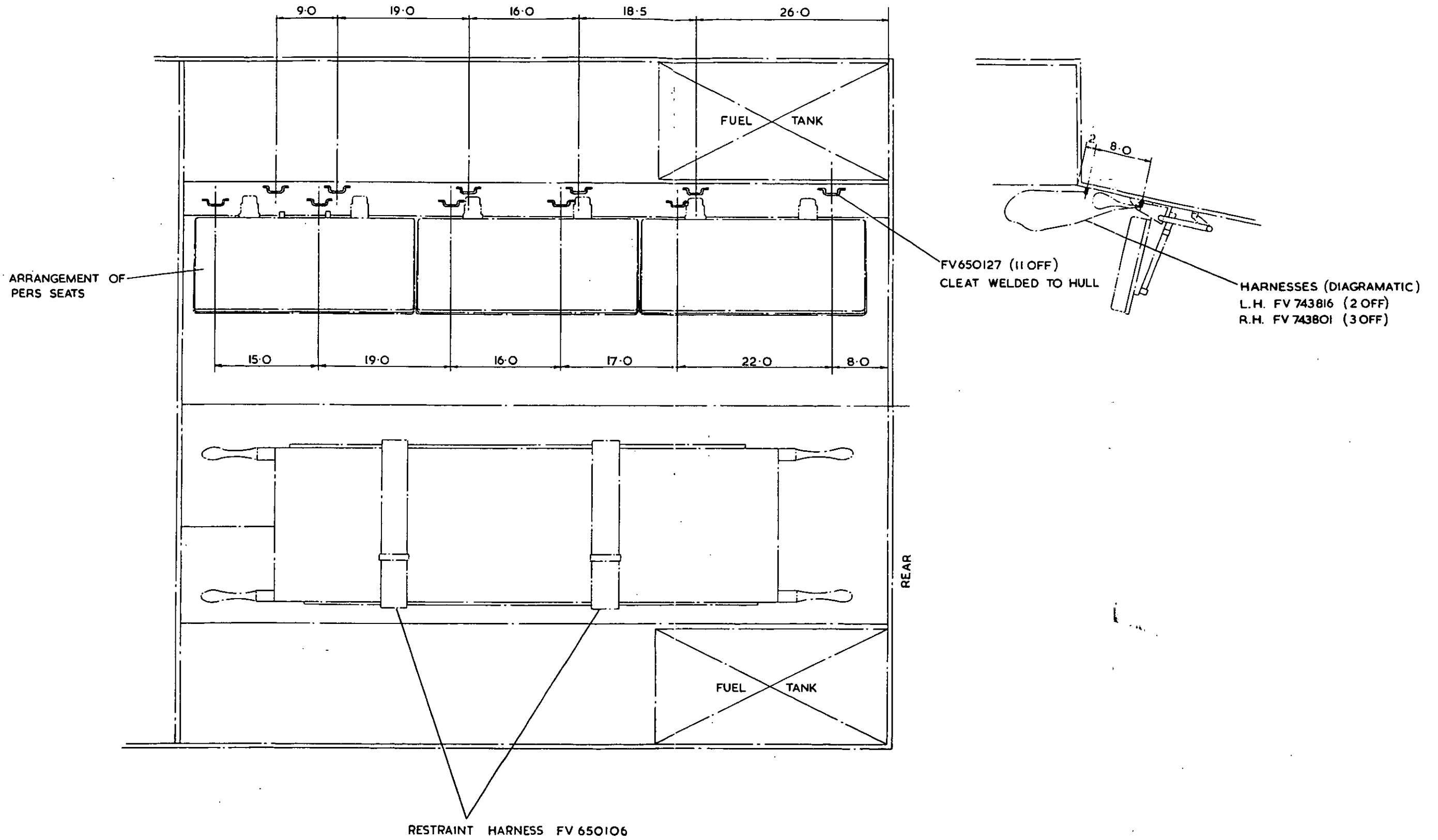

Fig 2 - Cleat welding details  
(Dimensions in inches)

END

CONDITIONS OF RELEASE

- |   |   |
|---|---|
| 1 This information is released by the UK Government for Defence purposes only.  | 3 This information may be disclosed only within the Defence Department of the recipient Government, except as otherwise authorized by Ministry of Defence (Army). |
| 2 This information must be afforded the same degree of protection as that afforded to information of an equivalent security marking originated by the recipient Government or as required by the recipient Government's security regulations. | 4 This information may be subject to privately owned rights.  |

THIS DOCUMENT IS THE PROPERTY OF HER BRITANNIC MAJESTY'S GOVERNMENT, and is issued for the information of such persons only as need to know its contents in the course of their official duties. Any person finding this document should hand it to a British forces unit or to a police station for its safe return to the MINISTRY OF DEFENCE (Dsy (Pol)), MAIN BUILDING, WHITEHALL, LONDON SW1A 2HB with particulars of how and where found. THE UNAUTHORIZED RETENTION OR DESTRUCTION OF THIS DOCUMENT MAY BE AN OFFENCE UNDER THE OFFICIAL SECRETS ACTS OF 1911-1989. (When released to persons outside Government service, this document is issued on a personal basis and the recipient to whom it may be entrusted in confidence, within the provision of the Official Secrets Acts 1911-1989, is personally responsible for its safe custody and for seeing that its contents are disclosed only to authorized persons).

**CARRIER, PERSONNEL, FULL TRACKED, FV 432 MK 2 AND 2/1**

**MODIFICATION INSTRUCTION NO. 1**

**SUBJECT: Rarden turret, night sight shroud**

**CANCELLATION**

**INTRODUCTION**

1 AESP 2350-T-251-811 Mod Instr No. 1, EMER E107/2 Mod Instr 106 is hereby cancelled. This modification was applicable to equipment that has been declared obsolete, and is therefore no longer required.

**ACTION**

- 2 Amend AESP 2350-T-251-811 Mod Instr 1, EMER E107/2 modification index accordingly.
- 3 File this Page 1/2 in place of Mod Instr No. 106 dated Dec 76, all pages of which are to be destroyed.

**CONDITIONS OF RELEASE**

- |   |   |
|---|---|
| 1 This information is released by the UK Government for Defence purposes only.  | 3 This information may be disclosed only within the Defence Department of the recipient Government, except as otherwise authorized by Ministry of Defence (Army). |
| 2 This information must be afforded the same degree of protection as that afforded to information of an equivalent security marking originated by the recipient Government or as required by the recipient Government's security regulations. | 4 This information may be subject to privately owned rights.  |

THIS DOCUMENT IS THE PROPERTY OF HER BRITANNIC MAJESTY'S GOVERNMENT, and is issued for the information of such persons only as need to know its contents in the course of their official duties. Any person finding this document should hand it to a British forces unit or to a police station for its safe return to the MINISTRY OF DEFENCE (Dsy (Pol)), MAIN BUILDING, WHITEHALL, LONDON SW1A 2HB with particulars of how and where found. THE UNAUTHORIZED RETENTION OR DESTRUCTION OF THIS DOCUMENT MAY BE AN OFFENCE UNDER THE OFFICIAL SECRETS ACTS OF 1911-1989. (When released to persons outside Government service, this document is issued on a personal basis and the recipient to whom it may be entrusted in confidence, within the provision of the Official Secrets Acts 1911-1989, is personally responsible for its safe custody and for seeing that its contents are disclosed only to authorized persons).

**CARRIER, PERSONNEL, FULL TRACKED, FV 432 MK 2 AND 2/1**

**MODIFICATION INSTRUCTION NO. 1**

---

**SUBJECT: Rarden turret, map light**

**CANCELLATION**

**INTRODUCTION**

1 AESP 2350-T-251-811 Mod Instr No. 1, EMER E107/2 Mod Instr 107 is hereby cancelled. This modification was applicable to equipment that has been declared obsolete, and is therefore no longer required.

**ACTION**

- 2 Amend AESP 2350-T-251-811 Mod Instr 1, EMER E107/2 modification index accordingly.
- 3 File this Page 1/2 in place of Mod Instr No. 107 dated Feb 77, all pages of which are to be destroyed.

**CONDITIONS OF RELEASE**

- |   |   |
|---|---|
| 1 This information is released by the UK Government for Defence purposes only.  | 3 This information may be disclosed only within the Defence Department of the recipient Government, except as otherwise authorized by Ministry of Defence (Army). |
| 2 This information must be afforded the same degree of protection as that afforded to information of an equivalent security marking originated by the recipient Government or as required by the recipient Government's security regulations. | 4 This information may be subject to privately owned rights.  |

THIS DOCUMENT IS THE PROPERTY OF HER BRITANNIC MAJESTY'S GOVERNMENT, and is issued for the information of such persons only as need to know its contents in the course of their official duties. Any person finding this document should hand it to a British forces unit or to a police station for its safe return to the MINISTRY OF DEFENCE (Dsy (Pol)), MAIN BUILDING, WHITEHALL, LONDON SW1A 2HB with particulars of how and where found. THE UNAUTHORIZED RETENTION OR DESTRUCTION OF THIS DOCUMENT MAY BE AN OFFENCE UNDER THE OFFICIAL SECRETS ACTS OF 1911-1989. (When released to persons outside Government service, this document is issued on a personal basis and the recipient to whom it may be entrusted in confidence, within the provision of the Official Secrets Acts 1911-1989, is personally responsible for its safe custody and for seeing that its contents are disclosed only to authorized persons).

**CARRIER, PERSONNEL, FULL TRACKED, FV 432 MK 2 AND 2/1**

**MODIFICATION INSTRUCTION NO. 1**

---

**SUBJECT: Rarden turret, night sight shroud door catch**

**CANCELLATION**

**INTRODUCTION**

1 AESP 2350-T-251-811 Mod Instr No. 1, EMER E107/2 Mod Instr 108 is hereby cancelled. This modification was applicable to equipment that has been declared obsolete, and is therefore no longer required.

**ACTION**

- 2 Amend AESP 2350-T-251-811 Mod Instr 1, EMER E107/2 modification index accordingly.
- 3 File this Page 1/2 in place of Mod Instr No. 108 dated Jul 77, all pages of which are to be destroyed.



CONDITIONS OF RELEASE

- |   |   |
|---|---|
| 1 This information is released by the UK Government for Defence purposes only.  | 3 This information may be disclosed only within the Defence Department of the recipient Government, except as otherwise authorized by Ministry of Defence (Army). |
| 2 This information must be afforded the same degree of protection as that afforded to information of an equivalent security marking originated by the recipient Government or as required by the recipient Government's security regulations. | 4 This information may be subject to privately owned rights.  |

THIS DOCUMENT IS THE PROPERTY OF HER BRITANNIC MAJESTY'S GOVERNMENT, and is issued for the information of such persons only as need to know its contents in the course of their official duties. Any person finding this document should hand it to a British forces unit or to a police station for its safe return to the MINISTRY OF DEFENCE (Dsy (Pol)), MAIN BUILDING, WHITEHALL, LONDON SW1A 2HB with particulars of how and where found. THE UNAUTHORIZED RETENTION OR DESTRUCTION OF THIS DOCUMENT MAY BE AN OFFENCE UNDER THE OFFICIAL SECRETS ACTS OF 1911-1989. (When released to persons outside Government service, this document is issued on a personal basis and the recipient to whom it may be entrusted in confidence, within the provision of the Official Secrets Acts 1911-1989, is personally responsible for its safe custody and for seeing that its contents are disclosed only to authorized persons).

**CARRIER, PERSONNEL, FULL TRACKED, FV 432 MK 2 AND 2/1**

**MODIFICATION INSTRUCTION NO. 1**

**SUBJECT: Rarden turret, commanders hatch**

**CANCELLATION**

**INTRODUCTION**

1 AESP 2350-T-251-811 Mod Instr No. 1, EMER E107/2 Mod Instr 109 is hereby cancelled. This modification was applicable to equipment that has been declared obsolete, and is therefore no longer required.

**ACTION**

- 2 Amend AESP 2350-T-251-811 Mod Instr 1, EMER E107/2 modification index accordingly.
- 3 File this Page 1/2 in place of Mod Instr No. 109 dated Jul 78, all pages of which are to be destroyed.

**CONDITIONS OF RELEASE**

- |   |   |
|---|---|
| 1 This information is released by the UK Government for Defence purposes only.  | 3 This information may be disclosed only within the Defence Department of the recipient Government, except as otherwise authorized by Ministry of Defence (Army). |
| 2 This information must be afforded the same degree of protection as that afforded to information of an equivalent security marking originated by the recipient Government or as required by the recipient Government's security regulations. | 4 This information may be subject to privately owned rights.  |

THIS DOCUMENT IS THE PROPERTY OF HER BRITANNIC MAJESTY'S GOVERNMENT, and is issued for the information of such persons only as need to know its contents in the course of their official duties. Any person finding this document should hand it to a British forces unit or to a police station for its safe return to the MINISTRY OF DEFENCE (Dsy (Pol)), MAIN BUILDING, WHITEHALL, LONDON SW1A 2HB with particulars of how and where found. THE UNAUTHORIZED RETENTION OR DESTRUCTION OF THIS DOCUMENT MAY BE AN OFFENCE UNDER THE OFFICIAL SECRETS ACTS OF 1911-1989. (When released to persons outside Government service, this document is issued on a personal basis and the recipient to whom it may be entrusted in confidence, within the provision of the Official Secrets Acts 1911-1989, is personally responsible for its safe custody and for seeing that its contents are disclosed only to authorized persons).

**CARRIER, PERSONNEL, FULL TRACKED, FV 432 MK 2 AND 2/1**

**MODIFICATION INSTRUCTION NO. 1**

---

**SUBJECT: Rarden turret, GPMG harness**

**CANCELLATION**

**INTRODUCTION**

1 AESP 2350-T-251-811 Mod Instr No. 1, EMER E107/2 Mod Instr 110 is hereby cancelled. This modification was applicable to equipment that has been declared obsolete, and is therefore no longer required.

**ACTION**

- 2 Amend AESP 2350-T-251-811 Mod Instr 1, EMER E107/2 modification index accordingly.
- 3 File this Page 1/2 in place of Mod Instr No. 110 dated Aug 78, all pages of which are to be destroyed.

**CONDITIONS OF RELEASE**

- |   |   |
|---|---|
| 1 This information is released by the UK Government for Defence purposes only.  | 3 This information may be disclosed only within the Defence Department of the recipient Government, except as otherwise authorized by Ministry of Defence (Army). |
| 2 This information must be afforded the same degree of protection as that afforded to information of an equivalent security marking originated by the recipient Government or as required by the recipient Government's security regulations. | 4 This information may be subject to privately owned rights.  |

THIS DOCUMENT IS THE PROPERTY OF HER BRITANNIC MAJESTY'S GOVERNMENT, and is issued for the information of such persons only as need to know its contents in the course of their official duties. Any person finding this document should hand it to a British forces unit or to a police station for its safe return to the MINISTRY OF DEFENCE (Dsy (Pol)), MAIN BUILDING, WHITEHALL, LONDON SW1A 2HB with particulars of how and where found. THE UNAUTHORIZED RETENTION OR DESTRUCTION OF THIS DOCUMENT MAY BE AN OFFENCE UNDER THE OFFICIAL SECRETS ACTS OF 1911-1989. (When released to persons outside Government service, this document is issued on a personal basis and the recipient to whom it may be entrusted in confidence, within the provision of the Official Secrets Acts 1911-1989, is personally responsible for its safe custody and for seeing that its contents are disclosed only to authorized persons).

**CARRIER, PERSONNEL, FULL TRACKED, FV 432 MK 2 AND 2/1**

**MODIFICATION INSTRUCTION NO. 1**

---

**SUBJECT: Rarden turret, commanders hatch stop**

**CANCELLATION**

**INTRODUCTION**

1 AESP 2350-T-251-811 Mod Instr No. 1, EMER E107/2 Mod Instr 111 is hereby cancelled. This modification was applicable to equipment that has been declared obsolete, and is therefore no longer required.

**ACTION**

- 2 Amend AESP 2350-T-251-811 Mod Instr 1, EMER E107/2 modification index accordingly.
- 3 File this Page 1/2 in place of Mod Instr No. 111 dated Aug 78, all pages of which are to be destroyed.

**CONDITIONS OF RELEASE**

- |   |   |
|---|---|
| 1 This information is released by the UK Government for Defence purposes only.  | 3 This information may be disclosed only within the Defence Department of the recipient Government, except as otherwise authorized by Ministry of Defence (Army). |
| 2 This information must be afforded the same degree of protection as that afforded to information of an equivalent security marking originated by the recipient Government or as required by the recipient Government's security regulations. | 4 This information may be subject to privately owned rights.  |

THIS DOCUMENT IS THE PROPERTY OF HER BRITANNIC MAJESTY'S GOVERNMENT, and is issued for the information of such persons only as need to know its contents in the course of their official duties. Any person finding this document should hand it to a British forces unit or to a police station for its safe return to the MINISTRY OF DEFENCE (Dsy (Pol)), MAIN BUILDING, WHITEHALL, LONDON SW1A 2HB with particulars of how and where found. THE UNAUTHORIZED RETENTION OR DESTRUCTION OF THIS DOCUMENT MAY BE AN OFFENCE UNDER THE OFFICIAL SECRETS ACTS OF 1911-1989. (When released to persons outside Government service, this document is issued on a personal basis and the recipient to whom it may be entrusted in confidence, within the provision of the Official Secrets Acts 1911-1989, is personally responsible for its safe custody and for seeing that its contents are disclosed only to authorized persons).

**CARRIER, PERSONNEL, FULL TRACKED, FV 432 MK 2 AND 2/1**

**MODIFICATION INSTRUCTION NO. 1**

**SUBJECT: GPMG turret, seat belt harness**

**CANCELLATION**

**INTRODUCTION**

1 AESP 2350-T-251-811 Mod Instr No. 1, EMER E107/2 Mod Instr 112 is hereby cancelled. This modification was applicable to equipment that has been declared obsolete, and is therefore no longer required.

**ACTION**

- 2 Amend AESP 2350-T-251-811 Mod Instr 1, EMER E107/2 modification index accordingly.
- 3 File this Page 1/2 in place of Mod Instr No. 112 dated Dec 78, all pages of which are to be destroyed.

**CONDITIONS OF RELEASE**

- |   |   |
|---|---|
| 1 This information is released by the UK Government for Defence purposes only.  | 3 This information may be disclosed only within the Defence Department of the recipient Government, except as otherwise authorized by Ministry of Defence (Army). |
| 2 This information must be afforded the same degree of protection as that afforded to information of an equivalent security marking originated by the recipient Government or as required by the recipient Government's security regulations. | 4 This information may be subject to privately owned rights.  |

THIS DOCUMENT IS THE PROPERTY OF HER BRITANNIC MAJESTY'S GOVERNMENT, and is issued for the information of such persons only as need to know its contents in the course of their official duties. Any person finding this document should hand it to a British forces unit or to a police station for its safe return to the MINISTRY OF DEFENCE (Dsy (Pol)), MAIN BUILDING, WHITEHALL, LONDON SW1A 2HB with particulars of how and where found. THE UNAUTHORIZED RETENTION OR DESTRUCTION OF THIS DOCUMENT MAY BE AN OFFENCE UNDER THE OFFICIAL SECRETS ACTS OF 1911-1989. (When released to persons outside Government service, this document is issued on a personal basis and the recipient to whom it may be entrusted in confidence, within the provision of the Official Secrets Acts 1911-1989, is personally responsible for its safe custody and for seeing that its contents are disclosed only to authorized persons).

**CARRIER, PERSONNEL, FULL TRACKED, FV 432 MK 2 AND 2/1**

**MODIFICATION INSTRUCTION NO. 1**

**SUBJECT: Rarden turret, associated mods**

**CANCELLATION**

**INTRODUCTION**

1 AESP 2350-T-251-811 Mod Instr No. 1, EMER E107/2 Mod Instr 113 is hereby cancelled. This modification was applicable to equipment that has been declared obsolete, and is therefore no longer required.

**ACTION**

- 2 Amend AESP 2350-T-251-811 Mod Instr 1, EMER E107/2 modification index accordingly.
- 3 File this Page 1/2 in place of Mod Instr No. 113 dated Aug 78, all pages of which are to be destroyed.

**CONDITIONS OF RELEASE**

- |   |   |
|---|---|
| 1 This information is released by the UK Government for Defence purposes only.  | 3 This information may be disclosed only within the Defence Department of the recipient Government, except as otherwise authorized by Ministry of Defence (Army). |
| 2 This information must be afforded the same degree of protection as that afforded to information of an equivalent security marking originated by the recipient Government or as required by the recipient Government's security regulations. | 4 This information may be subject to privately owned rights.  |

THIS DOCUMENT IS THE PROPERTY OF HER BRITANNIC MAJESTY'S GOVERNMENT, and is issued for the information of such persons only as need to know its contents in the course of their official duties. Any person finding this document should hand it to a British forces unit or to a police station for its safe return to the MINISTRY OF DEFENCE (Dsy (Pol)), MAIN BUILDING, WHITEHALL, LONDON SW1A 2HB with particulars of how and where found. THE UNAUTHORIZED RETENTION OR DESTRUCTION OF THIS DOCUMENT MAY BE AN OFFENCE UNDER THE OFFICIAL SECRETS ACTS OF 1911-1989. (When released to persons outside Government service, this document is issued on a personal basis and the recipient to whom it may be entrusted in confidence, within the provision of the Official Secrets Acts 1911-1989, is personally responsible for its safe custody and for seeing that its contents are disclosed only to authorized persons).

**CARRIER, PERSONNEL, FULL TRACKED, FV432 MK 2 AND 2/1  
MODIFICATION INSTRUCTION NO. 1 (EMER TV E107/2 Mod Instr No.114)**

**SUBJECT: Strengthening of commanders seat pillar**

**CANCELLATION**

**INTRODUCTION**

- 1 AESP 2350-T-251-811 Mod Instr No. 1, EMER TV E107 Mod Instr No.114 dated Jan 84 is hereby cancelled. The details of this modification have been incorporated into the build standard.

**ACTION**

- 2 Amend AESP 2350-T-251-811 Mod Instr No.1, EMER TV E107/2 modification index accordingly
- 3 File this Page 1/2 in place of Mod Instr No. 114 dated Jan 84, all pages of which are to be destroyed.

CONDITIONS OF RELEASE

- |  |  |
|--|--|
| 1. This information is released by the UK Government to the recipient Government for Defence purposes only.                | 3. This information may be disclosed only within the Defence Department of the recipient Government, except as otherwise authorized by Ministry of Defence (Army). |
| 2. This information must be accorded the same degree of security protection as that accorded thereto by the UK Government. | 4. This information may be subject to privately owned rights.  |

CARRIER, FULL TRACKED, FV 432 MK 2 AND 2/1, FV 438 AND FV 439 MK 2/1

TECHNICAL HANDBOOK - MODIFICATION INSTRUCTION

Errata

Note: This Page 0 is to be filed immediately in front of Page 1.

Amend as follows:

Issue 1, Page 2, para 8.a.

Delete Item 3 in entirety.

Insert New Item 3 as follows:

<u>COSA</u> <u>Section</u>	<u>NSN/Part No</u>	<u>Designation</u>	<u>Qty per</u> <u>eqpt</u>
H9	5330-99-120-7071	Rubber sheet (natural)	1 ft x 3/4 in. w

70411 (144)  
Veh Br ALM/FVO/7/TSS 1501  
Data Centre Code FVF7A

CONDITIONS OF RELEASE

- |  |  |
|--|--|
| 1. This information is released by the UK Government to the recipient Government for Defence purpose only.                 | 3. This information may be disclosed only within the Defence Department of the recipient Government, except as otherwise authorized by Ministry of Defence (Army). |
| 2. This information must be accorded the same degree of security protection as that accorded thereto by the UK Government. | 4. This information may be subject to privately owned rights.  |

CARRIER, FULL TRACKED, FV432 MK 2 AND 2/1, FV438 AND FV439 MK 2/1

TECHNICAL HANDBOOK - MODIFICATION INSTRUCTION

SUBJECT: Engine compartment rear cover

INTRODUCTION

1. The top l.h. corner of the rear compartment cover is made detachable to give access to power pack l.h. rear mounting without removing the complete cover.

APPLICABILITY

2. Engine compartment rear cover, FV 560100 fitted to subject vehicles (Code Nos 0040.0111, 0040.0112, 0040.2111, 0040.2112, 0740.0180, 0750.0172, 0760.0172, 0765.0172) held by user units.

REASON FOR MODIFICATION

3. Code 4 - to improve maintainability

PRIORITY

4. Routine

ESTIMATED TIME REQUIRED

5. Manufacturing: 1.0 man-hour. To be carried out during 2500 mile service or when the cover is removed.

MODIFICATION IMPLEMENTATION PLAN

6. This modification is to be carried out by units authorized to carry out unit, field or base repairs.

Action required by:

7. a. Units and establishments holding equipment

Record the Subject, EMER number and Army Modification Code in equipment documents.

b. Units authorized to carry out unit, field or base repairs

(1) During service or when cover is removed for any reason, obtain the items listed in para 8.a. and carry out this modification.

(2) Record completion details of modification against appropriate entry in equipment documents.



7. b. (3) Complete AF G1084A (Mgmt J O20 refers) when reporting completion of the modification to Data Centre. For Equipment Code refer to Mgmt J O22.

ARMY MODIFICATION CODE: J 01490

- c. All recipients of this EMER

Add particulars to Tkd Veh E 107/2 Mod Instr Index.

Stores, tools and equipment

8. a. Stores to be obtained locally

<u>Item No</u>	<u>COSA Section</u>	<u>NSN/Part No</u>	<u>Designation</u>	<u>Qty per eqpt</u>
1	G1	5310-99-944-0550	Washer, lock 3/8 in. i.d. x 0.590 in. o.d. x 0.092 in. thk	3
2	G1	5305-99-941-0538	Screw, machine 3/8 in. x 5/8 in. lg UNF	3
3	H9	<sup>5330</sup> <del>5320-99-120-7097</del> <sup>7071</sup>	Rubber <sup>SHEET</sup> strip, (natural) <del>3/4 in.</del> <del>w x 1/8 in. thk</del>	1 ft x <sup>3/4</sup> in. W
4	G2	9515-99-960-6065	Steel strip, carbon, hot rolled 1/8 in. x 1 in.	1 ft
5	G1	5310-99-107-2391	Nut, hex UNF 3/8 in. x 21/64 in. o/a h	3

- b. Stores to be modified

6		FV 560100	Cover plate	1
---	--	-----------	-------------	---

Sequence of operations

9. See Fig 1 for all details.
- Cut off corner of cover plate
  - Mark off and drill three holes in main cover plate.
  - Position and braze three captive nuts on to rear face of cover.
  - Weld extra strips of metal to cut off corner piece.
  - Mark off and drill three 13/32 in. holes in modified corner section.
  - During assembly the corner plate should be sealed properly using strip rubber (item 3).

Testing after embodiment

10. NA

EMER AMENDMENTS

11. Tkd Veh E 103/2, Chap 1, para 26.

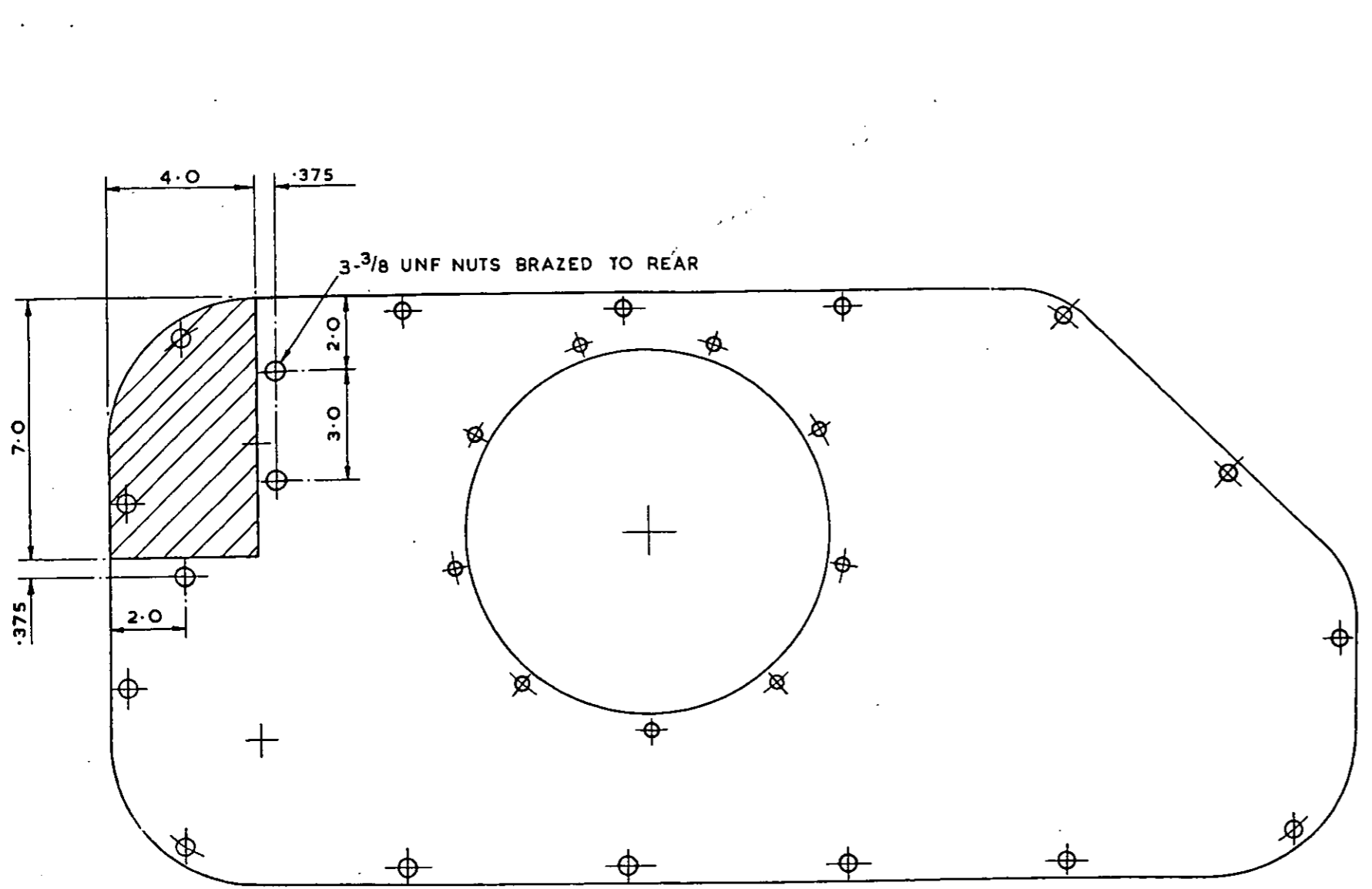

SHADED AREA TO BE CUT OUT  
& RETAINED

TOL ±0.01

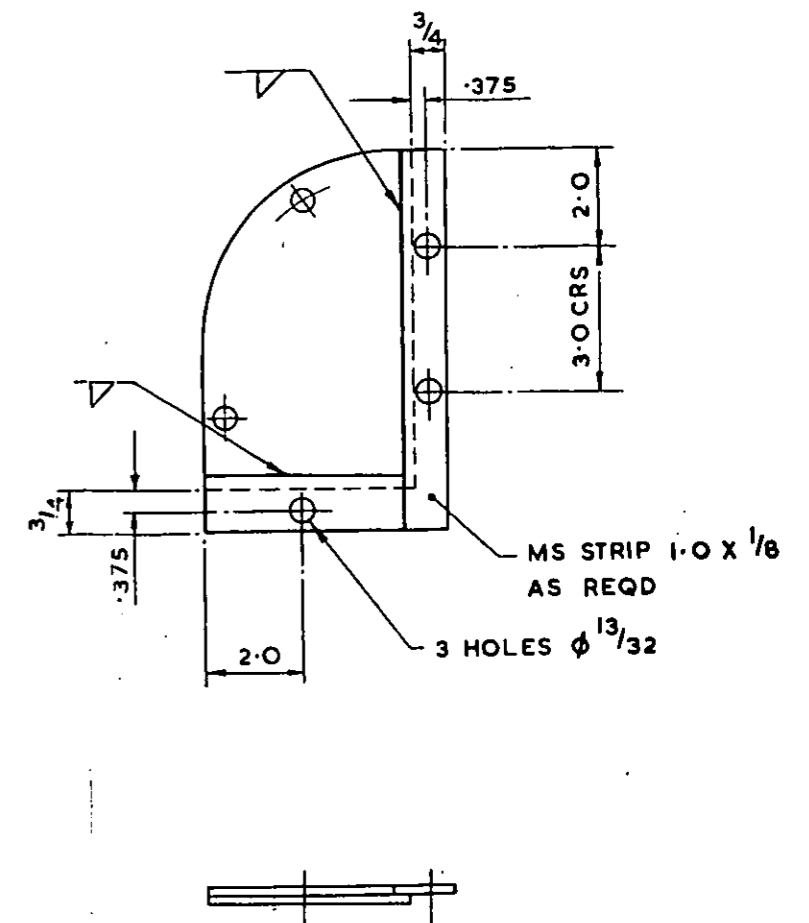

MODIFIED SEGMENT

NOTE:-  
RE ASSEMBLE USING RUBBER SEALING STRIP  
& 3/8 UNF HEX HD SCREWS (GI-5305-99-941-0538)  
(3 OFF)

BRAZE IN ACCORDANCE WITH EMER WORKSHOPS O-360  
SYMBOLS TO BS 499 PT 2

Fig 1 - Cover plate (cross bulkhead)

END

CONDITIONS OF RELEASE

- |  |  |
|--|--|
| 1. This information is released by the UK Government to the recipient Government for Defence purposes only.                | 3. This information may be disclosed only within the Defence Department of the recipient Government, except as otherwise authorised by Ministry of Defence (Army). |
| 2. This information must be accorded the same degree of security protection as that accorded thereto by the UK Government. | 4. This information may be subject to privately owned rights.  |

THIS DOCUMENT IS THE PROPERTY OF HER BRITANNIC MAJESTY'S GOVERNMENT, and is issued for the information of such persons only as need to know its contents in the course of their official duties. Any person finding this document should hand it into a British forces unit or to a police station for its safe return to the MINISTRY OF DEFENCE D.MOD Sy LONDON SW1A 2HB with particulars of how and where found. THE UNAUTHORISED RETENTION OR DESTRUCTION OF THE DOCUMENT IS AN OFFENCE UNDER THE OFFICIAL SECRETS ACTS OF 1911 - 1939. (When released to persons outside Government service, this document is issued on a personal basis and the recipient to whom it is entrusted in confidence within the provision of the Official Secrets Acts 1911 - 1939, is personally responsible for its safe custody and for seeing that its contents are disclosed only to authorised persons).

CARRIER, PERSONNEL, FULL TRACKED Mk 1, 1/1, 2 and 2/1 (FV432)

TECHNICAL HANDBOOK - MODIFICATION INSTRUCTION

Note ...

This issue 3, pages 1-5/6 supersedes issue 2 pages 1-6 dated Nov 83. The regulation has been revised.

SUBJECT: Ventilation batteries

INTRODUCTION

1 To enable the vehicle to be used in various roles, an alternative location for ventilation batteries is provided.

APPLICABILITY

2 Hull floor fitted to FV 432 Mk 1, Mk 2 and 2/1 vehicles (Code No 0041.3000, 0041.3002, 0040.0111, 0040.2111, 0040.3000, 0040.0112, 0040.2112, 0040.3001, 0045.1112 and 0045.3000) held by user units.

REASON FOR MODIFICATION

3 Code 2 - to improve operational performance.

PRIORITY

4 Routine

ESTIMATED TIME REQUIRED

5 Stripping and assembling: 1 man-hour  
Manufacturing: 2 man-hours

MODIFICATION IMPLEMENTATION PLAN

6

6.1 This modification is to be implemented by units authorised to carry out unit, field or base repairs.

6.2 Modification plate strike action: NA

Action required by:

7

7.1 Units and establishments holding equipment

Note ...

When authorised by MOD (Army).

7.1.1 Examine equipment documents to see if modification is applicable.

7.1.2 Examine equipment to see if modification is embodied and where necessary demand the stores required.

7.1.3 On receipt of stores, request REME to modify equipment.

7.1.4 Record the modification Subject, EMER number and Modification Code in equipment documents.

7.2 Units authorized to carry out unit, field or base repairs

7.2.1 When requested by users or during overhaul, obtain the items listed in para 8 and carry out this modification instruction.

7.2.2 Record completion details of modification against appropriate entry in equipment documents.

7.2.3 Complete AF G1084A when reporting completion of the modification to Data Centre using the following FORWARD codes:

EQUIPMENT CODE: Refer to para 2  
MODIFICATION CODE: NN0000

7.3 All recipients of this instruction. Add particulars to EMER Tracked Vehicles, E107/2 Mod Instr Index.

Stores, tools and equipment

8

8.1 Stores or suitable equivalent to be obtained locally

<u>Item No</u>	<u>COSA Section</u>	<u>NSN/Part No</u>	<u>Designation</u>	<u>Qty per eqpt</u>
1	G2 X	9510-99-960-5784	Steel bar, flat 16½in. lg	4½ lb
OR ALTERNATIVE				
30mm x 120mm	G2 ✓ x42	9510-99-964-6958	Steel, bar, flat 420mm lg	2½ kg
X2	G1	5310-99-135-8383	Nut, plain, welding, 1/4 UNF	2

<u>Item No</u>	<u>COSA Section</u>	<u>NSN/Part No</u>	<u>Designation</u>	<u>Qty per eqpt</u>
3	6MT4	5340-99-805-0929	'P' clip, 1/2in. dia	3
4	6MT4	5340-99-408-0890	'P' clip, 5/8in. dia	5
5	G1	5305-99-941-0510	Screw, 1/4 UNF x 1/4in. lg	2
6	G1	5310-99-970-3050	Washer, flat, 1/4in.	7
7	G1	5310-99-941-6654	Washer, spring, 1/4in.	2
8	6MT4	2940-99-193-6331	Terminal, battery positive	1

Sequence of operations

Note ...

Numbers in brackets refer to items listed in para 8 of this instruction.  
All drawing dimensions are in inches.

9 Carry out the modification as follows:

9.1 Manufacture blocks as detailed in Fig 1.

9.2 Position and weld blocks to vehicle floor as detailed in Fig 2.

9.3 Secure battery frame and negative earthing cable to blocks using existing screws and washers.

Refer to Fig 3

9.4 Gain access to area indicated and using commanders seat rear mounting bolts as a datum, mark out and cut 2 holes in the lining panel to safely permit welding on of nuts (2).

9.5 Disconnect/remove battery breather pipe. Turn roof outlet 180° and refit/reroute pipe, following the existing cable run along the roof to the RH wall continuing down to the batteries on the hull floor. Secure pipe to dividing plate and weld nut (2) using both existing, and new items (3), (5), (6) and (7). Discard unused items.

9.6 Reroute battery positive cable via the RH hull wall to the batteries on the hull floor as shown, using existing mounting bolts and new items (2), (4), (5), (6) and (7).

9.7 Cut cable to length and solder on positive terminal (8).

Testing after embodiment

10 Nil

EFFECT ON WEIGHT

11 Negligible

PUBLICATION AMENDMENTS

12 Nil

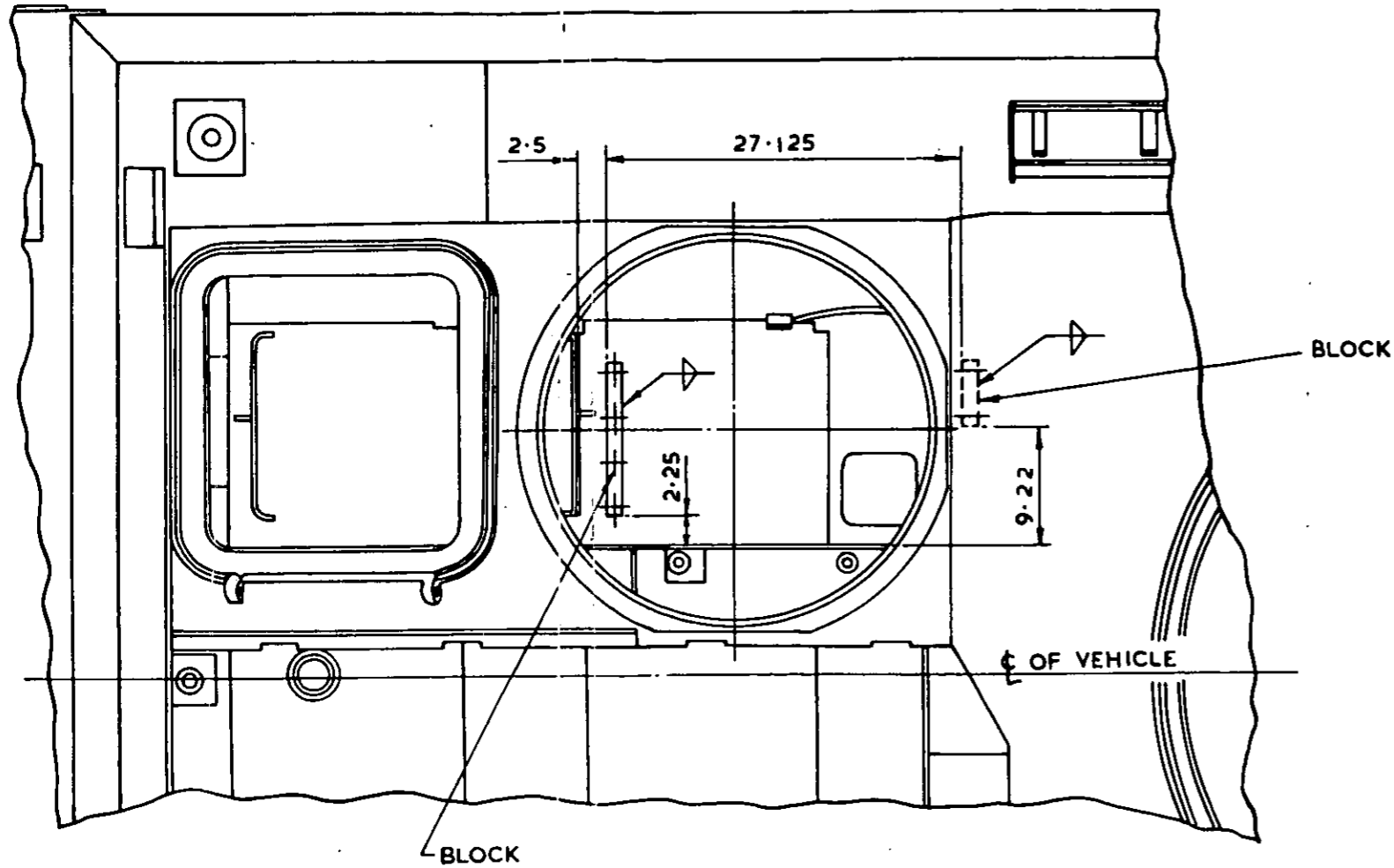

WELD IN ACCORDANCE WITH EMER WORKSHOPS  
O-360 SYMBOLS TO BS 499 Pt 2

V4538/1

Fig 2 Hull - welding positions  
(Dimensions in inches)

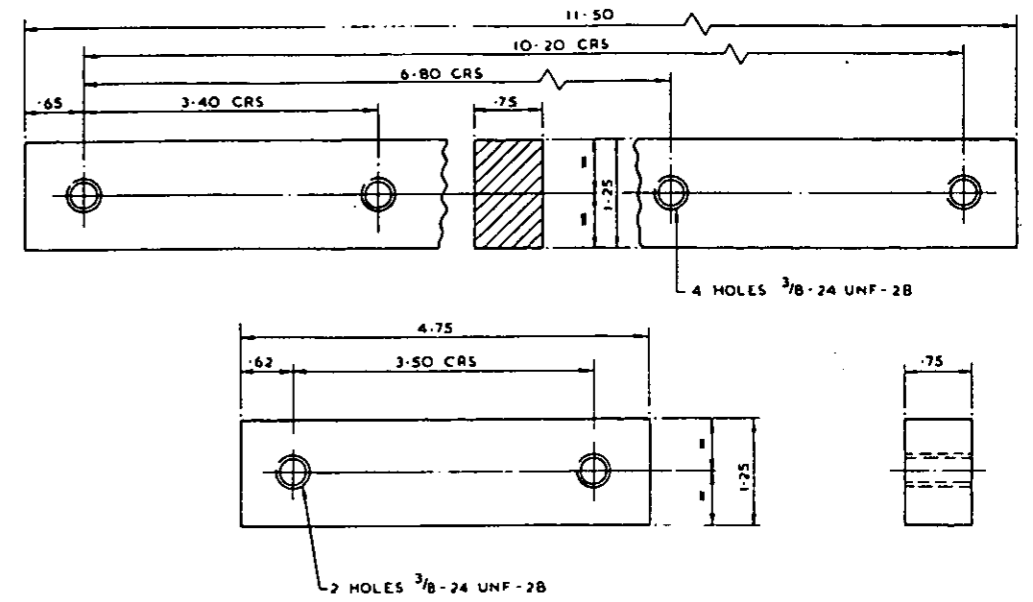

V4538/2

Fig 1 Blocks (Dimensions in inches)

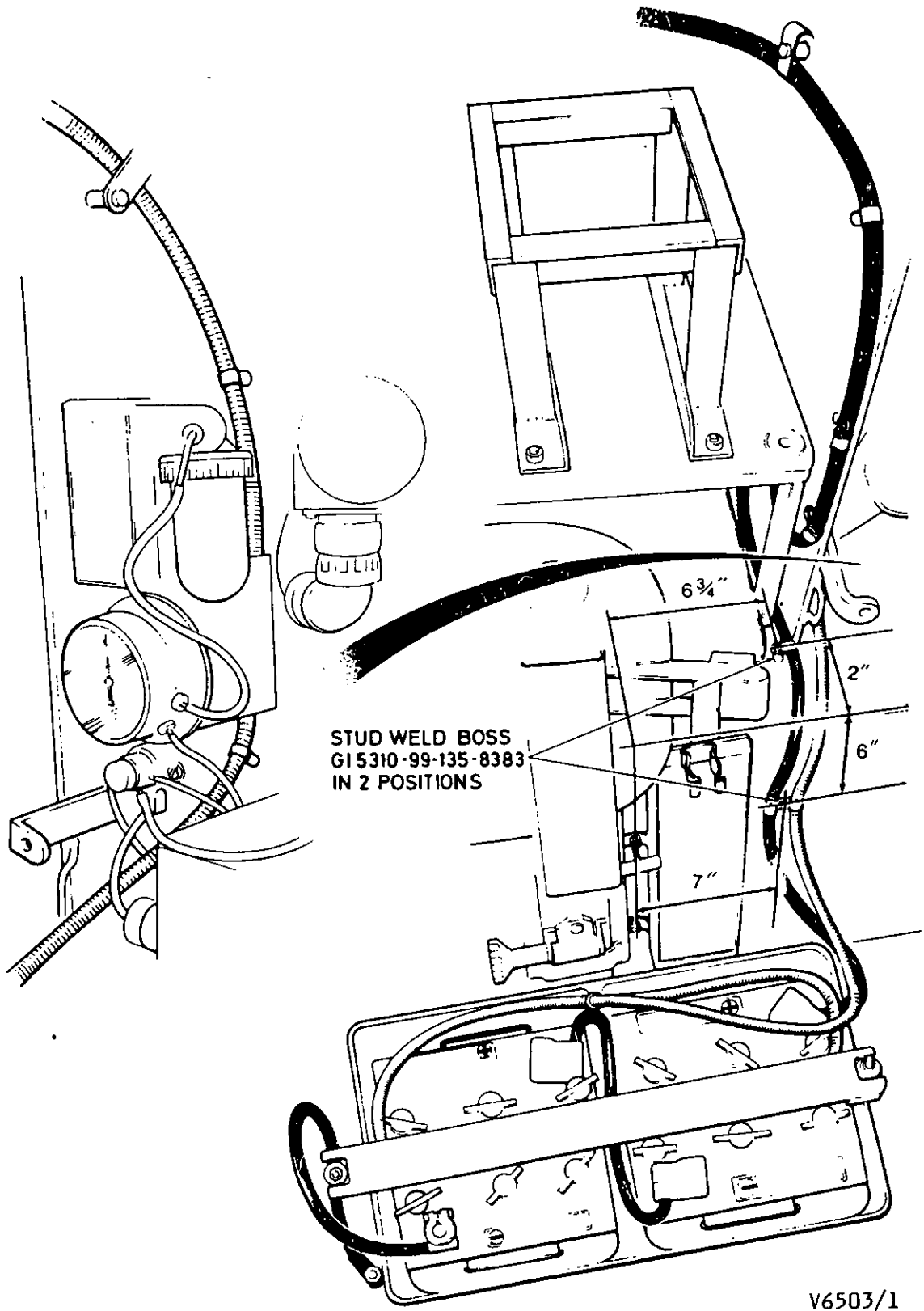

Fig 3 Battery and cable orientation  
(Dimensions in inches)

**CONDITIONS OF RELEASE**

- |   |   |
|---|---|
| 1 This information is released by the UK Government for Defence purposes only.  | 3 This information may be disclosed only within the Defence Department of the recipient Government, except as otherwise authorized by Ministry of Defence (Army). |
| 2 This information must be afforded the same degree of protection as that afforded to information of an equivalent security marking originated by the recipient Government or as required by the recipient Government's security regulations. | 4 This information may be subject to privately owned rights.  |

THIS DOCUMENT IS THE PROPERTY OF HER BRITANNIC MAJESTY'S GOVERNMENT, and is issued for the information of such persons only as need to know its contents in the course of their official duties. Any person finding this document should hand it to a British forces unit or to a police station for its safe return to the MINISTRY OF DEFENCE (Dsy (Pol)), MAIN BUILDING, WHITEHALL, LONDON SW1A 2HB with particulars of how and where found. THE UNAUTHORIZED RETENTION OR DESTRUCTION OF THIS DOCUMENT MAY BE AN OFFENCE UNDER THE OFFICIAL SECRETS ACTS OF 1911-1989. (When released to persons outside Government service, this document is issued on a personal basis and the recipient to whom it may be entrusted in confidence, within the provision of the Official Secrets Acts 1911-1989, is personally responsible for its safe custody and for seeing that its contents are disclosed only to authorized persons).

**CARRIER, PERSONNEL, FULL TRACKED, FV 432 MK 2 AND 2/1**

**MODIFICATION INSTRUCTION NO. 1**

**SUBJECT: Rarden turret, adapter ring**

**CANCELLATION**

**INTRODUCTION**

1 AESP 2350-T-251-811 Mod Instr No. 1, EMER E107/2 Mod Instr 117 is hereby cancelled. This modification was applicable to equipment that has been declared obsolete, and is therefore no longer required.

**ACTION**

- 2 Amend AESP 2350-T-251-811 Mod Instr 1, EMER E107/2 modification index accordingly.
- 3 File this Page 1/2 in place of Mod Instr No. 117 dated Jun 79, all pages of which are to be destroyed.



**CONDITIONS OF RELEASE**

- |   |   |
|---|---|
| 1 This information is released by the UK Government for Defence purposes only.  | 3 This information may be disclosed only within the Defence Department of the recipient Government, except as otherwise authorized by Ministry of Defence (Army). |
| 2 This information must be afforded the same degree of protection as that afforded to information of an equivalent security marking originated by the recipient Government or as required by the recipient Government's security regulations. | 4 This information may be subject to privately owned rights.  |

THIS DOCUMENT IS THE PROPERTY OF HER BRITANNIC MAJESTY'S GOVERNMENT, and is issued for the information of such persons only as need to know its contents in the course of their official duties. Any person finding this document should hand it to a British forces unit or to a police station for its safe return to the MINISTRY OF DEFENCE (Dsy (Pol)), MAIN BUILDING, WHITEHALL, LONDON SW1A 2HB with particulars of how and where found. THE UNAUTHORIZED RETENTION OR DESTRUCTION OF THIS DOCUMENT MAY BE AN OFFENCE UNDER THE OFFICIAL SECRETS ACTS OF 1911-1989. (When released to persons outside Government service, this document is issued on a personal basis and the recipient to whom it may be entrusted in confidence, within the provision of the Official Secrets Acts 1911-1989, is personally responsible for its safe custody and for seeing that its contents are disclosed only to authorized persons).

**CARRIER, PERSONNEL, FULL TRACKED, FV432 MK 2 AND 2/1  
MODIFICATION INSTRUCTION NO. 1 (EMER TV E107/2 Mod Instr No.118)**

**SUBJECT: Weapon tray/rack (internal stowage)**

**CANCELLATION**

**INTRODUCTION**

- 1 AESP 2350-T-251-811 Mod Instr No. 1, EMER TV E107 Mod Instr No.118 dated Jul 79 is hereby cancelled. The weapons related to this modification are no longer issued..

**ACTION**

- 2 Amend AESP 2350-T-251-811 Mod Instr No.1, EMER TV E107/2 modification index accordingly
- 3 File this Page 1/2 in place of Mod Instr No. 118 dated Jul 79, all pages of which are to be destroyed.

**CONDITIONS OF RELEASE**

- |   |   |
|---|---|
| 1 This information is released by the UK Government for Defence purposes only.  | 3 This information may be disclosed only within the Defence Department of the recipient Government, except as otherwise authorized by Ministry of Defence (Army). |
| 2 This information must be afforded the same degree of protection as that afforded to information of an equivalent security marking originated by the recipient Government or as required by the recipient Government's security regulations. | 4 This information may be subject to privately owned rights.  |

THIS DOCUMENT IS THE PROPERTY OF HER BRITANNIC MAJESTY'S GOVERNMENT, and is issued for the information of such persons only as need to know its contents in the course of their official duties. Any person finding this document should hand it to a British forces unit or to a police station for its safe return to the MINISTRY OF DEFENCE (Dsy (Pol)), MAIN BUILDING, WHITEHALL, LONDON SW1A 2HB with particulars of how and where found. THE UNAUTHORIZED RETENTION OR DESTRUCTION OF THIS DOCUMENT MAY BE AN OFFENCE UNDER THE OFFICIAL SECRETS ACTS OF 1911-1989. (When released to persons outside Government service, this document is issued on a personal basis and the recipient to whom it may be entrusted in confidence, within the provision of the Official Secrets Acts 1911-1989, is personally responsible for its safe custody and for seeing that its contents are disclosed only to authorized persons).

**CARRIER, PERSONNEL, FULL TRACKED, FV 432 MK 2 AND 2/1**

**MODIFICATION INSTRUCTION NO. 1**

**SUBJECT: GPMG turret, latch handle**

**CANCELLATION**

**INTRODUCTION**

1 AESP 2350-T-251-811 Mod Instr No. 1, EMER E107/2 Mod Instr 119 is hereby cancelled. This modification was applicable to equipment that has been declared obsolete, and is therefore no longer required.

**ACTION**

- 2 Amend AESP 2350-T-251-811 Mod Instr 1, EMER E107/2 modification index accordingly.
- 3 File this Page 1/2 in place of Mod Instr No. 119 dated Sep 79, all pages of which are to be destroyed.

**CONDITIONS OF RELEASE**

- |   |   |
|---|---|
| 1 This information is released by the UK Government for Defence purposes only.  | 3 This information may be disclosed only within the Defence Department of the recipient Government, except as otherwise authorized by Ministry of Defence (Army). |
| 2 This information must be afforded the same degree of protection as that afforded to information of an equivalent security marking originated by the recipient Government or as required by the recipient Government's security regulations. | 4 This information may be subject to privately owned rights.  |

THIS DOCUMENT IS THE PROPERTY OF HER BRITANNIC MAJESTY'S GOVERNMENT, and is issued for the information of such persons only as need to know its contents in the course of their official duties. Any person finding this document should hand it to a British forces unit or to a police station for its safe return to the MINISTRY OF DEFENCE (Dsy (Pol)), MAIN BUILDING, WHITEHALL, LONDON SW1A 2HB with particulars of how and where found. THE UNAUTHORIZED RETENTION OR DESTRUCTION OF THIS DOCUMENT MAY BE AN OFFENCE UNDER THE OFFICIAL SECRETS ACTS OF 1911-1989. (When released to persons outside Government service, this document is issued on a personal basis and the recipient to whom it may be entrusted in confidence, within the provision of the Official Secrets Acts 1911-1989, is personally responsible for its safe custody and for seeing that its contents are disclosed only to authorized persons).

**CARRIER, PERSONNEL, FULL TRACKED, FV 432 MK 2 AND 2/1**

**MODIFICATION INSTRUCTION NO. 1**

---

**SUBJECT: GPMG turret, padding on adapter plate**

**CANCELLATION**

**INTRODUCTION**

1 AESP 2350-T-251-811 Mod Instr No. 1, EMER E107/2 Mod Instr 120 is hereby cancelled. This modification was applicable to equipment that has been declared obsolete, and is therefore no longer required.

**ACTION**

- 2 Amend AESP 2350-T-251-811 Mod Instr 1, EMER E107/2 modification index accordingly.
- 3 File this Page 1/2 in place of Mod Instr No. 120 dated Dec 79, all pages of which are to be destroyed.

**CONDITIONS OF RELEASE**

- |   |   |   |   |
|---|---|---|---|
| 1 | This information is released by the UK Government for Defence purposes only.  | 3 | This information may be disclosed only within the Defence Department of the recipient Government, except as otherwise authorized by Ministry of Defence (Army). |
| 2 | This information must be afforded the same degree of protection as that afforded to information of an equivalent security marking originated by the recipient Government or as required by the recipient Government's security regulations. | 4 | This information may be subject to privately owned rights.  |

THIS DOCUMENT IS THE PROPERTY OF HER BRITANNIC MAJESTY'S GOVERNMENT, and is issued for the information of such persons only as need to know its contents in the course of their official duties. Any person finding this document should hand it to a British forces unit or to a police station for its safe return to the MINISTRY OF DEFENCE (Dsy (Pol)), MAIN BUILDING, WHITEHALL, LONDON SW1A 2HB with particulars of how and where found. THE UNAUTHORIZED RETENTION OR DESTRUCTION OF THIS DOCUMENT MAY BE AN OFFENCE UNDER THE OFFICIAL SECRETS ACTS OF 1911-1989. (When released to persons outside Government service, this document is issued on a personal basis and the recipient to whom it may be entrusted in confidence, within the provision of the Official Secrets Acts 1911-1989, is personally responsible for its safe custody and for seeing that its contents are disclosed only to authorized persons).

**CARRIER, PERSONNEL, FULL TRACKED, FV 432 MK 2 AND 2/1**

**MODIFICATION INSTRUCTION NO. 1**

---

**SUBJECT: GPMG turret, power wiper**

**CANCELLATION**

**INTRODUCTION**

1 AESP 2350-T-251-811 Mod Instr No. 1, EMER E107/2 Mod Instr 121 is hereby cancelled. This modification was applicable to equipment that has been declared obsolete, and is therefore no longer required.

**ACTION**

- 2 Amend AESP 2350-T-251-811 Mod Instr 1, EMER E107/2 modification index accordingly.
- 3 File this Page 1/2 in place of Mod Instr No. 121 dated Nov 80, all pages of which are to be destroyed.

**CONDITIONS OF RELEASE**

- |   |   |
|---|---|
| 1 This information is released by the UK Government for Defence purposes only.  | 3 This information may be disclosed only within the Defence Department of the recipient Government, except as otherwise authorized by Ministry of Defence (Army). |
| 2 This information must be afforded the same degree of protection as that afforded to information of an equivalent security marking originated by the recipient Government or as required by the recipient Government's security regulations. | 4 This information may be subject to privately owned rights.  |

THIS DOCUMENT IS THE PROPERTY OF HER BRITANNIC MAJESTY'S GOVERNMENT, and is issued for the information of such persons only as need to know its contents in the course of their official duties. Any person finding this document should hand it to a British forces unit or to a police station for its safe return to the MINISTRY OF DEFENCE (Dsy (Pol)), MAIN BUILDING, WHITEHALL, LONDON SW1A 2HB with particulars of how and where found. THE UNAUTHORIZED RETENTION OR DESTRUCTION OF THIS DOCUMENT MAY BE AN OFFENCE UNDER THE OFFICIAL SECRETS ACTS OF 1911-1989. (When released to persons outside Government service, this document is issued on a personal basis and the recipient to whom it may be entrusted in confidence, within the provision of the Official Secrets Acts 1911-1989, is personally responsible for its safe custody and for seeing that its contents are disclosed only to authorized persons).

**CARRIER, PERSONNEL, FULL TRACKED, FV 432 MK 2 AND 2/1**

**MODIFICATION INSTRUCTION NO. 1**

**SUBJECT: Exhaust system**

**CANCELLATION**

**INTRODUCTION**

1 AESP 2350-T-251-811 Mod Instr No. 1, EMER E107/2 Mod Instr 122 is hereby cancelled. This modification is applicable to Mk 1 vehicles only.

**ACTION**

- 2 Amend AESP 2350-T-251-811 Mod Instr 1, EMER E107/2 modification index accordingly.
- 3 File this Page 1/2 in place of Mod Instr No. 122 dated Oct 85, all pages of which are to be destroyed.

**CONDITIONS OF RELEASE**

- |   |   |
|---|---|
| 1 This information is released by the UK Government for Defence purposes only.  | 3 This information may be disclosed only within the Defence Department of the recipient Government, except as otherwise authorized by Ministry of Defence (Army). |
| 2 This information must be afforded the same degree of protection as that afforded to information of an equivalent security marking originated by the recipient Government or as required by the recipient Government's security regulations. | 4 This information may be subject to privately owned rights.  |

THIS DOCUMENT IS THE PROPERTY OF HER BRITANNIC MAJESTY'S GOVERNMENT, and is issued for the information of such persons only as need to know its contents in the course of their official duties. Any person finding this document should hand it to a British forces unit or to a police station for its safe return to the MINISTRY OF DEFENCE (Dsy (Pol)), MAIN BUILDING, WHITEHALL, LONDON SW1A 2HB with particulars of how and where found. THE UNAUTHORIZED RETENTION OR DESTRUCTION OF THIS DOCUMENT MAY BE AN OFFENCE UNDER THE OFFICIAL SECRETS ACTS OF 1911-1989. (When released to persons outside Government service, this document is issued on a personal basis and the recipient to whom it may be entrusted in confidence, within the provision of the Official Secrets Acts 1911-1989, is personally responsible for its safe custody and for seeing that its contents are disclosed only to authorized persons).

**CARRIER, PERSONNEL, FULL TRACKED, FV 432 MK 2 AND 2/1**

**MODIFICATION INSTRUCTION NO. 1**

**SUBJECT: Rarden turret, RH smoke discharger**

**CANCELLATION**

**INTRODUCTION**

1 AESP 2350-T-251-811 Mod Instr No. 1, EMER E107/2 Mod Instr 123 is hereby cancelled. This modification was applicable to equipment that has been declared obsolete, and is therefore no longer required.

**ACTION**

- 2 Amend AESP 2350-T-251-811 Mod Instr 1, EMER E107/2 modification index accordingly.
- 3 File this Page 1/2 in place of Mod Instr No. 123 dated Sep 81, all pages of which are to be destroyed.

**CONDITIONS OF RELEASE**

- |   |   |
|---|---|
| 1 This information is released by the UK Government for Defence purposes only.  | 3 This information may be disclosed only within the Defence Department of the recipient Government, except as otherwise authorized by Ministry of Defence (Army). |
| 2 This information must be afforded the same degree of protection as that afforded to information of an equivalent security marking originated by the recipient Government or as required by the recipient Government's security regulations. | 4 This information may be subject to privately owned rights.  |

THIS DOCUMENT IS THE PROPERTY OF HER BRITANNIC MAJESTY'S GOVERNMENT, and is issued for the information of such persons only as need to know its contents in the course of their official duties. Any person finding this document should hand it to a British forces unit or to a police station for its safe return to the MINISTRY OF DEFENCE (Dsy (Pol)), MAIN BUILDING, WHITEHALL, LONDON SW1A 2HB with particulars of how and where found. THE UNAUTHORIZED RETENTION OR DESTRUCTION OF THIS DOCUMENT MAY BE AN OFFENCE UNDER THE OFFICIAL SECRETS ACTS OF 1911-1989. (When released to persons outside Government service, this document is issued on a personal basis and the recipient to whom it may be entrusted in confidence, within the provision of the Official Secrets Acts 1911-1989, is personally responsible for its safe custody and for seeing that its contents are disclosed only to authorized persons).

**CARRIER, PERSONNEL, FULL TRACKED, FV 432 MK 2 AND 2/1**

**MODIFICATION INSTRUCTION NO. 1**

**SUBJECT: Jettison fuel tank removal**

**CANCELLATION**

**INTRODUCTION**

1 AESP 2350-T-251-811 Mod Instr No. 1, EMER E107/2 Mod Instr 124 is hereby cancelled. The details of this modification have been incorporated into the build standard.

**ACTION**

- 2 Amend AESP 2350-T-251-811 Mod Instr 1, EMER E107/2 modification index accordingly.
- 3 File this Page 1/2 in place of Mod Instr No. 124 dated Oct 81, all pages of which are to be destroyed.

**CONDITIONS OF RELEASE**

- |   |   |
|---|---|
| 1 This information is released by the UK Government for Defence purposes only.  | 3 This information may be disclosed only within the Defence Department of the recipient Government, except as otherwise authorized by Ministry of Defence (Army). |
| 2 This information must be afforded the same degree of protection as that afforded to information of an equivalent security marking originated by the recipient Government or as required by the recipient Government's security regulations. | 4 This information may be subject to privately owned rights.  |

THIS DOCUMENT IS THE PROPERTY OF HER BRITANNIC MAJESTY'S GOVERNMENT, and is issued for the information of such persons only as need to know its contents in the course of their official duties. Any person finding this document should hand it to a British forces unit or to a police station for its safe return to the MINISTRY OF DEFENCE (Dsy (Pol)), MAIN BUILDING, WHITEHALL, LONDON SW1A 2HB with particulars of how and where found. THE UNAUTHORIZED RETENTION OR DESTRUCTION OF THIS DOCUMENT MAY BE AN OFFENCE UNDER THE OFFICIAL SECRETS ACTS OF 1911-1989. (When released to persons outside Government service, this document is issued on a personal basis and the recipient to whom it may be entrusted in confidence, within the provision of the Official Secrets Acts 1911-1989, is personally responsible for its safe custody and for seeing that its contents are disclosed only to authorized persons).

**CARRIER, PERSONNEL, FULL TRACKED, FV432 MK 2 AND 2/1  
MODIFICATION INSTRUCTION NO. 1 (EMER TV E107/2 Mod Instr No.125)**

**SUBJECT: Conversion to accept PADS**

**CANCELLATION**

**INTRODUCTION**

- 1 AESP 2350-T-251-811 Mod Instr No. 1, EMER TV E107 Mod Instr No.125 dated Jun 83 is hereby cancelled. The detail contained within this modification instruction is no longer applicable.

**ACTION**

- 2 Amend AESP 2350-T-251-811 Mod Instr No.1, EMER TV E107/2 modification index accordingly
- 3 File this Page 1/2 in place of Mod Instr No. 125 dated Jun 83, all pages of which are to be destroyed.



**CONDITIONS OF RELEASE**

- |   |   |
|---|---|
| 1 This information is released by the UK Government for Defence purposes only.  | 3 This information may be disclosed only within the Defence Department of the recipient Government, except as otherwise authorized by Ministry of Defence (Army). |
| 2 This information must be afforded the same degree of protection as that afforded to information of an equivalent security marking originated by the recipient Government or as required by the recipient Government's security regulations. | 4 This information may be subject to privately owned rights.  |

THIS DOCUMENT IS THE PROPERTY OF HER BRITANNIC MAJESTY'S GOVERNMENT, and is issued for the information of such persons only as need to know its contents in the course of their official duties. Any person finding this document should hand it to a British forces unit or to a police station for its safe return to the MINISTRY OF DEFENCE (Dsy (Pol)), MAIN BUILDING, WHITEHALL, LONDON SW1A 2HB with particulars of how and where found. THE UNAUTHORIZED RETENTION OR DESTRUCTION OF THIS DOCUMENT MAY BE AN OFFENCE UNDER THE OFFICIAL SECRETS ACTS OF 1911-1989. (When released to persons outside Government service, this document is issued on a personal basis and the recipient to whom it may be entrusted in confidence, within the provision of the Official Secrets Acts 1911-1989, is personally responsible for its safe custody and for seeing that its contents are disclosed only to authorized persons).

**CARRIER, PERSONNEL, FULL TRACKED, FV432 MK 2 AND 2/1  
MODIFICATION INSTRUCTION NO. 1 (EMER TV E107/2 Mod Instr No 126)**

**SUBJECT: Conversion to accept Laser Range Finder (LRF) and Laser Target Marker (LTM)**

**CANCELLATION**

**INTRODUCTION**

- 1 AESP 2350-T-251-811 Mod Instr No. 1, EMER TV E107 Mod Instr No.126 dated Aug 90 is hereby cancelled. The details of this modification instruction are no longer applicable to this vehicle.

**ACTION**

- 2 Amend AESP 2350-T-251-811 Mod Instr No.1, EMER TV E107/2 modification index accordingly
- 3 File this Page 1/2 in place of Mod Instr No. 126 dated Aug 90, all pages of which are to be destroyed.

**CONDITIONS OF RELEASE**

- |   |   |   |   |
|---|---|---|---|
| 1 | This information is released by the UK Government for Defence purposes only.  | 3 | This information may be disclosed only within the Defence Department of the recipient Government, except as otherwise authorized by Ministry of Defence (Army). |
| 2 | This information must be afforded the same degree of protection as that afforded to information of an equivalent security marking originated by the recipient Government or as required by the recipient Government's security regulations. | 4 | This information may be subject to privately owned rights.  |

THIS DOCUMENT IS THE PROPERTY OF HER BRITANNIC MAJESTY'S GOVERNMENT, and is issued for the information of such persons only as need to know its contents in the course of their official duties. Any person finding this document should hand it to a British forces unit or to a police station for its safe return to the MINISTRY OF DEFENCE (Dsy (Pol)), MAIN BUILDING, WHITEHALL, LONDON SW1A 2HB with particulars of how and where found. THE UNAUTHORIZED RETENTION OR DESTRUCTION OF THIS DOCUMENT MAY BE AN OFFENCE UNDER THE OFFICIAL SECRETS ACTS OF 1911-1989. (When released to persons outside Government service, this document is issued on a personal basis and the recipient to whom it may be entrusted in confidence, within the provision of the Official Secrets Acts 1911-1989, is personally responsible for its safe custody and for seeing that its contents are disclosed only to authorized persons).

**CARRIER, PERSONNEL, FULL TRACKED, FV 432 MK 2 AND 2/1**

**MODIFICATION INSTRUCTION NO. 1**

**SUBJECT: Rarden turret, hatch catches**

**CANCELLATION**

**INTRODUCTION**

1 AESP 2350-T-251-811 Mod Instr No. 1, EMER E107/2 Mod Instr 127 is hereby cancelled. This modification was applicable to equipment that has been declared obsolete, and is therefore no longer required.

**ACTION**

- 2 Amend AESP 2350-T-251-811 Mod Instr 1, EMER E107/2 modification index accordingly.
- 3 File this Page 1/2 in place of Mod Instr No. 127 dated Feb 83, all pages of which are to be destroyed.

**CONDITIONS OF RELEASE**

- |   |   |
|---|---|
| 1 This information is released by the UK Government for Defence purposes only.  | 3 This information may be disclosed only within the Defence Department of the recipient Government, except as otherwise authorized by Ministry of Defence (Army). |
| 2 This information must be afforded the same degree of protection as that afforded to information of an equivalent security marking originated by the recipient Government or as required by the recipient Government's security regulations. | 4 This information may be subject to privately owned rights.  |

THIS DOCUMENT IS THE PROPERTY OF HER BRITANNIC MAJESTY'S GOVERNMENT, and is issued for the information of such persons only as need to know its contents in the course of their official duties. Any person finding this document should hand it to a British forces unit or to a police station for its safe return to the MINISTRY OF DEFENCE (Dsy (Pol)), MAIN BUILDING, WHITEHALL, LONDON SW1A 2HB with particulars of how and where found. THE UNAUTHORIZED RETENTION OR DESTRUCTION OF THIS DOCUMENT MAY BE AN OFFENCE UNDER THE OFFICIAL SECRETS ACTS OF 1911-1989. (When released to persons outside Government service, this document is issued on a personal basis and the recipient to whom it may be entrusted in confidence, within the provision of the Official Secrets Acts 1911-1989, is personally responsible for its safe custody and for seeing that its contents are disclosed only to authorized persons).

**CARRIER, PERSONNEL, FULL TRACKED, FV432 MK 2 AND 2/1  
MODIFICATION INSTRUCTION NO. 1 (EMER TV E107/2 Mod Instr No.128)**

**SUBJECT: Milan installation**

**CANCELLATION**

**INTRODUCTION**

- 1 AESP 2350-T-251-811 Mod Instr No. 1, EMER TV E107 Mod Instr No.128 dated Aug 86 is hereby cancelled. The weapon system related to this modification is no longer associated with FV432.

**ACTION**

- 2 Amend AESP 2350-T-251-811 Mod Instr No.1, EMER TV E107/2 modification index accordingly
- 3 File this Page 1/2 in place of Mod Instr No. 128 dated Aug 86, all pages of which are to be destroyed.

**CONDITIONS OF RELEASE**

- |   |   |
|---|---|
| 1 This information is released by the UK Government for Defence purposes only.  | 3 This information may be disclosed only within the Defence Department of the recipient Government, except as otherwise authorized by Ministry of Defence (Army). |
| 2 This information must be afforded the same degree of protection as that afforded to information of an equivalent security marking originated by the recipient Government or as required by the recipient Government's security regulations. | 4 This information may be subject to privately owned rights.  |

THIS DOCUMENT IS THE PROPERTY OF HER BRITANNIC MAJESTY'S GOVERNMENT, and is issued for the information of such persons only as need to know its contents in the course of their official duties. Any person finding this document should hand it to a British forces unit or to a police station for its safe return to the MINISTRY OF DEFENCE (Dsy (Pol)), MAIN BUILDING, WHITEHALL, LONDON SW1A 2HB with particulars of how and where found. THE UNAUTHORIZED RETENTION OR DESTRUCTION OF THIS DOCUMENT MAY BE AN OFFENCE UNDER THE OFFICIAL SECRETS ACTS OF 1911-1989. (When released to persons outside Government service, this document is issued on a personal basis and the recipient to whom it may be entrusted in confidence, within the provision of the Official Secrets Acts 1911-1989, is personally responsible for its safe custody and for seeing that its contents are disclosed only to authorized persons).

**CARRIER, PERSONNEL, FULL TRACKED, FV432 MK 2 AND 2/1  
MODIFICATION INSTRUCTION NO. 1 (EMER TV E107/2 Mod Instr No 129)**

**SUBJECT: NAIAD installation**

**CANCELLATION**

**INTRODUCTION**

- 1 AESP 2350-T-251-811 Mod Instr No. 1, EMER TV E107 Mod Instr No.129 dated Aug 85 is hereby cancelled. NAIAD has been declared obsolete.

**ACTION**

- 2 Amend AESP 2350-T-251-811 Mod Instr No.1, EMER TV E107/2 modification index accordingly
- 3 File this Page 1/2 in place of Mod Instr No. 129 dated Aug 85, all pages of which are to be destroyed.

**CONDITIONS OF RELEASE**

- |   |   |
|---|---|
| 1 This information is released by the UK Government for Defence purposes only.  | 3 This information may be disclosed only within the Defence Department of the recipient Government, except as otherwise authorized by Ministry of Defence (Army). |
| 2 This information must be afforded the same degree of protection as that afforded to information of an equivalent security marking originated by the recipient Government or as required by the recipient Government's security regulations. | 4 This information may be subject to privately owned rights.  |

THIS DOCUMENT IS THE PROPERTY OF HER BRITANNIC MAJESTY'S GOVERNMENT, and is issued for the information of such persons only as need to know its contents in the course of their official duties. Any person finding this document should hand it to a British forces unit or to a police station for its safe return to the MINISTRY OF DEFENCE (Dsy (Pol)), MAIN BUILDING, WHITEHALL, LONDON SW1A 2HB with particulars of how and where found. THE UNAUTHORIZED RETENTION OR DESTRUCTION OF THIS DOCUMENT MAY BE AN OFFENCE UNDER THE OFFICIAL SECRETS ACTS OF 1911-1989. (When released to persons outside Government service, this document is issued on a personal basis and the recipient to whom it may be entrusted in confidence, within the provision of the Official Secrets Acts 1911-1989, is personally responsible for its safe custody and for seeing that its contents are disclosed only to authorized persons).

**CARRIER, PERSONNEL, FULL TRACKED, FV432 MK 2 AND 2/1  
MODIFICATION INSTRUCTION NO. 1 (EMER TV E107/2 Mod Instr No.130)**

**SUBJECT: OTIS support**

**CANCELLATION**

**INTRODUCTION**

- 1 AESP 2350-T-251-811 Mod Instr No. 1, EMER TV E107 Mod Instr No.130 dated Nov 85 is hereby cancelled. The details of this modification have been incorporated into the build standard.

**ACTION**

- 2 Amend AESP 2350-T-251-811 Mod Instr No.1, EMER TV E107/2 modification index accordingly
- 3 File this Page 1/2 in place of Mod Instr No. 130 dated Nov 85, all pages of which are to be destroyed.

**CONDITIONS OF RELEASE**

- |   |   |
|---|---|
| 1 This information is released by the UK Government for Defence purposes only.  | 3 This information may be disclosed only within the Defence Department of the recipient Government, except as otherwise authorized by Ministry of Defence (Army). |
| 2 This information must be afforded the same degree of protection as that afforded to information of an equivalent security marking originated by the recipient Government or as required by the recipient Government's security regulations. | 4 This information may be subject to privately owned rights.  |

THIS DOCUMENT IS THE PROPERTY OF HER BRITANNIC MAJESTY'S GOVERNMENT, and is issued for the information of such persons only as need to know its contents in the course of their official duties. Any person finding this document should hand it to a British forces unit or to a police station for its safe return to the MINISTRY OF DEFENCE (Dsy (Pol)), MAIN BUILDING, WHITEHALL, LONDON SW1A 2HB with particulars of how and where found. THE UNAUTHORIZED RETENTION OR DESTRUCTION OF THIS DOCUMENT MAY BE AN OFFENCE UNDER THE OFFICIAL SECRETS ACTS OF 1911-1989. (When released to persons outside Government service, this document is issued on a personal basis and the recipient to whom it may be entrusted in confidence, within the provision of the Official Secrets Acts 1911-1989, is personally responsible for its safe custody and for seeing that its contents are disclosed only to authorized persons).

**CARRIER, PERSONNEL, FULL TRACKED, FV 432 MK 2 AND 2/1**

**MODIFICATION INSTRUCTION NO. 1**

**SUBJECT: Exhaust system**

**CANCELLATION**

**INTRODUCTION**

1 AESP 2350-T-251-811 Mod Instr No. 1, EMER E107/2 Mod Instr 131 is hereby cancelled. This modification is applicable to Mk 1 vehicles only.

**ACTION**

- 2 Amend AESP 2350-T-251-811 Mod Instr 1, EMER E107/2 modification index accordingly.
- 3 File this Page 1/2 in place of Mod Instr No. 131 dated Feb 86, all pages of which are to be destroyed.

CONDITIONS OF RELEASE

- |   |   |
|---|---|
| 1 This information is released by the UK Government for Defence purposes only.  | 3 This information may be disclosed only within the Defence Department of the recipient Government, except as otherwise authorized by Ministry of Defence (Army). |
| 2 This information must be afforded the same degree of protection as that afforded to information of an equivalent security marking originated by the recipient Government or as required by the recipient Government's security regulations. | 4 This information may be subject to privately owned rights.  |

THIS DOCUMENT IS THE PROPERTY OF HER BRITANNIC MAJESTY'S GOVERNMENT, and is issued for the information of such persons only as need to know its contents in the course of their official duties. Any person finding this document should hand it to a British forces unit or to a police station for its safe return to the MINISTRY OF DEFENCE (Dsy (Pol)), MAIN BUILDING, WHITEHALL, LONDON SW1A 2HB with particulars of how and where found. THE UNAUTHORIZED RETENTION OR DESTRUCTION OF THIS DOCUMENT MAY BE AN OFFENCE UNDER THE OFFICIAL SECRETS ACTS OF 1911-1989. (When released to persons outside Government service, this document is issued on a personal basis and the recipient to whom it may be entrusted in confidence, within the provision of the Official Secrets Acts 1911-1989, is personally responsible for its safe custody and for seeing that its contents are disclosed only to authorized persons).

**CARRIER, PERSONNEL, FULL TRACKED, FV 432 MK 2 AND 2/1**

**MODIFICATION INSTRUCTION NO. 1**

**SUBJECT: Rarden turret, gun crutch**

**CANCELLATION**

**INTRODUCTION**

1 AESP 2350-T-251-811 Mod Instr No. 1, EMER E107/2 Mod Instr 132 is hereby cancelled. This modification was applicable to equipment that has been declared obsolete, and is therefore no longer required.

**ACTION**

- 2 Amend AESP 2350-T-251-811 Mod Instr 1, EMER E107/2 modification index accordingly.
- 3 File this Page 1/2 in place of Mod Instr No. 132 dated Apr 86, all pages of which are to be destroyed.

CONDITIONS OF RELEASE

- |  |  |
|--|--|
| 1. This information is released by the UK Government to the recipient Government for Defence purposes only.                | 3. This information may be disclosed only within the Defence Department of the recipient Government, except as otherwise authorised by Ministry of Defence (Army). |
| 2. This information must be accorded the same degree of security protection as that accorded thereto by the UK Government. | 4. This information may be subject to privately owned rights.  |

THIS DOCUMENT IS THE PROPERTY OF HER BRITANNIC MAJESTY'S GOVERNMENT, and is issued for the information of such persons only as need to know its contents in the course of their official duties. Any person finding this document should hand it in to a British forces unit or to a police station for its safe return to the MINISTRY OF DEFENCE, (Sy 3(A)), METROPOLE BUILDING, NORTHUMBERLAND AVENUE, LONDON WC2N 5BL with particulars of how and where found. THE UNAUTHORIZED RETENTION OR DESTRUCTION OF THE DOCUMENT IS AN OFFENCE UNDER THE OFFICIAL SECRETS ACTS OF 1911-1989. (When released to persons outside Government service, this document is issued on a personal basis and the recipient to whom it is entrusted in confidence, within the provisions of the Official Secrets Acts 1911-1989, is personally responsible for its safe custody and for seeing that its contents are disclosed only to authorized persons).

CARRIER, PERSONNEL, FULL TRACKED Mk 2 AND 2/1 (FV 432)

TECHNICAL HANDBOOK - MODIFICATION INSTRUCTION

Note ...

These Pages 1 and 2, Issue 2, supersede Pages 1 and 2, Issue 1 dated May 91. To correct the heading.

SUBJECT: 8 metre mast mountings  
(MAE No 20/6/0001)

INTRODUCTION

1 This instruction introduces and details the manufacture and fitting of six steel mounting pads to the hull. This allows the 8 metre mast to be stowed on the hull and erected on or off the FV 432.

1.1 Limitations on use of equipment. Nil

APPLICABILITY

2 All vehicles (Code No 0040-0111, 0040-0112, 0040-2111, 0040-2112, 0040-3002, 0042-3000, 0042-3001, 0045-3000) held by user units.

2.1 Unmodified stock held in RAOC and Technical Stores.

REASON FOR MODIFICATION

3 Code 2 - to improve operational performance.

PRIORITY

4 Routine

ESTIMATED TIME REQUIRED

5 Embodiment - 4 man hours

71711(92)  
Vehs & Wpns Br

RA30-031704.1  
Issue 2, Jun 92 (23X)



MODIFICATION IMPLEMENTATION PLAN

6

6.1 This modification is to be implemented by units authorised to carry out unit, field and base repairs.

6.2 Associated modification instructions: Nil

6.3 Modification plate strike action: N/A

Action required by:

7

7.1 Units and establishments holding equipment

7.1.1 Examine equipment documents to see if modification is applicable.

7.1.2 Examine equipment to see if modification is embodied.

7.1.3 Record subject, EMER number and modification code in equipment documents.

7.2 Unit authorised to carry out unit, field and base repairs

7.2.1 When requested by users or during overhaul, carry out this instruction.

7.2.2 Record completion details of modification against appropriate entry in equipment documents.

7.2.4 Complete AF G1084A when reporting completion of the modification Data Centre using the following FORWARD modification codes:

EQUIPMENT CODE: See Para 2  
MODIFICATION CODE: NN0000

7.3 All recipients of this instruction. Add particulars to EMER Tkd Veh E 107/2 Mod Instr Index.

Stores, tools and equipment

8

8.1 Stores or suitable equivalent to be obtained locally

<u>Item No</u>	<u>COSA Section</u>	<u>NSN/Part No</u>	<u>Designation</u>	<u>Qty per veh</u>
1	G2	9510-99-964-6962	Steel, bar, carbon hot rolled 40 mm x 12	A/R
2	G2	9510-99-964-7003	Steel bar carbon hot rolled 80 mm x 40	A/R

Sequence of operations

Note ...

Item numbers quoted refer to those used in list of stores at Para 8.

9 Carry out modification as follows:

9.1 Manufacture four pads from item (1) to the dimensions shown on drawing (Fig 1).

9.2 Manufacture two pads from item (2) to the dimensions shown on drawing (Fig 2).

9.3 Mark out the positions on the vehicle hull in accordance with Fig 3 where each of the pads will be located.

9.4 Prepare hull surface and weld pads in position.

9.5 Clean welds and paint exposed surfaces.

Testing after embodiment

10 Nil

EFFECT ON WEIGHT

11 Negligible

PUBLICATION AMENDMENTS

12 Necessary amendments will be issued separately.

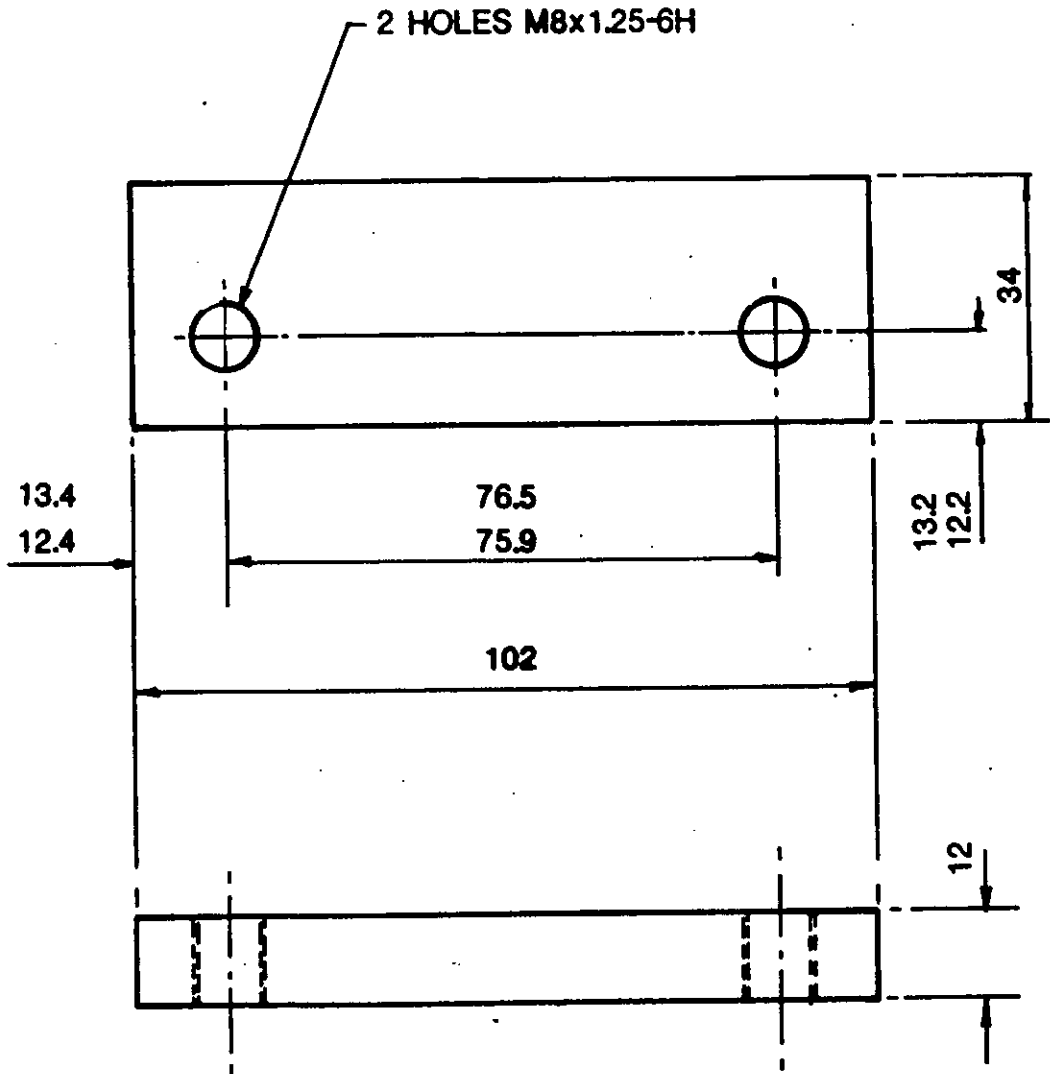

Fig 1 Pad

V10011/1

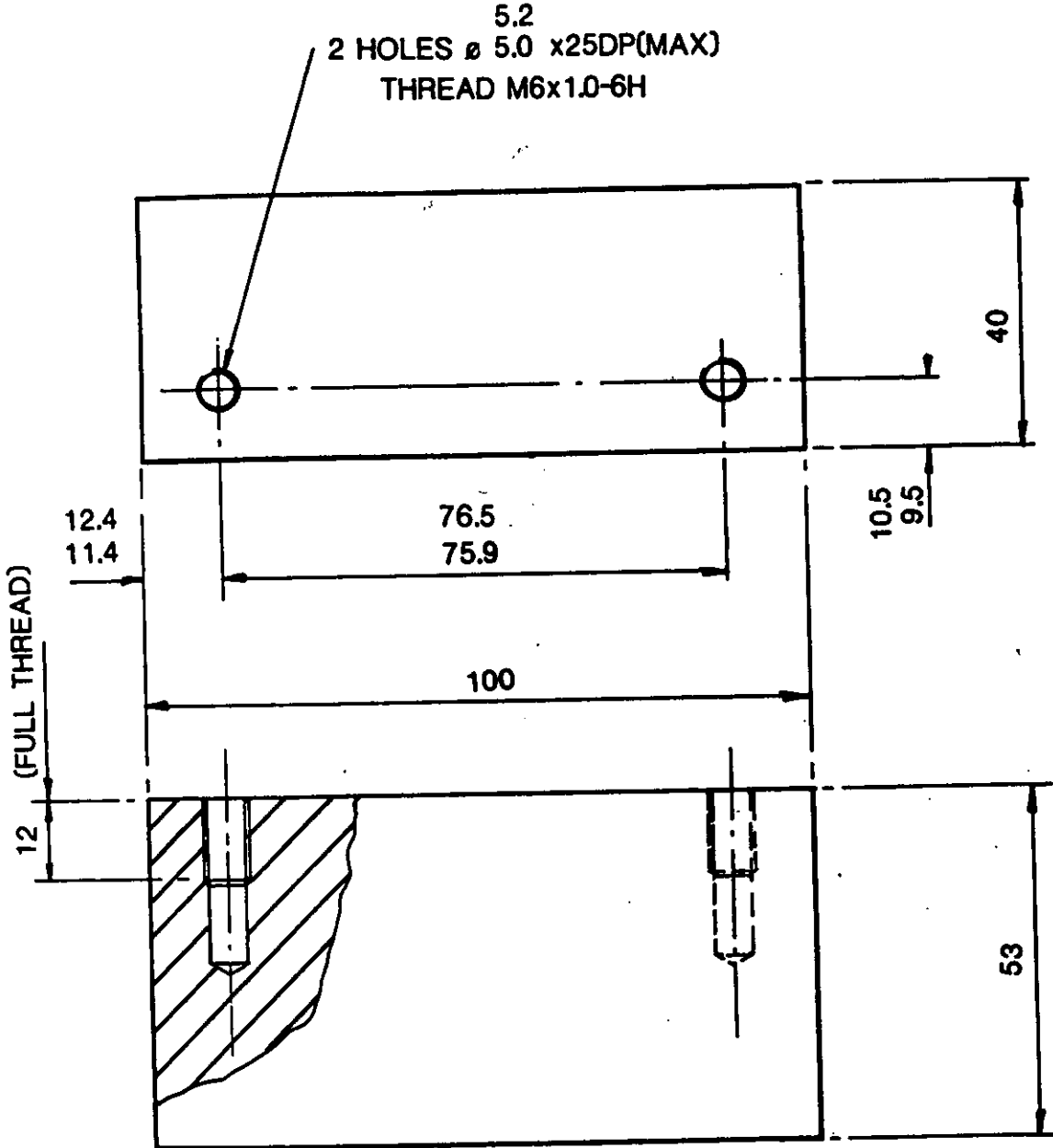

Fig 2 Pad

V10011/2

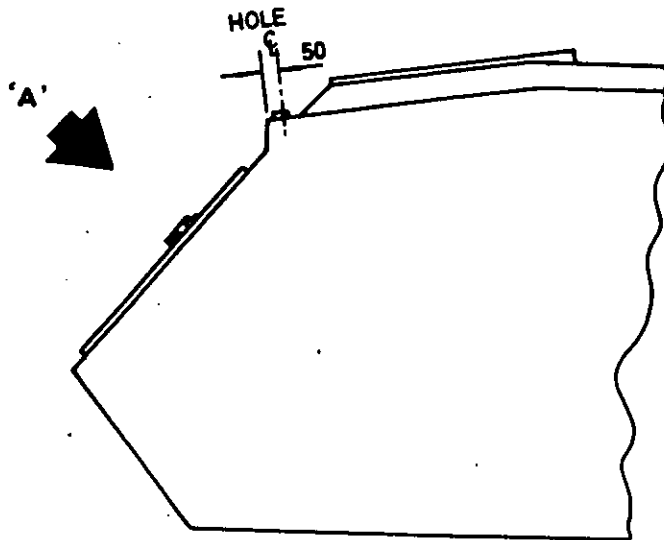
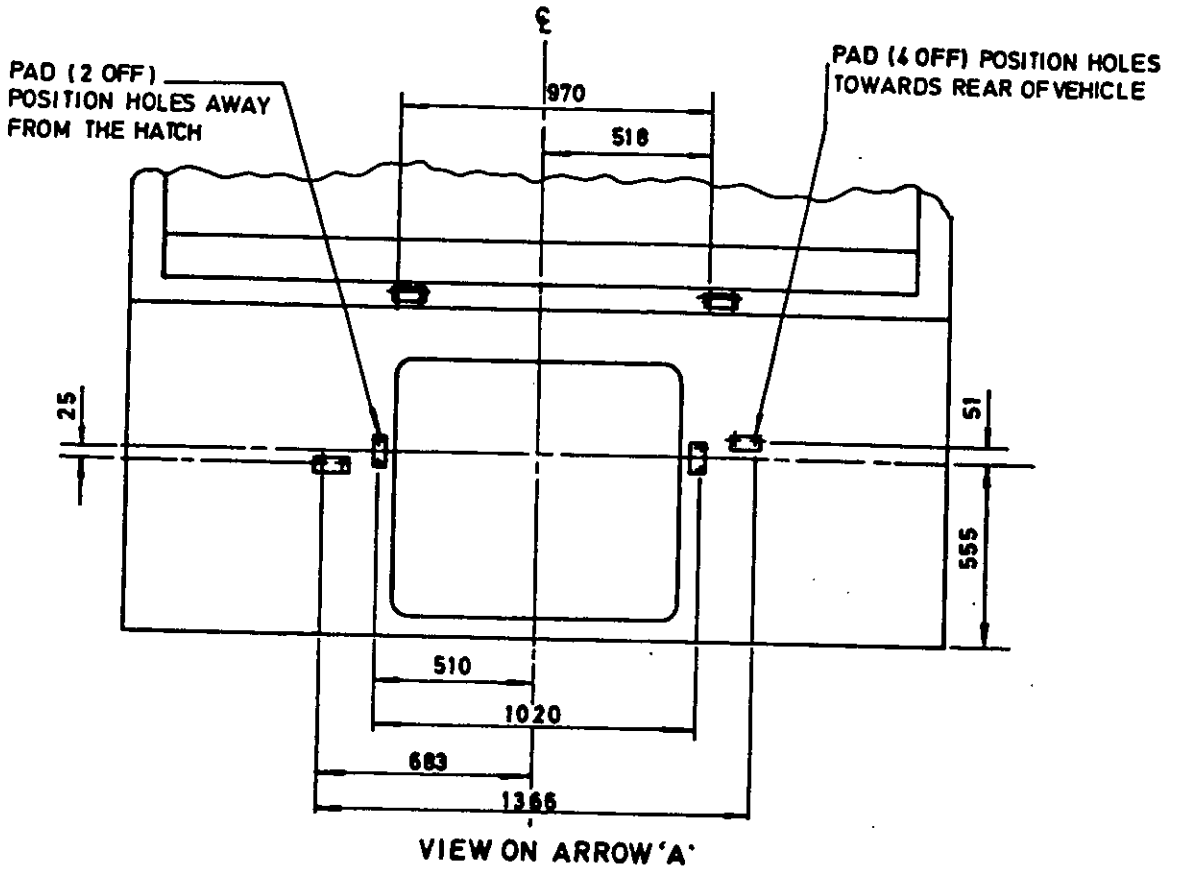

Fig 3 Vehicle modification

V10037/1

71612(58)  
Vehs & Wpns Br

RA30-031704.6  
Issue 1, May 91

CONDITIONS OF RELEASE

1. This information is released by the UK Government to the recipient Government for Defence purposes only.
2. This information must be accorded the same degree of security protection as that accorded thereto by the UK Government.
3. This information may be disclosed only within the Defence Department of the recipient Government, except as otherwise authorised by Ministry of Defence (Army).
4. This information may be subject to privately owned rights.

THIS DOCUMENT IS THE PROPERTY OF HER BRITANNIC MAJESTY'S GOVERNMENT, and is issued for the information of such persons only as need to know its contents in the course of their official duties. Any person finding this document should hand it into a British forces unit or to a police station for its safe return to the MINISTRY OF DEFENCE D/MOD Sy LONDON SW1A 2HB with particulars of how and where found. THE UNAUTHORISED RETENTION OR DESTRUCTION OF THE DOCUMENT IS AN OFFENCE UNDER THE OFFICIAL SECRETS ACTS OF 1911-1989. (When released to persons outside Government service, this document is issued on a personal basis and the recipient to whom it is entrusted in confidence within the provision of the Official Secrets Acts 1911-1989, is personally responsible for its safe custody and for seeing that its contents are disclosed only to authorised persons).

**CARRIER, PERSONNEL, FULL TRACKED  
MK 1, 1/1, 2 AND 2/1 (FV 432)**

**TECHNICAL HANDBOOK – MODIFICATION INSTRUCTION**

**SUBJECT: 2 Kg dry powder fire extinguisher  
(MAE 43/0/0013)**

**INTRODUCTION**

1 This instruction details additional external fittings for the 'Amerex' fire extinguisher which replaces the BCF type.

1.1 Limitations on use of equipment: Nil.

**APPLICABILITY**

2

2.1 Front plate – upper and rear door of 432 Mk 1, 1/1, Mk 2 and 2/1 vehicles (Code No 0040-0111, 0040-0012, 0040-2111, 0040-2112, 0040-3000, 0041-3001, 0041-3002, 0041-3003, 0042-3000, 0042-3001, 0045-3000, 0060-3000).

2.2 Unmodified stock, held at all levels of technical storage.

**REASON FOR MODIFICATION**

3 Code 1 – to improve safety.

**PRIORITY**

4 Immediate.

**ESTIMATED TIME REQUIRED**

5 Embodiment: 1 1/2 man hours.

## MODIFICATION IMPLEMENTATION PLAN

6

6.1 This modification is to be implemented by units authorised to carry out Unit, Field or Base repairs.

6.2 Associated modification instructions: Nil.

6.3 Modification plate strike action: N/A

### Action required by:

7

#### 7.1 Units and establishments holding equipment.

7.1.1 Examine equipment to see if modification is embodied and where necessary demand the stores required.

7.1.2 On receipt of stores, request REME to modify equipment.

7.1.3 Record the modification Subject and EMER number in equipment documents.

#### 7.2 Units authorized to carry out Unit, Field or Base repairs.

7.2.1 When requested by users or during overhaul, obtain the modification sets and local stores items listed in Para 8 and carry out this Modification Instruction.

7.2.2 Record completion details of modification against appropriate entry in equipment documents.

7.3 All recipients of this instruction. Add particulars to EMER Tracked Vehicles E 107/2 Mod Instr Index.

### Stores, tools and equipment

8

#### 8.1 Stores to be demanded

8.1.1 The following modification set is to be demanded quoting this instruction as authority for demand, and

8.1.2 Registration number of vehicle for equipment held in user units.

8.1.3 Registration number of vehicle for unmodified stock held at all levels of technical storage.

## NOTE

These Pages 3 to 6 Issue 2 supersede Pages 3 to 6, Issue 1 dated Jan 94. Test and figures have been amended.

Item No	DMC	NSN/Part No	Designation	Qty per eqpt
	9ACR	2540-99-876-0078 (FV 952588)	Mod set: External fire extinguisher replacement scheme, comprising:	1
1	9ACR	4210-99-441-4701 (FV 952591)	Mounting plate rear door	1
2	9ACR	4210-99-736-3532 (FV 952586)	Mounting plate front glacis L/H	1
3	G1	530 <sup>5</sup> <del>3</del> -99-122-5360	Screw hex hd M6 x 16 mm lg	11
4	G1	5305-99-941-9918	Screw C/sk hd 2BA x 3/8 in. lg	6
5	G1	5305-99-122-5361	Screw hex hd M6 x 20 mm lg	6
6	G1	5306-99-122-2792	Bolt hex hd M12 x 70 mm lg	2
7	G1	5310-99-101-3428	Washer shakeproof c/sk	6
8	G1	5310-99-137-9232	Washer s/coil lock M6	18
9	G1	5310-99-138-9229	Washer s/coil lock M12	2
10	G1	5310-99-122-5295	Nut plain hex M6	17
11	G1	5310-99-122-5298	Nut plain hex M12	2
8.2 <u>Stores to be manufactured</u>				
12		FV 2200586	Spacer	2
8.3 <u>Stores to be removed and discarded</u>				
13	G1	5306-99-941-0343	Bolt hex hd UNF 1/2 in. x 2 in. lg	2
14	G1	5310-99-941-0917	Nut plain hex UNF 1/2 in.	2
15	G1	5310-99-941-6658	Washer lock s/coil lock 1/2 in.	2



**Sequence of operations**

**NOTE**

The item numbers of Para 8 are used as references throughout this instruction.

**9 Carry out the modification as follows:**

Refer to Fig 1 and 2 to fit brackets (items 1 to 12 inclusive) as detailed.

9.1 Remove existing extinguishers and brackets from rear door (2 off) and front plate upper (1 off). Return extinguishers to stores to be used for replacement of internal hand extinguishers.

9.2 Attach fire extinguisher bracket (6MT1/4210-99-839-9904) to mounting plate (item 2) using screws, washers and nuts (items 5, 8 and 10).

**NOTE**

See Fig 1 for manufacture details of spacer (item 12).

9.3 Remove bolts, nuts and washers (items 13, 14 and 15) from smoke discharger (Fig 1) and attach mounting plate and spacers (items 2 and 12) to smoke discharger bracket using bolts, washers and nuts (items 6, 9 and 11).

9.4 Attach fire extinguisher brackets (6MT1/4210-99-839-9904) to mounting plate (item 1), see Fig 2, using screws, washers and nuts (items 3, 8 and 10) and weld on nuts.

9.5 After welding on nuts remove fire extinguisher brackets from mounting plate (item 1).

9.6 Repair paint finish to DTD 5555 and Def Stan 03-32.

9.7 Attach mounting plate (item 1) to existing tapped pads in rear door using screws and washers (items 4 and 7).

9.8 Attach fire extinguisher brackets (6MT1/4210-99-839-9904) to mounting plate (item 1) using (items 3, 8 and 10).

9.9 Clip on 'Amerex' extinguishers qty 3 (6MT1/4210-99-839-9905).

**Testing after embodiment**

10 Nil

**EFFECT ON WEIGHT**

11 Negligible

**PUBLICATION AMENDMENTS**

**NOTE**

Necessary amendments will be issued separately.

12 User Handbooks 14168  
14693

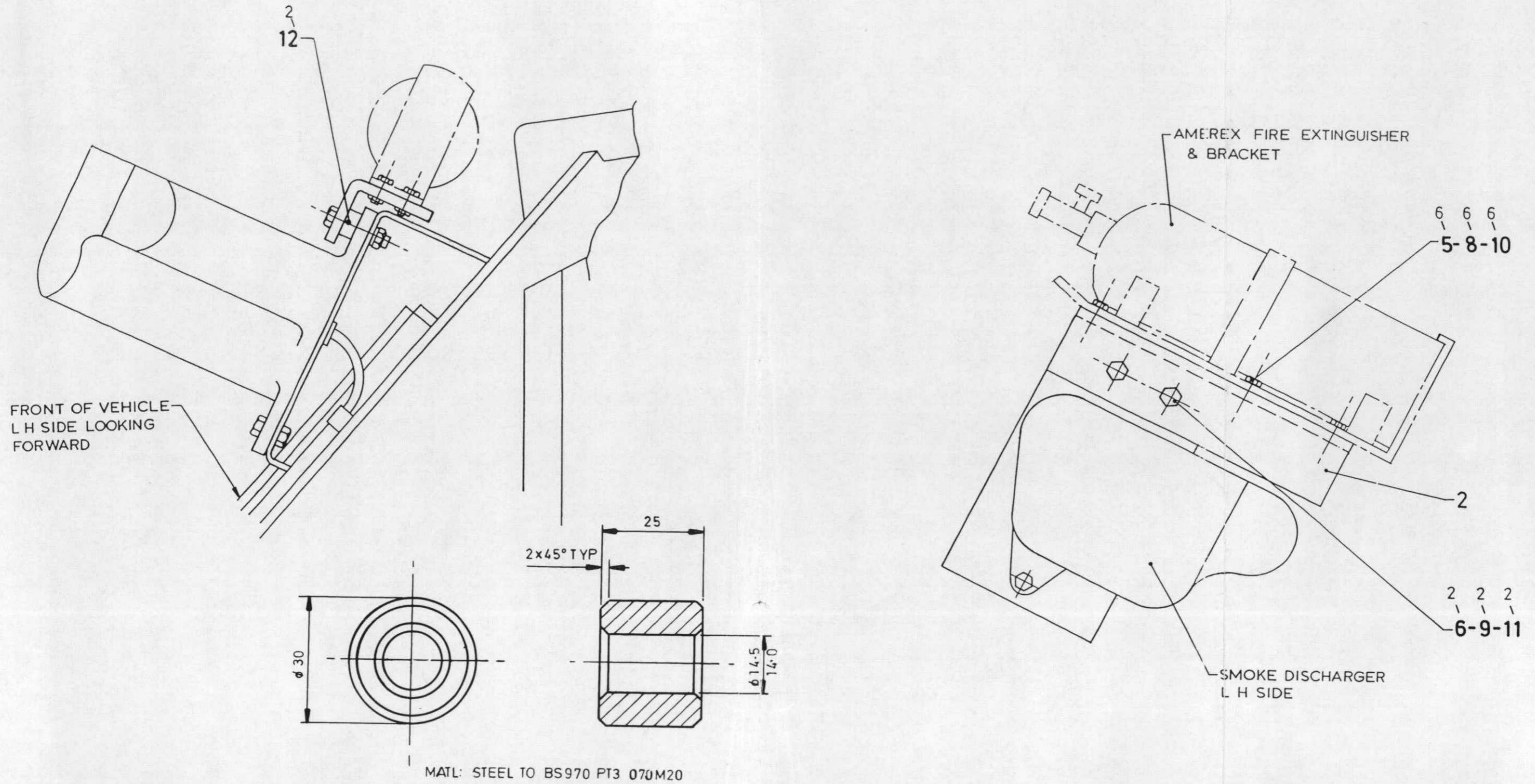

Fig 1 Fire extinguisher mounting front

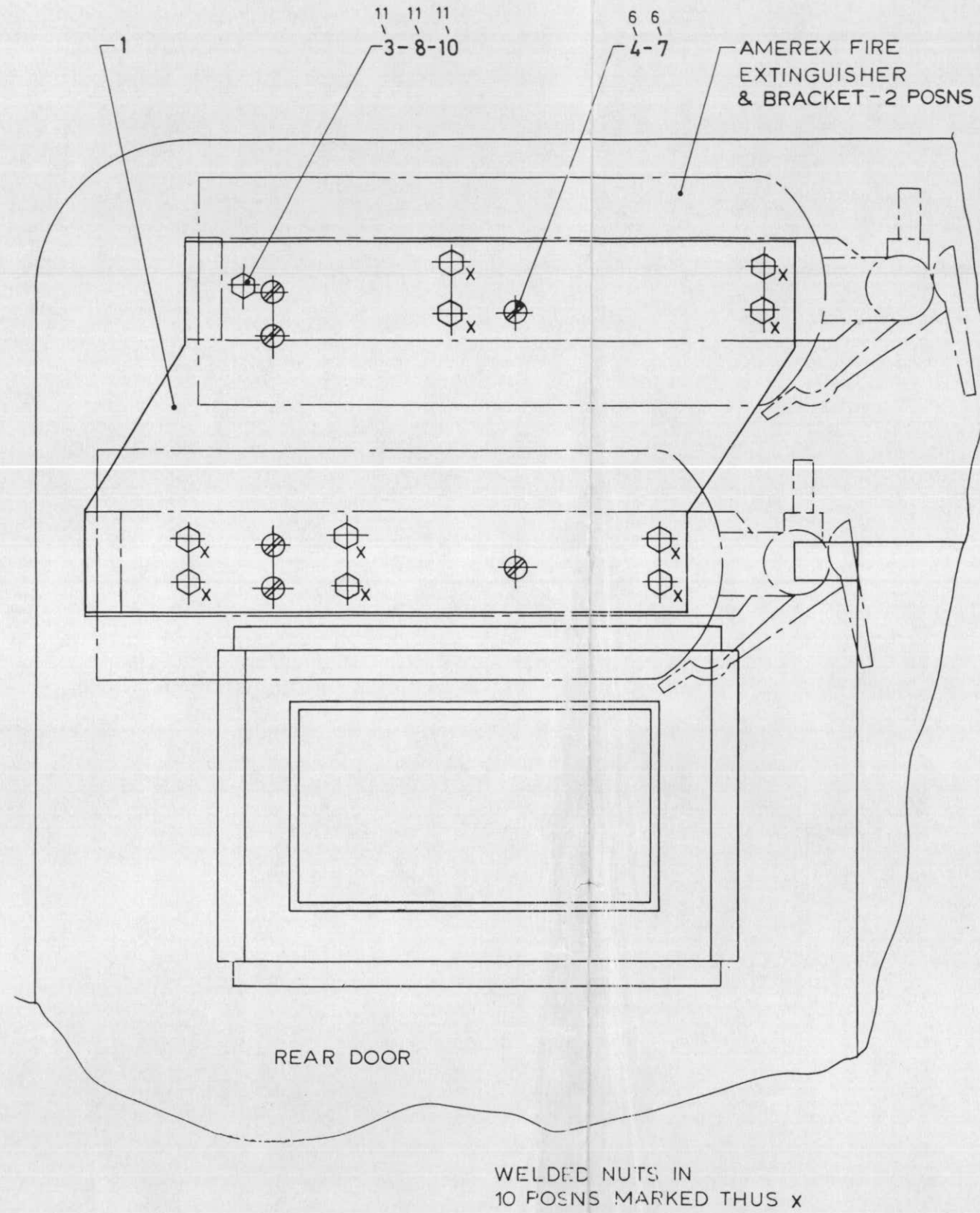

Fig 2 Fire extinguisher rear door

V10924/4

CONDITIONS OF RELEASE

1. This information is released by the UK Government to the recipient Government for Defence purposes only.
2. This information must be accorded the same degree of security protection as that accorded thereto by the UK Government.
3. This information may be disclosed only within the Defence Department of the recipient Government, except as otherwise authorised by Ministry of Defence (Army).
4. This information may be subject to privately owned rights.

THIS DOCUMENT IS THE PROPERTY OF HER BRITANNIC MAJESTY'S GOVERNMENT, and is issued for the information of such persons only as need to know its contents in the course of their official duties. Any person finding this document should hand it into a British forces unit or to a police station for its safe return to the MINISTRY OF DEFENCE D.MOD Sy LONDON SW1A 2HB with particulars of how and where found. THE UNAUTHORISED RETENTION OR DESTRUCTION OF THE DOCUMENT IS AN OFFENCE UNDER THE OFFICIAL SECRETS ACTS OF 1911-1989. (When released to persons outside Government service, this document is issued on a personal basis and the recipient to whom it is entrusted in confidence within the provision of the Official Secrets Acts 1911-1989, is personally responsible for its safe custody and for seeing that its contents are disclosed only to authorised persons).

**CARRIER, PERSONNEL, FULL TRACKED, MKs 2 and 2/1 (FV432)**

**TECHNICAL HANDBOOK - MODIFICATION INSTRUCTION**

**SUBJECT: Crew Air Heater**

(Approval No UOR(L) 15/94)

*AUTHORISED TO FIT IN FV436  
TELECON TURNER/WALTON 7/9/98*

**INTRODUCTION**

1 This Modification Instruction introduces and details the installation of a re-circulating air heater, which operates independently from the engine, using a diesel fuel supply from the vehicle main tank.

1.1 Limitations on use of equipment. Nil.

**APPLICABILITY**

2 Carrier, Personnel, Full Tracked, MKs 2 and 2/1 (FV432).

2.1 Fitted to subject vehicles on deployment to FRY. Vehicles to be modified will be advised by ES Branches.

**REASON FOR MODIFICATION**

3 Code 2 - to improve operational performance.

**PRIORITY**

4 Immediate.

**ESTIMATED TIME REQUIRED**

5 Embodiment - 3.5 man hours

**MODIFICATION IMPLEMENTATION PLAN**

6

6.1 This modification is to be implemented by units authorized to carry out Unit, Field and Base repairs or by specially assigned installation teams.

6.2 Associated modification instruction: Nil.

6.3 Modification plate strike action: Nil

Action required by:

7

7.1 Units and establishments holding equipment.

7.1.1 Examine equipment documents to see if modification is applicable.

7.1.2 Examine equipment to see if modification is embodied.

7.1.3 Record the Subject, EMER number and modification code in equipment documents.

7.2 Units authorized to carry out Unit, Field and Base repairs.

7.2.1 When requested by users or during overhaul, obtain the items listed in Para 8.1 and carry out this modification instruction.

7.2.2 Record completion details of modification against appropriate entry in equipment documents.

7.3 All recipients of this instruction. Add particulars to EMER Tracked Vehicles E 107/2 Mod Instr Index.

Stores, tools and equipment

8

8.1 Stores to be demanded.

The following modification items are to be demanded quoting this instruction as authority for demand and

8.1.1 Registration number of vehicle for equipment held by user units.

8.1.2 Registration number of vehicle for unmodified stock held at all levels of technical storage.

Item No	DMC	NSN/Part No	Designation	Qty per eqpt
	9ACR	2540-99-842-0395	Mod set: Installation kit vehicle heater comprising:	1
1		FV2200585	Heater, air, 5 kw	(1)
2		2540 99 795 3436 204 00 099	Carrier, fuse	(1)
3		18759	Terminal, ring	(1)
4		8989	Louvre, outlet, assy	(1)
5		10021	Hose, flexible	(1)
6		10030	Clip, duct	(2)

Item No	DMC	NSN/Part No	Designation	Qty per eqpt
7		19740	Adaptor, fuel	(1)
8		19739	Locknut 5/8 in. UNF	(1)
9		17467	Seal	(1)
10		17466	Adaptor, hose	(1)
11		17465	Hose, armoured	(1)
12		10 2063 01 20 98	Clip, worm drive	(2)
13		17471	Clip, 'P'	(3)
14		18066	Tie, nylon	(30)
15		19735	Cover, armoured	(1)
16		E1010	Exhaust, assembly	(1)
17		10204	Elbow, exhaust	(1)
18		152 61 102	Clamp, exhaust 26 mm	(2)
19		152 10 051	Clip, exhaust 28 mm	(1)
20		17469	Sealant	(1)
21		17468	Plate, warning, exhaust	(1)
22		17124	Plate, warning, battery	(1)
23		19728	Nut, hex, 5/8 in. UNF	(4)
24		19736	Nut, hex, 5/16 in. UNF	(5)
25		19729	Washer, flat, 5/8 in.	(20)
26		19737	Washer, flat, 5/16 in.	(4)
27		19730	Washer, spring, 5/8 in.	(4)
28		19738	Washer, spring, 5/16 in.	(5)

8.2 Stores to be obtained locally.

29 Nil

8.3 Stores to be modified.

30 Nil

8.4 Stores to be removed and retained in modification packaging.

Item No	DMC	NSN/Part No	Designation	Qty per eqpt
31		FV651058	Cover, blanking	2
32	G1	5310-99-941-4171	Nut, 3/4 in. UNF	2
33	G1	5310-99-941-4168	Nut, locking 5/16 in. UNF	8
34		FV651070	Washer, 3/4 in. disc	2
35	9ACR	2910-99-867-4702	Screw, spill valve	1
36	G1	5310-99-941-0908	Nut, 5/8 in. UNF	1

**Sequence of operations**

**NOTES**

- (1) Item numbers of Para 8 are used as reference throughout this instruction.
- (2) The modification kits will be delivered in packaging designed to accept all retained stores as per Para 8.4.

**CAUTION**

**EQUIPMENT DAMAGE.** Ensure master switch and fuel tap are "OFF" prior to implementing this modification.

**9 Carry out modification as follows:**

9.1 Remove qty 2, 135 mm dia cover, blanking (item 31), located on the r.h. exterior of hull, each retained by qty 4, nut 5/16 in. UNF (item 33) and internally to the hull by nut 3/4 in. UNF (item 32), washer 3/4 in. (item 34). The covers and fastenings should be retained for future use in mod set packaging.

9.2 Remove debris from hull apertures and apply sealant (item 20) inside 62 mm holes.

9.3 The heater (item 1) is attached to the inside of the hull, forward of the main fuel tank, in the crew stowage area, on the upper 4, 5/8 in. UNF studs of a group of six. Ensure fastenings are a free fit prior to final assembly.

**NOTE**

It is not necessary to remove the distribution box, amplifier AF loudspeaker or any hull insulation.

9.4 If heater (item 1) mounting brackets foul hull stowage cleats, trim brackets to suit. Ensure heater air inlet pipe is located 8 mm minimum into hull wall, but does not protrude beyond hull outer face.

9.5 Apply sealant (item 20) around heater inlet/exhaust and attach heater (item 1) to vehicle using qty 4, nut 5/8 in. UNF (item 23), qty 20 washer, flat 5/8 in. (item 25) and qty 4, washer, spring 5/8 in. (item 27). The flat washers are positioned qty 3 (A/R), between the heater and hull and qty 2, between the heater and nut on each stud. Tighten to 100 Nm (75 lbf ft) after final electrical assembly.

- 9.6 Attach heater negative lead directly to the nearest heater mounting stud.
- 9.7 Remove fuse carrier (item 2) and route positive lead forward along sponson wall (under existing cable clips), follow signal battery conduit down hull wall, across sponson to rear of auto batteries. Route behind main positive lead to signal batteries. Re-connect fuse carrier and attach to positive connection using terminal (item 3). Fasten in position as necessary using tie (item 14).

NOTE

If replacement of the fuse, 16A (NSN Z32/5920-12-159-2175) from the carrier is required, grasp carrier, push ends together and rotate gently through 45 degrees to release.

- 9.8 Attach louvre, outlet (item 4) to the upper cable retaining fastenings on the side of the main fuel tank frame next to the heater. Tighten to 5.3 Nm (4.1 lbf ft).
- 9.9 Connect hose, flexible (item 5) to heater (item 1) and louvre, outlet (item 4) using qty 2 clip (item 6). Trim to length as necessary.
- 9.10 The louvre outlet is adjustable and can be rotated to provide optimum airflow direction.
- 9.11 Remove rear floor panel and inner r.h. rear corner cover from vehicle to provide access to fuel collector tank and route for heater armoured fuel hose (refer to Fig 1).
- 9.12 Remove screw, spill valve (item 35) and nut (item 36) from the collector tank and retain for future use in mod set packaging.
- 9.13 Assemble the adaptor, fuel (item 7), locknut (item 8), seal (item 9) and adaptor, hose (item 10) to the collector tank. Ensure fuel supply is free from contamination. Tighten to 11.2 Nm (8.3 lbf ft).
- 9.14 Attach hose, armoured (item 11) to the adaptor (item 10) using clip (item 12).
- 9.15 Attach hose, armoured (item 11) to the existing pipework as shown Fig 1. Attach the hose, armoured to the hull using qty 3 clip 'P' (item 13) and finally route through the lifting eye on the side of the fuel tank support frame or attach to stowage cleats using tie (item 14).
- 9.16 Trim hose, armoured (item 11) to length as necessary.
- 9.17 Prior to connecting the armoured fuel hose to the heater, a suitable container should be placed under the end of the armoured fuel hose and the fuel tap turned on to bleed all air from the fuel supply circuit.
- 9.18 Connect hose, armoured (item 11) to heater elbow using clip (item 12).
- 9.19 Do not replace rear floor panel at this stage.
- 9.20 To exterior of vehicle, attach exhaust, assy (item 16) to heater-exhaust outlet using elbow (item 17) and qty 2 clamp (item 18).
- 9.21 Retain pipe, exhaust in position (45 degrees forward) using clip, exhaust (item 19 - drill out to suit 5/16 in. stud), nut 5/16 in. UNF (item 24) and washer, spring, 5/16 in. (item 26) fastened to 5/16 in. UNF stud forward of armoured housing. Tighten to 11.2 Nm (8.3 lbf ft).
- 9.22 Check sealant around heater inlet/exhaust and exterior of hull and if necessary apply additional sealant (item 20). **Under no circumstances should any heater exhaust gas be allowed to enter the vehicle through this route.**



9.23 Attach cover, armoured (item 15) to the hull using the existing 5/16 in. UNF studs and qty 4 nut 5/16 in. UNF (item 24), qty 4 washer, flat 5/16 in. (item 26) and qty 4 washer, spring 5/16 in. (item 28). Tighten to 11.2 Nm (8.3 lbf ft).

9.24 Switch on fuel supply, master switch and turn heater control switch fully clockwise (No 4 setting). There will be a delay of 1 1/2 to 4 minutes before the heater will start (this will also occur if the heater is switched 'OFF' then 'ON' again). When the heater is operating, check armoured fuel hose for leaks at connections.

9.25 If after approximately 5 minutes, heater fails to start, switch to 'Off' setting, then turn switch back to 'No 4' setting. Heater should then start.

9.26 Replace rear floor panel and inner r.h. rear corner cover.

9.27 Attach warning plate (item 21) to hull above heater exhaust outlet pipe and warning plate (item 22) to heater.

9.28 Repair paint, finish to DTD 5555A and Def Stan 03-32.

#### NOTE

When heater is switched off, the blower motor will continue to run for a short period of time to purge the heater. It is important to note that whilst the heater is in use or during the purge cycle, the signals batteries are not disconnected.

#### Testing after embodiment

10 Nil.

#### Effect on weight

11 The incorporation of this modification will result in a overall increase in weight of 15 kg.

#### PUBLICATION AMENDMENTS

12 Necessary amendment(s) will be issued separately.

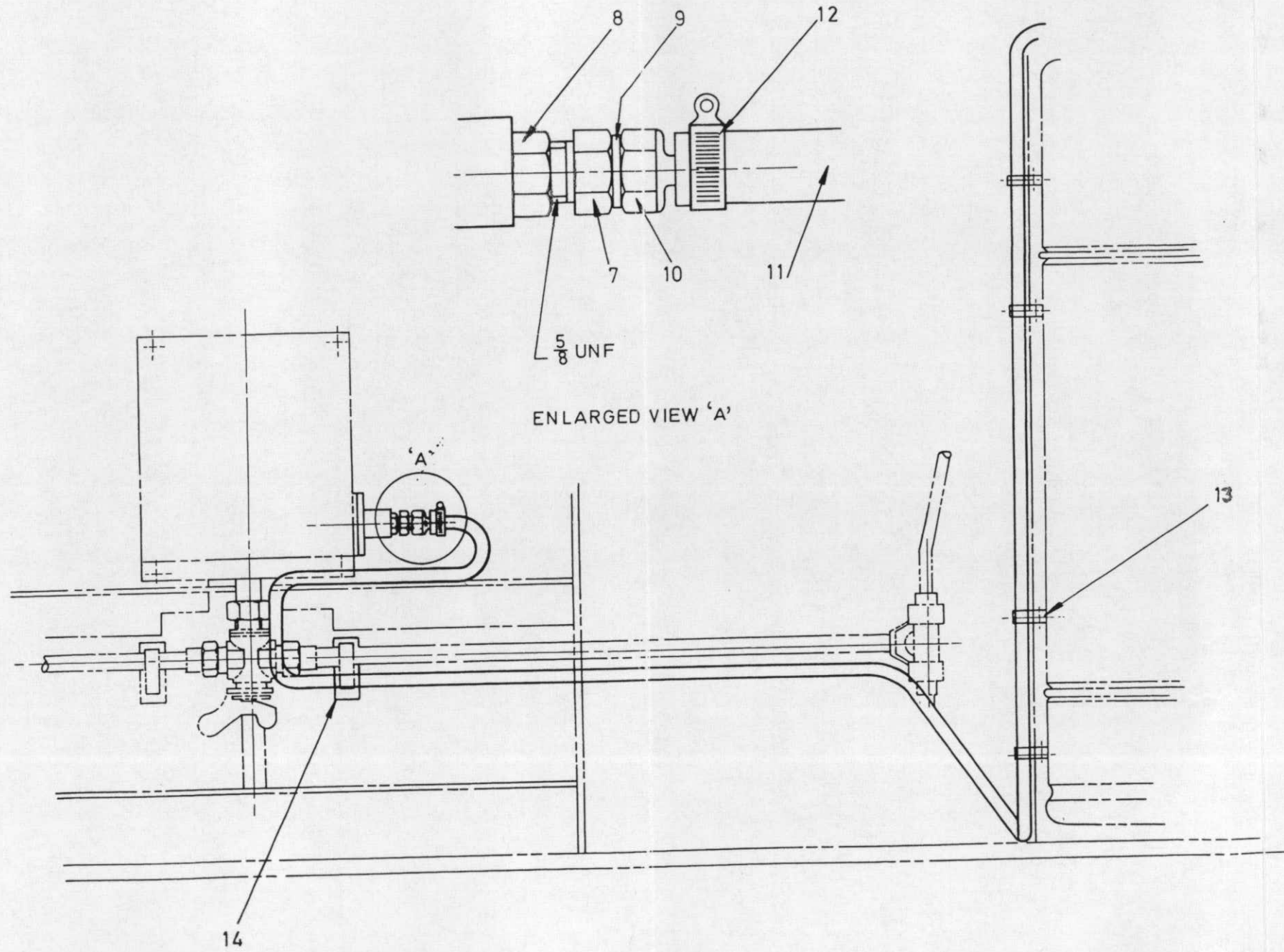

Fig 1 Crew heater fuel pipe

V12427/1

CONDITIONS OF RELEASE

- |  |  |
|--|--|
| 1. This information is released by the UK Government to the recipient Government for Defence purposes only.                | 3. This information may be disclosed only within the Defence Department of the recipient Government, except as otherwise authorized by Ministry of Defence (Army). |
| 2. This information must be accorded the same degree of security protection as that accorded thereto by the UK Government. | 4. This information may be subject to privately owned rights.  |

THIS DOCUMENT IS THE PROPERTY OF HER BRITANNIC MAJESTY'S GOVERNMENT, and is issued for the information of such persons only as needed to know its contents in the course of their official duties. Any person finding this document should hand it into a British forces unit or to a police station for its safe return to the MINISTRY OF DEFENCE D.MOD Sy LONDON SW1A 2HB with particulars how and where found. THE UNAUTHORIZED RETENTION OR DESTRUCTION OF THIS DOCUMENT IS AN OFFENCE UNDER THE OFFICIAL SECRETS ACTS OF 1911-1989. (When released to persons outside government service, this document is issued on a personal basis and the recipient to whom it is entrusted in confidence within the provision of the Official Secrets Acts 1911-1989, is personally responsible for its safe custody and for seeing that its contents are disclosed only to authorized persons).

**CARRIER PERSONNEL, FULL TRACKED, Mks 2 and 2/1 (FV 432)**

**TECHNICAL HANDBOOK - MODIFICATION INSTRUCTION**

**SUBJECT: Mini-pipe fascine lighting**

**(Approval No 43/2/0004 )**

**INTRODUCTION**

1 This instruction introduces and details the installation of a power supply for the mini-pipe fascine marker lights required to comply with current lighting regulations.

1.1 Limitations on use of equipment. Nil.

**APPLICABILITY**

2 Carrier, Personnel, Full Tracked, Mks 2, 2/1 and 2/2 (Fv 432). (Code No 0040-0111, 0040-0012, 0040-2111, 0040-2112, 0040-3000, 0042-3000, 0042-3001, 0045-3000, 0060-3000).

**REASON FOR MODIFICATION**

3 Code 2 - to improve operational performance

**PRIORITY**

4 Routine

**ESTIMATED TIME REQUIRED**

5 Embodiment: 1.5 man-hours.

**MODIFICATION IMPLEMENTATION PLAN**

6

- 6.1 This modification is to be implemented by units authorized to carry out Unit, Field and Base repairs or by specially assigned installation teams.
- 6.2 Associated modification instructions. Nil.
- 6.3 Modification plate strike action: NA.

**Action required by:**

7

7.1 Units and establishments holding equipment.

- 7.1.1 Examine documents to see if modification is applicable.
- 7.1.2 Examine equipment or modification record plate to see if modification is embodied.
- 7.1.3 Record the subject, EMER number and modification code in equipment documents.

7.2 Army units authorized to carry out Unit, Field and Base repairs.

- 7.2.1 When requested by users or during overhaul, obtain the items listed in Para 8 and carry out this modification.
- 7.2.2 Record completion details of modification against appropriate entry in vehicle documents.

7.3 All recipients of this instruction. Add particulars to EMER Tracked Vehicles E 107/2 Mod Instr Index.

**Stores, tools and equipment**

8

8.1 Stores to be demanded.

- 8.1.1 The following items are to be demanded quoting this instruction as authority for demand, and
- 8.1.2 Registration/Serial number of vehicle for equipment held by user units.
- 8.1.3 Registration number of vehicle for unmodified stock held at all levels of technical storage.

Item No	DMC	NSN/Part No	Designation	Qty per eqpt
	9ACR	6220-99-192-4018 (FV 951933)	Mod set comprising:	1
1	9AHY	<del>ABB 03E10SL 3SSN</del> 2920-99-500-5721	Connector, Sq flange	(2)
2	Z32	5935-99-785-9113	Receptacle protective cap ABB 0BE 10SL X PCA	(2)

Item No	DMC	NSN/Part No	Designation	Qty per eqpt
3	Z32	<del>5935-99-500-2103</del> ABB-165 KFP	PLUG END SEAL <u>Grommet filter plug</u>	(2)
4	Y3	6145-99-901-2998 (FV 2094700-03)	Single core standard cable type NYVIN 16	(4)
5	Z42	5975-99-901-1361 ?	Sleeve polyc yellow 2.0 i.d. Helsyn TH20 Def Stan 59-15	(4)
6	Z1	9905-99-804-4136 (FV(S) 7/2/1)	Ident label	(2)
7	6MT4	5340-99-205-6507 (FV(S) 7/3/1)	Clip ident label	(2)
8	G1	5305-99-122-5273	Screw. machine, flat, c/sk, slotted hd M3 x 12	(8)
9	G1	5305-99-135-0424	Screw, machine, pan hd, M4 x 16	(2)
10	G1	5310-99-135-0754	Nut, plain, hex M3	(8)
11	G1	5310-99-135-0755	Nut, plain hex M4	(2)
12	G1	5310-99-138-9224	Washer, lock M3	(8)
13	G1	5310-99-138-9225	Washer, lock M4	(2)
14	G1	<del>5310-99-759-2084</del> 396-0691	Washer, flat M4	(2)
15	6MT4	5340-99-801-4092 (FV(S) 6/66/1)	Sealing cone Lucas No 806445	(2)

8.2 Stores to be discarded.

16	6 MT4	5340-99-881-2217	Sealing cone (FV(S) 6/83/1)	2
----	-------	------------------	-----------------------------	---

8.3 Stores to be obtained locally.

17	<del>34B</del> Y3	9150-99-220-3658 1937	Cable lubricant Hellarine LUB/M/284ML	As reqd
18	G2	3439-99-942-5100	Solder BS 219 Type A or K	As reqd
19	<del>5F</del> Z42	5970-99-015-1685	Pressure sensitive adhesive tape 12 wide GRP 13/18051	As reqd

8.4 Stores to be modified.

20		FV 560055	Lamp support	2
----	--	-----------	--------------	---

### Sequence of operations

#### NOTE

The item numbers of Para 8 are used as references throughout this instruction.

- 9 Carry out the modification as follows:
  - 9.1 Remove lamp support FV 560055, see Fig 2 (two positions).
  - 9.2 Disconnect and remove turn and rear light clusters.
  - 9.3 Mark out and drill holes in lamp support (item 20) to accept socket assemblies, see Fig 2.
  - 9.4 Repair paint, finish to DTD 5555 and Def Stan 03-32.
  - 9.5 Fit socket assemblies (FV 951933) to lamp supports (item 20) using (items 8, 10 and 12).
  - 9.6 Attach item 2 to lamp supports using (items 9, 11, 13 and 14), see Fig 2.
  - 9.7 Replace existing sealing cones (item 16) with item (15) (FV(S) 6/66/1, see Fig 2.
  - 9.8 Refit and rewire rear lights incorporating new cables from socket assemblies, see Fig 1.
  - 9.9 Reassemble lights and refit to vehicle.

#### Testing after embodiment

- 10 Nil.

#### EFFECT ON WEIGHT

- 11 Nil.

#### PUBLICATION AMENDMENTS

#### NOTE

Necessary amendments will be issued separately.

- 12 Nil.

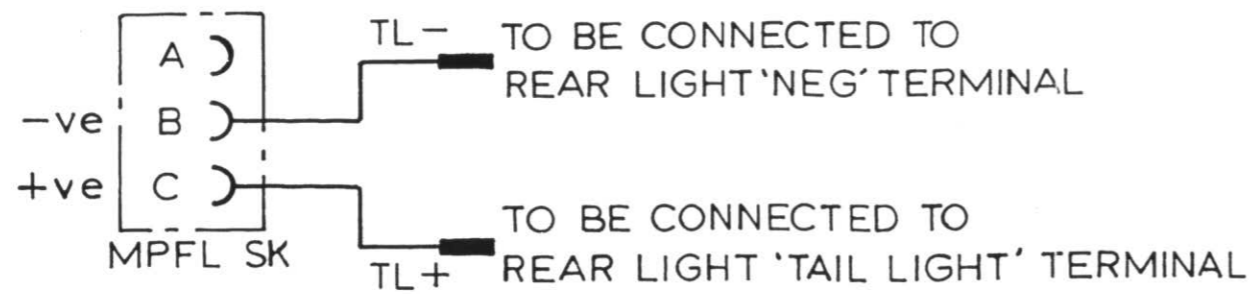
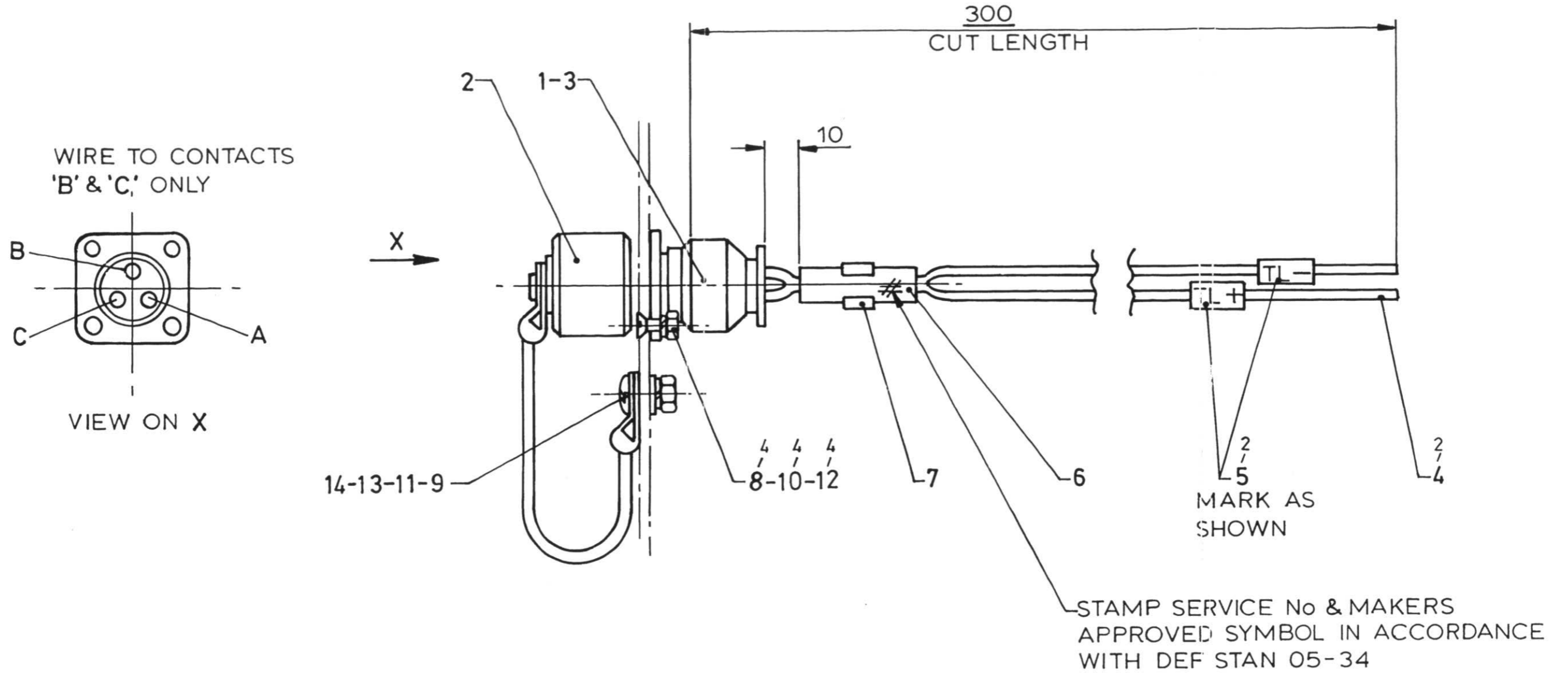

Fig 1 SK Assy - Mini-pipe fascine lighting

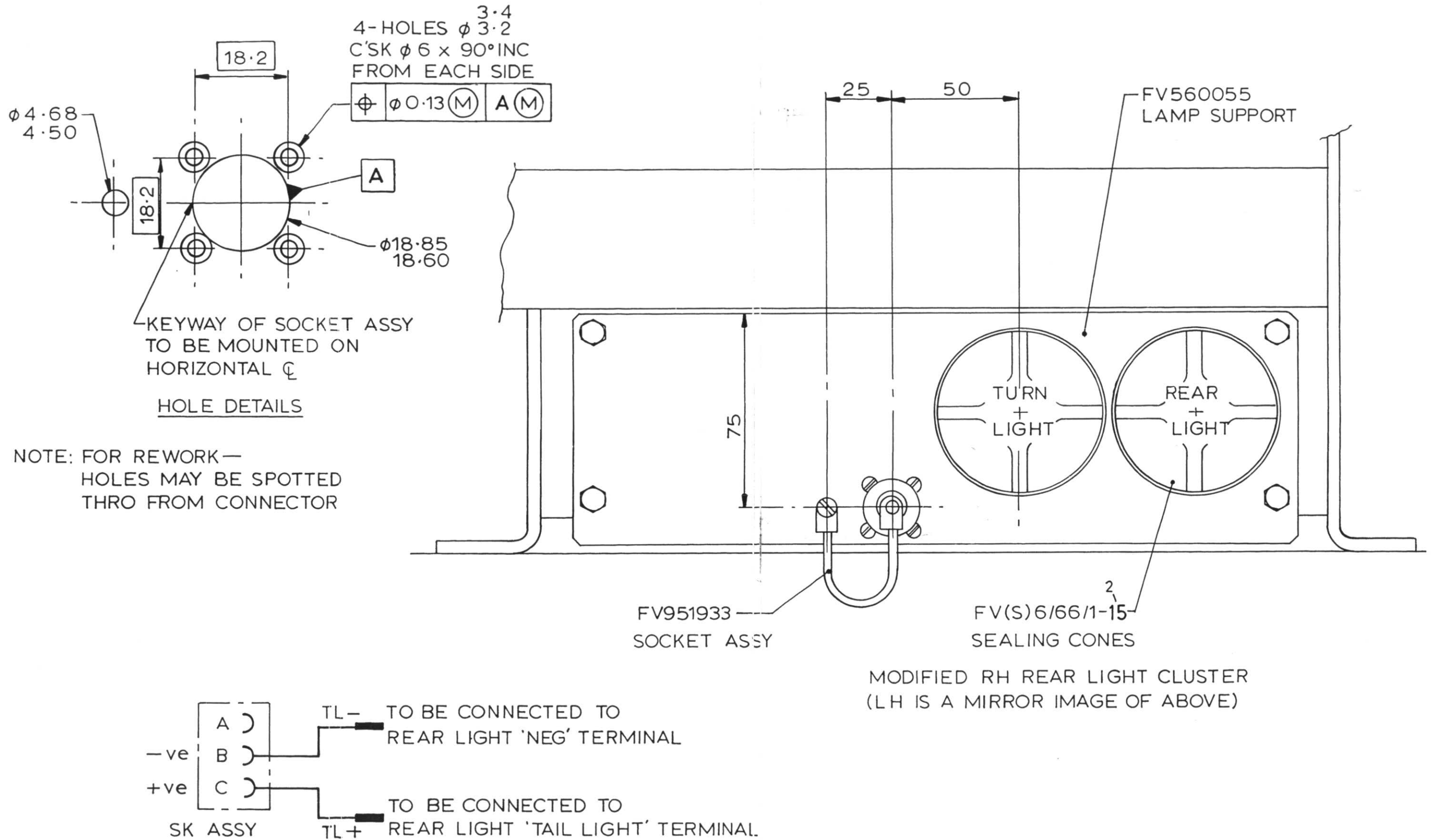

Fig 2 Mini-pipe fascine lighting



CONDITIONS OF RELEASE

- |  |  |
|--|--|
| 1. This information is released by the UK Government to the recipient Government for Defence purposes only.                | 3. This information may be disclosed only within the Defence Department of the recipient Government, except as otherwise authorized by Ministry of Defence (Army). |
| 2. This information must be accorded the same degree of security protection as that accorded thereto by the UK Government. | 4. This information may be subject to privately owned rights.  |

THIS DOCUMENT IS THE PROPERTY OF HER BRITANNIC MAJESTY'S GOVERNMENT, and is issued for the information of such persons as needed to know its contents in the course of their official duties. Any person finding this document should hand it in to a British forces unit or to a police station for its safe return to the MINISTRY OF DEFENCE D.MOD Sy LONDON SW1A 2HB with particulars how and where found. UNAUTHORIZED RETENTION OR DESTRUCTION OF THIS DOCUMENT IS AN OFFENCE UNDER THE OFFICIAL SECRETS ACTS OF 1911-1989 (When released to persons outside government service, this document is issued on a personal basis and the recipient to whom it is entrusted in confidence within the provision of the Official Secrets Acts 1911-1989, is personally responsible for its safe custody for seeing that its contents are disclosed only to authorized persons).

**CARRIER, PERSONNEL, FULL TRACKED  
MK 2 AND 2/1 (FV 432)**

**TECHNICAL HANDBOOK - MODIFICATION INSTRUCTION  
(Completely revised)**

**SUBJECT: Driver and commanders SA80 stowage.**  
(MAE 43/2/0002).

**INTRODUCTION**

- 1 This instruction details the internal fittings for the stowage of the SA80:
  - 1.1 Limitations on use of equipment. Nil.

**APPLICABILITY**

- 2
  - 2.1 Fitted to subject vehicles FV 432 Mk 2 and 2/1 (Code No. 0040-0111, 0040-0012, 0040-2111, 0040-2112, 0040-3000, 0042-3000, 0042-3001, 0045-3000, 0060-3000).
  - 2.2 Unmodified stock, held at all levels of technical storage.

**REASON FOR MODIFICATION**

- 3 Code 1 - to improve safety.

**PRIORITY**

- 4 Immediate.

**ESTIMATED TIME REQUIRED**

- 5 Embodiment: 1-1/2 man-hours.

MODIFICATION IMPLEMENTATION PLAN

6

- 6.1 This modification is to be implemented by units authorized to carry out Unit, Field or Base repairs.
- 6.2 Associated modification instructions: Nil.
- 6.3 Modification plate strike action: Nil.

Action required by

7

7.1 Units and establishments holding equipment:

- 7.1.1 Examine equipment to see if modification is embodied and where necessary demand the stores required.
- 7.1.2 On receipt of stores, request REME to modify equipment.
- 7.1.3 Record the modification Subject and EMER Number in equipment documents.

7.2 Units authorised to carry out Unit, Field or Base repairs:

- 7.2.1 When requested by users or during overhaul, obtain the modification sets and local stores items listed in Para 8 and carry out this Modification Instruction.
- 7.2.2 Record completion details of modification against appropriate entry in equipment documents.

7.3 All recipients of this instruction. Add particulars to EMER Tracked Vehicles E 107/2 Mod Instr Index.

Stores, tools and equipment

8

8.1 Stores to be demanded:

- 8.1.1 The following modification set is to be demanded quoting this instruction as authority for demand.
- 8.1.2 Registration number of vehicle for equipment held in user units.
- 8.1.3 Registration number of vehicle for unmodified stock held at all levels of technical storage.

Item No.	DMC	NSN/Part No.	Designation	Qty per eqpt
	9ACR	2540-99-839-7390 (FV 952576)	Mod Set: SA80 Rifle Stowage Comprising:	1
1	9ACR	5340-99-839-8252 (FV 952575)	Bracket mounting	(1)
2	9ACR	5340-99-839-8251 (FV 952574)	Bracket mounting	(1)
8.2 <u>Stores to be obtained locally:</u>				
3	6MT1	2540-99-740-7338 (FV 952299)	Barrel clip assy	(2)
4	6MT1	2540-99-724-5832 (FV 952327)	Butt clip	(2)
5	G1	5305-99-122-5360	Screw hex hd M6 x 16 mm lg	(4)
6	G1	5305-99-122-5366	Screw hex hd M8 x 20 mm lg	(11)
7	G1	5305-99-135-0451	Screw pan hd M8 x 20 mm lg	(1)
8	G1	5310-99-137-9232	Washer s/coil lock M6	(4)
9	G1	5310-99-138-9227	Washer s/coil lock M8	(12)
10	G1	5310-99-122-5295	Nut plain hex M6	(4)
11	G1	5310-99-122-5296	Nut plain hex M8	(12)
12	G1	5310-99-122-6475	Washer flat M8	(6)
8.3 <u>Stores to be modified:</u>				
13	9ACR	2510-99-867-4629 (FV 559953)	Cover assy (lower)	1

**WARNING**

**ASBESTOS. DUE TO THE POSSIBILITY OF ASBESTOS ON THE INTERNAL SURFACE (ENGINE SIDE) OF COVER FV 559953. PROTECTIVE CLOTHING SHOULD BE WORN, ESPECIALLY GLOVES AND FACE MASK WHEN DRILLING AND HANDLING DURING THE MODIFICATION.**

**Sequence of operations****NOTE**

The 'item numbers' of Para 8 are used as references throughout this instruction.

**9 Carry out the modification as follows:**

Refer to Fig 1 and 2

9.1 Remove engine cover (FV 559953), mark out and drill holes in cover refer to Fig 1.

9.2 Attach barrel and butt clips (items 3 and 4) to brackets (items 1 and 2) using (items 5, 6, 8, 9, 10, 11 and 12) see Fig 2 for location and quantity required.

9.3 Attach brackets (items 1 and 2) to engine cover using (items 6, 7, 9 and 11) see Fig 2 for location and quantity required.

**Testing after embodiment**

10 Nil.

**EFFECT ON WEIGHT**

11 Nil.

**PUBLICATION AMENDMENTS**

**NOTE**

Necessary amendments will be issued separately.

12 Nil.

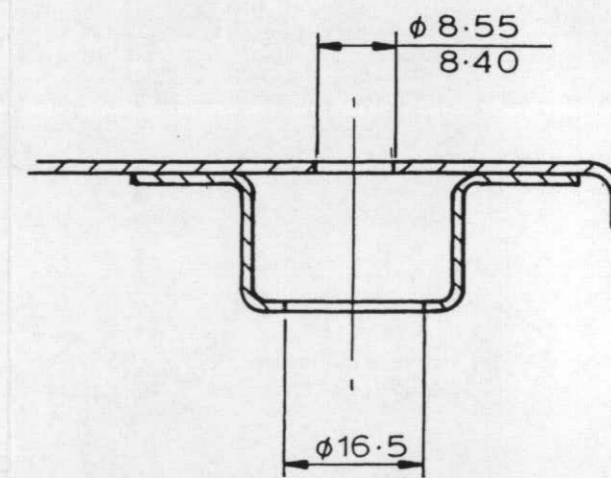
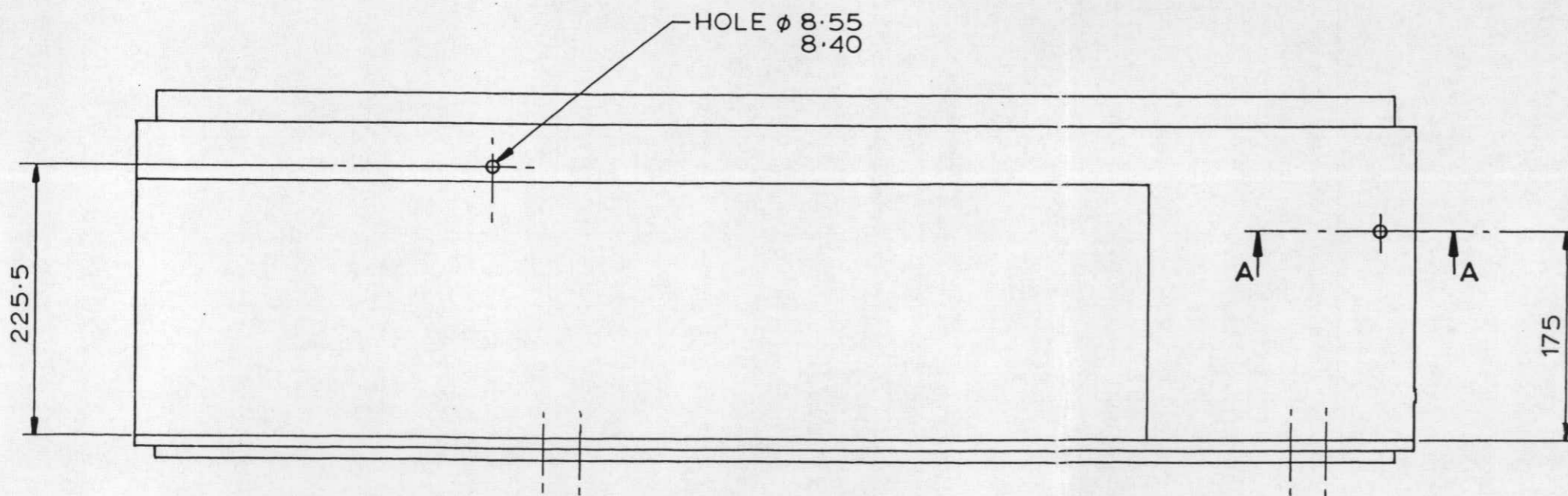
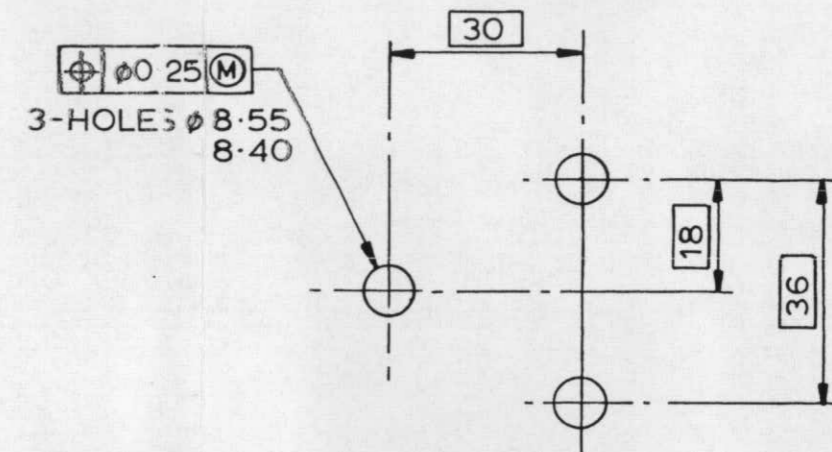
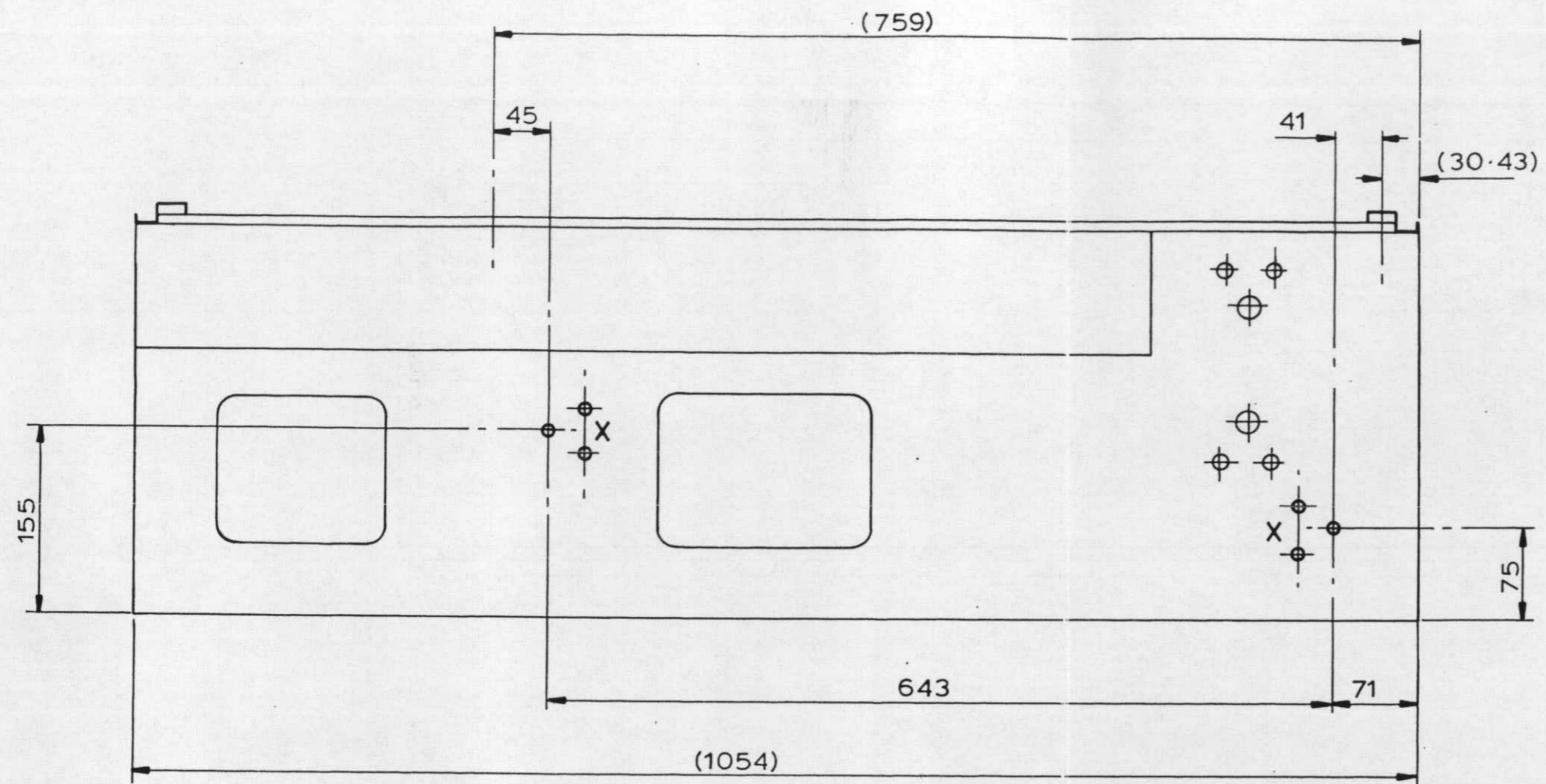

Fig 1 Engine cover (FV 559953)

SECTION A-A

V12891/1

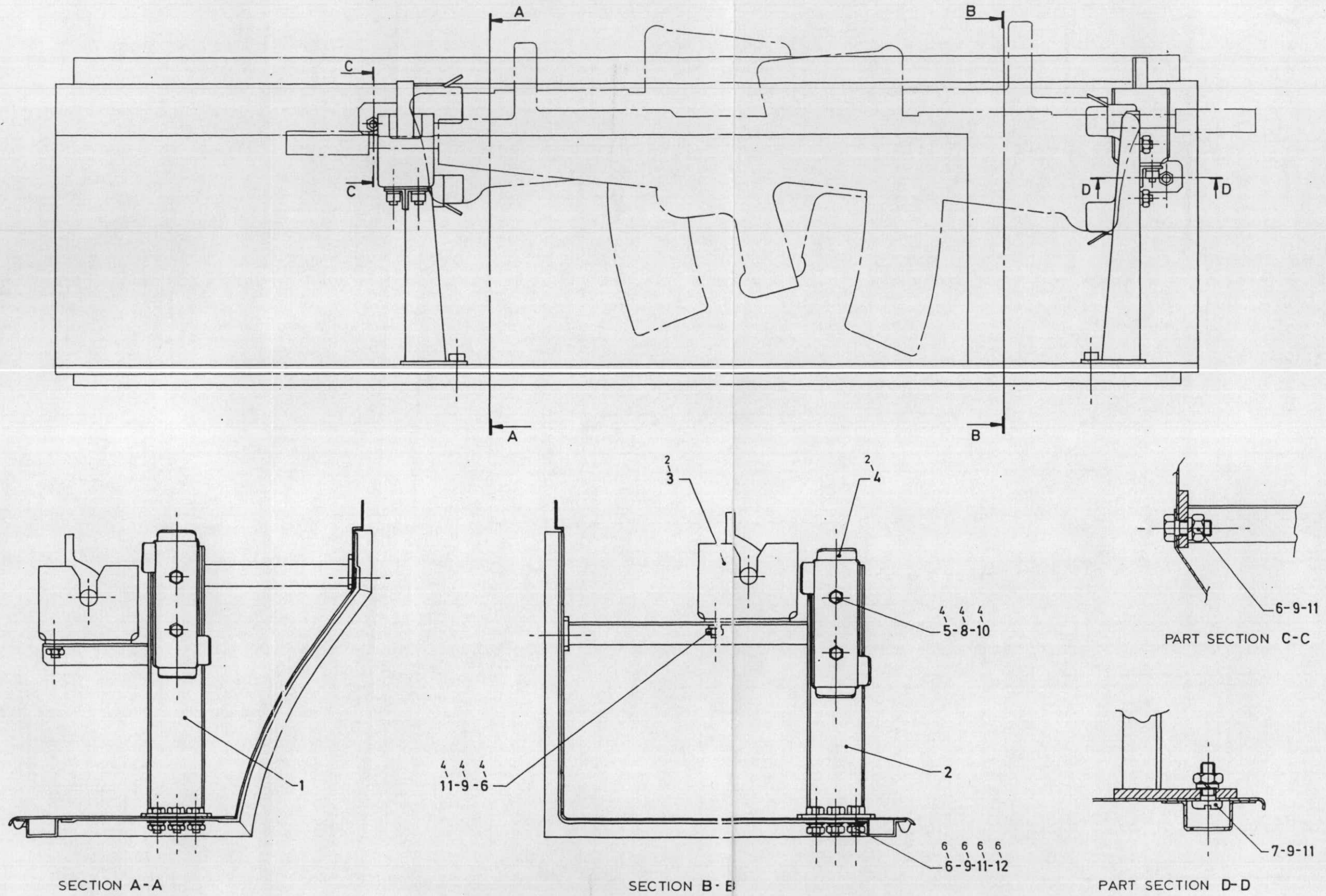

Fig 2 General arrangement of brackets and clips

V12891/2

CONDITIONS OF RELEASE

- |   |   |
|---|---|
| 1 This information is released by the UK Government to the recipient Government for Defence purposes only.                | 3 This information may be disclosed only within the Defence Department of the recipient Government, except as otherwise authorized by Ministry of Defence (Army). |
| 2 This information must be accorded the same degree of security protection as that accorded thereto by the UK Government. | 4 This information may be subject to privately owned rights.  |

THIS DOCUMENT IS THE PROPERTY OF HER BRITANNIC MAJESTY'S GOVERNMENT, and is issued for the information of such persons only as needed to know its contents in the course of their official duties. Any person finding this document should hand it into a British forces unit or to a police station for its safe return to the MINISTRY OF DEFENCE D.MOD Sy LONDON SW1A 2HB with particulars how and where found. THE UNAUTHORIZED RETENTION OR DESTRUCTION OF THIS DOCUMENT IS AN OFFENCE UNDER THE OFFICIAL SECRETS ACTS OF 1911-1989. (When released to persons outside government service, this document is issued on a personal basis and the recipient to whom it is entrusted in confidence within the provision of the Official Secrets Acts 1911-1989, is personally responsible for its safe custody and for seeing that its contents are disclosed only to authorized persons).

**CARRIER, FULL TRACKED, MK 2 AND 2/1, FV432**

**TECHNICAL HANDBOOK - MODIFICATION INSTRUCTION**

**SUBJECT: Amber Rotating Beacon**

(Approval No. 43/2/0008)

**INTRODUCTION**

1 This instruction details the fitment of an amber rotating beacon to warn other road users of a slow moving vehicle.

**APPLICABILITY**

2

2.1 Carrier, Personnel, Full Tracked, Mk 2, 2/1.

2.2 Unmodified stock held at all levels of technical storage.

**REASON FOR MODIFICATION**

3 Code 1 - to improve safety.

**PRIORITY**

4 Immediate.

**ESTIMATED TIME REQUIRED**

5 Embodiment: 2 man-hours.

**MODIFICATION IMPLEMENTATION PLAN**

6

6.1 This modification is to be implemented by units authorized to carry out levels 2, 3 and 4 maintenance.

72211(238)  
ATSA Chertsey

9707WCP-2404  
Nov 97, Issue 2 (23X)

6.2 Associated modification instructions. EMER Tracked Vehicles E 107/2 No. 139 mini pipe fascine.

Action required by:

7

7.1 Units and establishments holding equipment:

7.1.1 Examine documents to see if modification is applicable.

7.1.2 Examine equipment or modification record plate to see if modification is embodied.

7.1.3 Record the modification subject and EMER number in equipment documents.

7.2 Army units authorized to carry out levels 2, 3 and 4 maintenance:

7.2.1 When requested by users or during overhaul of equipment, obtain the items listed in Para 8 and carry out this modification.

7.2.2 Record completion details of modification against appropriate entry in vehicle documents.

7.3 All recipients of this instruction. Add particulars to EMER E 107/2 Mod Instr Index.

Stores, tools and equipment

8

8.1 Stores to be demanded:

8.1.1 The following items are to be demanded quoting this instruction as authority for demand.

8.1.2 Registration/Serial number of vehicle held by user units.

Item No.	DMC	NSN/Part No.	Designation	Qty per eqpt
	9ACR	2540-99-301-7175	Mod set comprising: "	1
1		<del>BEACON</del> 6220-99-838-5622 COMPLETE ASSY FV 2200650	Beacon amber rotating.	(1)
2		2540-99-127-3008 FV 2200644	Base assy-rotating.	(1)
3		2540 99 942 0427 FV 2200642	Harness ext lead - mini fascine to base assy.	(1)
4	X5	6240-99-995-2519	BULB HI 24V (BRITAX H460)	
5				
6				
7	6MT4	5340-99-838-1364	Tie cable releasable.	(8)
8	G1	5306-99-122-5253	Screw hex hd M8 x 30 lg 8.8 zp.	(4)

REFER TO  
FV 434



Item No.	DMC	NSN/Part No.	Designation	Qty per eqpt
9		5310-99-139-0313	Nut hex thin M8-8 zp.	(4)
10		5310-99-138-9227	Washer spring s/coil M8.	(4)
11		5310-99-138-7965	Washer plain M8 large o.d.	(4)
8.2	<u>Stores or suitable equivalent to be obtained locally.</u>			
12	G1	5315-99-139-5252	Pin, 6 mm x 40.5 lg	(1)

8.3 Stores to be removed and retained. All units that have a beacon fitted that is not Design Authority (DA) approved should remove the beacon and fit the approved modification, retaining locally all those parts that are compatible for use as spares.

### Sequence of operations

9 Carry out the modification as follows:

#### NOTES

- (1) The item numbers quoted in brackets refer to those listed in Para 8 of this instruction.
- (2) Before fitting this modification, the mini pipe fascine modification E107/2 Mod Instr No. 139, must be carried out to provide a power source for the beacon.
- Refer to Fig 1
- 9.1 Drill holes as indicated.
- Refer to Fig 2
- 9.2 Bolt mounting bracket base (item 2) in position using (items 8, 9, 10 and 11).
- 9.3 Fit roll pin (item 12) in pre-drilled hole, in bracket base (item 2).
- 9.4 Fit and secure cable (item 3) with straps (item 7) as indicated in Fig 1 and 2. Plug into socket by rear lights.
- 9.5 Fit amber beacon (item 1) and connect cable (item 3), to mini fascine socket.

### TESTING AFTER EMBODIMENT

10 Switch on lights and check that amber beacon is operating correctly.

### EFFECT ON WEIGHT

11 Negligible.

### PUBLICATION AMENDMENTS

#### NOTE

Necessary amendments will be issued separately.

12 Nil.

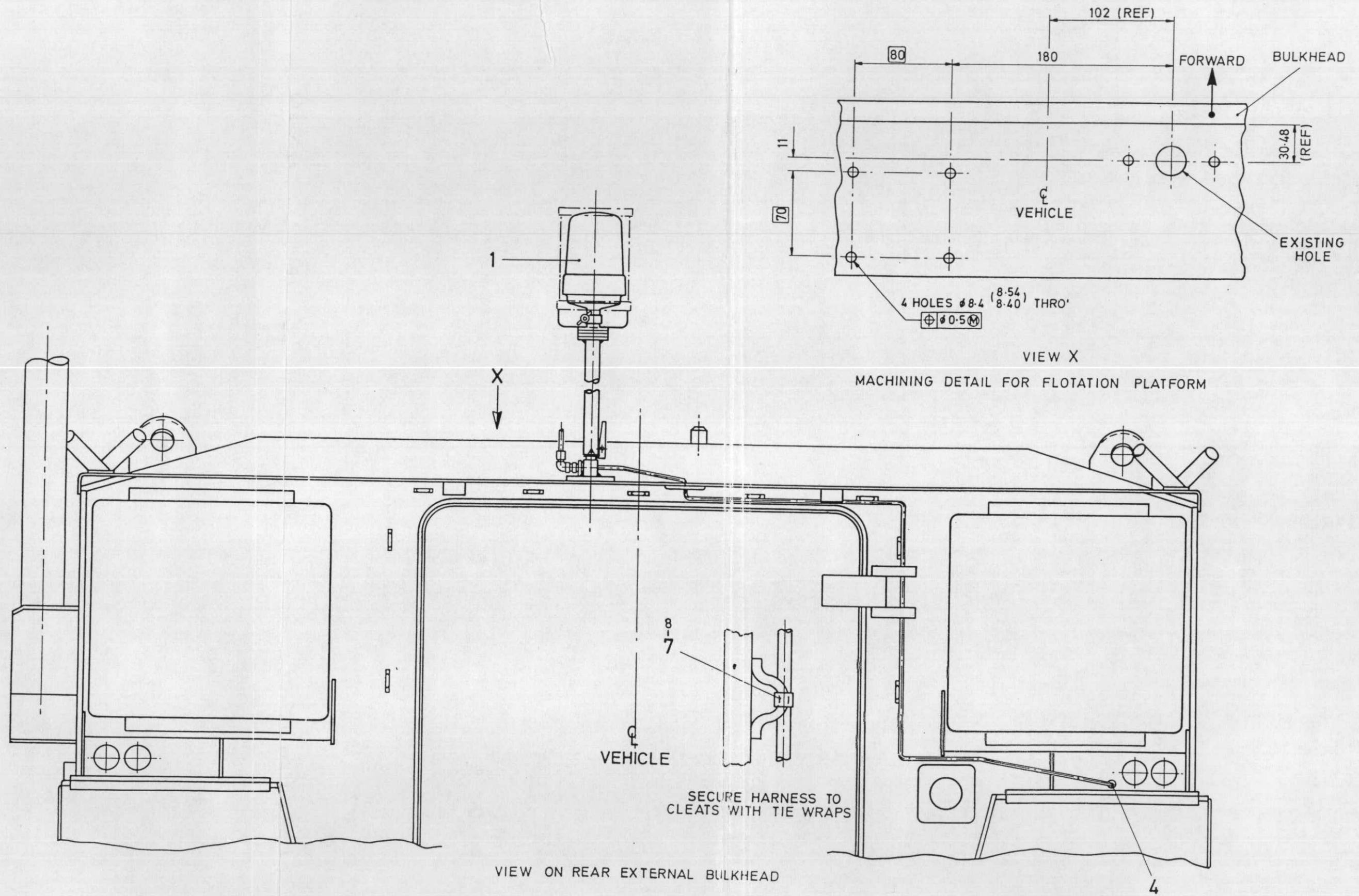

Fig 1 Machining details

V13889/2

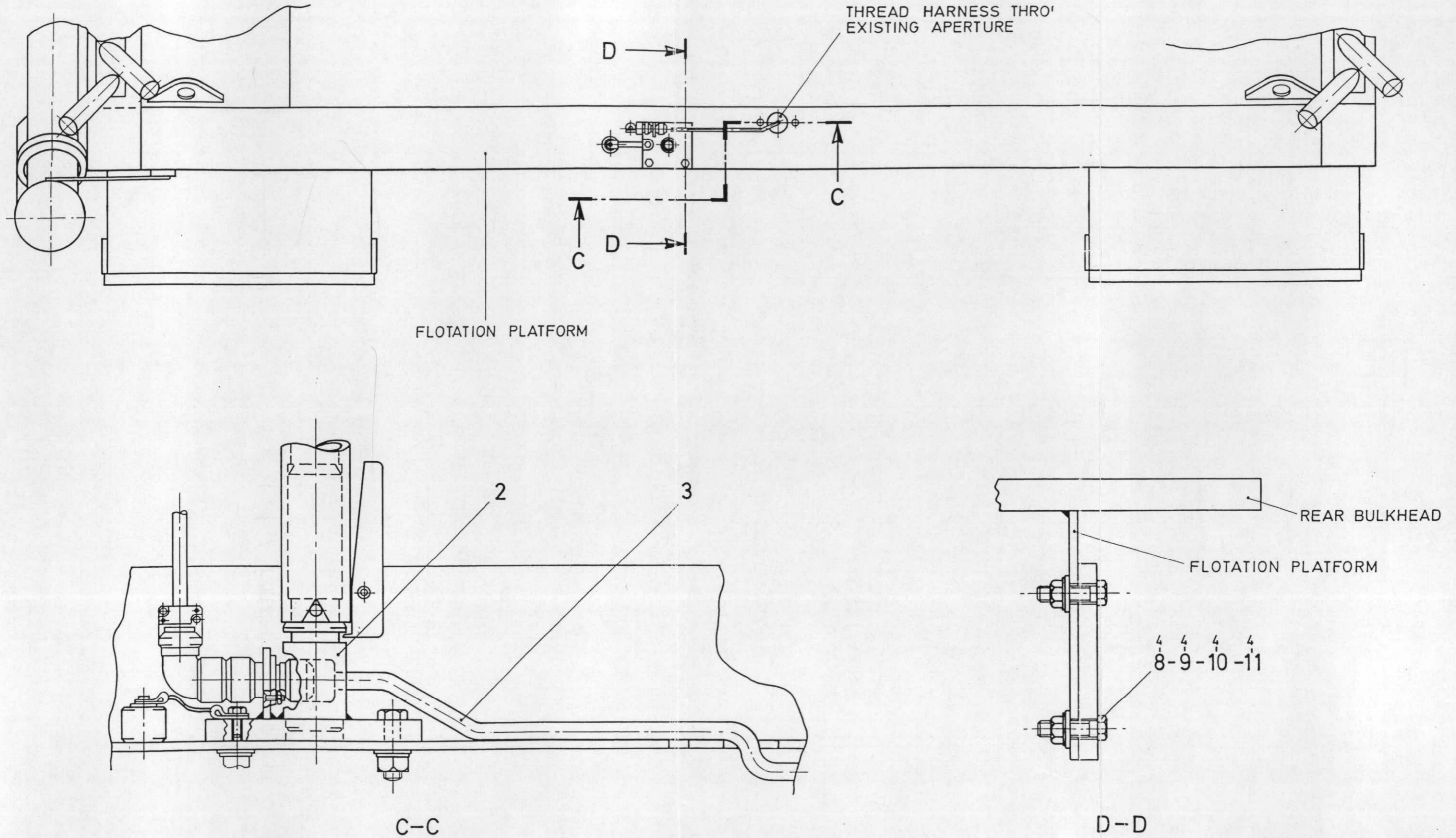

Fig 2 Beacon mounting details

**CARRIER, FULL TRACKED, FV432 MK 2 AND 2/1**

**MODIFICATION INSTRUCTION NO. 2**

Sponsor:  
DGES(L)

Publication Agency:  
DLO Chertsey  
Project No: S01008(346)  
File ref:

**AMENDMENT RECORD**

Amdt No.	Incorporated By (Signature)	Date
1		
2		
3		

Amdt No.	Incorporated By (Signature)	Date
4		
5		
6		

**SUBJECT: Fuel tank filter**

(Approval No. 43/0/0046)

**INTRODUCTION**

1 This instruction introduces the installation of a fuel strainer element to the fuel tank filler cap to reduce fuel contamination.

1.1 Limitations on use of equipment. Nil.

**APPLICABILITY**

2 Unmodified stock, held at all levels of technical storage.

**REASON FOR MODIFICATION**

3 Code 4 - to improve maintainability.

**PRIORITY**

4 Routine.

**ESTIMATED TIME REQUIRED**

5 Embodiment: 0.15 man-hour.

**MODIFICATION IMPLEMENTATION PLAN**

6

6.1 This instruction is to be implemented by:

6.1.1 Units authorized to carry out levels 2, 3 or 4 maintenance.

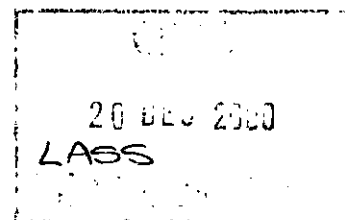

**Action required by**

7

**7.1 Units and establishments holding equipment:**

7.1.1 Examine equipment documents to see if modification is applicable.

7.1.2 Examine equipment or modification record plate to see if modification is embodied and where necessary Units with 1st Line REME Support demand the stores required.

7.1.3 On receipt of stores, request REME to modify equipment.

7.1.4 Record the AESP and instruction number in equipment documents.

**7.2 Army units authorized to carry out levels 2, 3 and 4 maintenance:**

7.2.1 When requested by units or during overhaul of equipment on charge without REME 1st Line Support, obtain the items listed in Para 8 and carry out this modification.

7.2.2 Record completion details of modification against appropriate entry in vehicle documents.

**7.3 All recipients of this instruction. Add particulars to AESP2350-T-251-811 Instr Index.****Stores, tools and equipment**

8

**8.1 Stores to be demanded:**

8.1.1 The following item is to be demanded quoting this instruction as the authority.

8.1.2 Registration/Serial number of vehicle/engine/assembly for equipment held by user units.

Item No.	DMC	NSN/Part No.	Designation	Qty per eqpt
1	9ACR	2910-99-866-5448	Strainer element.	2

**Sequence of operations****NOTE**

The item numbers of Para 8 are used as reference throughout this instruction.

**9 Carry out this instruction as follows:**

Refer to Fig 1

9.1 Remove fuel filler cap from left hand fuel tank. Remove circlip (item 2).

9.2 Fit fuel filter (item 1). Refit circlip (item 2). Refit fuel filler cap.

9.3 Repeat Sub-Para 9.1 and 9.2 for right hand fuel tank.

**TESTING AFTER EMBODIMENT**

10 Nil.

**EFFECT ON WEIGHT**

11 Negligible.

**PUBLICATION AMENDMENTS**

**NOTE**

Necessary amendments will be issued separately.

12 Nil.

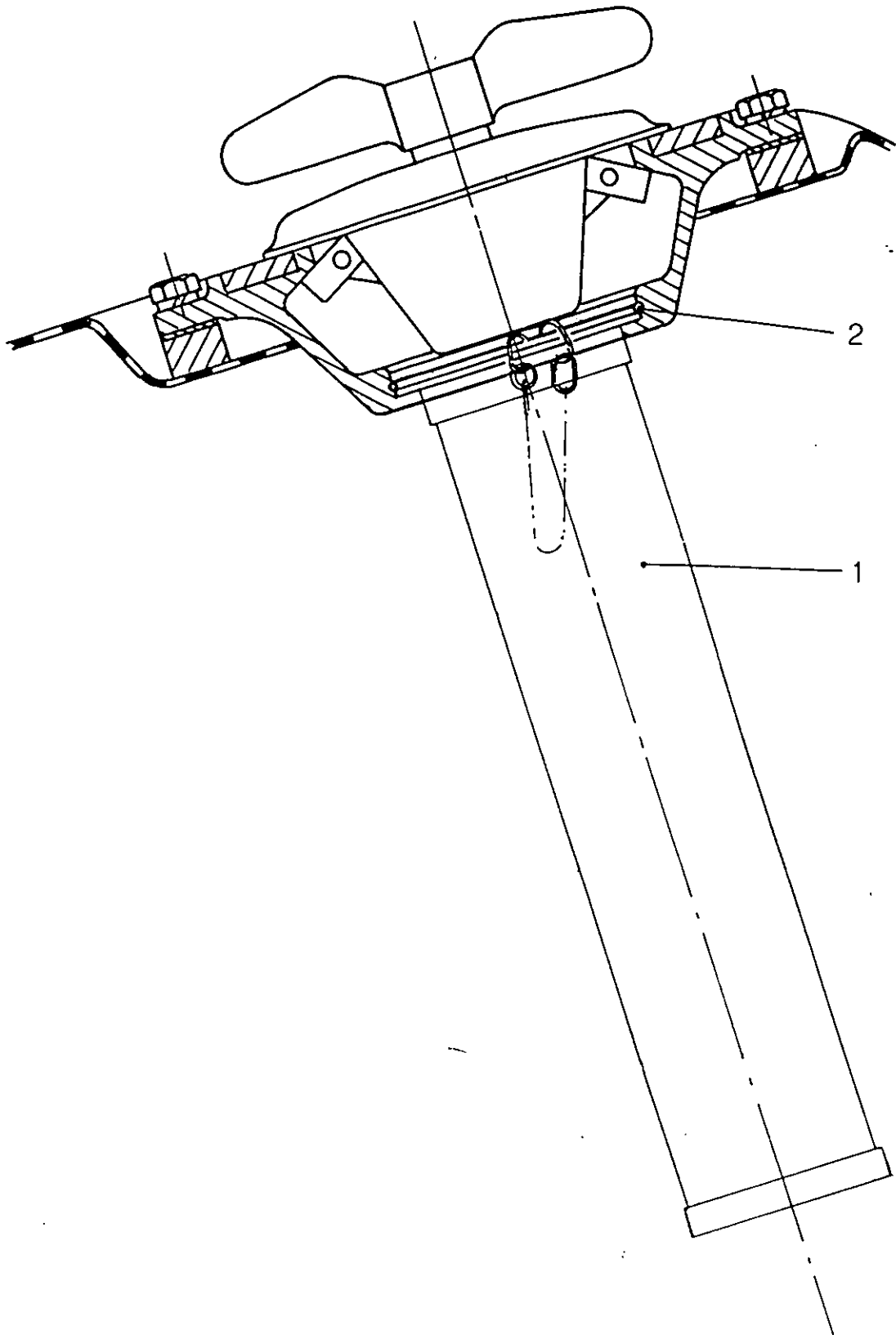

V14634/1

Fig 1 Fuel tank filter

**CARRIER, FULL TRACKED, FV432 MK 2 AND 2/1**  
**MODIFICATION INSTRUCTION NO. 3**

Sponsor:  
DGES(L)

Publication Agency:  
DLO Andover  
Project No: S01008( )  
File ref: 43/2/0017

**AMENDMENT RECORD**

Amdt No.	Incorporated By (Signature)	Date
1		
2		
3		

Amdt No.	Incorporated By (Signature)	Date
4		
5		
6		

**SUBJECT: High visibility marker boards**

(Approval No. 43/2/0017)

**INTRODUCTION**

1 This instruction introduces the fitment of two high visibility marker boards to the stowage bins mounted either side of the rear door of the vehicle. The marker boards can be reversed to show green/black to match the vehicle when required.

1.1 Limitations on use of equipment. Nil.

**APPLICABILITY**

2 Unmodified stock, held at all levels of technical storage.

**REASON FOR MODIFICATION**

3 Code 1 - to improve safety.

**PRIORITY**

4 Immediate.

**ESTIMATED TIME REQUIRED**

5 Embodiment: 1.0 man-hour.

**MODIFICATION IMPLEMENTATION PLAN**

6

6.1 This instruction is to be implemented by:

6.1.1 Units authorized to carry out levels 2, 3 or 4 maintenance.

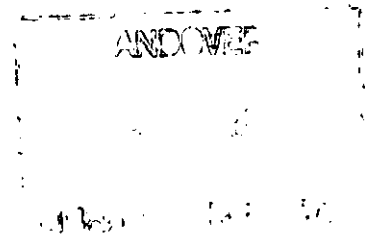



**Action required by**

7

**7.1 Units and establishments holding equipment:**

7.1.1 Examine equipment documents to see if modification is applicable.

7.1.2 Examine equipment or modification record plate to see if modification is embodied and where necessary Units with 1st Line REME Support demand the stores required.

7.1.3 On receipt of stores, request REME to modify equipment.

7.1.4 Record the AESP and instruction number in equipment documents.

**7.2 Army units authorized to carry out levels 2, 3 and 4 maintenance:**

7.2.1 When requested by units or during overhaul of equipment on charge without REME 1st Line Support, obtain the items listed in Para 8 and carry out this modification.

7.2.2 Record completion details of modification against appropriate entry in vehicle documents.

7.2.3 When the Modification has been embodied, complete and return Annex A.

**7.3 All recipients of this instruction. Add particulars to AESP 2350-T-251-811 Instr Index.****Stores, tools and equipment****NOTE**

If high visibility rear marker plates are fitted to the vehicle, and are of the same pattern as item 1, carefully remove and re-use the marker plates.

8

**8.1 Stores to be demanded:**

8.1.1 The following items are to be demanded quoting this instruction as the authority.

8.1.2 Registration of vehicle for equipment held by user units.

Item No.	DMC	NSN/Part No.	Designation	Qty per eqpt
1	6MT1	9905-99-837-2954	Marker plate (pair)	1
2	9ACR	2540-99-815-0156	Holder assembly	2

**8.2 Stores or suitable equivalent to be obtained locally:**

3	G1	5305-99-122-5360	Screw hex hd M6 x 16 lg	8
4	G1	5310-99-122-5295	Nut hex M6	8
5	G1	5310-99-137-9232	Washer spring M6	8

8.3 Items/stores to be modified:

6	FV 586548	L/H and R/H stowage bin doors	2
---	-----------	-------------------------------	---

**Sequence of operations**

**NOTE**

The item numbers of Para 8 are used as reference throughout this instruction.

9 Carry out this instruction as follows:

**WARNING**

**PAINT PROCESSES TO BE CARRIED OUT IAW AESP 0200-A-221-013 FOLLOWING ALL NECESSARY SAFETY PRECAUTIONS**

9.1 Paint, to current regulations, the rear surface of the marker plates (item 1) green/black to match rear stowage bins.

Refer to Fig 1

9.2 Drill holes as indicated in both of the stowage bin doors (item 6).

9.3 Fit holder assembly (item 2) to left hand stowage bin door (item 6) using fittings (item 3, 4 and 5), ensuring that opening for the marker plates (item 1) is at the top. Repeat for right hand stowage bin door.

9.4 Fit the marker plates (item 1) in to the holder assemblies (item 2).

**TESTING AFTER EMBODIMENT**

10 Nil.

**EFFECT ON WEIGHT**

11 Negligible.

**PUBLICATION AMENDMENTS**

**NOTE**

Necessary amendments will be issued separately.

12 Nil.

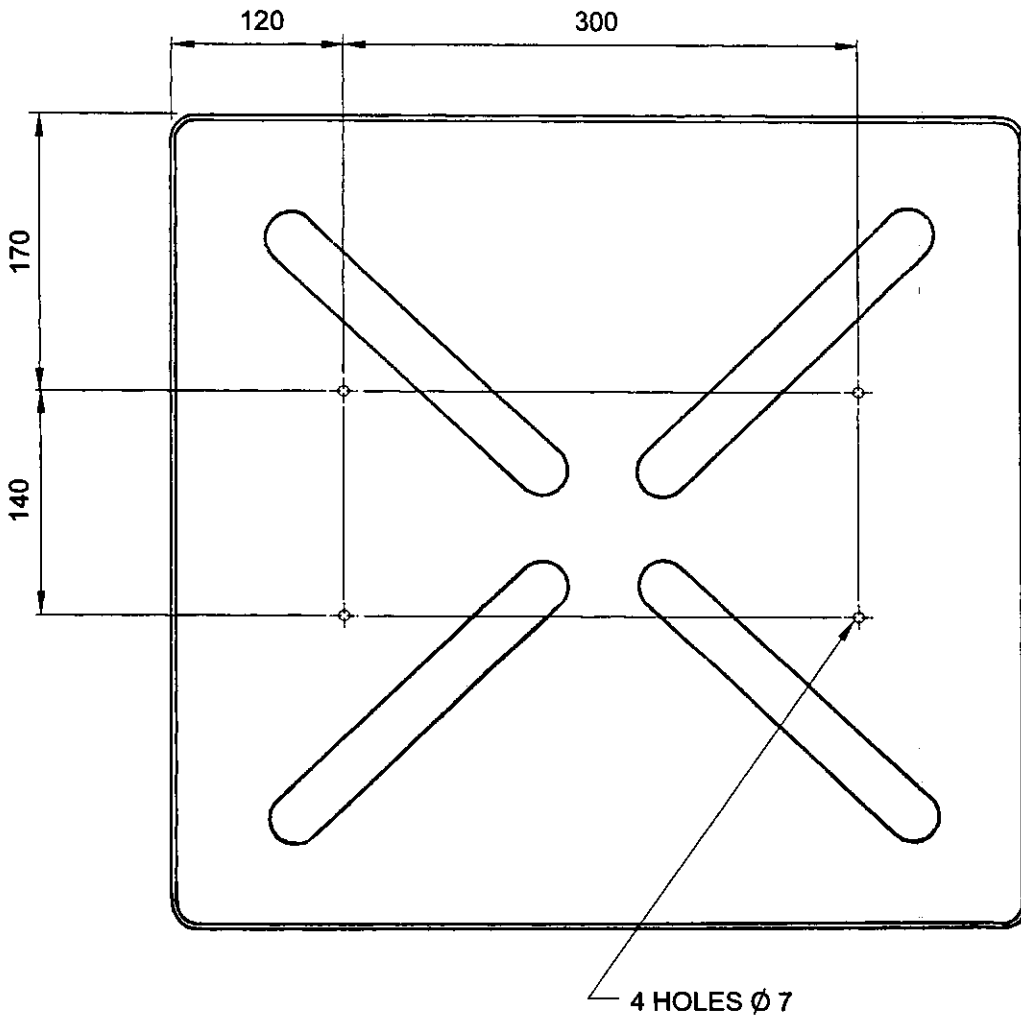

DIMENSIONS IN mm

V14963/1

Fig 1 Rear stowage bin door

**MODIFICATION INSTRUCTION NO. 3**

**ANNEX A**

To enable accurate modification records to be maintained for all FV430 series vehicles, all units are to complete and return this form when the modification has been embodied. Multiple equipment returns can be submitted.

FV430 ESM LASS IPT DLO Monxton Road Andover Hampshire SP11 8HT
---

From:

Unit:	UIN:
Name:	Signature:

Modification No. 3

Date embodied:

Vehicle registration number(s)

UNRESTRICTED

UNRESTRICTED

CARRIER, FULL TRACKED, FV432 MK 2 AND 2/1  
MODIFICATION INSTRUCTION NO. 4

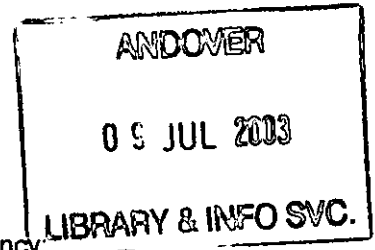

Sponsor:  
DGES(L)

Publication Agency:  
DLO Andover  
Project No: S01008( )  
File ref:

**AMENDMENT RECORD**

Amdt No.	Incorporated By (Signature)	Date
1		
2		
3		

Amdt No.	Incorporated By (Signature)	Date
4		
5		
6		

**SUBJECT:** Rear floor plate

(Approval No. 43/0/0060)

**INTRODUCTION**

1 This instruction introduces a removable section of the rear floor plate to improve access to the fuel collector tank and fuel pump.

1.1 Limitations on use of equipment. Nil.

**APPLICABILITY**

2 Unmodified stock, held at all levels of technical storage.

**REASON FOR MODIFICATION**

3 Code 4 - to improve maintainability.

**PRIORITY**

4 Routine.

**ESTIMATED TIME REQUIRED**

5 Embodiment: 1.5 man-hours.

**MODIFICATION IMPLEMENTATION PLAN**

6

6.1 This instruction is to be implemented by:

6.1.1 Units authorized to carry out levels 2, 3 or 4 maintenance.

**Action required by**

7

7.1 Units and establishments holding equipment:

7.1.1 Examine equipment documents to see if modification is applicable.

7.1.2 Examine equipment to see if modification is embodied and where necessary Units with 1<sup>st</sup> Line REME Support demand the stores required.

7.1.3 On receipt of stores, request REME to modify equipment.

7.1.4 Record the AESP and instruction number in equipment documents.

7.2 Army units authorized to carry out levels 2, 3 and 4 maintenance:7.2.1 When requested by units or during overhaul of equipment on charge without REME 1<sup>st</sup> Line Support, obtain the items listed in Para 8 and carry out this modification.

7.2.2 Record completion details of modification against appropriate entry in vehicle documents.

7.3 All recipients of this instruction. Add particulars to AESP 2350-T-251-811 Instr Index.**Stores, tools and equipment**

8

8.1 Stores or suitable equivalent to be obtained locally:

Item No.	DMC	NSN/Part No.	Designation	Qty per eqpt
1	G1	5305-99-941-1748	Screw csk hd, ¼" UNF	8
2	6MT6	9320-99-087-1288	Rubber sheet, 1/16 in thk x 36 in wide. (approx 6 in length required, to be cut into 2 in strips)	as req
3	H1ATS	8040-99-943-6957	Adhesive, Evostick 528	as req

8.2 Items/stores to be modified:

4	9ACR	2510-99-867-4642	Rear floor plate	1
---	------	------------------	------------------	---

**Sequence of operations**

## NOTE

The item numbers of Para 8 are used as reference throughout this instruction:

9 Carry out this instruction as follows:

Refer to fig 1.

- 9.1 Remove rear floor plate (item 4), qty 3 insulation pads and qty 2 access plates (FV 585923).
- 9.2 Mark out and cut rear floor plate as indicated.
- 9.3 Mark out, drill and countersink the eight additional fixings in both sections of rear floor plate.
- 9.4 Refit and secure both sections of rear floor plate (item 4) in the hull. Spot the eight additional fixings in the hull. Remove both sections of the rear floor plate (item 4), drill and tap the additional fixings to suit.
- 9.5 Fit rubber strip (item 2) to the hull where the floor plate will fit using adhesive (item 3).
- 9.6 Fit and secure rear floor plate (item 4) using screws (item 1).

#### **TESTING AFTER EMBODIMENT**

10 Nil.

#### **EFFECT ON WEIGHT**

11 Negligible.

#### **PUBLICATION AMENDMENTS**

#### **NOTE**

Necessary amendments will be issued separately.

12 Nil.



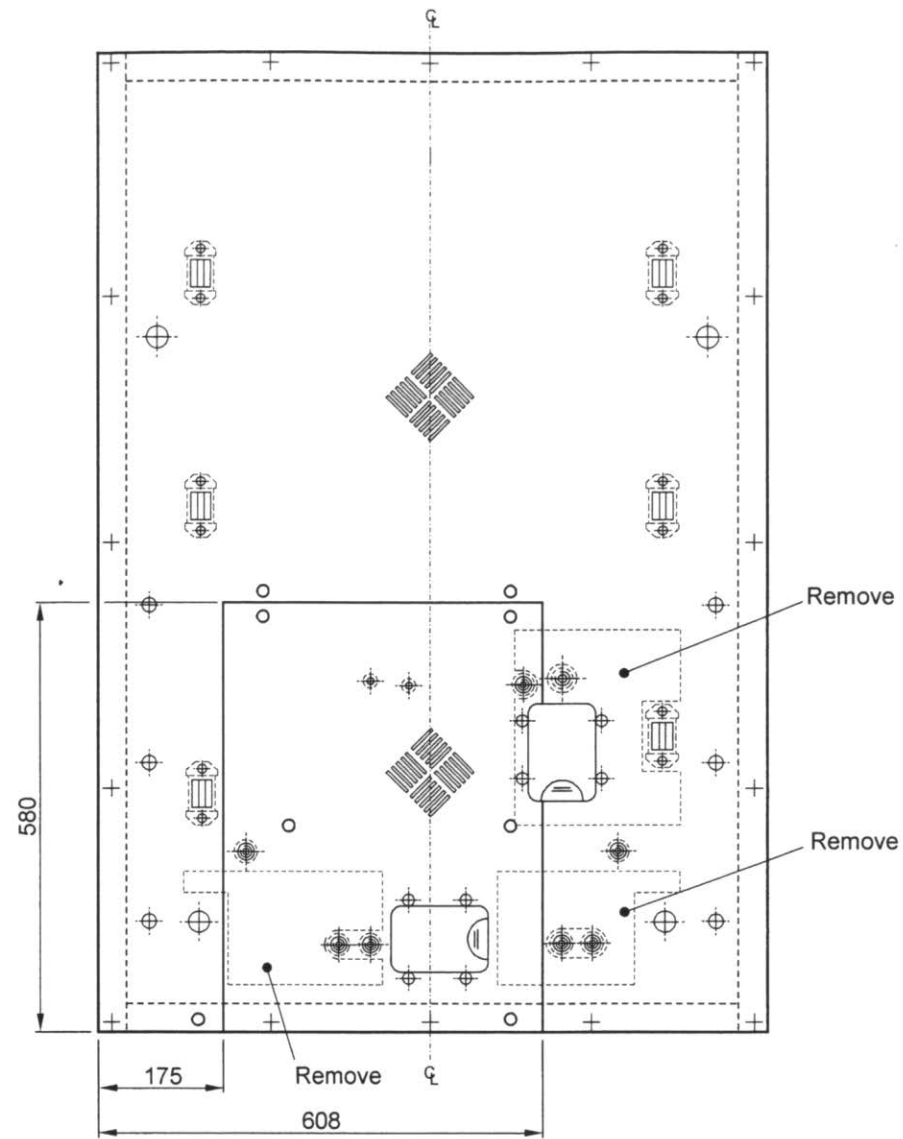

VIEW ON FLOOR PLATE SHOWING CUTTING DETAILS

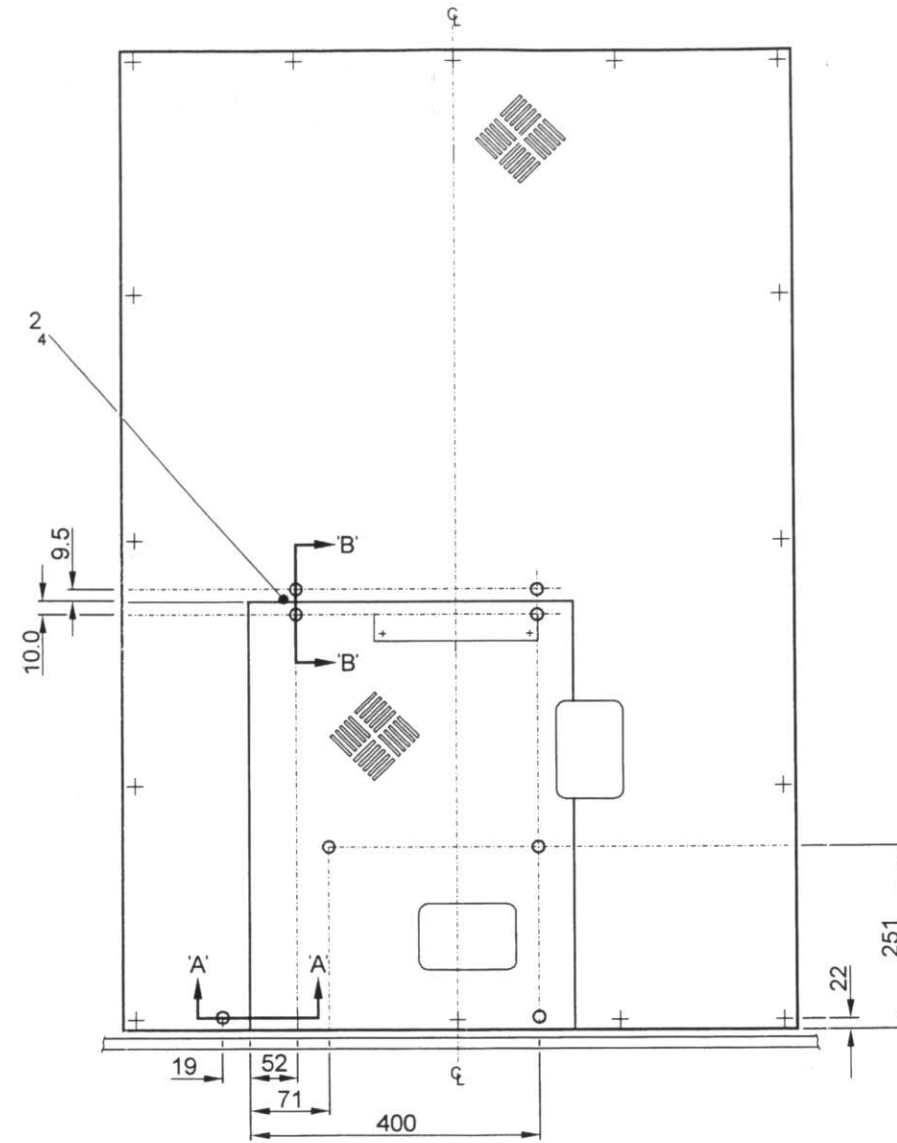

VIEW ON FLOOR PLATE SHOWING NEW FIXINGS

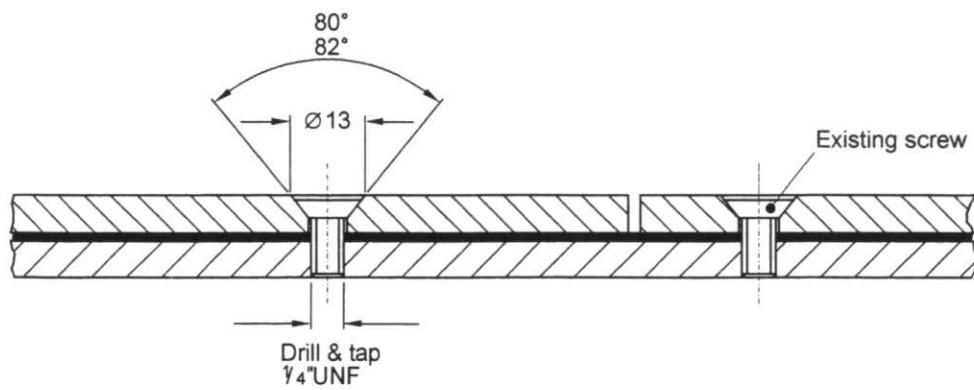

SECTION 'A'-A'

Additional fixings  
drill 7.2 Dia &  
Csk 13mm

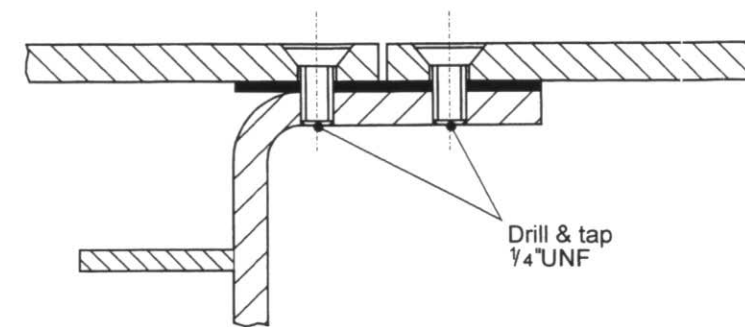

SECTION 'B'-B'

Dimensions in MM

V15027/1

Fig 1 Rear floor plate modification detail

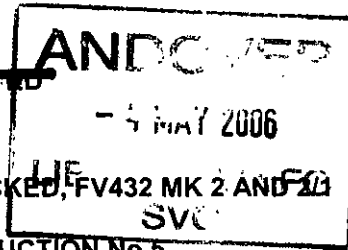

**CARRIER PERSONNEL, FULL TRACKED, FV432 MK 2 ANDOVER  
MODIFICATION INSTRUCTION No 5**

Sponsor: LASS IPT DLO Andover

Publication Agency: BAES (Land Systems)

Project No:

File Ref: DGES (L) 13/5

**AMENDMENT RECORD**

Amdt No.	Incorporated By (Signature)	Date
1		
2		
3		

Amdt No.	Incorporated By (Signature)	Date
4		
5		
6		

**SUBJECT: Introduction of crew lap belts.**

Approval No: MAE 43/2/0020 (All variants less Mortar)  
MAE 43/2/0023 (Mortar)

**INTRODUCTION**

1 This instruction details the procedures for the embodiment of crew seat belts into the FV432 range of vehicles. Lap belts are provided to restrain crew members travelling in the rear compartment in the event of a road traffic accident. Lap belts are mounted on a standard bracket, which is sandwiched behind the seat mounting brackets, according to the travelling configuration layout.

1.1 Limitations on use of equipment. Nil.

**APPLICABILITY**

2 The modification is applicable to all roles of the FV432 identified below:

2.1 Armoured Personnel Carrier.

2.2 Command Post.

2.3 Ambulance (2 Stretcher configuration).

2.4 Mortar.

2.5 ASP.

**REASON FOR MODIFICATION**

3 Code 1 – To improve safety.

**PRIORITY**

4 Immediate.

**ESTIMATED TIME REQUIRED**

5 Embodiment. Dependant upon variant (20 min per bracket).

**MODIFICATION IMPLEMENTATION PLAN**

6

6.1 This modification plan is to be implemented by units authorised to carry out levels 2, 3 and 4 maintenance.

6.2 Associated modification instructions AESP 2350-T-251-811 Mod Instr No 1 (EMER TV E 107/2 Mod Instr No 116).

6.3 Modification strike plate action: N/A.

**Action required by**

7

7.1 Units and establishments holding equipment.

7.1.1 Ensure applicability and demand the stores required.

7.1.2 On receipt of stores, request Level 2 Maintenance Support to modify the equipment.

7.1.3 Record the modification subject and AESP No. in vehicle AB413.

7.2 Army units authorised to carry out levels 2, 3, and 4 maintenance.

7.2.1 When requested by the users, obtain the items listed in Para 8 and carry out this instruction.

7.2.2 Record completion details in vehicle AB413.

7.3 All recipients of this instruction.

7.3.1 Add particulars to AESP 2350-T-251-811 Mod Instr Index.

**Stores, tools and equipment**

8

8.1 Table 1 - Stores to be demanded for all roles except Mortar.

8.1.1 Each kit contains Qty 2 seat belts and Qty 1 support plate. Therefore units should demand Qty 1 kit for each double seat location.

8.1.2 The following kit is to be demanded quoting this instruction and the vehicle registration number as the authority for demand.

Item No	NSN / Part No	Drawing No or Reference No	Designation	Qty
1	2540-99-212-8099	MAE 43/2/0020	Kit Lap Belt (comprising of)	As reqd
2	2540-99-549-5386	FV2249146	Lap Belt	2
3	5305-99-941-0568		1/2 in. UNF X 1-1/4 in. Screw	4
4	5310-99-941-8637		1/2 in. Plain washer	8
5	5310-99-912-9584		1/2 in. Lock washer	4
6	2540-99-690-7049	FV2249173	Assy Plate Support Lap Belts	1

8.2 Table 2 - Stores to be demanded for Mortar.

8.2.1 Units should demand per vehicle Qty 1 Kit Lap Belt NSN 2540-99-212-8099 and additionally the following Kit Lap Belt Mortar quoting this instruction and the vehicle registration number as the authority for demand.

Item No	NSN / Part No	Drawing No or Reference No	Designation	Qty
1	2540-99-219-6761	MAE 43/2/0023	Kit Lap Belt Mortar (comprising of)	1
2	2540-99-549-5386	FV2249146	Lap Belt	2
3	5305-99-941-0568		1/2 in. UNF X 1-1/4 in. Screw	4
4	5310-99-941-8637		1/2 in. Plain washer	8
5	5310-99-912-9584		1/2 in. Lock washer	4
6	2540-99-690-7049	FV2249173	Assy Plate Support Lap Belts	1
7	2540-99-147-6604	FV2249175	Frame lap belts WA .	1
8	5305-99-941-6292		Screw Hex Hd 3/8 in. UNF X 1-1/4 <sup>1/2</sup> in.	6
9	5310-99-135-2066		Washer Spring single coil 3/8 in. Type B	6
10	5310-99-135-1536		Washer Plain 3/8" dia	6

8.3 Table 3 - Items to be retained.

Item No	NSN / Part No	Drawing No or Reference No	Designation	Qty
1	5310-99-941-0928		Nut Hex 1/2 in. UNF	4 per seat
2	5310-99-944-0552		Spring Washer 1/2 in. dia	4 per seat

**Sequence of operations**

9 Carry out the modification as follows:

9.1 Remove the relevant personnel seats at the rear of the vehicle retaining items 1 & 2 of Table 3.

9.2 Attach the lap belts to the bracket using the 1/2 in. UNF X 1-1/4 in. screws with plain washers each side of the belt anchorage tabs and a lock washer under the head of the screw (Items 3, 4 & 5).

9.3 The lap belt bracket assembly (Fig 1) is secured behind the (upper) seat mounting brackets on the four studs welded to the hull. Position the lap belt bracket, replace the seat mounting bracket and secure with the retained nuts and washers.

**NOTE**

Some cutting away of the foam insulation may be required to ensure a flush fit of the bracket on the studs.

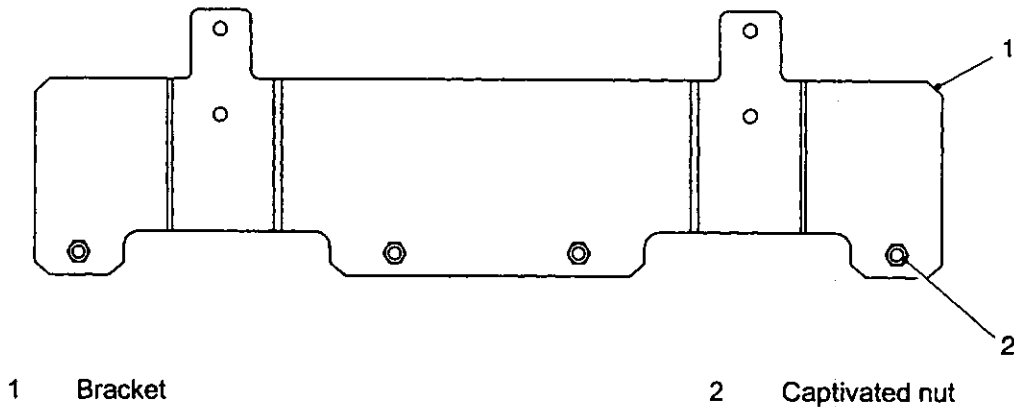

432/534

Fig 1 Seat belt bracket (Rear View)

10 The belts should be fitted in such a manner that they are biased towards their other half.

#### Mortar variant

11 Ensure the Mortar variant vehicle has its ventilation batteries reverted to their old position in the left hand corner of crew area behind power pack bulkhead. (Sub-Para 6-2 refers).

12 The lap belt bracket (Fig 1) for the double seat is mounted onto an adaptor bracket item 3 (Fig 2), which is fixed to the engine compartment bulkhead.

13 The lap belt for the single seat is attached to a standard fitting bracket (Fig 1) located at the front right hand side of the personnel compartment (behind the commanders seat). The seat belt stalk (Fig 2(5) and reel (2) are then fixed to the bracket (4) using the 1<sup>st</sup> and 3<sup>rd</sup> locating holes.

*On 5*  
 When fitting bkt next to light cover move position  
 of seat belt reel to center position of bkt.

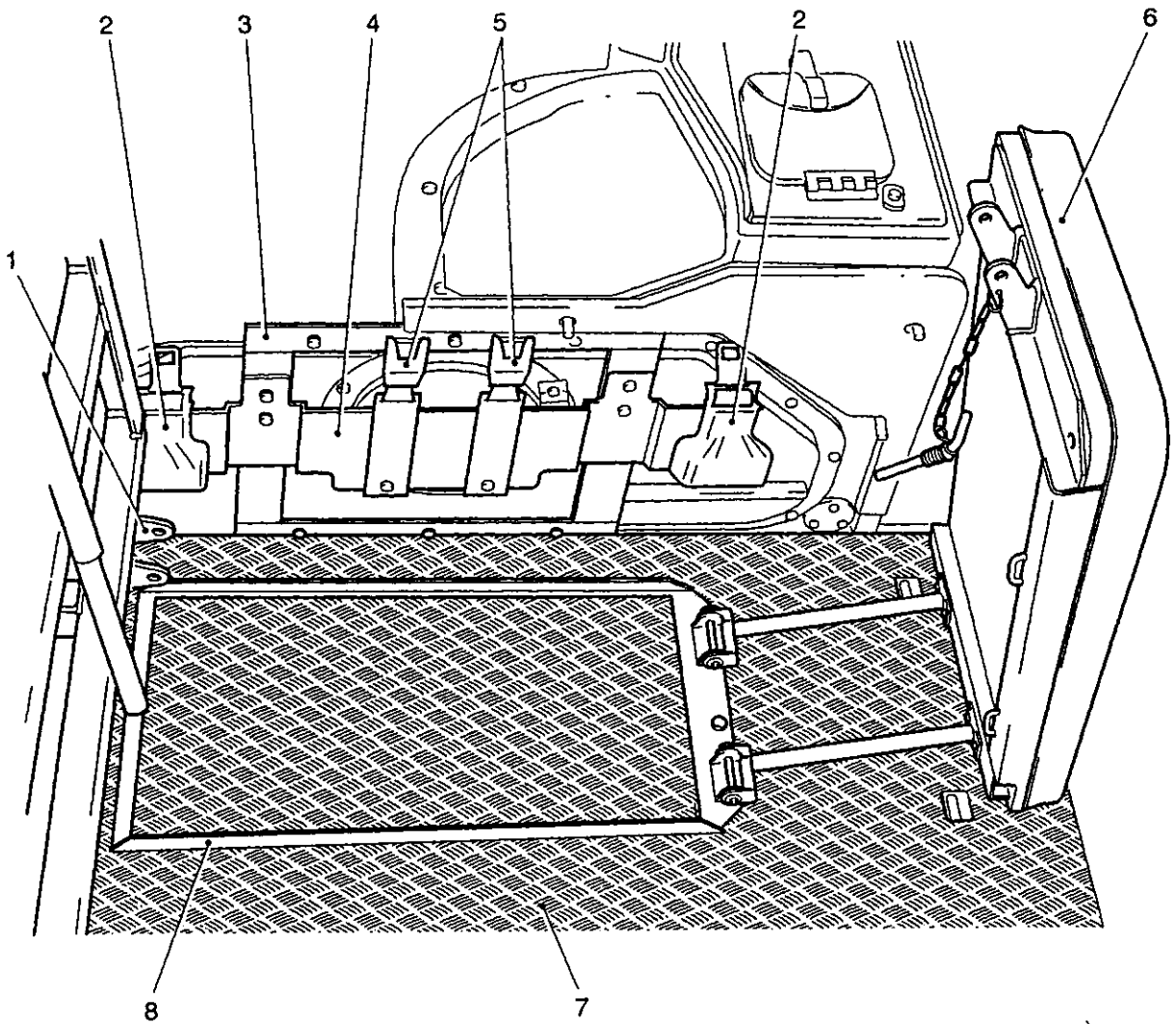

432/537

- |   |                         |   |                       |
|---|-------------------------|---|-----------------------|
| 1 | Seat attachment bracket | 5 | Seat belt stalk       |
| 2 | Seat belt reel          | 6 | Double Seat           |
| 3 | Adaptor Bracket         | 7 | Floor plate           |
| 4 | Bracket                 | 8 | Battery carrier frame |

Fig 2 Mortar variant seat belt bracket

14 Testing after embodiment – NIL.

**EFFECT ON WEIGHT**

15 Negligible.

**PUBLICATION AMENDMENTS**

16 Relevant AESP's will be amended in due course.

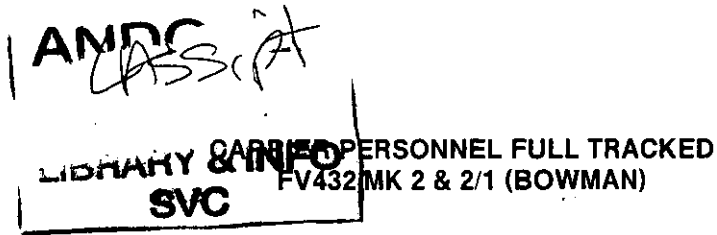

**MODIFICATION INSTRUCTION No. 6**

---

**SUSPENSION NOTICE**

**INTRODUCTION**

- 1 Implementation of this modification is hereby suspended, stores are not available.

**ACTION**

- 2 File this page immediately in front of Page 1 of Mod Instr No. 6.
- 3 Endorse, top of Page 1 of Mod Instr No. 6 with 'SUSPENDED – see Amdt No.1.

**Amendment record**

- 4 Record the incorporation of this amendment.

**CARRIER PERSONNEL FULL TRACKED  
FV432 MK 2 & 2/1 (BOWMAN)**

**MODIFICATION INSTRUCTION No. 6**

Sponsor:

DGES(L)

Publication Agency:

TES-TIG  
Task No.: 36024

**AMENDMENT RECORD**

Amdt No.	Incorporated By (Signature)	Date
1		
2		
3		

Amdt No.	Incorporated By (Signature)	Date
4		
5		
6		

**SUBJECT: Boiling vessel power harnesses**

(Approval No. 43/2/0030)

**INTRODUCTION**

1 This modification instruction details the procedure to remove the hazard created by live electrical pins on the boiling vessel (BV) power harness terminations. A new harness with a female quick release connector at the BV termination and a quick release male connector at the other end are introduced.

**APPLICABILITY**

2 This modification instruction is applicable to FV432 Mk 2 and 2/1 and FV436 Mk 2 and 2/1.

**ASSOCIATED PUBLICATIONS**

3

3.1 AESP 2350-T-251-412 Installation Instruction No. 5, Carrier Role.

3.2 AESP 2350-T-251-741 Complete Equipment Schedule, Simple.

**REASON FOR MODIFICATION**

4 Code 1 – to improve safety.

**PRIORITY**

5 Immediate.

**ESTIMATED TIME REQUIRED**

6

6.1 Embodiment: 4 man-hours.



**MODIFICATION IMPLEMENTATION PLAN**

7 This modification instruction is to be implemented by units authorized to undertake level 2 maintenance and above.

**Action required by**

8

8.1 Holding units and establishments:

8.1.1 Examine equipment documents to see if the modification is applicable and where necessary, units with level 2 maintenance support, demand the stores required.

8.1.2 On receipt of the stores, request level 2 maintenance to modify the equipment.

8.1.3 Record the modification subject and AESP details in the equipment documents.

8.2 Units authorised to complete level 2 maintenance and above:

8.2.1 When requested by users, obtain the items listed in Para 9 and carry out this instruction.

8.2.2 Record completed details of modification in vehicle documents (AB413).

8.3 All recipients of this instruction: Add particulars to AESP 2350-T-251-811 Modification Instruction Index.

**Stores, tools and equipment**

9 The following items are to be demanded quoting this instruction as authority for demand and the registration number of vehicle for equipment held by user units.

9.1 Stores to be obtained:

Item No.	DMC	NSN/Part No.	Designation	Qty per eqpt
1	6150 99 690 7261	FV2214501/1	Harness C/J to D.P.6 ✓	2
2	6150 99 988 2901	FV2214500/1	Harness	2

9.2 Stores to be discarded:

Item No.	DMC	NSN/Part No.	Designation	Qty per eqpt
3		FV582618/2	Harness	2
4		FV582617/2	Harness	2

## Sequence of operations

### NOTE

The item numbers used with Para 9 are used as reference throughout this instruction.

10 Refer to Fig 1 and embody the modification as follows:

10.1 Ensure the vehicle is parked on firm level ground with the parking brake applied and the vehicle master switch in the OFF position.

10.2 Locate the boiling vessel harness sockets on the top right hand corner of the distribution panel No. 6 Mk 1 and release existing harnesses ((item 3) qty 2) from the panel.

10.3 Release the other end of the existing harnesses ((item 3) qty 2) from the sockets on the cooker socket bracket, mounted on the rear plate, adjacent to the rear door.

10.4 Release the cable clips retaining the existing harnesses ((item 3) qty 2) and remove from the harness ((item 3) qty 2). Dispose of harnesses ((item 3) qty 2) in accordance with local procedures.

10.5 Secure new harnesses ((item 1) qty 2) to the existing cable clips and connect the 90 deg sockets to the distribution panel No. 6 Mk 1 and opposite end of the harnesses to the cooker socket bracket connectors.

10.6 Locate harnesses (item 4) qty 2)), either stowed on vehicle or in CES container (Chap 2-1-1-1 items 8 of AESP 2350-T-251-741 refers), and dispose of in accordance with local procedures.

### Testing after embodiment

11 Test as follows:

11.1 Referring to ASEP 2350-T-251-201, fit cooking vessels containing tap water in rear door stowage and connect harnesses ((item 2) qty 2) between the cooker socket bracket sockets and the boiling vessels.

11.2 Bring the water to boil, ensuring the harnesses do not overheat.

11.3 Disconnect harnesses ((item 2) qty 2) and stow as applicable (either on the vehicle or in vehicle CES container).

### EFFECT ON WEIGHT

12 Nil.

### PUBLICATION AMENDMENTS

13 Nil.

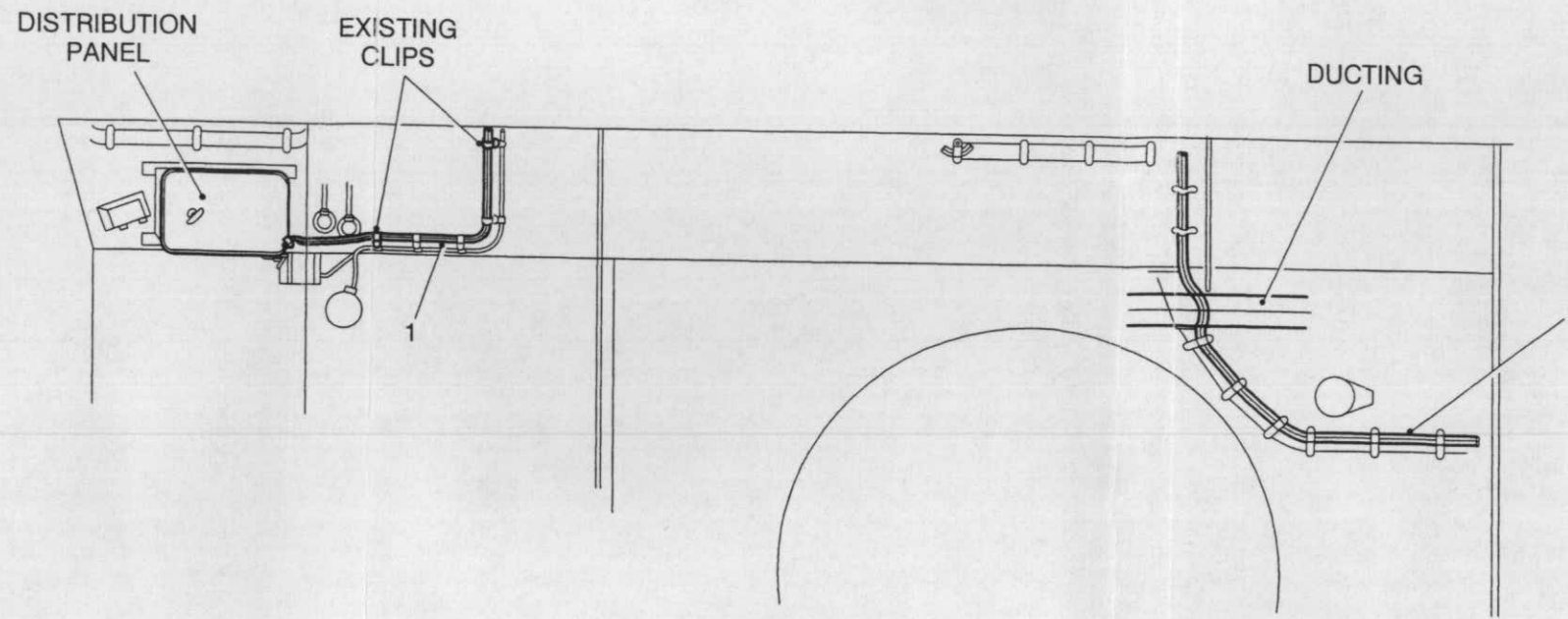

PLAN VIEW

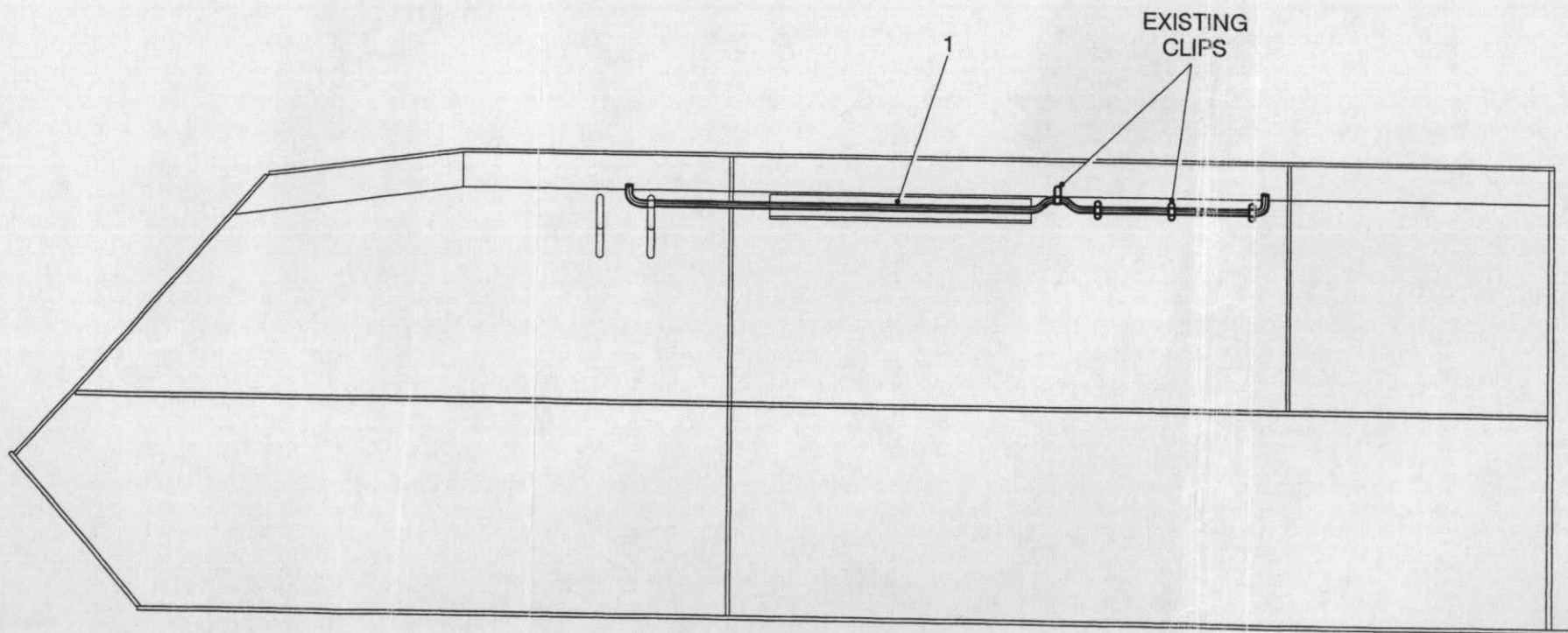
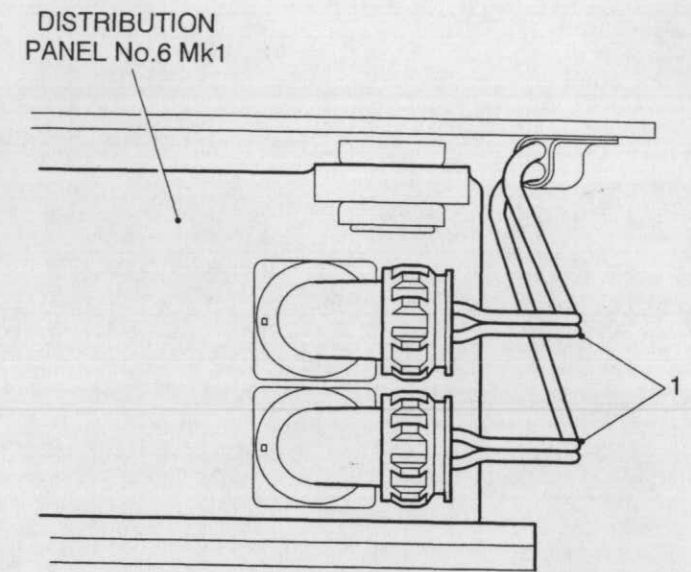

R.H. SIDE VIEW

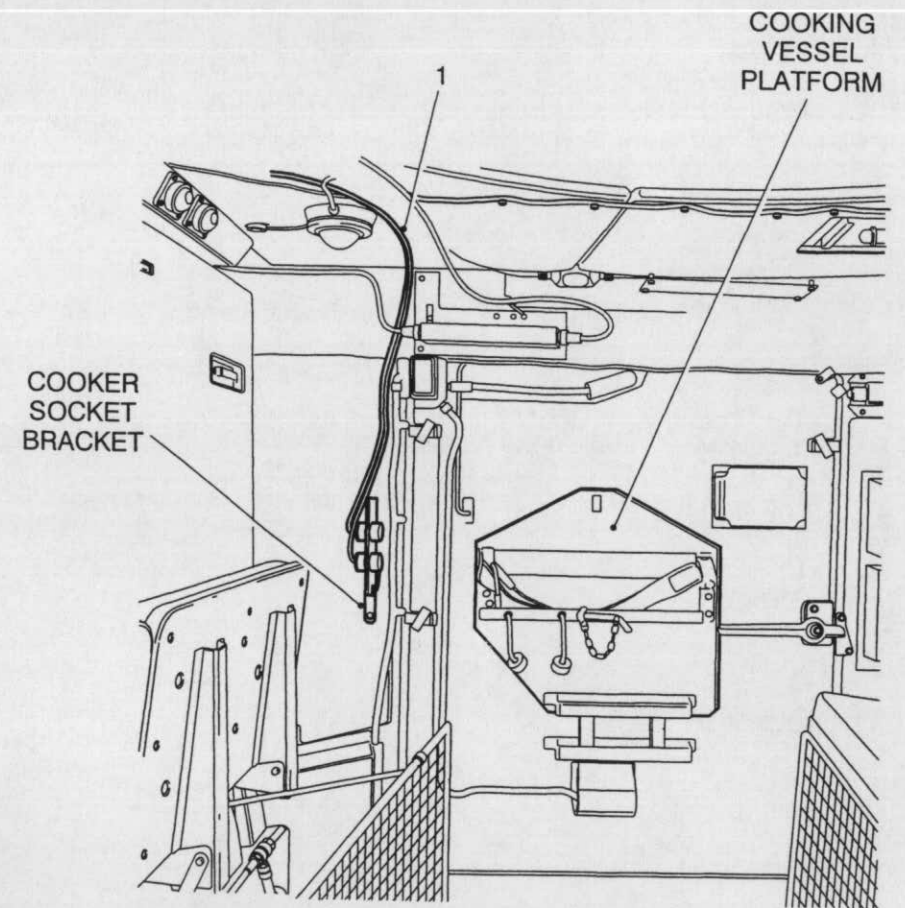

VIEW ON REAR DOOR

Fig 1 BV Harness

430/80085

**CARRIER PERSONNEL, FULL TRACKED, FV432 MK 2 AND 2/1**

**MODIFICATION INSTRUCTION No. 7**

Sponsor:  
LAS IPT

Publication Agency:  
BAE Systems Land Systems  
Task No. 36042

**AMENDMENT RECORD**

Amdt No.	Incorporated by (Signature)	Date
1		
2		
3		

Amdt No.	Incorporated by (Signature)	Date
4		
5		
6		

**SUBJECT: Hatch Locking Arm (Commander's)**

Approval No. MAE 43/2/0034

**INTRODUCTION**

1 As a result of serious equipment failure when the commander's hatch locking arm (catch) failed to lock in the open position, causing injury to personnel, a modified catch is introduced.

**APPLICABILITY**

2 This modification is applicable to: FV432 Mk 2 AND 2/1.

**REASON FOR MODIFICATION**

3 Code 1 – To improve safety.

**PRIORITY**

4 Immediate.

**ESTIMATED TIME REQUIRED**

5 Embodiment: 2 Man hours.

**MODIFICATION IMPLEMENTATION PLAN**

6 This instruction is to be implemented by units authorised to undertake level 2 maintenance and above.

**Action required by**

7

7.1 Units holding subject vehicles:

7.1.1 Demand items listed in Para 8 and carry out this instruction.

7.1.2 Record completion details in vehicle documents.

7.2 All recipients of the AESP.

Add particulars to AESP 2350-T-251-811 Modification Instruction Index.

**Stores, Tools and Equipment**

8 The item numbers given in Para 8 are used as reference throughout this instruction.

8.1 Stores to be demanded

Item No.	NSN/Part No.	Designation	Qty Per eqpt
1	2510-99-736-7835	Catch – Commander's Hatch	1
2	5315-99-944-0176	Split Pin 3/32" dia x 7/8"lg	1

8.2 Stores to be discarded

Item No.	NSN/Part No.	Designation	Qty Per eqpt
3	2510-99-865-6527	Catch – Commander's Hatch	1
4	5315-99-944-0176	Split Pin 3/32" dia x 7/8"lg	1

8.3 Stores to be removed and refitted

Item No.	NSN/Part No.	Designation	Qty Per eqpt
5	5315-99-137-8940	Pin	1
6	5360-99-865-6518	Torsion Spring	1
7	5365-99-865-6517	Distance Piece	2
8	703000800910	Plain Washer 1/2" dia x 13 SWG	2

### Sequence of operations

9 Refer to figs 1 & 2 and embody the modification as follows:

9.1 With the commander's hatch in closed position remove split pin (4) and washer (8) from one end of pin (5). Remove pin together with torsion spring (6), distance pieces (7), commander's hatch catch (3) and washer. Discard split pin and commander's hatch catch.

9.2 Refit torsion spring (6) and distance pieces (7) and fit replacement commander's hatch catch (1), securing in position with pin. Refit washer (8) and replace split pin (2).

### TESTING AFTER EMBODIMENT

10 Ensure hatch locking arm operates correctly and cannot be "bounced" out of the locked open position.

### EFFECT ON WEIGHT

11 Nil

### PUBLICATION AMENDMENTS

12 Nil.

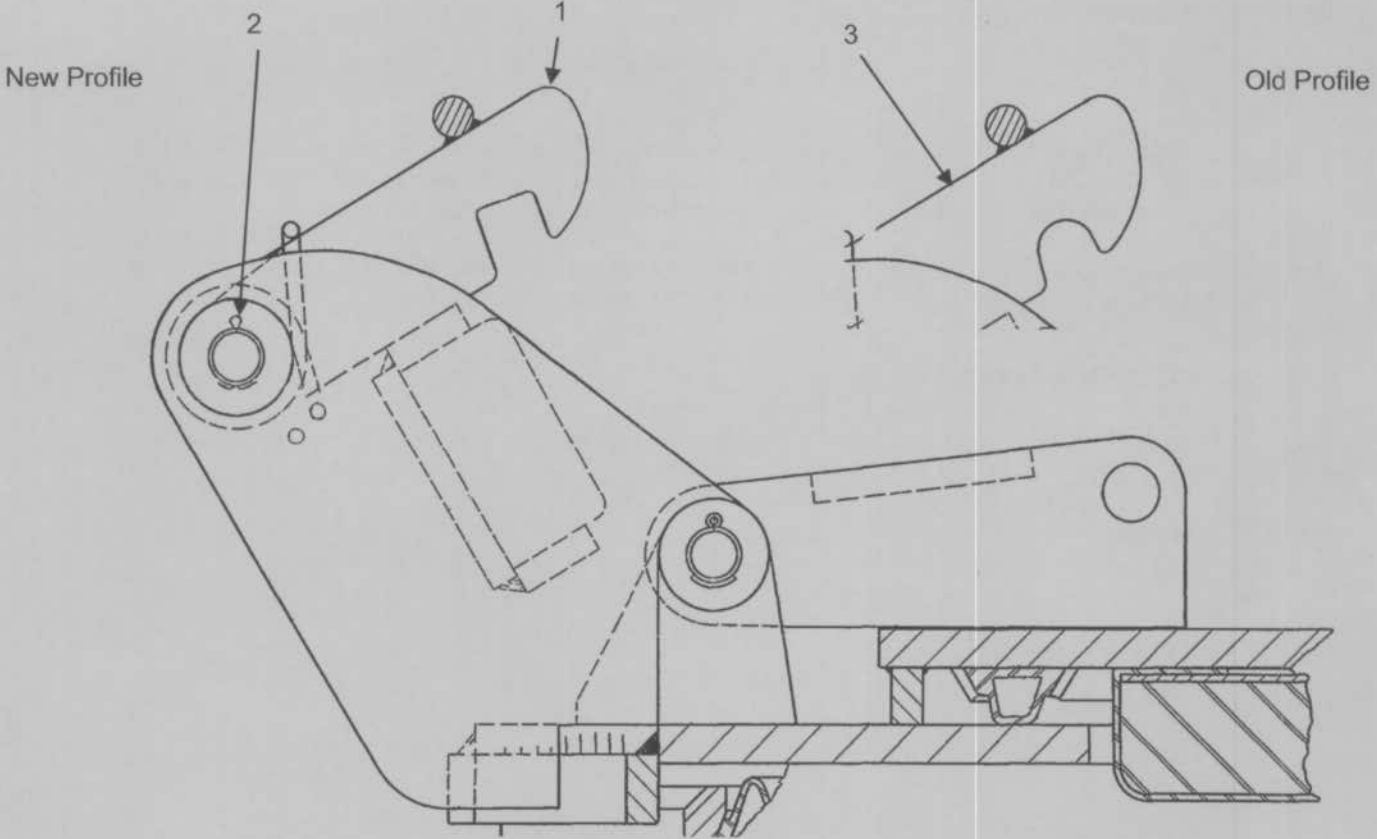

Fig 1 Catch Mechanism Side View

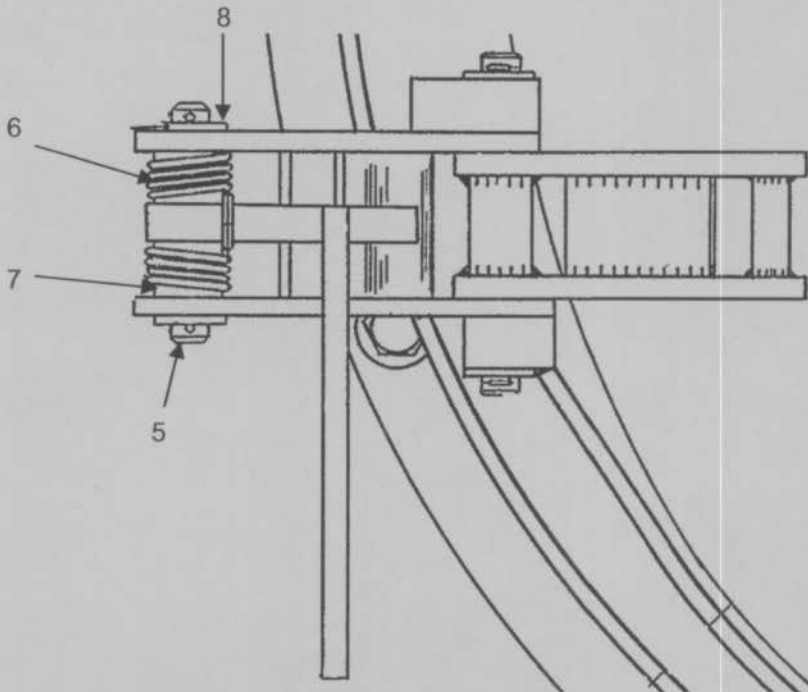

Fig 2 Catch Mechanism View from Above