



031125

CONDITIONS OF RELEASE

- 1 This information is released by the UK Government for defence purposes only.
- 2 This information must be afforded the same degree of protection as that afforded to information of an equivalent security marking originated by the recipient Government or as required by the recipient Government's security regulations.
- 3 This information may be disclosed only within the Defence Department of the recipient Government, except as otherwise authorized by the Ministry of Defence (Army).
- 4 This information may be subject to privately owned rights.

CARRIER, ARMoured STAFF VEHICLE, FULL TRACKED, MK2 AND 2/1 FV436 (ASV) (BOWMAN)

TECHNICAL DESCRIPTION

THIS DOCUMENT IS THE PROPERTY OF HER BRITANNIC MAJESTY'S GOVERNMENT, and is issued for the information of such persons only as need to know its contents in the course of their official duties. Any person finding this document should hand it in to a British forces unit or to a police station for its safe return to the MINISTRY OF DEFENCE, (DSy (Pol)), MAIN BUILDING, WHITEHALL, LONDON, SW1A 2HB, with particulars of how and where found. THE UNAUTHORIZED RETENTION OR DESTRUCTION OF THIS DOCUMENT MAY BE AN OFFENCE UNDER THE OFFICIAL SECRETS ACTS OF 1911-89. (When released to persons outside Government service, this document is issued on a personal basis and the recipient to whom it may be entrusted in confidence, within the provisions of the Official Secrets Acts 1911-89, is personally responsible for its safe custody and for seeing that its contents are disclosed only to authorized persons.)

BY COMMAND OF THE DEFENCE COUNCIL

Ministry of Defence
Issued by

DEFENCE LOGISTICS ORGANISATION

AMENDMENT RECORD

Amdt No.	Incorporated by (Signature)	Date
1		
2		
3		
4		
5		
6		
7		
8		
9		
10		
11		
12		
13		
14		
15		
16		
17		
18		
19		
20		
21		
22		
23		
24		
25		
26		
27		
28		
29		
30		
31		

Amdt No.	Incorporated by (Signature)	Date
32		
33		
34		
35		
36		
37		
38		
39		
40		
41		
42		
43		
44		
45		
46		
47		
48		
49		
50		
51		
52		
53		
54		
55		
56		
57		
58		
59		
60		
61		
62		

CONTENTS

PRELIMINARY MATERIAL

	Page
Front cover (title page).....	(i)/(ii)
Amendment record	(iii)/(iv)
CONTENTS (this list).....	(v)
PREFACE	(vi)
Introduction	(vi)
Related and Associated Publications.....	(vi)
Related Publications	(vi)
Associated Publications	(viii)
Abbreviations	(viii)
Comment on AESP.....	Final leaf

TECHNICAL DESCRIPTION

Chap

- 0 General technical information
- 1 Power pack assembly
- 2 Final drives, suspension and tracks
- 3 Hull and fittings
- 4 Ventilation control system
- 5 Electrical system

PREFACE

Sponsor: LASS IPT DLO Andover
File Ref:
Publication
Project No:

INTRODUCTION

1 Service users should forward any comments concerning this Publication through the channels prescribed in AESP 0100-P-011-013. An AESP Form 10 is provided at the end of this document, it should be photocopied and used for forwarding comments on this AESP.

2 AESPs are issued under Defence Council authority and where AESPs specify action to be taken, the AESP will of itself be sufficient authority for such action and also for the demanding of the necessary stores, subject to the provision of Para 3 below.

3 The subject matter of this publication may be affected by Defence Council Instructions (DCIs), Standard Operating Procedures (SOPs) or by local regulations. When any such instruction, order or regulation contradicts any portion of this publication it is to be taken as the overriding authority.

RELATED AND ASSOCIATED PUBLICATIONS**Related Publications**

4 The Octad for the subject equipment consists of the Publications shown. All references are prefixed with the first eight digits of this Publication. The availability of the publications can be checked by reference to the relevant Group Index (see AESP 0100-A-001-013).

5 This publication has been produced in both hard copy and microfiche formats.

Category/Sub-category		Information level				
		1 User/Operator	2 Unit Maintenance	3 Field Maintenance	4 Base Maintenance	
1	0	Purpose and Planning Information	*	*	*	*
	1	Equipment Support Policy Directives	*	*	*	*
2	0	Operating Information	201	201	201	201
	1	Aid Memoire	*	*	*	*
	2	Training Aids	*	*	*	*
3		Technical Description	201	302	302	302
4	1	Installation Instructions	*	*	*	*
	2	Preparation for Special Environments	*	*	*	*
5	1	Failure Diagnosis	*	*	*	*
	2	Maintenance Instructions	*	522	523	*
	3	Inspection Standards	*		533	*
	4	Calibration Standards	*	*	*	*
6		Maintenance Schedules (Army)	*	*	*	*
7	1	Illustrated Parts Catalogues	*	*	*	*
	2	Commercial Parts Lists	*	*	*	*
	3	Complete Equipment Schedule, Production	*	*	*	*
	4	Complete Equipment Schedule, Service Edition (Simple Equipment)	*	*	*	*
	5	Complete Equipment Schedule, Service Edition (Complex Equipment)	*	*	*	*
8	1	Modification Instructions	*	*	*	*
	2	General Instructions, Special Technical Instructions and Servicing Instructions	*	*	*	*
	3	Service Engineered Modification Instructions (RAF only)	*	*	*	*

* Categories/Sub-categories not published

Associated Publications

<u>Reference</u>	<u>Title</u>
AESP 6140-A-100-013	Secondary batteries, lead acid - Unit Care and maintenance
AESP 2300-A-100-201	Introduction to A, B and C vehicle hydraulic systems
AESP 0200-A-221-013	Painting of service equipment
AESP 0200-A-220-013	Preservation of assemblies
EMER Gen 0 331	Preparation for the repair of vehicle fuel tanks and other metal containers for flammable liquid.
EMER Pwr S 562/1	Engine, K60, No. 4, Mk 4G, Technical Handbook – Technical Description
EMER Pwr W 001	Vehicles equipped with alternators / AC generators
EMER Pwr M 106	Fuel Injection Equipment, Technical Handbook - Preferred Repair Scheme
EMER Pwr M 112/3	Fuel Injection Equipment, CAV Fuel Injector Pumps, types N and NN Technical Handbook – Technical Description
EMER Pwr M 114/3	CAV Fuel Injection Pumps, Types N and NN Technical Handbook – Field and Base Repairs
EMER Pwr M 132	Fuel Injection Equipment CAV governors and stop assemblies Technical handbook – Technical Description
EMER Pwr M 134	Fuel Injection Equipment CAV governors and stop assemblies Technical handbook – Field and Base repairs
EMER Pwr W 124/2	Rectifier unit, No 1 Mk 1, (FV342588), technical Handbook – Field and Base repairs
EMER Pwr P 154/11	Panel Distribution, No 6 Mk 1 (FV534891, Technical handbook – Field and Base repairs
EMER Pwr P 424/1	Pump, fuel pressurizing, No 2 Mk 1,(FV342593) Technical Handbook – Field and Base repairs
EMER Pwr P 454/4	Firewire control box, No 1 Mk 1, (FV494568) Technical Handbook – Field and Base repairs
EMER T & M B 021	Operators instructions for Avometer universal
EMER T & M A 028	Material Quality Assessment
EMER Wksp G 300	The cleaning, de-rusting and phosphation of iron and steel
CAV Test plan>NNL6H90/289 with hydraulic governor RHG 140	

ABBREVIATIONS

6 Throughout this Publication any reference to right or left is as seen from the rear of the vehicle looking forward, unless otherwise stated. Where non-standard abbreviations are used, the full meaning is written out in full the first time the subject is mentioned in the text, followed by the abbreviation in brackets.

CHAPTER 0
GENERAL TECHNICAL INFORMATION
CONTENTS

Para

- 1 Introduction
- 6 Engine
- Suspension and tracks
- 7 Suspension
- 8 Tracks
- Transmission
- 9 Gearbox
- 10 Steering
- Electrical equipment
- 11 System
- 12 Batteries
- 13 Fuel system
- 14 Data

Table

Page

1	Physical data	3
2	Lamps	7
3	Circuit breakers.....	7

Fig

Page

1	Overall dimensions	9/10
---	--------------------------	------

INTRODUCTION

1 This chapter contains general and technical information on the Carrier, Armoured Staff Vehicle, Full Tracked, Mk 2 and 2/1 FV 436 (ASV).

2 The Carrier, Armoured Staff Vehicle, Full Tracked, Mk 2 and 2/1 FV 436 (ASV) (Fig 1) affords covered, armoured protection for the vehicle crew, consisting of a commander and a driver and the command crew, which comprises a Staff officer and one, two or three operators, dependant on the role of the vehicle.

3 The engine, transverse gearbox and gearbox form a power pack which, with its mounting frame, may be lifted out of the vehicle. Integral are a heat exchanger, radiator, hydraulically driven automatically variable speed fans, air cleaners, oil tanks and filter. The power pack is mounted at the front of the vehicle and drives the steering unit and final drives.

4 The vehicle is equipped with an internal multi-fuel 5 kilowatt air heater as part of the Bowman fit and an external roof mounted generator, used to charge the additional radio batteries.

5 Access to the interior of the closed down vehicle is via the rear door, all hatches being locked from inside the vehicle and operable only from inside.

ENGINE

6 The engine is a K60 Mk 4F and Mk 6F, two stroke, multi-fuel, and compression ignition, vertically opposed piston type. The maximum governed speed is 3,750 rev/min while the idling speed is 800 rev/min.

SUSPENSION AND TRACKS

Suspension

7 The vehicle is supported by five torsion bar units on either side, with axle arms in the trailing position. The shock absorbers are of the friction type and are only fitted to the front and rear stations. The wheels are rubber tyred with two on each suspension unit and track adjuster.

Tracks

8 Each track consists of 90 links when new, and these are rubber bushed with rubber-padded links and are connected by hexagonal pins. The condemnation limit of the tracks is 86 links with the hydraulic ram fully extended.

TRANSMISSION

Gearbox

9 The vehicle is driven by a GM-Allison TX200-4A (or 4B) automatic gearbox having six forward gears and one reverse, with a torque converter operating in 1st, 3rd, and reverse.

Steering

10 Steering is aided by the use of a controlled differential unit.

ELECTRICAL EQUIPMENT

System

11 A 24 V negative earth system is used within the vehicle, with an ac generating system that is rectified for external battery charging.

Batteries

12 There are ten batteries fitted within the vehicle, two connected in series for automotive purposes, two fitted in series for the ventilation system, and six connected in series for the radio equipment.

FUEL SYSTEM

13 The fuel system consists of two main tanks, which are mounted in the rear of the vehicle one on either side above the track guard and a collector tank, which is located on the hull bottom plate under the rear floor. The two main tanks feed via a stop cock into the collector tank where the fuel is drawn up by an electric pump which delivers the fuel through a filter to the fuel injector. Each tank is vented through a pipe, which is connected to a vent valve mounted on the roof plate.

DATA

14 Table 1 lists the physical data relevant to the FV436 Vehicle, Mk 2 and Mk 2/1.

TABLE 1 PHYSICAL DATA

Serial (1)	Heading (2)	Detail (3)
1	Crew	Two, driver and commander
2	Personnel	Staff officer and one, two or three operators
3	Dimensions	Refer to Fig 1
4	Weights	14,706 kg (14.476 tons)
	Basic vehicle but fully fuelled	
	Weight including personal kit and CES	15,988 kg (15.738 tons)
	Total weight including Bowman equipment	16,269 kg (16.015 tons)
5	Bridge classification	17
6	Fuel	Multifuel – diesel, gas turbine, MT gasoline, premium grade motor spirit or a mixture of these fuels
7	Engine	K60 Mk 4F and 6F, two stroke, multi-fuel, compression ignition. Opposed piston type
8	Gearbox	GM-Allison TX200-4A semi-automatic gearbox having six forward gears and one reverse, with a torque converter operating in 1st, 3rd, and reverse
9	Governed speed	
	Maximum	3,750 rev/min
	Idle	800 Rev/min
10	Gears and speed	
	Gear	Speed
	1	9.8 km/h (6.1 mile/h)
	2	13.7 km/h (8.5 mile/h)
	3	19.5 km/h (12.1 mile/h)
	4	27 km/h (16.8 mile/h)
	5	37.6 km/h (23.4 mile/h)
	6	52.2 km/h (32.5 mile/h)
	Reverse	8.65 km/h (5.4 mile/h)
11	Performance	
	(permitted)	
12	Fuel consumption	
13		

(continued)

TABLE 1 PHYSICAL DATA (continued)

Serial (1)	Heading (2)	Detail (3)	
14	Range of operation	[REDACTED]	
15	Maximum gradient	35 degrees	
16	Maximum vertical obstacle	609 mm (2 ft)	
17	Minimum turning circle	5.334 m (17 ft 6 in.)	
18	Suspension		
	Type	Torsion bar, five units on each side with axle arms in the trailing position. Track adjuster at rear.	
	Wheels	609 mm (24 in.) diameter, rubber tyred. Two on each suspension unit and track adjuster	
	Shock absorber	Friction type, fitted to the front and rear stations only.	
19	Tracks		
	Links per track new)	90	
	Condemnation limit	86 (with hydraulic ram fully extended)	
20	Track guide rollers	Two for each track	
21	Steering	Lever operated controlled differential unit	
23	Smoke protection	Two forward facing multi-barrelled smoke dischargers	
24	Ammunition		
	Machine gun	Eight boxes of 200 rounds, belted for GPMG	
	Smoke discharger	Six rounds (loaded in dischargers)	
25	Vision		
	Driver	Head out for opened up position. Single wide angled AFV No. 33 Mk1 periscope	
	Commander	360-degree rotation cupola with three periscopes, both outer periscopes fixed. Centre AFV No. 32 Mk 1 periscope can be pivoted axially in vertical plane	
26	Capacities	Litres	Imperial
	Engine lubrication system	33	58 pints
	Gearbox (modified)	16.5	29 pints
	Engine governor	1.15	2 pints
	Coolant system	44.3	78 pints
	Hydraulic fan drive	22.4	39 pints
	Steering unit	26.7	47 pints
	Final drives (each)	4.3	7.5 pints
	Road and track adjuster wheels (each)	1.7	3 pints

(continued)

TABLE 1 PHYSICAL DATA (continued)

Serial (1)	Heading (2)	Detail (3)
27	Electrical equipment System	24V negative earth with AC generating system rectified for battery charging and general purposes
27.1	Batteries Number off Voltage Capacity	No. 4 Mk 3 - FV546133 10 (Para 12 refers) 12V 100Ah
27.2	Alternators Main output Cutting in speed Rotation Phase rotation Field resistance Number of poles Drive ratio (gearbox) Input torque Input HP Cooling Bearing lubrication Weight Gear teeth	2 off 0.5 kVA, 3 phase, 0.95 Power factor, 25V, line current 81 amps within the speed range of 1,750 to 1,2600 rev min (87.5 to 630 cycles sec) 1,250 rev min alternator speed Reversible A B C looking on the drive and with alternator rotating counter clockwise 0.34 ohms to 0.37 ohms at 20°C (68°F) 6 2.95:1 30.5 Nm - (22.5 lb ft (max)) 6.37 Engine oil Oil bled of main supply 500 cc per minute at 122°C(251°F) 31.3 kg (69 lb) 22
27.3	Control panel, alternator Type Voltage control Current limiting Field over heat	2 off No.1 Mk 1 - FV342587 static voltage regulator, silicon controlled rectifier Normal 28.5V ± 2% 30A max field current Alternator output reduced when field temperature exceeds 250°C (122°F)
27.4	Rectifier unit Type Input Output Frequency range Cooling Oil temperature Minimum depth of oil Fuse Ammeter shunt Weight	No. 1 Mk 1 - FV342588 6 half phase bridge rectifier 165A, 22V, 3 phase 200A, 28,5V dc 87.5 to 630 cycle sec Engine oil 122 deg C (max) Oil level to be 13 mm (0.5 in.) above any inlet hole at any angle of tilt 250A 300A, 75mV 13.8 kg (30.5 lb)

(continued)

TABLE 1 PHYSICAL DATA (continued)

Serial (1)	Heading (2)	Detail (3)
27.5	Distribution link box Type Relay No.1 (Radio battery) Type Rating Coil resistance Pull in voltage Relay No. 2 (Alternator only load relay) Type Coil resistance Pull in voltage	No. 1 Mk 1 - FV494570 CAV BBNG Continuous 28.5 to 31.5 ohms at 20 deg C (68 deg F) 16V (min) CAV L6 64 to 70 ohms 6V to 8V
27.6	Starter Type Rotation Brake HP Torque	No. 3 Mk 1 - FV546101 Clockwise viewing DE 11.5 (max) at 14V 54.24 Nm (40 lb ft at max BHP) 149.2 Nm (110 lb ft stall (2,250A, 10V approx))
27.7	Distribution panel Type Relays (4 off) Pull in voltage Drop out voltage Coil resistance	No. 6 Mk 1 - FV534891 Plessey 7CZ-106198 15V to 18V 12V (max) 165 ohms \pm 5% at 20°C (68°F)
27.8	Relay (generator only load) Pull in voltage Drop out voltage Coil resistance	Hendry D4485 15V to 18V 12V (max) 123 ohms \pm 5% at 20°C (68°F)
27.9	Radio distribution box Type Relay Pull in voltage Drop out voltage Coil resistance	No. 1 Mk 3 - FV534890 Plessey 7CZ-106198 15V to 18V 12V (max) 165 ohms \pm 5% at 20°C (68°F)
27.10	Ventilation fan motor Type Rating Output	No 8 Mk 1 FV481818 Continuous 0.27 HP at 4500 rev/min (max.), 24V with zero external resistance (17 amps max.)

(continued)

TABLE 1 PHYSICAL DATA (continued)

Serial (1)	Heading (2)	Detail (3)
27.11	Fuel pump Type Rotation Current Fuel pressure Fuel flow Operating temperature Weight	No. 2 Mk 1 - FV342593 Clockwise viewing pump end 4.5A (max) 1.7 bar (25 lb sq in) 136.4 ltr (30 gallon) per hour -40 deg C to 105°C (221°F) 5.5 kg (12 lb)
27.12	Fan controller Type Resistance, total	No 1 Mk 2 FV3422536 28 ohms

15 Table 2 details the lamps fitted to the FV436 Vehicle, Mk 2 and Mk 2/1.

TABLE 2 LAMPS

Light (1)	Volts (2)	Watts (3)	Type (4)
Tail/stop	28	30/7	SBC index pins
Side, Registration plate, Convoy, interior, locker and bulkhead	26	6	SCC
Warning and instrument panel	28	0.04	Midget flange
IR	26	100	European cap
Turn and fire warning	24	24	SCC

16 Table 3 details the rating and location of the circuit breakers fitted to the FV436 Vehicle, Mk 2 and Mk 2/1.

TABLE 3 CIRCUIT BREAKERS

Circuits (1)	Circuit Breaker		
	Location (2)	Identification (3)	Type and rating (4)
Circuit controlled by fuses F1, F3 and F5 in auxiliary junction box and smoke dischargers.	Distribution panel No. 6 Mk 1	A	15 A
Horn, 12 point socket, Lights: head, side, tail, convoy, registration plate, turn stop, IR driving.		B	15 A

(continued)

TABLE 3 CIRCUIT BREAKERS (continued)

Circuits (1)	Circuit Breaker		
	Location (2)	Identification (3)	Type and rating (4)
Fire alarm warning lights.		C	10 A
Distribution panel inspection light sockets.		D	10 A
		E (Not fixed)	
External lighting sockets.		F	25 A
Ventilating fan motor relay.		G	5 A
Heater unit.		H	35 A
Fire alarm.		J	15 A
Circuits controlled by engine switch, instrument panel light fuse and DC supply to alternator field circuits.		K	15 A
Fuel pump, injection pump stop solenoid, battery analogue.		L	15 A
Engine coolant thermometer, fuel gauge, gearbox oil thermometer, oil pressure switch, alternator (GEN) warning light, starter switch, alternator boost and instrument panel lights fuse.		M	10 A

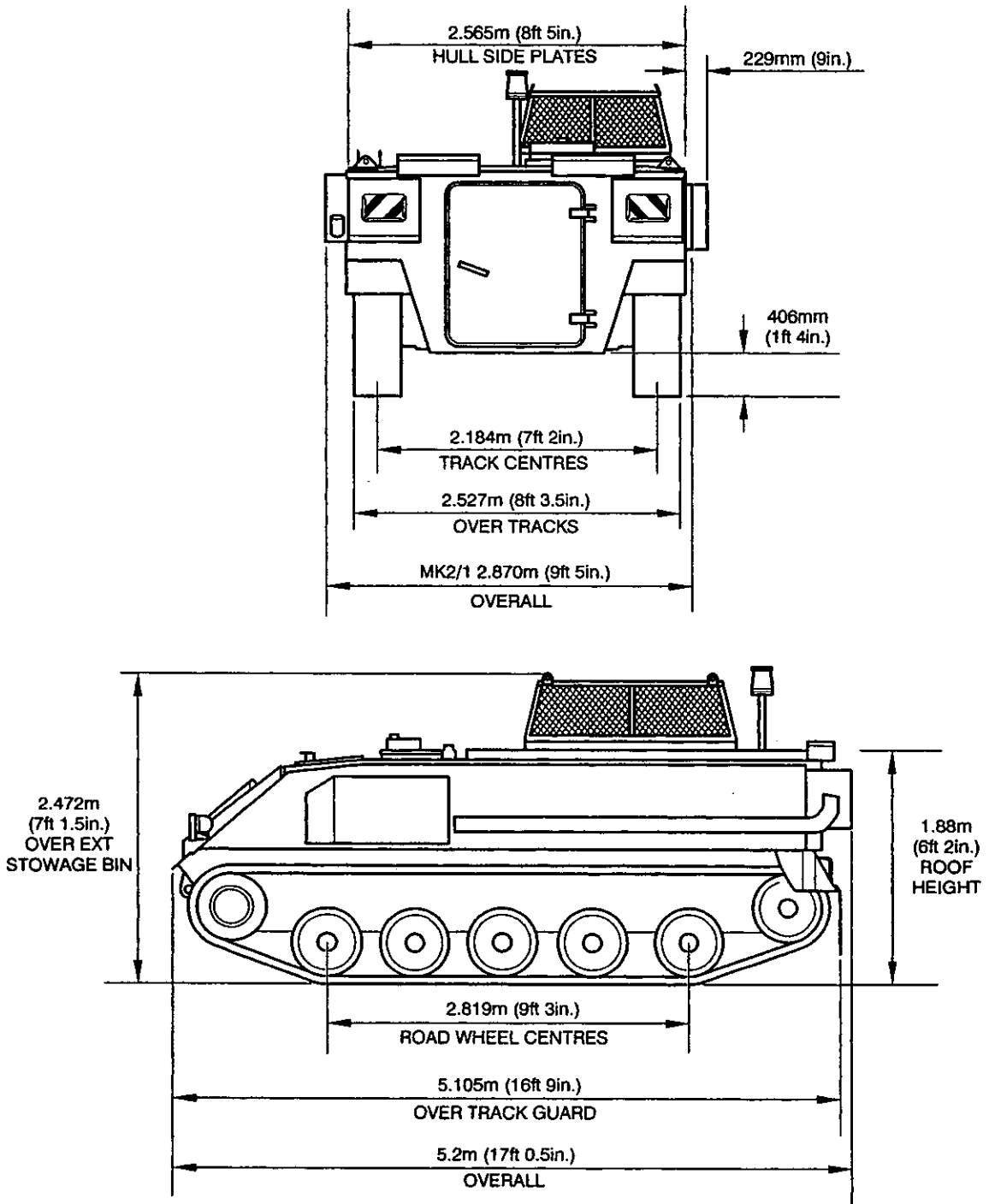

430/20095

Fig 1 Overall dimensions

CHAPTER 1-0
POWER PACK ASSEMBLY – LIST OF CHAPTERS
CONTENTS

Para

- 1 List of chapters (this chapter)

LIST OF CHAPTERS

- 1 This chapter is further sub-divided as follows:

Chap

- 1-1 Power pack
- 1-2 Engine
- 1-3 Fuel system
- 1-4 Cooling system
- 1-5 Transmission

CHAPTER 1-1
POWER PACK
CONTENTS

Para

- 1 Layout of power pack

Fig

Page

1	Power pack (rear LH view).....	2
2	Power pack (front RH view).....	3
3	Power pack (top view).....	4

LAYOUT OF POWER PACK

1 The power pack (Figs 1 to 3) is a self contained unit, which can be removed from, or installed in, the vehicle as a single assembly. It comprises an engine with its attendant oil tank (refer to Chap 1-2), heat exchanger (refer to Chap 1-4), radiator (Fig 3 (8)), hydraulic fan assembly (refer to Chap 1-4) and air cleaner (refer to Chap 1-4), with also a semi-automatic gearbox and a transfer gearbox. (refer to Chap 1-5).

2 The connection for the electrical circuits and fuel lines and couplings for the steering unit oil pipes to the heat exchanger, and the fire extinguisher discharge tubes are located at the front of the power pack.

3 The components are mounted in a frame and superstructure fabricated of box section, channel and angle iron. The engine is located on the left with the engine coupling toward the rear. The transfer gearbox is bolted to the flywheel housing and to the input end of the semi-automatic gearbox, which is mounted alongside the engine, so bringing the drive toward the front of the vehicle. A double universal jointed propeller shaft to the steering unit connects the output flange of the gearbox. The engine oil tank is positioned in front of the gearbox and secured to the frame by tie rods.

4 Mounted at the top of the superstructure towards the front is the radiator, inclined forward to suit the sloping air intake louvre in the compartment roof. To the rear of the radiator at the top of the superstructure are mounted two fans in a dished cowl, which fits under the air outlet louvre.

5 The open ends of the engine exhaust manifolds are towards the front of the vehicle. The exhaust pipes from the manifolds are connected to each other by a sliding joint, which connects to an elbow assembly through the vehicle left side plate. The expansion joint is connected at each end by an adjustable quick-release pipe clamp.

6 The hydraulic pump, which provides the power for the fan drive, is mounted at the rear of the engine and coupled to the upper crankshaft.

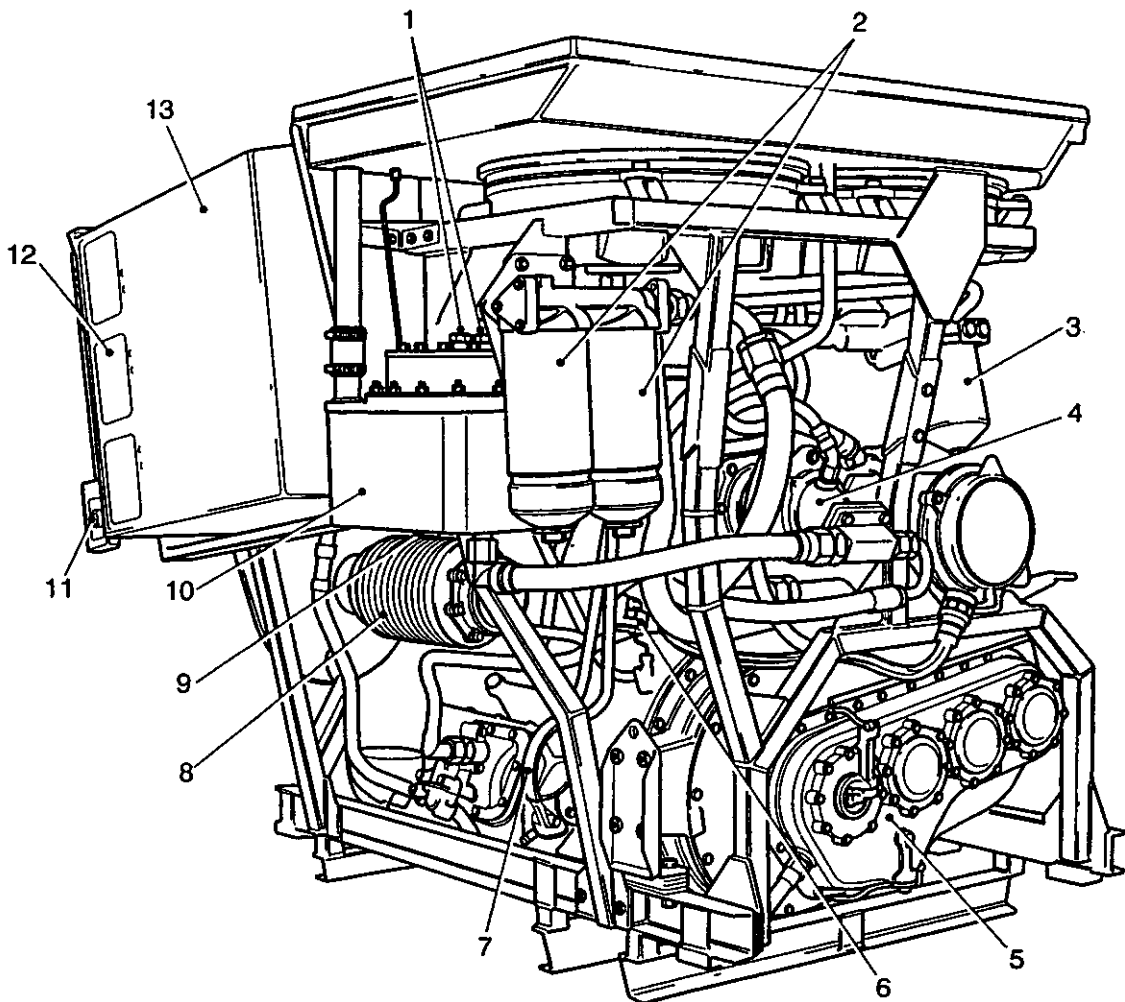

432/149

- | | | | |
|---|---------------------|----|------------------------------|
| 1 | Magnetic filters | 7 | Starter motor securing strap |
| 2 | Engine oil filter | 8 | Blower |
| 3 | Fuel filter | 9 | Hydraulic tank drain plug |
| 4 | Hydraulic fan pump | 10 | Hydraulic fans oil tank |
| 5 | Transfer gearbox | 11 | Fire wire |
| 6 | Dis-connector shaft | 12 | Air cleaner, first stage |
| | | 13 | Air cleaner, second stage |

Fig 1 Power pack, rear LH view

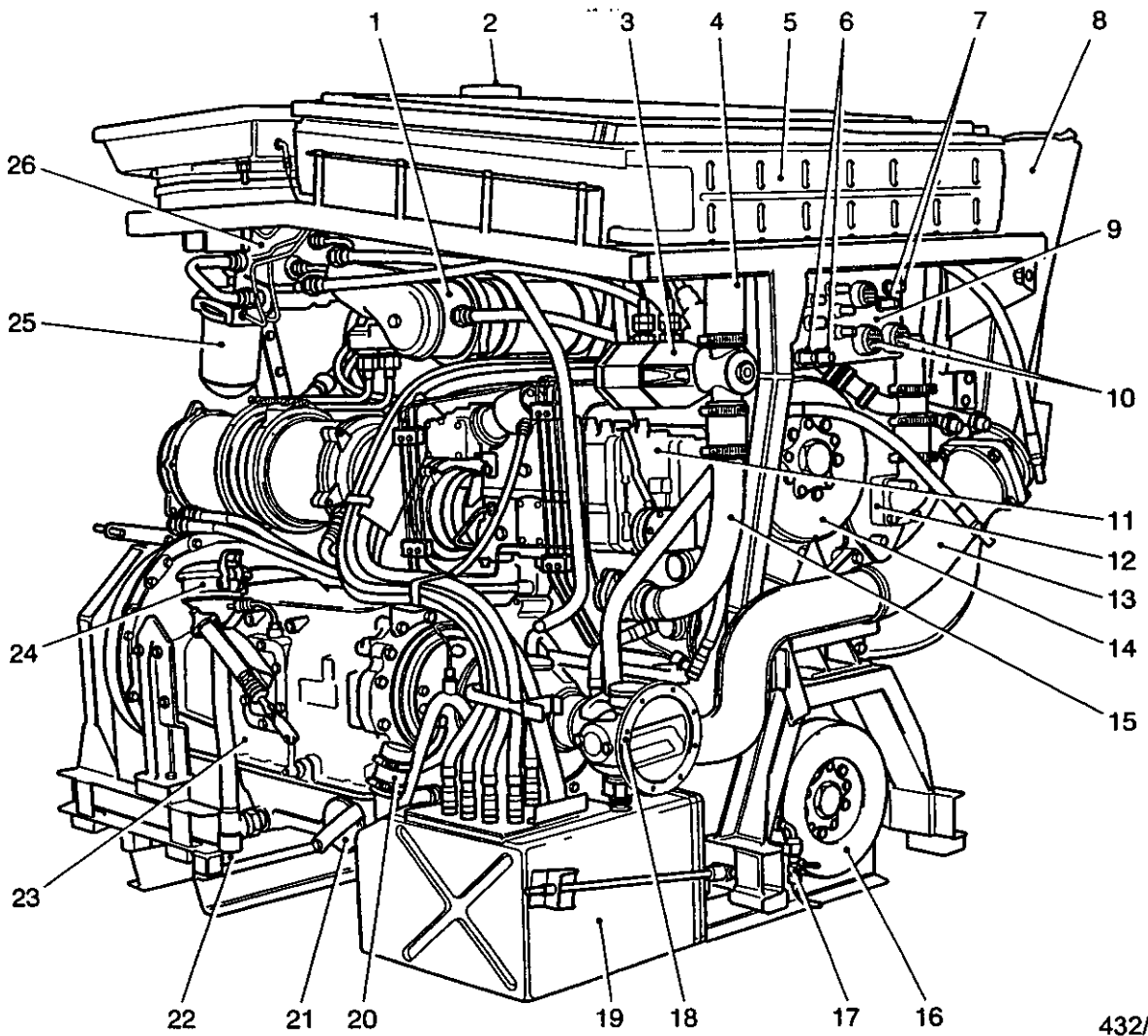

432/227

- | | | | |
|----|----------------------------|----|-------------------------|
| 1 | Heat exchanger | 14 | Upper crankshaft damper |
| 2 | Radiator filler cap | 15 | Coolant outlet hose |
| 3 | Fan controller | 16 | Lower crankshaft damper |
| 4 | Radiator coolant inlet | 17 | Coolant drain cock |
| 5 | Radiator | 18 | Prop shaft coupling |
| 6 | Fuel connectors | 19 | Engine oil tank |
| 7 | Firewire connectors | 20 | Engine oil tank filler |
| 8 | Air cleaner | 21 | Gearbox filter cover |
| 9 | Junction panel | 22 | Gearbox drain plug |
| 10 | Alternator connector plug | 23 | Gearbox |
| 11 | Ignition pump and governor | 24 | Gearbox oil filler |
| 12 | Coolant pipe | 25 | Fuel filter |
| 13 | Exhaust pipe | 26 | Fan motor |

Fig 2 Power pack, front RH view

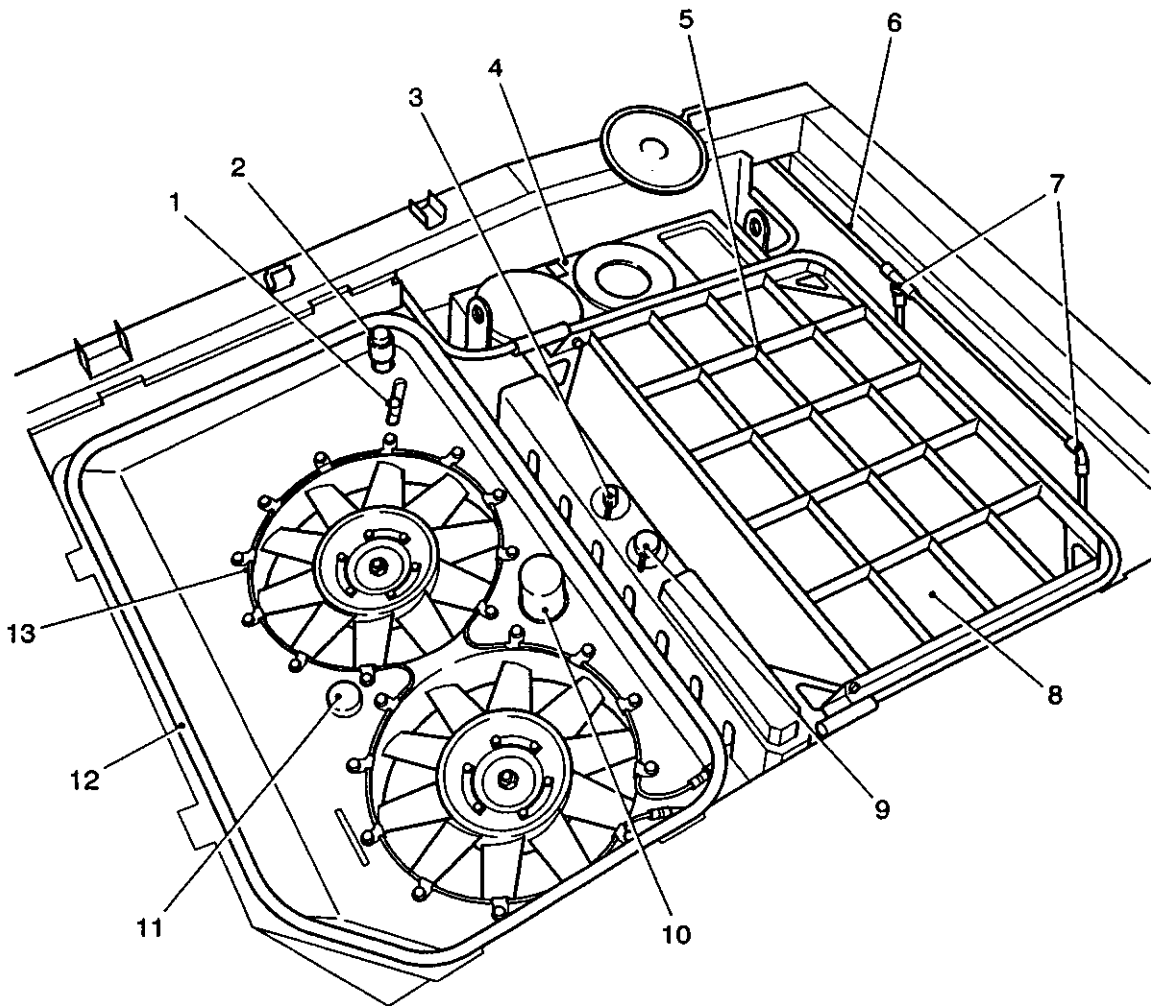

432/228

- | | | | |
|---|------------------------|----|---------------------------|
| 1 | Restrictor indicator | 8 | Radiator |
| 2 | Hydraulic tank filler | 9 | Radiator header tank vent |
| 3 | Radiator filler | 10 | Engine oil tank breather |
| 4 | Air cleaner | 11 | Engine breather (rear) |
| 5 | Support frame | 12 | Sealing strip |
| 6 | Fire extinguisher pipe | 13 | Firewire |
| 7 | Flexible hose | | |

Fig 3 Power pack, top view

CHAPTER 1-2

ENGINE

CONTENTS

Para

- 1 General
- 9 Engine lubrication system
- 12 Engine oil tank
- 16 Oil filters
- 20 Exhaust system

Fig

Page

1	Engine oil and gearbox oil tank connections	3
2	Oil tank	4
3	Engine oil filter	5
4	Exhaust system	6

GENERAL

1 Power unit for Mk 2 and 2/1 vehicle is a Rolls Royce, K60, No. 4, Mk 4F and 6F. Field repairs to this engine are detailed in AESP 2350-T-251-523.

2 UNF screw threads are used throughout on the K60 engine. Some metric threads are used on the fuel injection equipment.

3 When any external pipes are disconnected, blanking plugs or caps must be fitted to unions or open ends. If plugs/caps are not available, tape adhesive fabric should be used. Drip trays should be placed underneath power pack or engine when oil pipes are disconnected. Dimensions of oil pipe unions measured across flats are 15/16 in., 1 5/16 in., 1 5/8 in., 1 11/16 in.

4 If any sub-assembly or component is removed to expose an open part of the engine, normal precautions regarding covering and protecting must be observed. In the case of the K60 engine, if the air cleaner or scavenge blower assembly is removed it is essential that a blanking plate or cover be used over open apertures. Similarly, if an exhaust manifold is removed, ensure ports are blocked off to prevent entry of foreign material.

5 A new type of sealing arrangement is employed on some flange faces of certain components fitted to the K60 engine, and consists of sealing compound with a silk thread laid around face joint.

6 The engine flywheel and Metalastik coupling must be removed from a new or reconditioned engine in order to fit the flywheel housing (mechanical drive casing) to the engine wheel case. For details or refitting coupling and flywheel see (AESP 2350-T-251-522 Chap 1-2)

7 There are two scavenge and one pressure pump fitted, all being gear driven off the lower crankshaft, and housed inside the engine casing. Removing and dismantling oil pumps is not to be carried out at field level.

8 The scavenge blower assembly is driven from the upper crankshaft via an intermediate gear. The drive shaft extends through the centre of the top rotor and is spur gear connected at its front end (in relation to the engine) to the bottom rotor. The rotors are of a three lobed involute format, dynamically balanced on double ball and single roller bearings. A flexible coupling located by woodruff key to the gear end of the drive shaft provides drive to the engine coolant pump. Lubrication for the assembly is by pressure feed from the engine oil gallery. A small scavenge pump driven by a dog coupling from the geared end of the lower rotor shaft returns oil through a hollow dowel to the wheel case.

ENGINE LUBRICATION SYSTEM.

9 The lubrication system is based upon the dry sump principal, and consists essentially of an oil tank (Fig 1(7)) situated on the right side of the engine at the free end; an oil pressure pump and two scavenge pumps driven from the lower exhaust crankshaft and the twin full flow filters.

10 Oil is drawn from the supply tank by the pressure pump and then passed via a 4.8 bar (70 lbf in.²) relief valve and the twin filters to the oil galleries and oil holes to effect engine lubrication. Oil then drains to the bottom cover from where it is positioned at the primary driving end of the engine and the other at the free end.

11 A bleed off between the oil pressure pump and filters delivers oil to the alternators for cooling purposes as well as lubrication. Between the pumps and the filters is a 0.7 bar (10 lbf in.²) restrictor valve which reduces the oil pressure delivery to the filters to 4.1 bar (60 lbf in.²)

Engine oil tank.

12 The engine oil supply tank (Fig 2) is mounted on the right of the engine at the front end of the power pack. The tank is divided into two sections by a partition in which is mounted a brass wire filter gauze (14). The tank has a secondary function, which is to effect the cooling of the electrical rectifier unit housed within the tank.

13 In the oil return section of the tank are located the filler tube (4) which embodies a filler cap and a dipstick marked "F" (full) and "L" (low), a connection for the oil return pipe (5) from the engine via the heat exchanger, and two breather pipe connections, one from the engine crankcase (6) and the other (7) extended by pipes and hoses to pass the hydraulic fan cowling and terminating in a removable wire wool breather assembly.

14 In the oil supply section of the tank is mounted the rectifier on the mounting plate (1) of which is a connection (3) for the supply to the engine oil pump.

15 Attached to the underside of the top of the tank, directly beneath the oil return pipe, is a spreader (8) and de-frothing tray (16) assembly, the purpose of which is to prevent the returned oil from causing frothing in the tank. The frothing is obviated by channelling the oil from under the spreader hood at the end of the return pipe, onto a sloping tray, before it cascades into the tank.

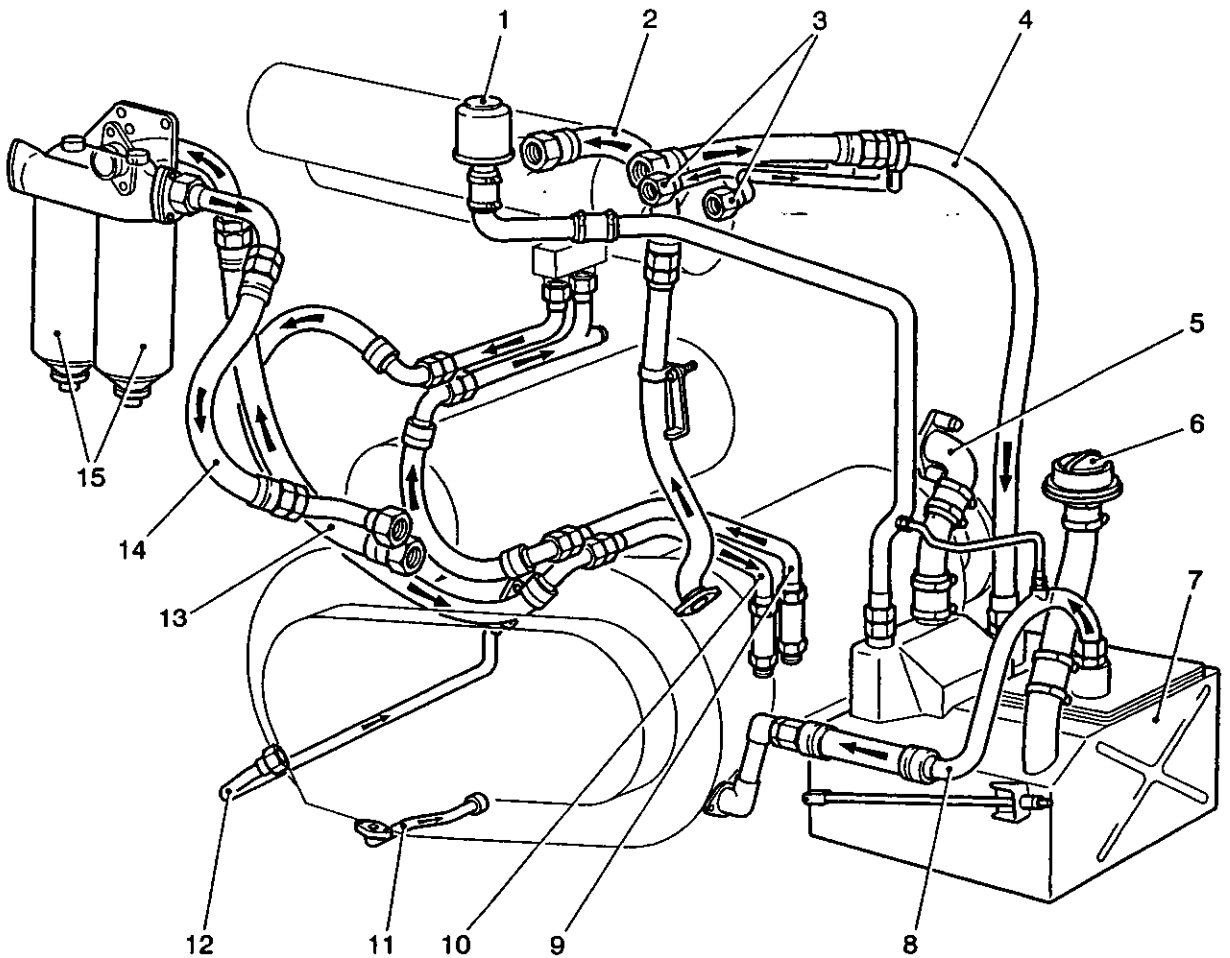

432/237

- | | | | |
|---|--|----|---|
| 1 | Oil tank breather | 9 | Gearbox to heat exchanger |
| 2 | Engine scavenge pump to heat exchanger | 10 | Heat exchanger to gearbox |
| 3 | Steering unit and steering unit oil tank to heat exchanger connections | 11 | Transfer gearbox scavenge pump return sump |
| 4 | Return to oil tank from heat exchanger | 12 | Transfer gearbox oil return, with engine disconnected |
| 5 | Crankcase breather pipe | 13 | Engine pressure pump to filters |
| 6 | Oil tank filter | 14 | Filters to engine oil gallery |
| 7 | Engine oil tank | 15 | Engine oil full flow filters |
| 8 | Tank to pressure pump | | |

Fig 1 Engine oil and gearbox oil tank connections

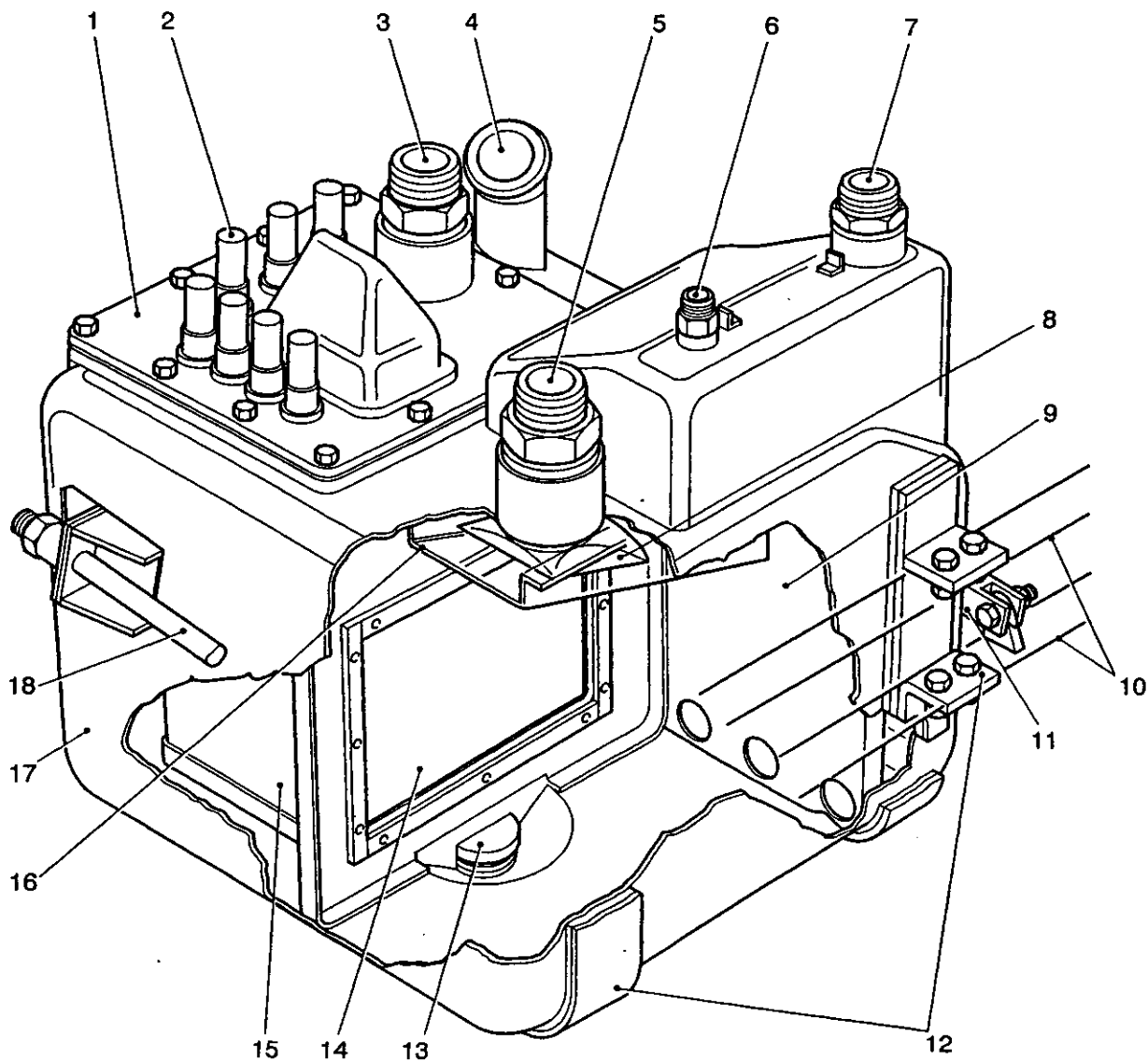

432/238

- | | | | |
|---|---|----|--------------------------|
| 1 | Rectifier mounting plate | 10 | Power pack frame |
| 2 | Rectifier connections | 11 | Tie rod |
| 3 | Oil outlet to engine pressure pump | 12 | Oil tank mounting cradle |
| 4 | Filler tube | 13 | Drain plug housing |
| 5 | Oil return connection from heat exchanger | 14 | Filter gauze |
| 6 | Engine crankcase breather connection | 15 | Rectifier unit |
| 7 | Oil tank breather connection | 16 | De-frothing tray |
| 8 | Spreader hood | 17 | Oil tank |
| 9 | Partition plate | 18 | Tie rod |

Fig 2 Oil Tank

Oil filters

16 The twin bowl, full flow oil filters (Fig 3) are vertically positioned, secured to a common header bracket bolted to the power pack frame and hydraulic oil tank, located to the left rear of the power pack.

17 The bowls (4) are retained against sealing rings (15) in the head casting by centre bolts (6), which are nut (1) and retainer (12) secured.

18 A relief valve (13) for each filter incorporated in each filter head casting is designed to allow oil to by-pass the element (5), should the element become clogged and cause a restriction to the oil flow. The relief valve operates when the pressure differential across the filter inlet and outlet passages reaches between 0.5 bar to 0.8 bar (8 lbf in² and 12 lbf in²).

19 Filtration is achieved by forcing oil the oil through expendable elements housed in the cylindrical container bowls. The elements can be either wrapped felt or cartridge type. Oil under pressure passes through the inlet port above each container to the outside of each element, percolates through to the inner formed chamber, and leaves by a central passage in the header to the outlet port.

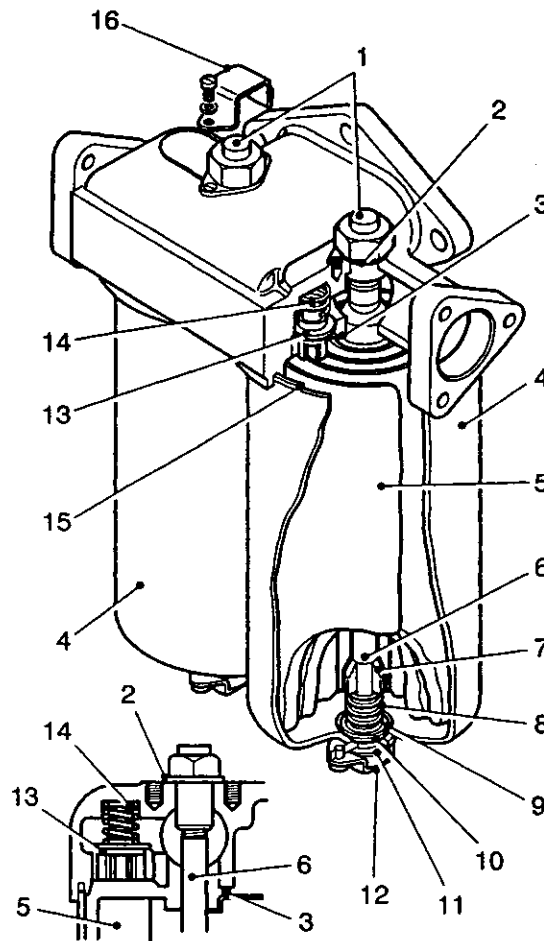

432/239

- | | | | |
|---|---------------|----|---------------------|
| 1 | Cap nut | 9 | Copper washer |
| 2 | Copper washer | 10 | Rubber washer |
| 3 | Rubber washer | 11 | Washer |
| 4 | Bowl | 12 | Bolt retainer |
| 5 | Element | 13 | By-pass valve |
| 6 | Centre bolt | 14 | Valve spring |
| 7 | Cork seal | 15 | Rubber sealing ring |
| 8 | Spring | 16 | Nut retainer |

Fig 3 Engine oil filter

EXHAUST SYSTEM

20 An adjustable quick release pipe clamp (Fig 4 (8)) connects the engine exhaust system with an armoured elbow (7) bolted through a port in the vehicle left side plate, that connects to a silencer and tail pipe (1) mounted on the left side of the vehicle, which directs the exhaust gases to the rear of the vehicle.

21 The silencer (6) has a rectangular form with an oval cross section, having an asbestos heat shield sandwiched between its outer skins, and is secured by four steel clamping straps (4) mounted in pairs, the four clamping bolts (5) also attach the silencer brackets to the welded hull side plate.

22 A pipe clamp attaches the tail pipe to the silencer, the joint is sealed by a "V" section, copper-asbestos ring (3). Two clips (2) secure the pipe to studs welded to the side plate. An extension pipe (13) with support strut (15) can be connected by pipe clamp and sealing ring, to the upturned end of the tailpipe, to enable the exhaust gases to be deflected to a higher level when the vehicle is required for a specialized role. When not in use the extension pipe is stowed in two brackets (12) and (14) positioned to the left side of the vehicle top plate. The pipe clamp used to connect extension to tail pipe also provides the extension attachment to the forward stowage bracket (14). A protector plate is bolted to the hull side plate to prevent damage to the forward silencer connection.

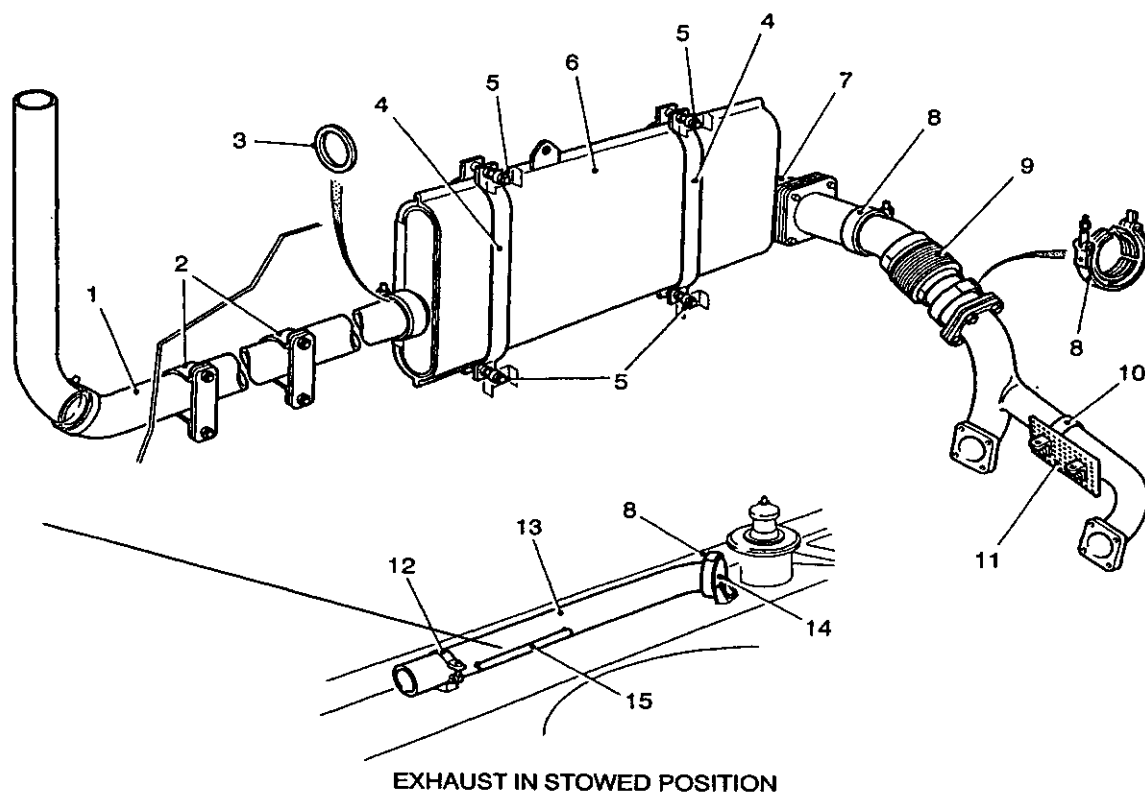

432/240

1	Tail pipe	9	Expansion joint
2	Clips	10	Sliding joint
3	Seal ring	11	Heat shield
4	Clamping straps	12	Bracket
5	Bolts and nuts	13	Extension pipe
6	Silencer	14	Bracket
7	Elbow	15	Strut
8	Pipe clamps		

Fig 4 Exhaust system

CHAPTER 1-3

FUEL SYSTEM

CONTENTS

Para

- 1 General
- 2 Main fuel tanks
- 5 Collector tank
- 11 Heater fuel supply
- 12 Fuel filter
- Engine speed and fuel cut off controls
- 15 Accelerator pedal and linkage
- 16 Hand control
- 17 Fuel stop control

Fig		Page
1	Fuel system diagrammatic	2
2	Main fuel tank.....	3
3	Fuel collector tank and cock.....	5
4	Drain valve	5
5	Fuel filter	6
6	Engine speed and fuel cut off control	8

GENERAL

1 The fuel system is shown diagrammatically in (Fig 1). The fuel tanks (5 and 9) are mounted in the rear of the vehicle, one on either side above the trackguard. The tanks feed via a stop cock (8) into a collector tank (11) under the vehicle floor from where the fuel is drawn by an electric pump which delivers the fuel through a filter (12) to the fuel injector pump (13). A pipe from the top of each tank is connected to a vent valve mounted on the roof plate.

MAIN FUEL TANKS

2 The main fuel tanks are similar but made symmetrically to the opposite hand except for the rotary position of the fuel gauge flange. The tanks are made of mild steel sheet with swaging at the ends to add strength. Swaging around the body of the tank is utilised to prevent the securing straps from moving. Internal baffles are fitted to curb surge of the fuel and at each end a hinging lifting handle is fitted. Two outlet connections are welded to the bottom of each tank, one at each end, and a connection is welded to the top of the tank for a vent pipe. Also at the top of the tank are two flanges, one for the filler and the other one for a fuel gauge. A fuel gauge is fitted to the right hand tank only, the flange on the left tank being covered by a blanking plate and joint. On the left tank, located centrally between the two outlet connections, are two connection bosses fitted with union adapters for the fuel leak-off pipes (Fig 1(10)) from the power pack.

3 The filler is protected by a hinged domed cover (Fig 2(8)) on the roof plate. The cover is retained when closed by a spring-loaded plunger engaging in a lug on the roof plate. The plunger is withdrawn by means of a hand ring (10). As the vehicle is refuelled, the fuel is initially strained by a gauze filter (25).

4 Each tank is secured in position by two straps made of galvanised cable with hexagonal and threaded end fittings. Between the hexagons the cable is covered with a PVC sleeve. A protection plate for the fuel tank is attached to the inside of the vehicle side plate by studs with felt washers, plain washers and nuts. Two loops are welded to the top of the plate, each loop holding a trunnion into which the shorter threaded end of a strap is screwed. The other end of the strap is passed through a hole in a bracket welded on the top of the trackguard and secured with a nut. Felt pads are fitted between the tank and protection plate and under the tank on top of the trackguard

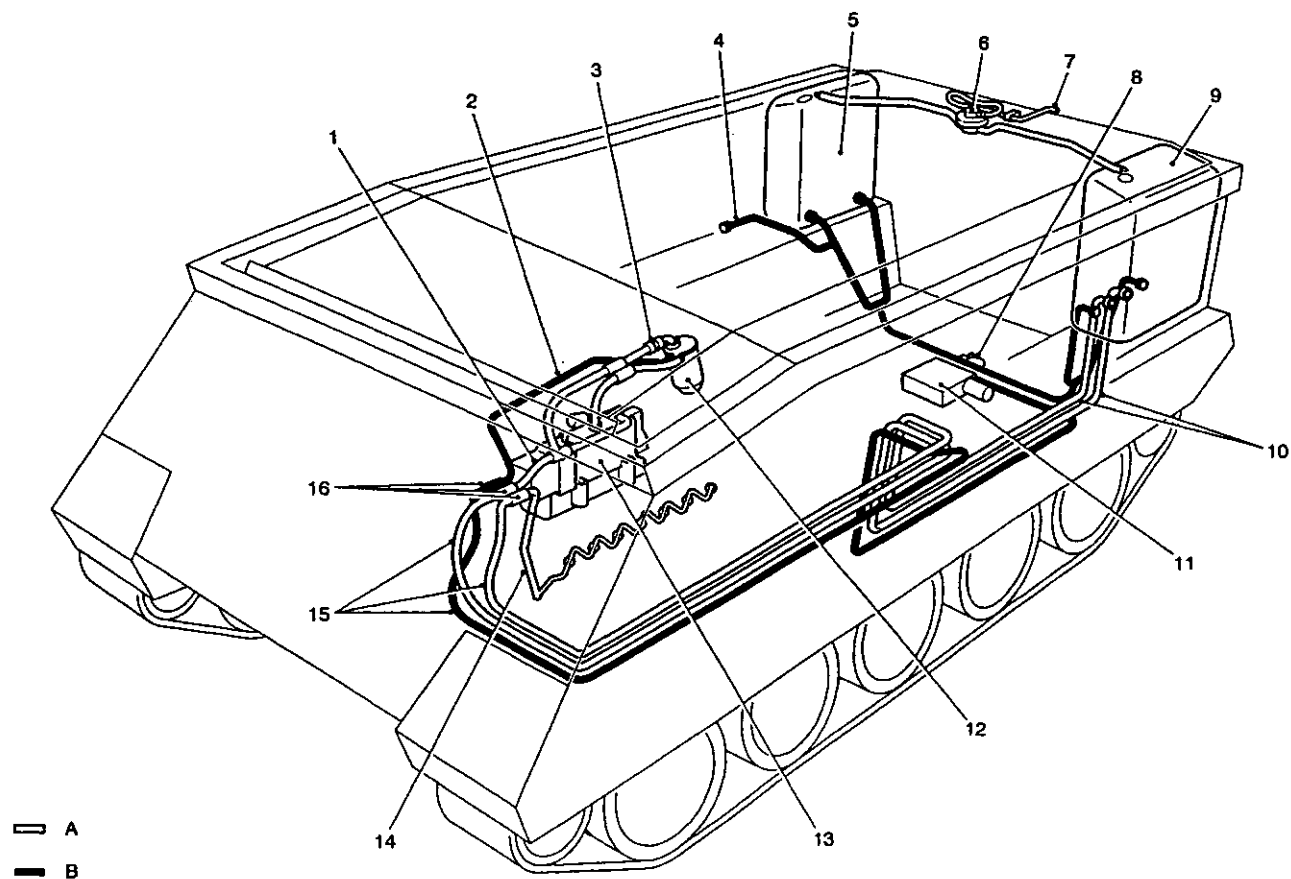

432/258

- | | | | |
|---|--------------------------------------|----|--------------------|
| 1 | Fuel injector pump and filter relief | 9 | Left tank |
| 2 | Fuel supply | 10 | Fuel return pipes |
| 3 | Relief valve | 11 | Collector tank |
| 4 | Heater connection | 12 | Filter |
| 5 | Right tank | 13 | Fuel injector pump |
| 6 | Vent valve | 14 | Nozzle leak off |
| 7 | Vent tube | 15 | Flexible hoses |
| 8 | Fuel cock | 16 | Couplings |
| A | Fuel return | B | Fuel supply |

Fig 1 Fuel system diagrammatic

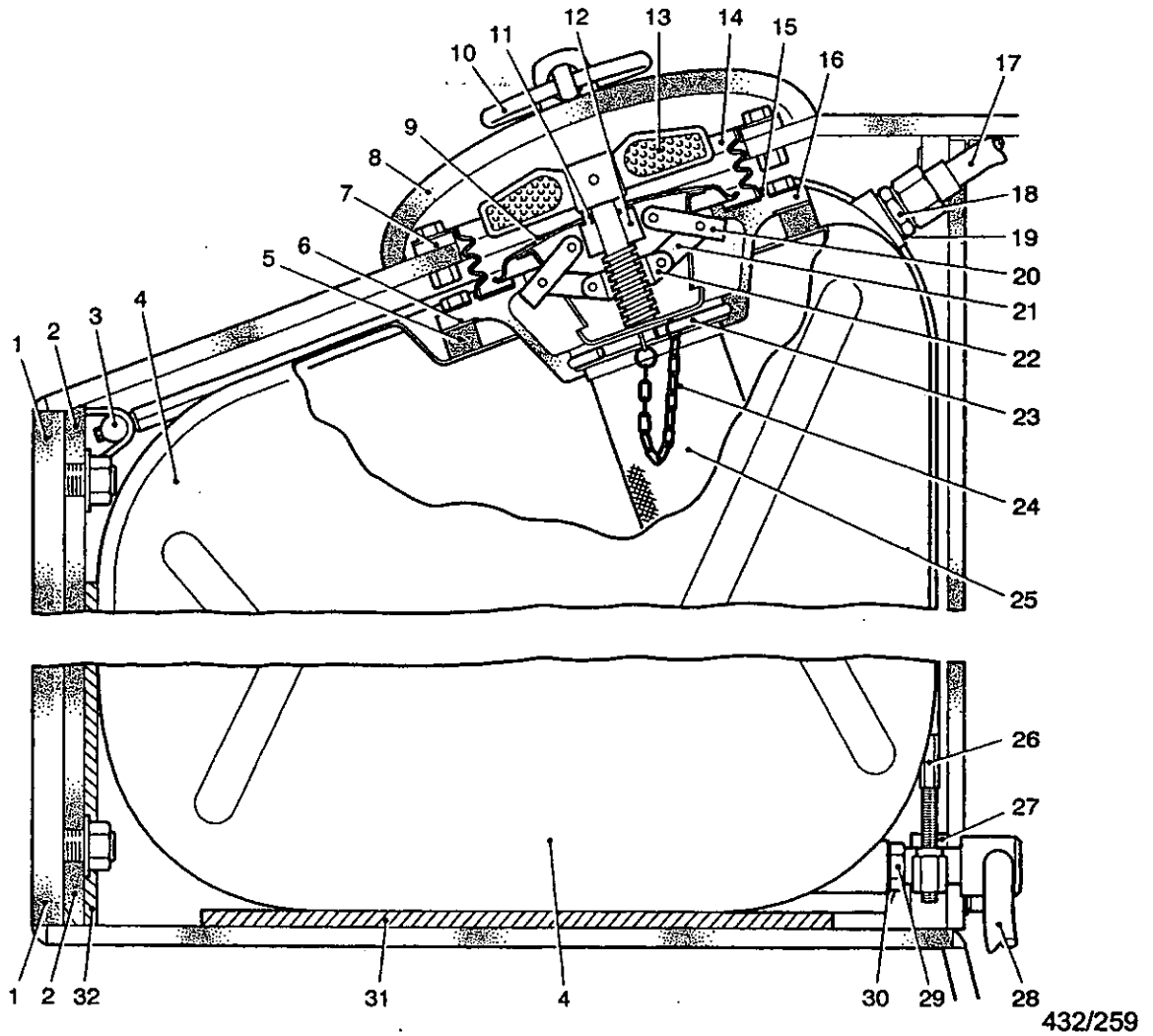

- | | | | |
|----|-----------------------|----|---------------------|
| 1 | Hull | 17 | Vent pipe |
| 2 | Protection plate | 18 | Adaptor |
| 3 | Trunnion | 19 | Sealing washer |
| 4 | Fuel tank | 20 | Locking arm |
| 5 | Flange | 21 | Link |
| 6 | Gasket | 22 | Nut |
| 7 | Sealing ring | 23 | Spring clip |
| 8 | Cover | 24 | Cap retaining chain |
| 9 | Filler cap | 25 | Gauze filter |
| 10 | Hand ring | 26 | Strap threaded end |
| 11 | Sealing ring | 27 | Bracket |
| 12 | Collar | 28 | Outlet pipe |
| 13 | Winged handle | 29 | Adaptor |
| 14 | Corrugated ring | 30 | Sealing washer |
| 15 | Neoprene sealing ring | 31 | Felt pad |
| 16 | Filler cap housing | 32 | Felt pad |

Fig 2 Main fuel tank

COLLECTOR TANK

5 The fuel collector tank (Fig 3) is located on the hull bottom plate beneath the rear section of the floor plate, access to the tank is via the cut out plate at the rear of the vehicle floor plate. The tank (2) is a rectangular box construction of mild steel plate, flange supported at the front and rear between two hull reinforcement cross members. Mounted on the tank is the fuel pump (1) and filter assembly, fuel tanks drain valve, spill valve (3) and the fuel cock assembly (7).

6 The fuel passes from the tanks via the fuel cock into the collector tank from where it is drawn through a fine wire mesh filter within the collector into the pump and then delivered to the power pack.

7 The fuel cock is a two-way plug cock type. The handle movement is restricted to a 90 deg arc between positive stops and a groove in the top of the valve plug denotes the position of the port also an indicator plate beneath the handle indicates 'OFF' or 'ON'.

8 The fuel tanks drain valve comprises a domed cover and drain valve assembly (Fig 4), the dome being bored out at the base to fit a spigot on the valve assembly. The assembly, with a joint washer, is secured to the cover with bolts and spring washers. The cover is flanged and bolts through the flange secure it to the bottom plate. The cover has, screwed into the side of it, three unions, the two larger ones connecting one with each fuel tank and the smaller one with the three-way valve. One half of the valve housing extends up into the cover and is drilled and tapped at the top for a plug, which is bored to receive the valve spindle. After assembly, the plug is secured in position by three centre punch dots around the joint line. The valve (6) is held down on its seating by a spring (5) acting between a shoulder on the valve sleeve (3) and the back of the valve. The lower part of the housing is drilled and tapped to receive two plugs, a regulating plug (9) and a shorter plug (8), the latter positioned directly under the valve. The plugs are of different length, the regulating or longer one is flanged to overlap the head of the short plug and therefore must be removed first. When the tank is to be drained, both plugs are removed and the regulating plug transferred to the hole under the valve. As the plug is screwed in, it eventually lifts the valve from its seat and the fuel drains through the other plughole. Screwing the plug in or out can regulate the flow.

9 The spill valve allows any water or sediment that may have collected in the sump recess below the feeder pipe within the tank to be expelled by the weight of the fuel. The valve comprises of a hexagon headed pin (Fig 3(5)) with a screwed body and 60 deg tapered foot. The pin is locked in position by a locknut (4).

10 The filter assembly comprises an element and adaptor, the element is passed over the adaptor tube and sealed at each end by integral sealing rings, the adaptor tube being blanked at one end and silver soldered to the adaptor block. A banjo bolt to the inlet connection of the fuel pump body attaches the block. The fuel passes through the filter element gauze thence through three holes drilled along the adaptor tube side, the holes being positioned to the top to obviate the possibility of an air lock in the tube, the ports in the banjo bolt allow the fuel to pass into the flange mounted electric fuel pump described in Chap 5.

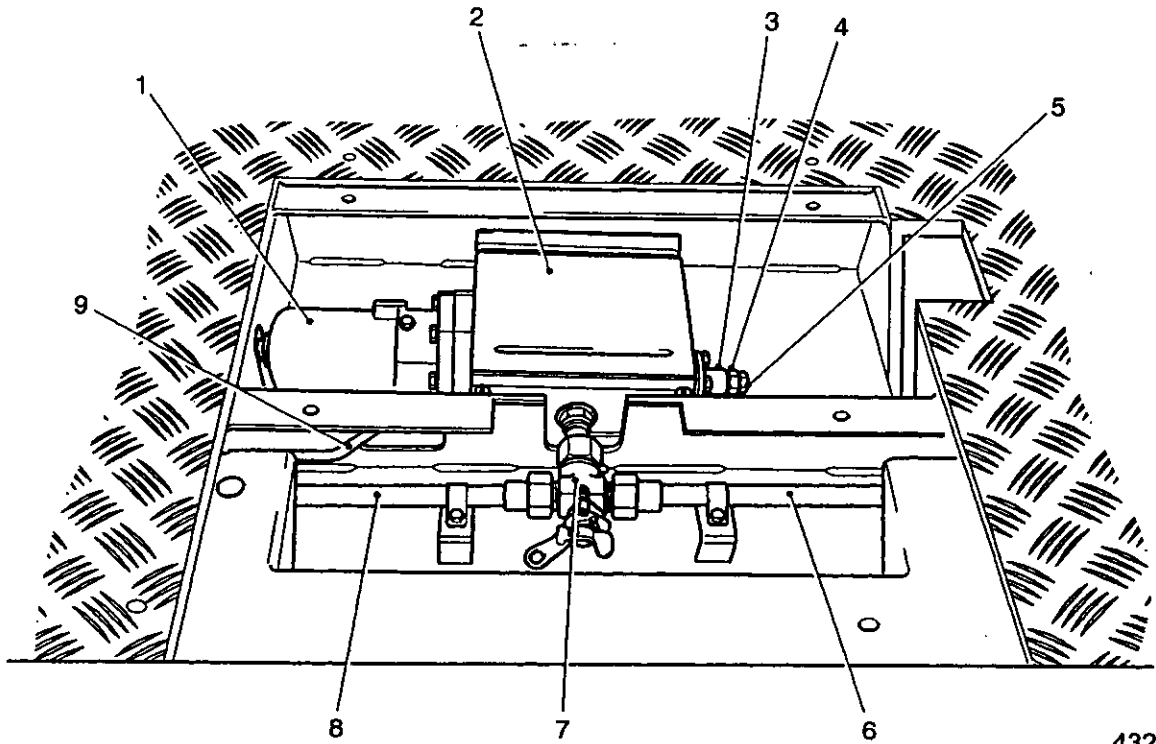

432/053a

- | | | | |
|---|----------------|----|---------------------------|
| 1 | Fuel pump | 6. | Fuel pipe from right tank |
| 2 | Collector tank | 7 | Fuel cock |
| 3 | Spill valve | 8 | Fuel pipe from left tank |
| 4 | Locknut | 9 | Fuel pipe to engine |
| 5 | Valve pin | | |

Fig 3 Fuel collector tank and cock

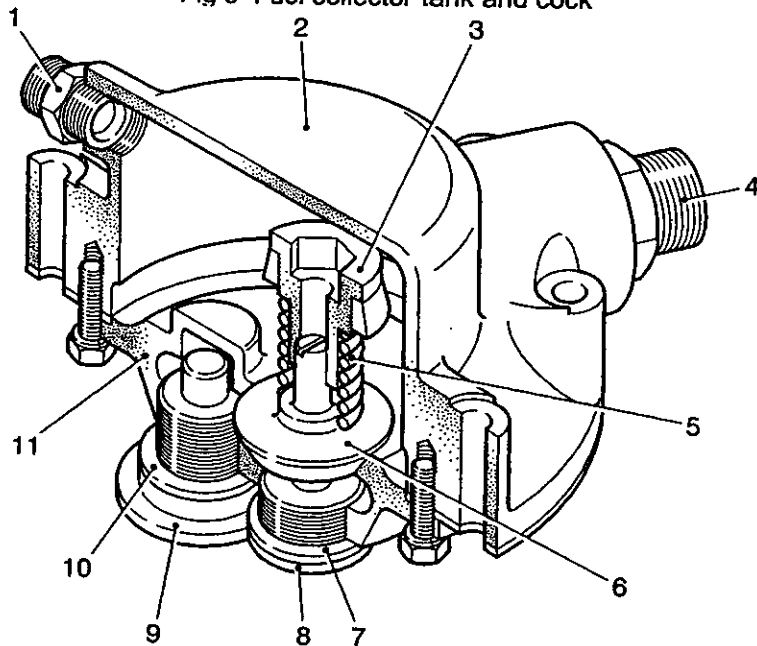

432/261

- | | | | |
|---|-------------------|----|-----------------|
| 1 | Outlet connection | 7 | Gasket |
| 2 | Casing | 8 | Short plug |
| 3 | Valve sleeve | 9 | Regulating plug |
| 4 | Inlet connection | 10 | Gasket |
| 5 | Valve spring | 11 | Valve plate |
| 6 | Valve | | |

Fig 4 Drain valve

HEATER FUEL SUPPLY

11 A connection (Fig 1(4)) is provided for a fuel supply to a multi-fuel heater. The heater is provided as a kit to be drawn and added to vehicles operating in cold climates. A support bracket is welded to the right fuel tank bulkhead. The connection secured by a nut faces the right side plate. To one side of it there is a pipe communicating with the right main fuel tank via a tee piece. The other side of the adaptor is blanked off until required, when a self sealing coupling may be added to provide the heater fuel supply.

FUEL FILTER

12 A fuel filter (Fig 5), connected in the main fuel system, is bracket mounted on the power pack frame at the right upper side of the engine. It consists of a corrugated impregnated paper element (2) contained in a detachable steel bowl (1), which is secured against a seal on the underside of the die-cast filter head (3) by a centre bolt (8).

13 The element is positioned by its seals under the influence of compression spring (15). Fuel enters by the inlet port (12) to the outside of the element and percolates through to the inner formed chamber and leaves by a central passage in the head connected to the outlet port (11).

14 A leak-off connection (10) to the pressure relief valve is located in the inlet port passage and a bleed screw (7) is provided in the outlet port passage, for venting the filter.

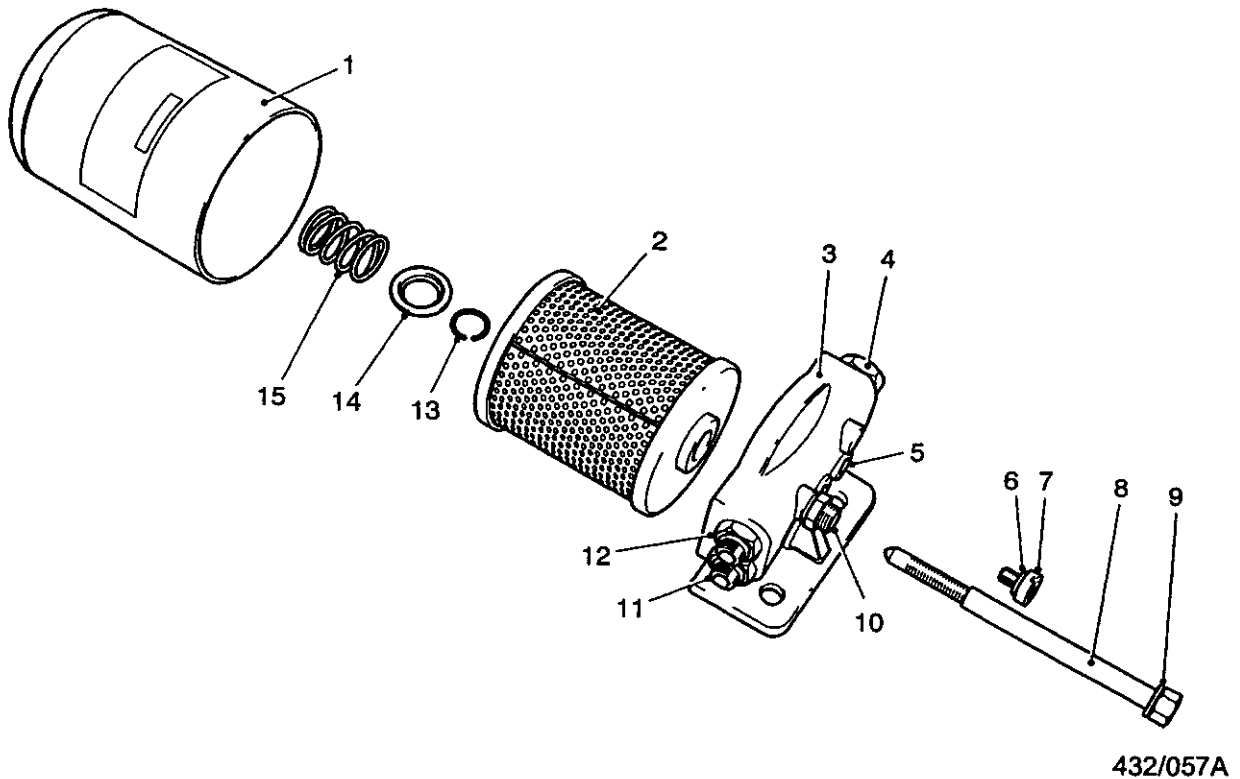

1	Bowl	9	Washer
2	Element	10	Leak 'OFF' connection
3	Head	11	Outlet
4	Plug	12	Inlet
5	Air bleed orifice	13	Circlip
6	Rubber washer	14	Spring seat
7	Air bleed screw	15	Spring
8	Centre bolt		

Fig 5 Fuel filter

ENGINE SPEED AND FUEL CUT OFF CONTROLS

Accelerator pedal and linkage

15 The accelerator pedal (Fig 6 (9)) mounted on the quadrant plate shaft (8) is located on a bracket welded to the half shaft cover (14) in the driver's compartment. An adjuster is provided to enable the accelerator pedal angle to be varied to suit the driver's attitude, which changes with the seat position. A knurled locking nut (12) with serrated washer and tension spring (11), clamps the pedal to the serrated face of the quadrant plate (10) in the required position. Two adjustable stops (15) restrict the pedal operating movement to within the required "OFF to ON" movement of 22 deg. The rod (17) attached to the accelerator pedal by a knuckle joint (13) connects by a slotted fork end (18) and pin with the lower cross shaft (22) located below the drivers compartment floor (27), a wire extension spring (19) secured to the fork end and anchored to the vehicle plate performs the accelerator pedal return action, the guard plate (16) bolted over the rod prevents damage from the drivers foot. Each end of the cross shaft is supported in a spherical bearing (20) which is bolted to its adjacent vehicle plate, pipes connect the bearing with two lubricating nipples (21) which form the last two of a battery of five mounted to the right of the steering levers. The cross shaft passes through a hole in the power pack compartment lower plate and clamped to the protruding shaft end is a lever (24) which has a rod (26) attached by knuckle joints connecting it with a lever (32) integral with the upper cross shaft (37), a spring (25) is provided to give the linkage return action. The upper cross shaft located below the power pack sill plate, has a lever (38) clamped to its inner end that connects via a rod (39) with knuckle joint attachments to the fuel injection pump governor control lever (40)

Hand control

16 The hand control positioned on the power pack compartment sill to the rear of the gear range selector lever, provides the means to adjust the engine speed to the required level, and comprises of a knurled screw (Fig 6. (36)), having a tensioning spring (35) and a locking wingnut (34), that fits into a threaded bracket (33) bolted to a hole in the sill plate, the nose of the screw makes contact with the cross shaft connection lever (32). When the screw is turned the resulting movement is transmitted via a cross shaft and linkage to the injection pump governor speed control lever (40). To allow the linkage to move independently from the accelerator pedal when the hand control is operated, the pedal linking the rod fork end (18) connection is slotted.

Fuel stop control

17 A fuel stop control (Fig 6) is provided to overcome a fault in the injection pump governor hydraulic circuit, which causes the engine to 'run away'. The control is operated by a foot pedal (29) that pivots from a bracket positioned to the left of the accelerator pedal, a wire extension spring (28) provides the pedal return action, and a flexible cable (7) routed across the front of the steering unit into the power pack compartment is connected to a quick release knuckle joint (5) to an intermediate lever (4) mounted on a bracket (3) bolted to the power pack frame. A fork ended operating link (2) connects the intermediate lever with the fuel cut-off lever (1) located on the left side of the injector pump governor (41). The operating cable is secured by clips and an anchor plate (6) to the steering unit. A momentary depression of the stop pedal allows the injection pump to return to zero.

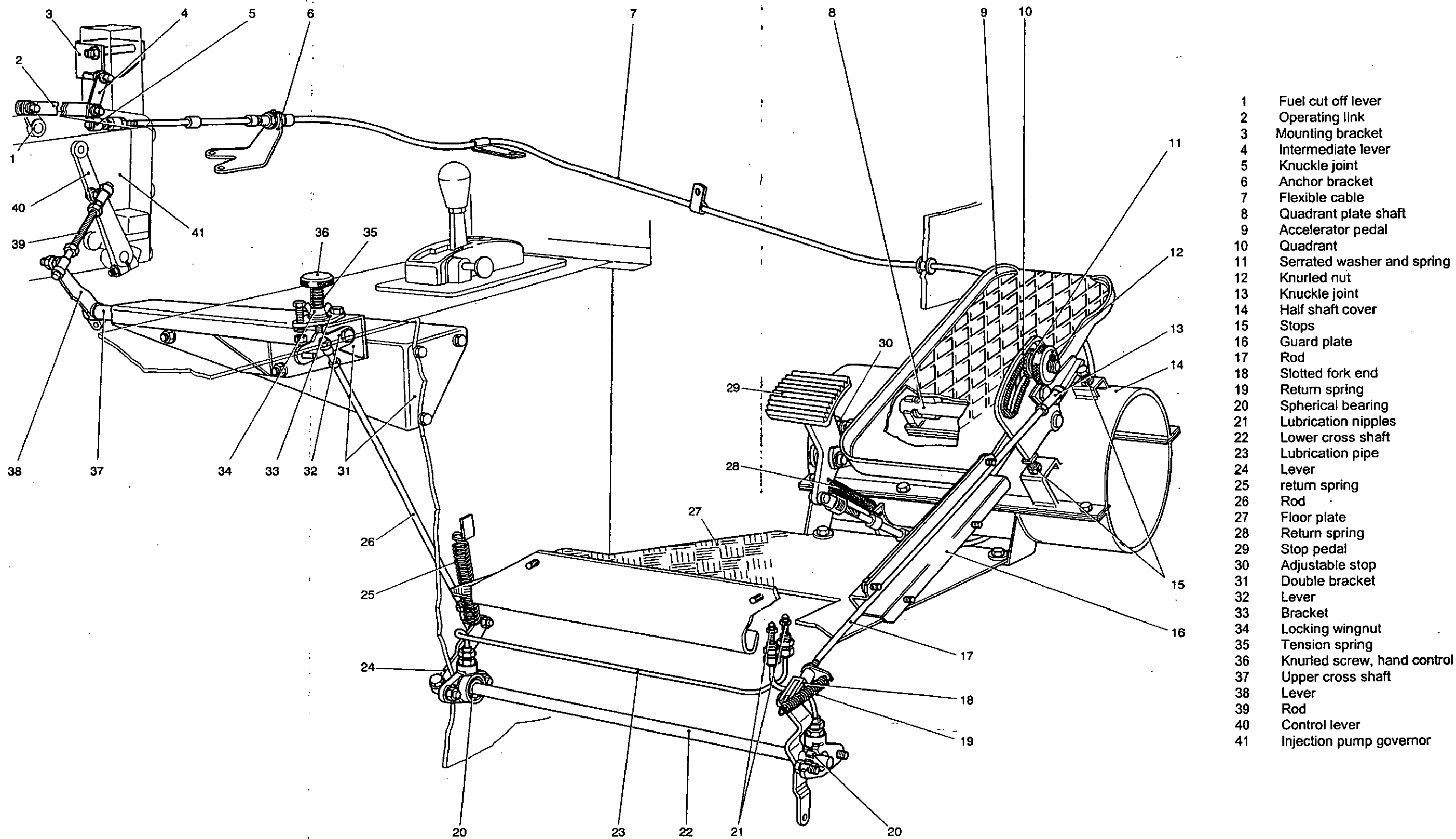

- 1 Fuel cut off lever
- 2 Operating link
- 3 Mounting bracket
- 4 Intermediate lever
- 5 Knuckle joint
- 6 Anchor bracket
- 7 Flexible cable
- 8 Quadrant plate shaft
- 9 Accelerator pedal
- 10 Quadrant
- 11 Serrated washer and spring
- 12 Knurled nut
- 13 Knuckle joint
- 14 Half shaft cover
- 15 Stops
- 16 Guard plate
- 17 Rod
- 18 Slotted fork end
- 19 Return spring
- 20 Spherical bearing
- 21 Lubrication nipples
- 22 Lower cross shaft
- 23 Lubrication pipe
- 24 Lever
- 25 return spring
- 26 Rod
- 27 Floor plate
- 28 Return spring
- 29 Stop pedal
- 30 Adjustable stop
- 31 Double bracket
- 32 Lever
- 33 Bracket
- 34 Locking wingnut
- 35 Tension spring
- 36 Knurled screw, hand control
- 37 Upper cross shaft
- 38 Lever
- 39 Rod
- 40 Control lever
- 41 Injection pump governor

Fig 6 Engine speed and fuel cut off control

CHAPTER 1-4
COOLING SYSTEM
CONTENTS

Para

- 1 Cooling system
- 2 Radiator
- 4 Heat exchanger
- 10 Fan drive
- 14 Fan drive pump
- 20 Operation
- 21 Fan motors
- 23 Air cleaner

Fig

Page

1	Coolant connections	2
2	Heat exchanger flow diagram	4
3	Hydraulic fan drive connections	5
4	Diagrammatic representation of hydrostatic fan drive circuits	6
5	Fan drive pump	8
6	Fan motor	9
7	Air cleaner	11
8	Air cleaner flow diagram	12

COOLING SYSTEM

1 The cooling system is one in which liquid is utilized to absorb heat from the engine by being circulated round the cylinders and is then cooled again by being passed through a radiator. Before re-entering the engine it is circulated through a heat exchanger where, dependent on the relative temperatures, it cools or warms the engine oil, gearbox oil, steering unit oil and hydraulic oil for the fan drive. Circulation of the coolant is by thermo-siphon action and an impeller type pump. A thermostat fitted in the outlet on the engine causes the fan controller, radiator and heat exchanger to be by-passed while the engine is warming up so that the rise will be more rapid to an efficient working temperature. When this temperature is reached, the control unit in the coolant and fan drive circuits, operates, allowing oil to flow to the fan motors causing the fan to start rotating. The fans draw air in through the inlet louvres and radiator, round the engine and expels it through the outlet louvres. The fan speed is varied by the control unit to maintain the engine coolant at an efficient working temperature. Layout and connections are illustrated in (Fig 1).

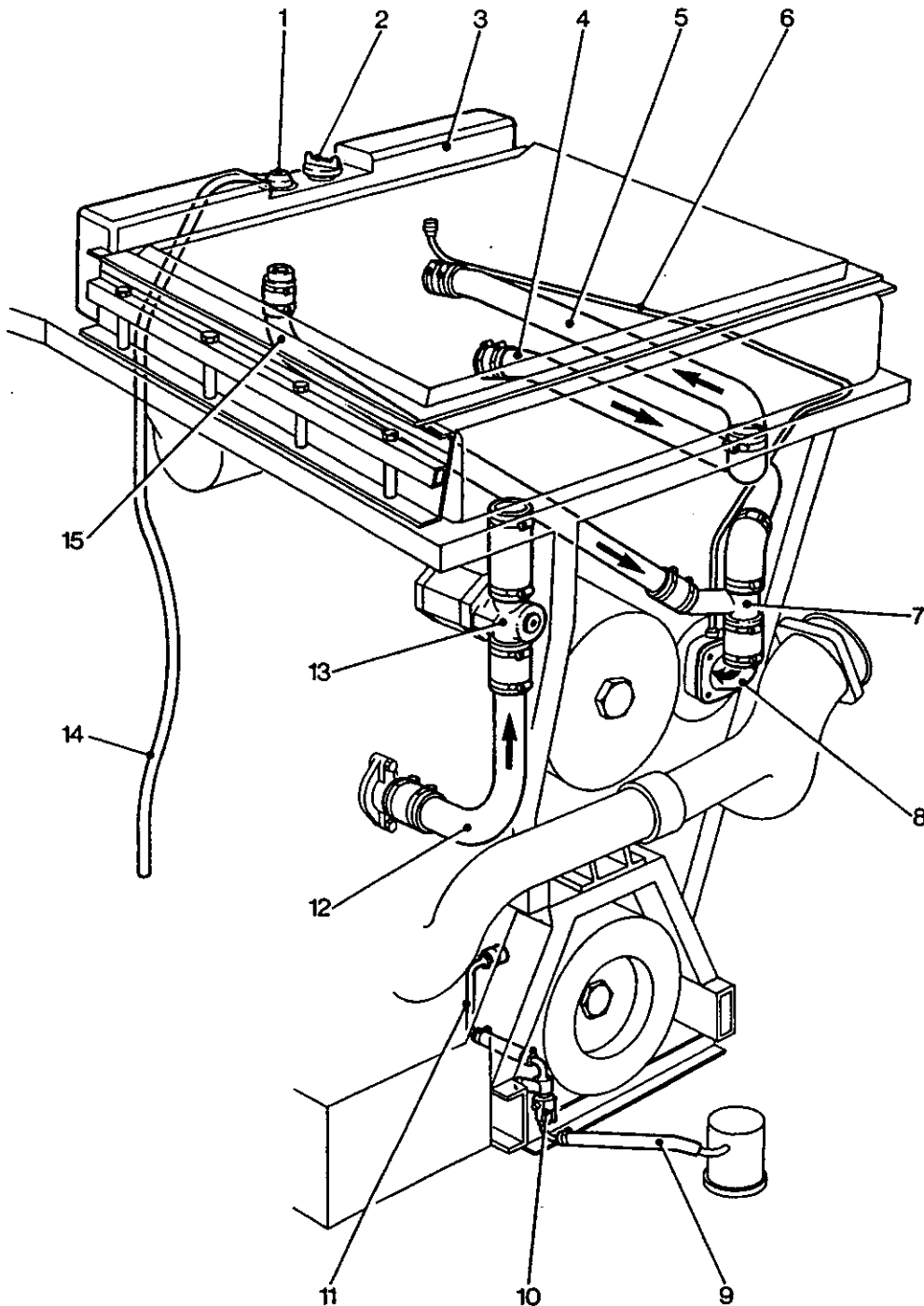

432/229

- | | | | |
|---|--|----|---|
| 1 | Pressure vacuum relief valve | 8 | Coolant pump connection |
| 2 | Filler cap | 9 | Connecting pipe to hull drain plug |
| 3 | Radiator header tank | 10 | Drain cock |
| 4 | Heat exchanger coolant outlet to pump | 11 | Cylinder block drain pipe |
| 5 | Heat exchanger coolant inlet from radiator | 12 | Engine thermostat controlled outlet to radiator |
| 6 | Vent tube from pump to header tank | 13 | Fan controller connection |
| 7 | Branch connection | 14 | Relief valve vent pipe extension |
| | | 15 | Header tank to pump |

Fig 1 Coolant connections

Radiator

2 The radiator is a two pass type in which the coolant passes up and down the matrix. The lower header tank is partitioned having the inlet connector tube (Fig 1(12)) in the lower section (below the partition) and the outlet connector tube (5), which passes, through the lower section and into the upper section.

3 The upper header tank (3) has a filler neck with a quick-release screw-on cap (2), and a pressure/vacuum relief valve (1), the main valve of which, opens at a pressure between 0.66 bar – 0.83 bar (9.5 lbf in² – 12 lbf in²), and the inlet valve at a depression of 0.04 bar – 0.11 bar (0.5 lbf in.² to 1.5 lbf in.²). In the bottom of the tank on the left is a connection for a vapour release pipe (6) leading from the water pump impeller housing, and centrally positioned is a connector for a branch pipe (15) leading to the pump inlet/heat exchanger outlet pipe (4) connection (7)

Heat exchanger

4 The function of the assembly is the exchange of heat between oil and coolant systems, the coolant is circulated through a series of tubes positioned longitudinally through the assembly whilst the oil systems are directed under pressure to and from the various sections of the assembly. The sections are secured by through bolts; each section is a separate unit in respect of oil but common to the assembly in respect to coolant. The engine and main gearbox sections are designed with a relief valve to relieve and by-pass oil to the outlet connection should the section be choked or blocked.

5 The heat exchanger consists basically of four separate heat exchanging units which form two cylinders clamped, by means of tie bars, between a transfer tank at one end and the inlet and outlet heads at the other end.

6 The heat exchanger is mounted on the power pack superstructure in two brackets, which cradle the two cylinders latitudinally below the radiator upper header tank. The rearmost cylinder is suspended at a higher level than the forward one.

7 Each of the four units is self contained and sealed from the other units. The coolant passes through numerous pipes axially located in honeycomb formation in each unit, it passes through the rear cylinder tubes into the transfer tank then through the front cylinder tubes to the outlet head in a single pass.

8 Oil under pressure from the separate systems is channelled to the relevant unit inlets and passed around baffle plates surrounding the coolant tubes through which the water is passed under the influence of the coolant pump - to leave via the outlet connections for re-circulation within its own particular system.

9 The length of each unit is proportional to the amount of oil heat distribution required. Two of the units, the engine and gearbox, each embody a pressure relief valve; the engine section relief valve (9) is set to open at 3.45 bar (50 lbf in²) whilst the gearbox section relief valve (3) is set to open at 1.04 bar (15 lbf in²). Oil passing to these two units under pressure in excess of the valve settings lifts the ball valve from its seating and creates a passage direct from the inlet connector body to the outlet connector body.

Fan drive

10 The fans are driven hydraulically (Fig 3) and the system comprises a pump (11), a motor (5 and 21) for each fan, a controller unit (3) incorporating a by-pass valve and a pressure relief valve and a tank (17) for the fluid. The fluid is passed through a section of the heat exchanger before being returned to the tank. The system is illustrated diagrammatically in (Fig 4).

11 The pump is a fixed displacement type and is shaft driven from the rear end of the speed limiter on the engine. The controller is connected in both the coolant circuit and the hydraulic circuit and operates thermally. The thermostatic element in the controller is immersed in coolant, which, as it gets hot, causes the element to expand and gradually close the controller by-pass valve, which is in the hydraulic circuit. The valve is adjusted so that while the engine is running and the coolant temperature is not high enough to operate the control unit element, the fans are rotated slowly to ventilate the power pack compartment.

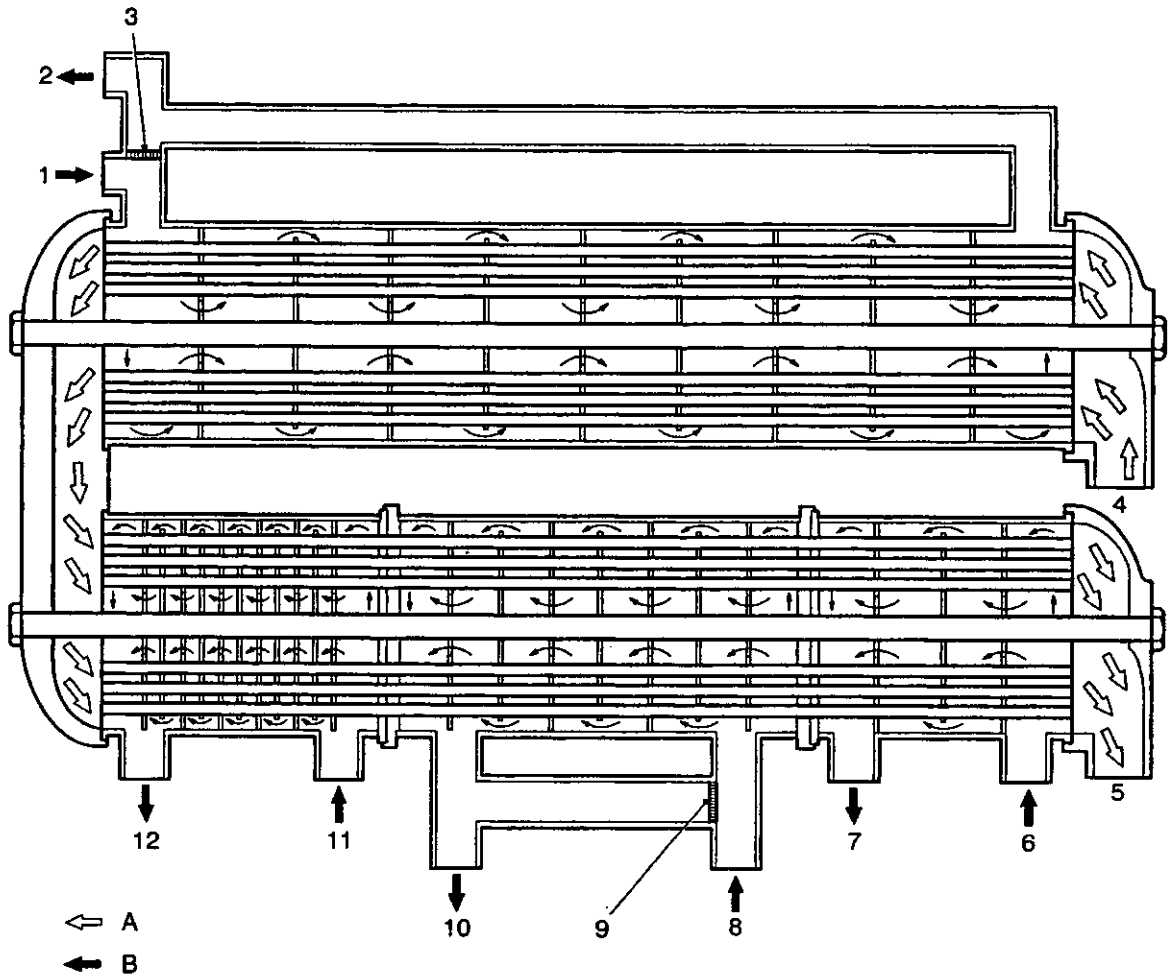

432/230

- | | | | |
|---|------------------------------|----|-------------------------------|
| 1 | Oil inlet - gearbox section | 8 | Oil inlet - engine section |
| 2 | Oil outlet - gearbox section | 9 | Relief valve |
| 3 | Relief valve | 10 | Oil outlet - engine section |
| 4 | Water (coolant) inlet | 11 | Oil inlet - steering section |
| 5 | Water (coolant) outlet | 12 | Oil outlet - steering section |
| 6 | Oil inlet - fan section | A | Water (coolant) circuit |
| 7 | Oil outlet - fan section | B | Oil circuits |

Fig 2 Heat exchanger, flow diagram

12 When the engine is started from cold, the pump is rotated and fluid is drawn from the tank and delivered to the circuit. As the controller by-pass valve is almost wide open most of the fluid is returned to the tank via the section of the heat exchanger, so bypassing the fan motors. When the coolant temperature reaches that to which the controller is pre-reset, the expanding element further closes the by-pass valve and more fluid is diverted to the fan motors, which as the pressure builds up, begin to rotate faster. The heat of the coolant continues to close the by-pass causing the speed of the fans to increase until sufficient cooling is obtained to maintain the coolant at the pre-selected temperature.

13 Should unduly high pressure be developed, the pressure relief valve will be opened and the fluid by-passed back to the tank. Maximum fan speed is normally attained before maximum engine speed. When the pump delivery exceeds the requirement of the fan motors running at maximum speed an excessive pressure is developed which opens the relief valve and the surplus fluid is bypassed back to the tank.

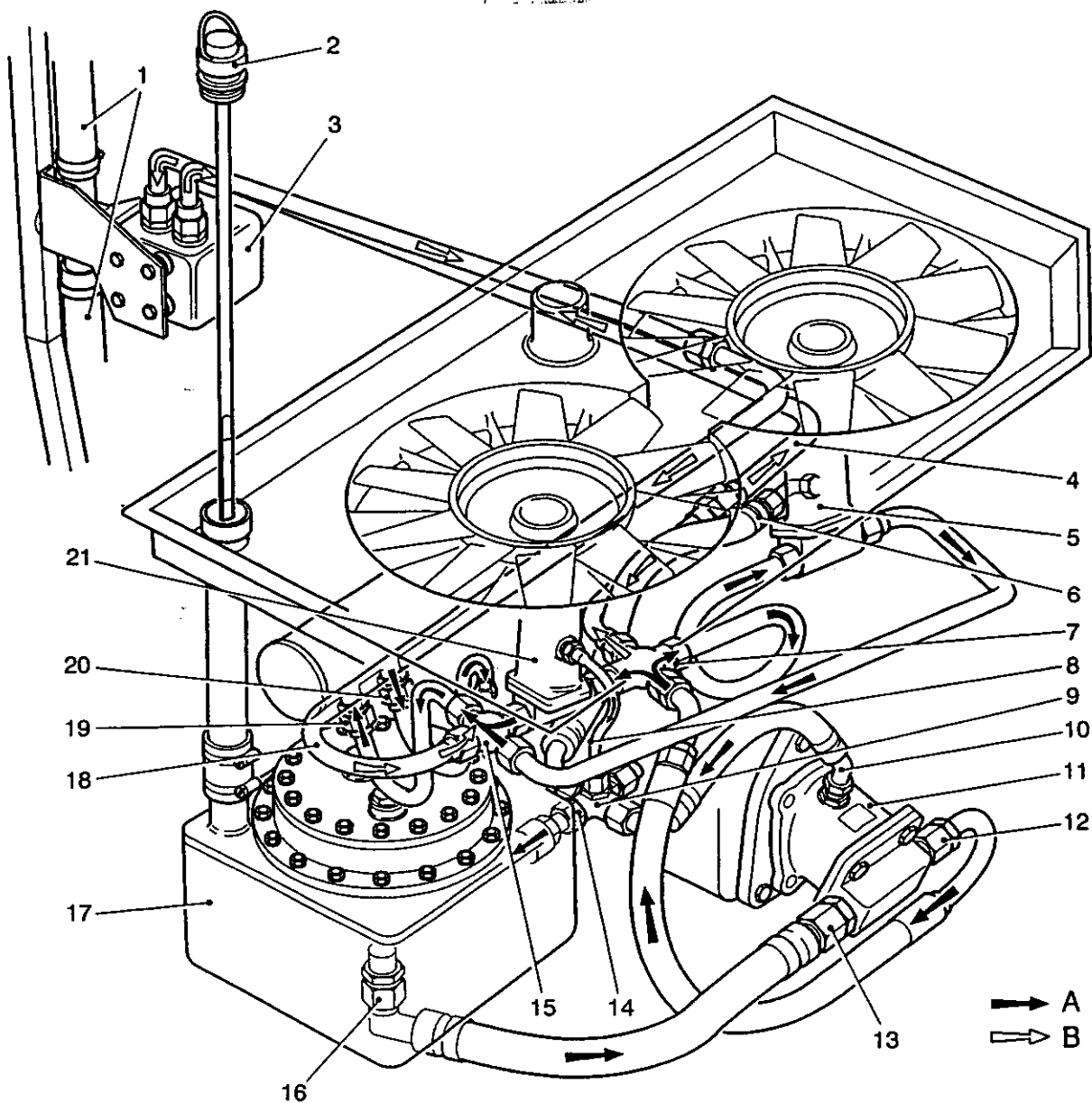

432/231

- | | | | |
|----|--------------------------------------|----|---|
| 1 | Coolant pipe from engine to radiator | 13 | Pump inlet |
| 2 | Filler plug/dipstick | 14 | Leak-off return connection |
| 3 | Fan controller | 15 | Equal cross adaptor |
| 4 | By-pass to controller | 16 | Outlet to pump |
| 5 | Right fan motor | 17 | Hydraulic fluid tank |
| 6 | Fan motor leak-off | 18 | By-pass from controller |
| 7 | Equal cross adaptor | 19 | Inlet to head exchanger from equal cross adaptor (15) |
| 8 | Fan motor leak-off | 20 | Outlet from heat exchanger to fluid tank |
| 9 | Cross adaptor with test point | 21 | Left fan motor |
| 10 | Pump leak-off | | |
| 11 | Pump | A | Fan drive flow |
| 12 | Pump outlet | B | By-pass flow via |

Fig 3 Hydraulic fan drive connections

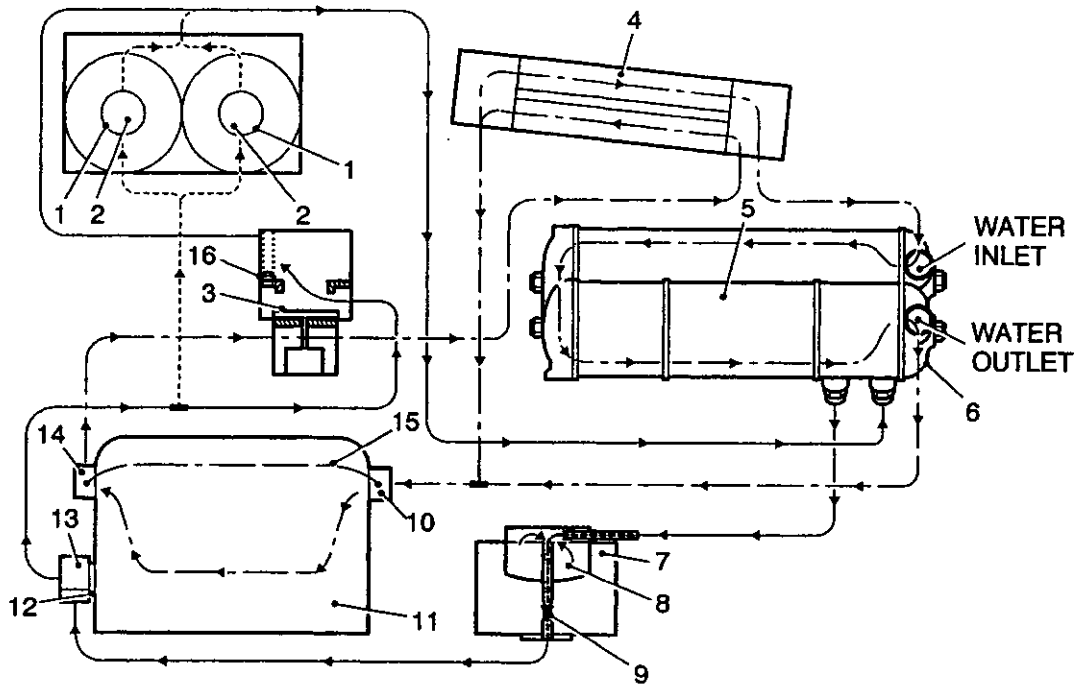

VALVE OPEN FANS STOPPED

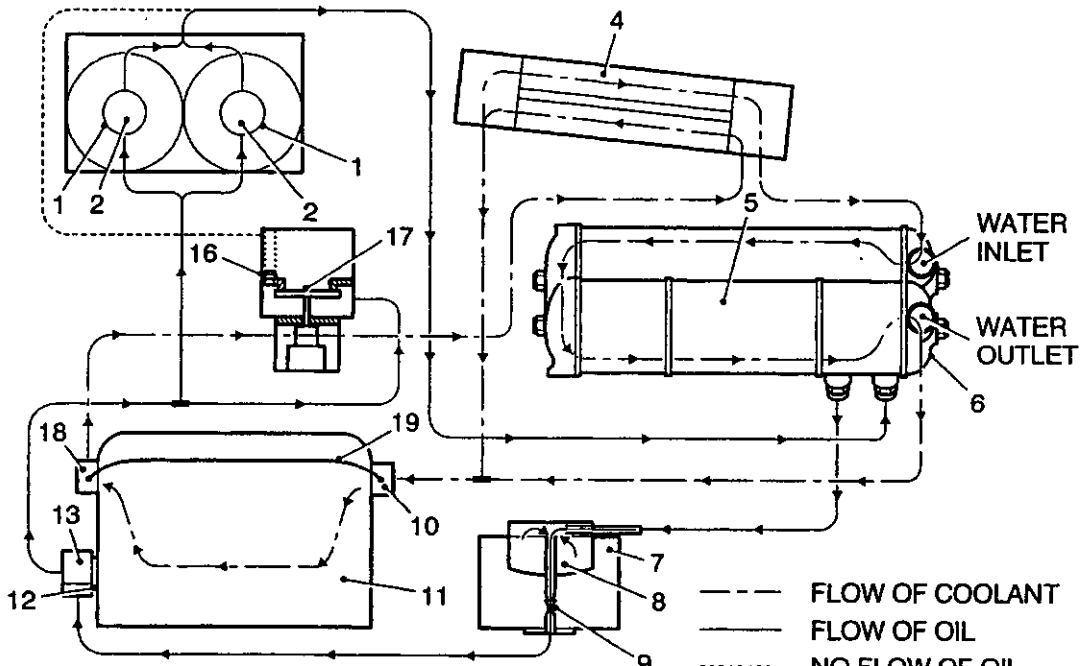

VALVE CLOSED FANS RUNNING

--- FLOW OF COOLANT
— FLOW OF OIL
- - - NO FLOW OF OIL

432/232

- | | | | |
|----|---|----|------------------------------|
| 1 | Fan motor leakage port | 11 | Engine |
| 2 | Fan motors | 12 | Oil pump leakage port |
| 3 | Fan controller valve, open | 13 | Oil pump |
| 4 | Radiator | 14 | Thermostat, closed |
| 5 | Heat exchanger water inlet / outlet section | 15 | By-pass in operation |
| 6 | Heat exchanger fan drive oil inlet / outlet section | 16 | Relief valve |
| 7 | Oil tank | 17 | Fan controller valve, closed |
| 8 | Inner tank | 18 | Thermostat, open |
| 9 | Venturi | 19 | By-pass, inoperative |
| 10 | Water pump | | |

Fig 4 Diagrammatic representation of hydrostatic fan drive circuits

Fan drive pump

14 The pump body comprise three parts, one part housing the drive shaft and its bearings, the middle part housing the cylinder block, pistons, and piston rods, and the other part forming the control cone on which the cylinder block rotates. When assembled, the axis of the cylinder block housing (Fig 5 (17)) is oblique to that of the drive shaft (36) so that when the drive shaft is rotated the end acts as a swash plate and gives a reciprocating motion to the pistons (15) in the cylinder block (25). The three parts are secured together by screws and spring washers, fitted into tapped holes in the cylinder block housing flanges.

15 The drive shaft housing (10) is bored to four diameters to receive an oil seal housing (33) the outer race of a ball journal bearing (32) which supports the small end of the drive shaft, the fixed race of a ball thrust bearing (8) and the outer race of a roller bearing (9) which carries the large end of the drive shaft. A clearance, which provides a path for oil, is machined for the rotating face of the thrust bearing. The oil seal housing receives a sealing ring (34) and a seal (4), which wipes on a sealing bush (35) on the shaft. The housing is held against the drive shaft housing end face by six inset screws (3) and spring washers. A sealing ring (2) fitted in a groove in the drive shaft, seals between the bush and the shaft. Lubrication of the small journal bearing is by passages drilled in the shaft. A distance piece (6) is interposed between the fixed races of the ball and thrust bearings. An abutment on the shaft transfers thrust to the rotating race of the thrust bearing. The inner race of the roller bearing is located by a circlip (31) on the shaft and a second drive shaft abutment. The outer race is located by a distance piece (11) between the race and the spigot on the cylinder block housing flange. The protruding end of the drive shaft is keyed to fit a driving flange and the end tapped for a screw by which the driving flange is secured. When assembled, the driving flange must contact the sealing bush to lock it in position.

16 The cylinder block housing is bored parallel to receive the cylinder block and flanged to attach the control cone (21) on which the cylinder block rotates. The inlet and delivery connections (22) are provided on the control cone.

17 The ports (38 and 39) in the control cone are kidney shaped, one being the inlet, the other one the delivery, and pass through the cone to the convex face which is in contact with the concave end of the cylinder block. At each end of the ports the edge is notched (43) to reduce hydraulic hammer as the cylinder ports and control cone ports begin to overlap. The convex face has oil grooves (23), which ensure proper lubrication between the contacting surfaces.

18 The cylinder block is keyed to a spherical headed spindle (16), which passes centrally through it, the head being located in a hemi-spherical recess in the centre of the drive shaft end face and the other end in the control cone. A shoulder below the head forms seating for a coil spring (13), which balances the weight of the cylinder block. The spherical surfaces of the cylinder block and the control cone are lapped together, and are special design to give automatic hydraulic adjustment of clearance between the block and the cone. It is essential that these finely finished surfaces should be unmarked.

19 The seven pistons are identical and reciprocate in seven cylinders bored in the block. The top of each cylinder forms a port, which as the block rotates, follows a path, which keeps it over the kidney shaped ports in the convex face of the control cone. Each piston is connected to a rod (29) one end of which is attached in the hollow piston by a securing ring and two locking pins. The other end of the piston rod is spherical and fits into a semi-spherical recess in the end of the drive shaft. The recesses for the piston rods are disposed equally round that for the centre pin and the spherical ends are retained in the recesses by spherically bored collars (12) which are held by a plate (30) secured to the drive shaft end by instrument headed screws. Each spherical end is lubricated through a hole drilled longitudinally in the rod and a hole drilled transversely through the piston. Individual circumferential oil control grooves are cut on the outside of each piston. After the pump body is filled with oil, the surplus is returned to the lower tank through a pipe connected to a leak-off outlet (14) in the cylinder block housing. The leak-off rate is a definite quantity and gives an indication of the condition of the pump.

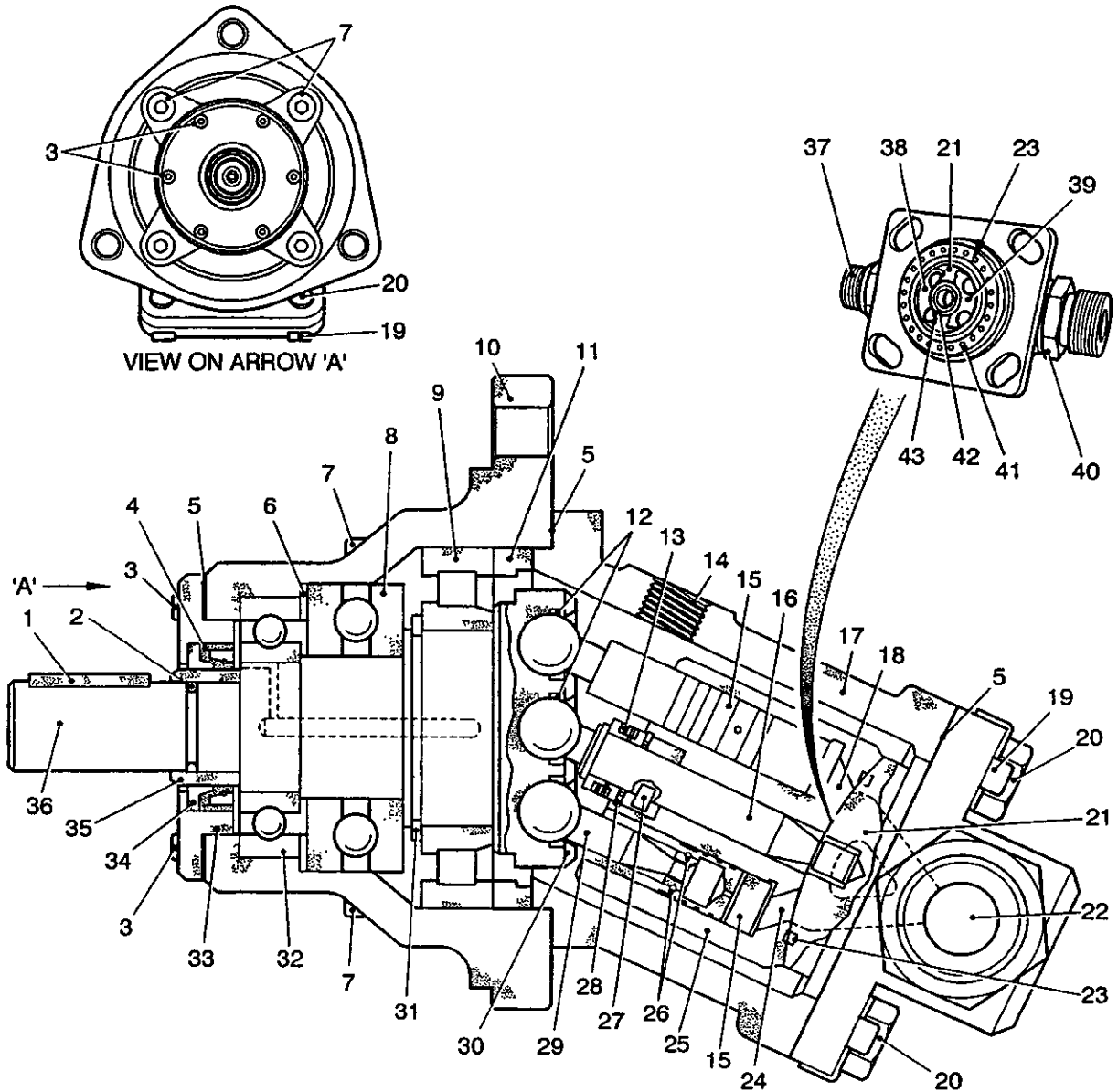

432/233

- | | | | | | |
|----|---|----|---------------------------------------|----|------------------------------|
| 1 | Drive shaft key | 15 | Piston | 29 | Piston rod |
| 2 | Sealing ring | 16 | Spherical headed spindle | 30 | Collar retaining plate |
| 3 | Screw (oil seal housing to drive shaft housing) | 17 | Cylinder block | 31 | Circlip |
| 4 | Oil seal | 18 | Inlet port | 32 | Roller bearing |
| 5 | Joint | 19 | Tab washer | 33 | Oil seal housing |
| 6 | Distance piece | 20 | Bolt (control cone to cylinder block) | 34 | Sealing ring |
| 7 | Screw (drive shaft housing to cylinder block housing) | 21 | Control cone | 35 | Sealing bush |
| 8 | Thrust bearing | 22 | Inlet port | 36 | Drive shaft |
| 9 | Roller bearing | 23 | Oil groove | 37 | Delivery union |
| 10 | Drive shaft housing | 24 | Outlet port | 38 | Kidney shaped port, delivery |
| 11 | Distance piece | 25 | Cylinder block | 39 | Kidney shaped port, inlet |
| 12 | Collar | 26 | Pins | 40 | Inlet union |
| 13 | Coil spring | 27 | Key | 41 | Oil indentations |
| 14 | Leak-off outlet | 28 | Securing ring | 42 | Bush |
| | | | | 43 | Anti-knock notch |

Fig 5 Fan drive pump

Operation

20 When the engine rotates the drive shaft, the spherical ends of the piston rods are carried round so rotating the cylinder block. As the drive shaft and cylinder block are not on the same axis, each of the seven pistons is pushed into and withdrawn from its cylinder during each revolution. While being withdrawn, the port in the top of the cylinder is over the inlet port in the control cone and the displacement of the piston is filled with oil. When the piston is at its maximum withdrawal, the cylinder port passes off the inlet port so sealing the cylinder. As the cylinder block is rotated further, the piston is pushed into the cylinder and the cylinder port comes over the delivery port in the control cone to allow the oil to be pushed into the circuit.

Fan motors

21 The fan motors are each constructed with a one piece casing (Fig 6 (15)). The fan shaft (21) is supported at each end by a ball journal bearing and thrust is opposed by a central ball thrust bearing (17) and three bearings being carried in a separate housing (5) inserted in the main casing and retained by an internal circlip (19).

22 The housing is sealed in the casing by an O-ring (4). A shouldered distance piece (7) is interposed between the rotating race of the inner bearing (16) and the rotating race of the thrust bearing, the shoulder being used to centralise the thrust race. The bearing housing is relieved to permit the passage of oil through the thrust bearing. Between the fixed race of the thrust bearing and the fixed race of the outer bearing (18) is another distance piece (6). Oil also reaches the outer bearing via passages drilled in the shaft. An oil seal (3) prevents leakage along the shaft. In other respects the fan motors resemble the pump but the motor is of smaller displacement and reverse in operation. The high pressure feed from the pump is connected to the control cone ends (14) of the motors and the fans are mounted on the shafts. The leak-off pipes from the cylinder block housings lead to a common pipe, which goes direct to the lower fluid tank.

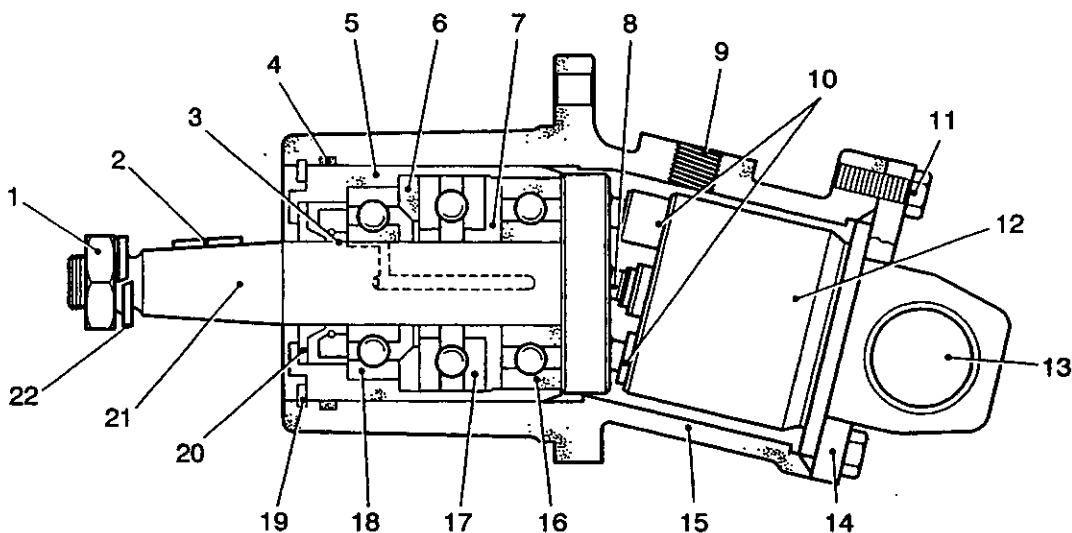

432/234

1	Fan retaining nut	8	Spherical headed spindle	14	Control cone end
2	Woodruff key	9	Leak-off outlet	15	Fan motor casing
3	Oil seal	10	Pistons	16	Inner bearing
4	Sealing ring	11	Screw (control cone housing to motor casing)	17	Ball thrust bearing
5	Bearing housing	12	Cylinder block	18	Outer bearing
6	Distance piece	13	Delivery/outlet port	19	Internal circlip
7	Shouldered distance piece	20	Sealing ring	21	Fan shaft
		22	Spring washer		

Fig 6 Fan motor

AIR CLEANER

23 The air cleaner (Fig 7 and Fig 8) is a two stage dry type unit mounted above the engine blower unit and supported by the power pack superstructure. When the power pack is mounted in the vehicle the cleaner is enclosed by a two part cover, one part (Fig 7 (8)) attached to the hull, and the other to the power pack frame, this cover is fitted with seals to ensure only air from outside the vehicle enters the cleaner via the louvres.

24 The first stage compartment (6) contains a battery of 67 cyclone extractor tubes mounted between two baffle plates. Each cyclone tube (14) consists of two parts, a body (4) and a cap (5). The body has a divergent nozzle shape with vanes disposed externally round the inlet end and the tube cap is slid over the vanes; both ends of the assembly are a snap fit in their respective baffle plates.

25 The cap ends of the tubes protrude into an end chamber (9), a pipe passing into the bottom of this chamber is connected by a hose (13) to the engine air chest, and air from the blower passes through it to a venturi tube (11) at the chamber outlet, this produces a scavenging effect in the chamber.

26 When air is drawn into the chamber it enters through a perforated screen and passes through the extractor tube vanes, which impart a swirling effect, it is then drawn into the body of the tube. Due to the momentum gained by the heavier dust particles in the air, the change in direction of the air as it is sucked into the tube causes them to depart from the main stream and they are expelled through the cap ends into the end chamber where they fall to the bottom and are blown out of the venturi outlet by the air by-passed from the blower.

27 The baffle plate supporting the outlet ends of the tube bodies forms the partition between the stages. The second stage compartment (3) houses the two replacement paper elements (21) by which the remaining dust is extracted. The air cleaner is connected to the blower unit by an outlet casting (19) bolted to the outlet chamber and a flexible coupling (15).

28 The elements are threaded over centre bolts attached to brackets mounted on a platform. The air drawn through the elements passes into the outlet chamber below the platform and then through the outlet casting to the blower unit. Each element consists of a paper filter supported by an inner and an outer tube of wire mesh between a dished top plate and an annular bottom ring. Fitted in the centre of the top plate is a captive wing nut, which secures the element in position, and diagonally opposite each other at the edge of the dished recess are two 'D' rings for use when replacing or removing the elements. A sealing ring is attached by adhesive to the annular ring to form a seal between the element and the platform. Two covers (2) retained by captive wing nuts and sealed by rubber rings affixed with adhesive, give access to the paper elements.

29 An indicator unit (1) mounted on the fan cowling is connected by a small bore pipe (20) to the outlet casting. The indicator is only visible when the engine air outlet louvre is open. The purpose of the indicator is to give a visual warning of dust build up on the elements, when the restriction to the air flow has increased sufficiently to commence to become choked and as the pressure drop increases, the green sleeve (18) is drawn into the body exposing the red warning section (16). When the pressure drop reaches the limit the red section becomes fully exposed, the green sleeve is automatically locked open by a small permanent magnet. When this stage has been reached the elements must be replaced or cleaned. The elements are not washable but can be cleaned effectively, if a replacement is not available, by shaking all the dust possible from them. When the elements have been replaced or cleaned the indicator must be reset by pressing the rubber covered button (17) at the end of the unit, which parts the green sleeve from the magnet and allows it to cover the red section under normal pressure.

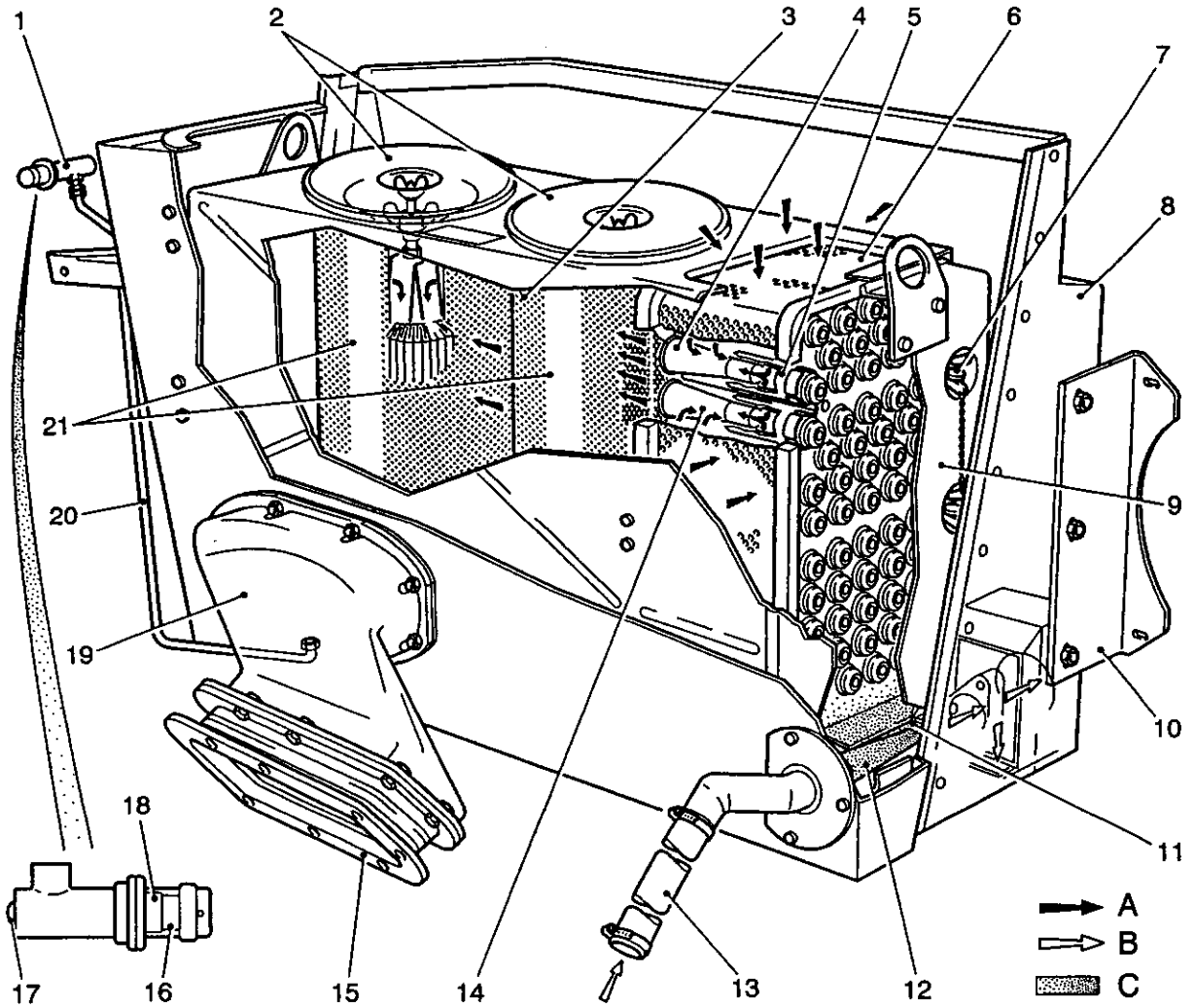

432/235

- | | | | |
|----|---|----|--------------------------------------|
| 1 | Indicator unit | 13 | Engine air chest connecting hose |
| 2 | Cover plates | 14 | Cyclone extractor tube |
| 3 | Second stage compartment | 15 | Flexible connection to engine blower |
| 4 | Body | 16 | Red indicator |
| 5 | Cap | 17 | Reset button |
| 6 | First stage compartment | 18 | Green sleeve |
| 7 | Baffle plate retaining stud and wingnut | 19 | Air cleaner outlet |
| 8 | Cover | 20 | Indicator connecting pipe |
| 9 | End chamber | 21 | Paper elements |
| 10 | Mounting bracket | A | Air flow from atmosphere to engine |
| 11 | Venturi tube | B | Air flow from air chest (blower) |
| 12 | Extractor tube | C | Dust particles |

Fig 7 Air cleaner

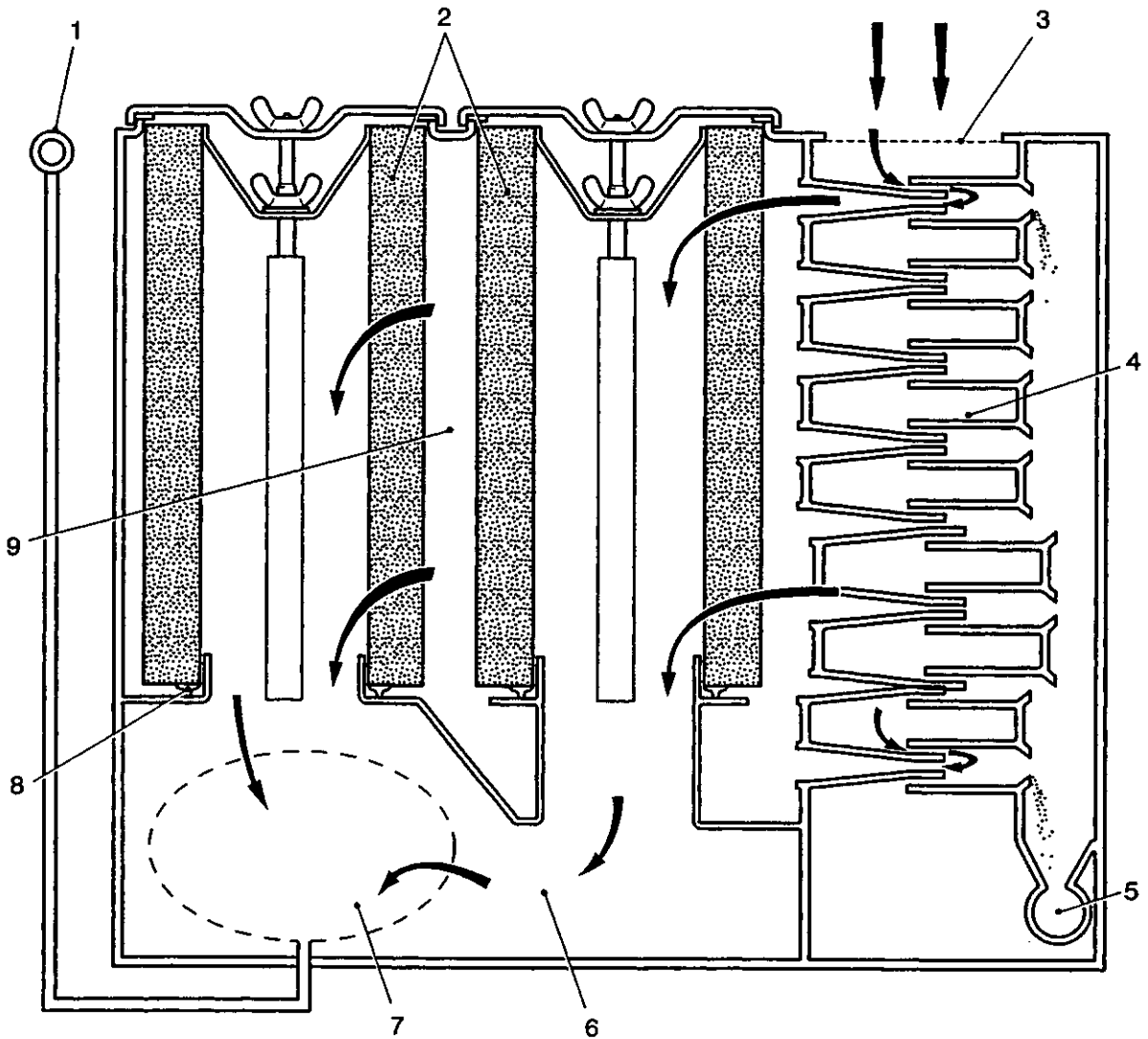

432/236

- | | | | |
|---|--|---|--------------------------|
| 1 | Restriction indicator unit | 5 | Dust extractor venturi |
| 2 | Replaceable paper elements | 6 | Outlet chamber |
| 3 | Air inlet | 7 | Air outlet to blower |
| 4 | First stage compartment containing
67 cyclone extractor tubes | 8 | Sealing ring |
| | | 9 | Second stage compartment |

Fig 8 Air cleaner flow diagram

CHAPTER 1-5
TRANSMISSION
CONTENTS

Para

- 1 General
- 5 Flywheel housing
- 7 Engine coupling
- 11 Transfer gearbox
- 12 Transfer drive
- 20 Dis-connector mechanism
- 22 Lubrication system
- 25 Gearbox
- 27 Torque Converter
- 32 Lock-up Clutch
- 36 Gear Range Selector
- 43 Operation
- 46 Propeller shaft
- 47 Steering unit
- 48 Differential assembly
- 55 Input bevel pinion
- 57 Brake mechanism
- 63 Brake adjustment
- 64 Lubrication system
- 71 Operation
- 72 Mounting
- 75 Oil tank, pipes and fittings
- 81 Brake and steering controls
- 87 Parking control
- 88 Lubrication system
- 90 Operation
- 94 Half shaft assemblies
- 98 Throttle valve actuator

Fig

Page

1	Layout of transmission.....	2
2	Rear view engine coupling and flywheel housing	3
3	Engine coupling and flywheel housing.....	4
4	Oil feed pipe.....	6
5	Three-quarter front view of Allison gearbox.....	7
6	Transfer gearbox	9
7	Three-quarter rear view of Allison gearbox	10
8	Torque Converter operation – stator stationary.....	11
9	Torque converter operation – stator free wheeling	12
10	Gear range selector.....	13
11	Propeller shaft.....	14
12	Three-quarter front view of steering unit.....	15
13	Three-quarter rear view of steering unit.....	16
14	Broken perspective view of steering unit	19
15	Securing bolts at bevel wheel side of differential	20
16	Steering unit differential assembly	20
17	Brake mechanism.....	22
18	Steering unit oil pump - exploded view	24

(continued)

CONTENTS (continued)

Fig		Page
19	Operation of steering unit oil pump	25
20	Steering unit oil tank	26
21	Brake and steering controls	29
22	Half shaft assembly	30
23	Throttle valve actuator	32

GENERAL

1 The power from the engine (Fig 1 (10)) is transmitted rearward through a flexible coupling incorporated with the flywheel to a transfer gearbox (8) secured to the flywheel housing (9). Power from the transfer gearbox is directed forward at the right of the engine through an Allison automatic gearbox (7), also secured to the flywheel housing, and then through a propeller shaft (6) comprising two needle-roller universal joints to a controlled differential steering unit (4). The power from this unit is transmitted through half-shafts (3) and gear type couplings (2) to straight spur single reduction final drives (1) and (5) at left and right respectively.

2 The Allison gearbox incorporates a 3-element converter.

3 The transfer gearbox is provided with a dis-connector mechanism at its input end to facilitate engine starting under extreme cold conditions.

4 The flywheel housing, both gearboxes and propeller shaft are built with the engine on a sub frame to form part of the power pack. The engine is a K60, No.4, MK 4F and 6F, two stroke, multi fuel engine.

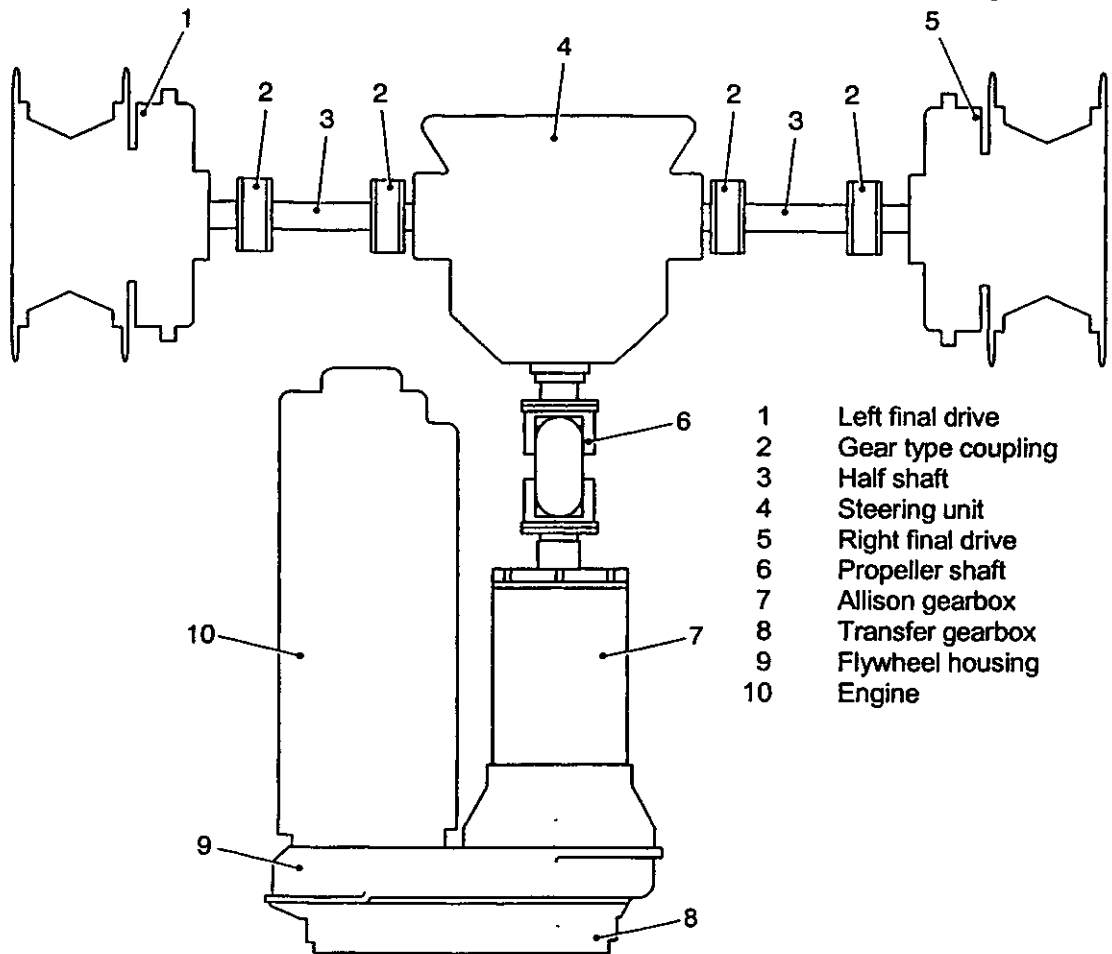

- 1 Left final drive
- 2 Gear type coupling
- 3 Half shaft
- 4 Steering unit
- 5 Right final drive
- 6 Propeller shaft
- 7 Allison gearbox
- 8 Transfer gearbox
- 9 Flywheel housing
- 10 Engine

432/274

Fig 1 Layout of transmission

FLYWHEEL HOUSING

5 The flywheel housing (Fig 2 (8)) is a machined iron casting and is dowelled and bolted to the engine crankcase and sump adaptor. The housing receives the transfer gearbox at the rear of the Allison gearbox at front right.

6 An aperture cover (2) provides access for attaching a laminated flexplate on the transfer gearbox output shaft to the pump cover of the Allison gearbox torque converter. Two setscrews secure a sheet steel cover over each aperture.

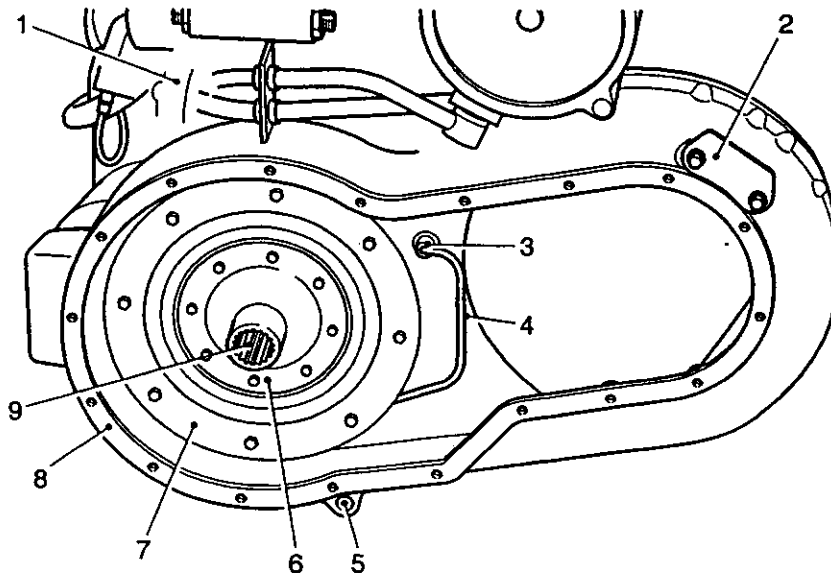

432/275

1	K60 engine	6	Engine coupling
2	Flexplate access aperture cover	7	Flywheel
3	Transfer tube	8	Flywheel housing
4	Feed pipe	9	Driving hub
5	Sump connection		

Fig 2 Rear view engine coupling and flywheel housing

ENGINE COUPLING

7 The engine coupling is of a flexible type comprising a Metalastik bush (Fig 3 (11)), which consists of a rubber bush bonded to two concentric steel members. The outer member is located on the flywheel by three roll pins (3) (i.e. split tubular dowels) and secured by eight setscrews each locked by a tab washer. Spigoted between the inner member and a stop plate (4) is a driving hub (13). The stop plate and driving hub, both located by a through roll pin (10), are secured to the inner member by eight through bolts with nuts locked by tab washers.

8 The driving hub is formed with internal splines at its rear end for receiving the driving shaft of the transfer gearbox or to permit its disengagement (Para 3). The inner end of the bore is blanked by a plug (14) fitted with an O sealing ring (15) and is retained by a circlip (16).

9 Located in each of the four spaces between the arms of the stop plate is a buffer stop (5), which is bolted to the flywheel and comprises two rubber pads bonded to the opposite facings of a steel body. Between each pad and adjacent arm of the stop plate is a static angular clearance of approximately five degrees or approximately 10.2 mm (0.4 in.) circumferentially.

10 The coupling, due to the Metalastik bush, provides a smooth take-up of the drive; it also dampens engine vibration and shock to the transfer gearing due to sudden acceleration. In the event of failure of the Metalastik bush, the leading ends of the buffer stops will come into contact with the stop plate and so transmit the drive. The flywheel rotation is anti-clockwise.

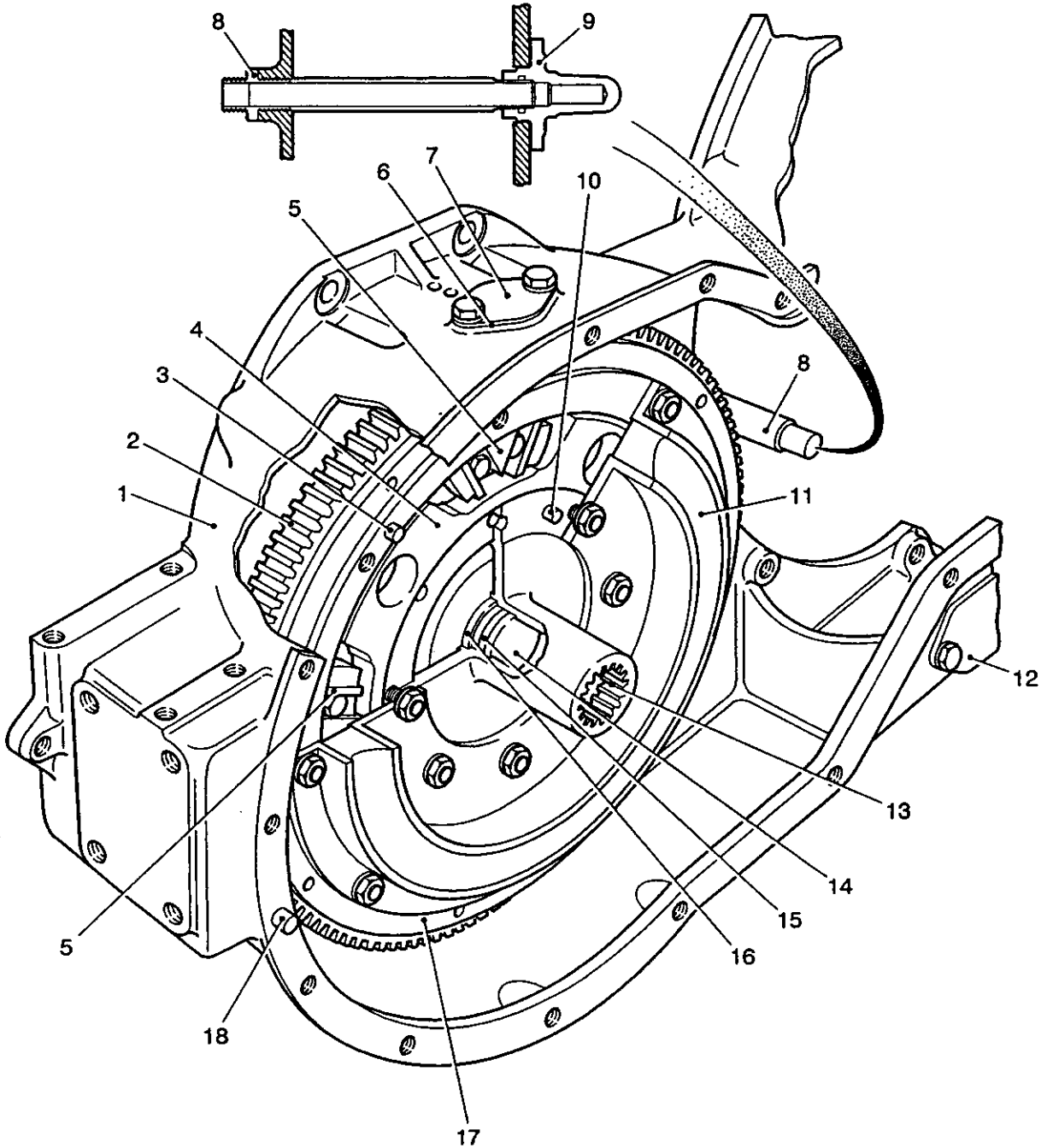

432/350

- | | | | |
|---|---------------------------------|----|---------------------------------|
| 1 | Flywheel housing | 10 | Roll pin |
| 2 | Starter ring gear | 11 | Metalastik bush |
| 3 | Roll pin | 12 | Access aperture cover |
| 4 | Stop plate | 13 | Driving hub |
| 5 | Buffer stop | 14 | Plug |
| 6 | Gasket | 15 | O sealing ring |
| 7 | Timing inspection cover | 16 | Circlip |
| 8 | Oil pipe | 17 | Flywheel |
| 9 | Centre oil jet transfer gearbox | 18 | Dowel locating transfer gearbox |

Fig 3 Engine coupling and flywheel housing

TRANSFER GEARBOX

11 The transfer gearbox, which is dowelled and bolted to the engine flywheel housing, comprises a simple train of four helical gears for transmitting the power from the engine to the Allison gearbox at engine speed. A mechanism is incorporated for disconnecting the engine drive from the gearbox to facilitate starting under extreme cold conditions. Lubrication is effected by means of oil jets fed by the engine scavenge pump. The oil is normally returned from the gearbox to the engine sump by a gear type pump driven through straight spur gears from the input gear of the main train. With the drive disconnected and the engine running, the oil is returned by an additional outlet and connecting pipe.

Transfer drive

12 The transfer drive comprises an input driving gear (Fig 6 (21)), an idler gear (27), a driven gear (26) and a coupling shaft gear (20). These gears are enclosed together in a split cast iron casing consisting of a front casing (57) and a rear casing (42) dowelled and bolted together with a metal-to-metal joint.

13 The driving gear is carried in a ball bearing (48) and a roller bearing (43). The ball bearing inner race and an oil pump gear (28) are clamped together on a long shaft portion of the gear by a locking nut (22) formed with a shroud or sleeve which is punched into two diametrically opposite slots in the shaft portion of the gear to lock the nut. The ball bearing outer race is stepped into a counter bore in the front casing and held in position by a bolted oil seal and bearing housing (14). The roller bearing inner race is held up to an abutment on the gear by a circlip (13) while the outer race, with its shrouded end facing rearwards, is located by the spigot of a bolted cover (55) in the bore provided in the rear casing.

14 The idler gear is supported by a smaller ball bearing (48) and an identical roller bearing as compared with the driving gear. The ball bearing inner race is secured up to an abutment on the gear by a shroud locking nut (22), while the outer race is held in the front casing bore between a circlip (44) and the spigot of a bolted cover (55). An identical cover is used to locate the roller bearing outer race in the rear casing bore.

15 The driven gear is mounted in the same manner as described in the proceeding paragraph for the idler gear.

16 The coupling shaft gear is carried in ball and roller bearings identical to those used for the idler and driven gears, the roller bearing being identical also to that used for the driving gear. The inner races are clamped on the gear by means of the coupling shaft (15) splined into the bore of the gear and secured by a shroud locking nut (22). The ball bearing outer race is stepped into the bore in the front casting and held in abutment with a circlip by a facing in a bolted housing (14) fitted with an oil seal. The spigot of a cover, identical to cover (55) locates the roller bearing outer race in the rear casing bore.

17 After the transfer gearbox has been bolted to the flywheel housing (Fig 1 (9)) a laminated flexplate is secured to the coupling shaft flange for transmitting the drive to the torque converter pump cover (Fig 5 (7)) of the Allison gearbox. The laminated flexplate comprises two plain flexible steel plates (Fig 6 (18)) and another (19) with three spot welded plate washers. These plates and two clamping rings (16) are located by a fouling pin (17) and secured in position by twelve setscrews.

18 The transfer gearbox is provided with disconnector mechanism at its input end to facilitate engine starting under extreme cold conditions.

19 The flywheel housing, both gearboxes and the propeller shaft are built with the engine on a sub-frame to form part of a power pack.

Dis-connector mechanism

20 The driving hub (Fig 3 (13)) of the engine coupling is received in a split thin-wall bush (Fig 6 (5)) pressed into the driving gear bore. Splined into this bore with a sliding fit is a coupling shaft (7) operated by a plunger (46) mounted in a ball bearing (48) and secured by a slotted nut. The bearing is retained in the shaft by a circlip. The plunger projects through the bore of the cover (55) fitted with an O ring seal (40) and pin-jointed to the plunger to the lower lever (30) pivoted by its shaft portion in two lugs on the cover. Clamped on the serrated end of the shaft is an upper lever (29) with a rod attached by a knuckle joint that connects with the dis-connector operating handle.

21 The coupling shaft is located in the driving gear by the engagement of a spring loaded detent ball (9) in either of two annular grooves, one corresponding to the driving position and the other to the disconnected position. The operating handle pivots from a welded bracket positioned on the power pack sub-frame. When the operating handle is lifted upward, it causes the disconnecter coupling shaft (7) to engage with the engine coupling driving hub (Fig 2 (9)). The engine must be stopped before connecting or disconnecting the drive.

Lubrication

22 The oil is fed from the engine scavenge oil way via a pipe (Fig 2 (4)) to a transfer tube assembly (3) bolted to the flywheel housing. The tube passes through a hole in the transfer gearbox front casing and connects with three inter-connected jets that provide spray lubrication to the transfer gear train.

23 The oil transfer tube (Fig 4 (7)) is mounted in the bore of its housing, and sealed by O-rings (5 and 6). The housing with integral feed pipe (10) is bolted to the flywheel housing (4), a supporting stud (2) screwed into the closed end of the tube passes through a reducing bore to fit into a hole drilled into the centre of a plug (1) screwed into the engine casing (3). Oil from the feed pipe flows into the tube bore through ports drilled in an annular groove machined in the tube body. The jet block (8) bolted to a bored hole in the front casing mates with the reduced end of the tube and is sealed by an O-ring (9), surplus oil fed via two tubes from this centre jet block is sprayed onto the teeth of the adjacent spur wheels by two jets that are also bolted to the front casing. Oil splash completes the lubrication to bearings, etc.

24 The pump mounted in the gearbox sump returns the drained oil to the engine sump via a connection orifice (Fig 2 (5)). With the drive disconnected and the engine running the oil is returned to the engine sump by a pipe provided from a union (Fig 6 (38)) positioned in the rear casing.

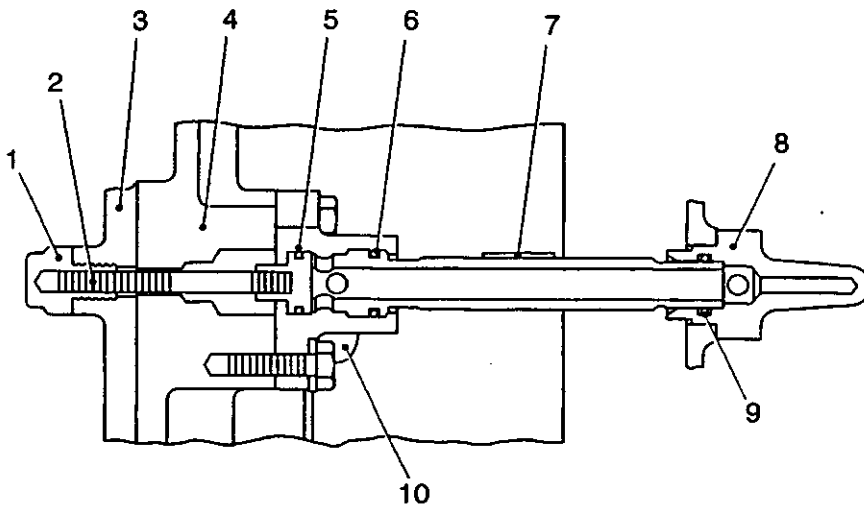

432/281

1	Plug	6	O ring
2	Stud	7	Tube
3	Engine casing	8	Jet block
4	Flywheel housing	9	O ring
5	O-ring	10	Pipe

Fig 4 Oil feed pipe

GEARBOX

25 The gearbox is an Allison Torqmatic Model TX 200-4A in earlier vehicles or a TX 200-4B in late vehicles. The Allison gearbox (Figs 5 and 7) is of the straight through, hydraulically operated, automatic type, all rotating drive components being in a straight line from the input to the output end. It incorporates a 3-element torque converter with automatic lock-up clutch, planetary gearing, speed range clutches and a hydraulic system. Four forward speed ranges (i.e. 1-2, 3-4, 3-5 and 3-6), and one reverse range manually selected. Automatic shifts occur in each forward range.

NOTE

Location terms used in describing the gearbox are front, rear right and left; these terms are used as for a gearbox of conventional unit construction with the engine. The front of the gearbox is the input or torque converter end and the rear is the output end. Right is towards the viewer's right when he/she is standing at the rear and facing the output end. All references to rotation are from this viewing point.

26 Power from the engine is transmitted through the transfer gearbox and laminated flexplate to the torque converter pump cover (Fig 5 (7)). The torque converter multiplies the torque with a maximum ratio of 2.8 to 1 at stall. The lock-up clutch automatically provides a direct drive to planetary gearing when the torque converter action is not needed.

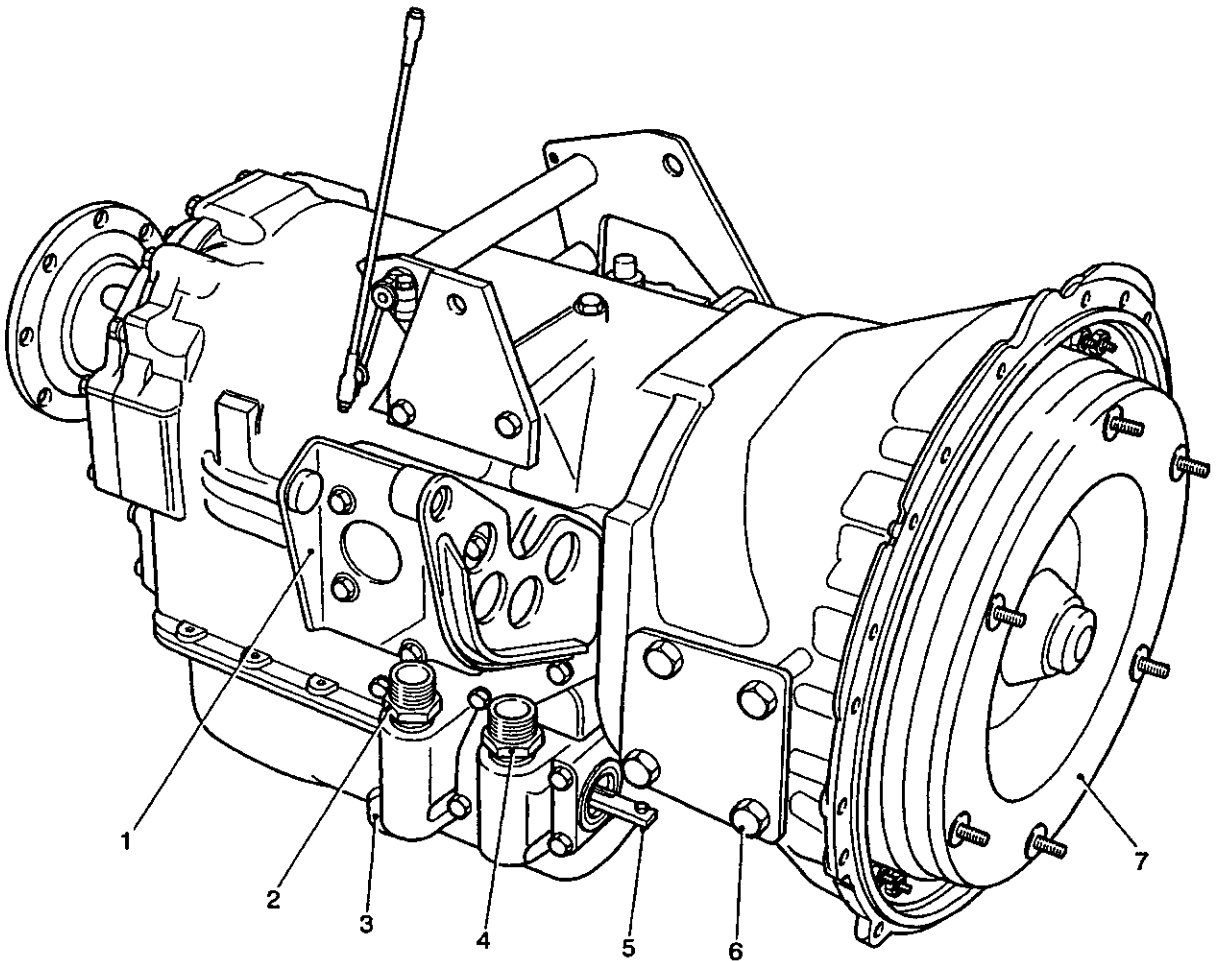

432/276

- | | | | |
|---|---|---|---------------------------------------|
| 1 | AC generator mounting bracket | 5 | Oil brake control valve (inoperative) |
| 2 | Adaptor (oil feed pipe to heat exchanger) | 6 | Mounting face plug (four) |
| 3 | Magnetic drain plug | 7 | Torque converter pump cover |
| 4 | Adaptor (oil feed pipe to heat exchanger) | | |

Fig 5 Three-quarter front view of Allison gearbox

KEY TO FIG 6

1	Oil pump driving gear	30	Lower lever
2	Oil seal and bearing housing	31	'O' sealing ring
3	Ball bearing	32	Bobbin
4	Shroud locking nut	33	Split pin
5	Bush	34	Gasket
6	Oil seal	35	Return tube
7	Dis-connector coupling shaft	36	'O' sealing ring
8	Spring	37	Gasket
9	Detent ball	38	Union, oil return
10	Shroud locking nut	39	Cover
11	Cover	40	'O' sealing ring
12	Ball bearing	41	Joint pin
13	Circlip	42	Rear casing
14	Oil seal and bearing housing	43	Roller bearing
15	Coupling shaft	44	Circlip
16	Clamping rings	45	Circlip
17	Fouling pin	46	Dis-connector plunger
18	Flexplate	47	Oil pump
19	Flexplate plate washer	48	Ball bearing
20	Coupling shaft gear	49	Driving rotor
21	Input driving gear	50	Cover
22	Shroud locking nut	51	Driven rotor
23	Left oil jet	52	Oil pump body
24	Centre oil jet	53	Suction strainer
25	Right oil jet	54	Adaptor
26	Driven gear	55	Cover
27	Idler gear	56	Gasket
28	Pump driven gear	57	Front casing
29	Upper level		
(a)	Gear train (schematic)		

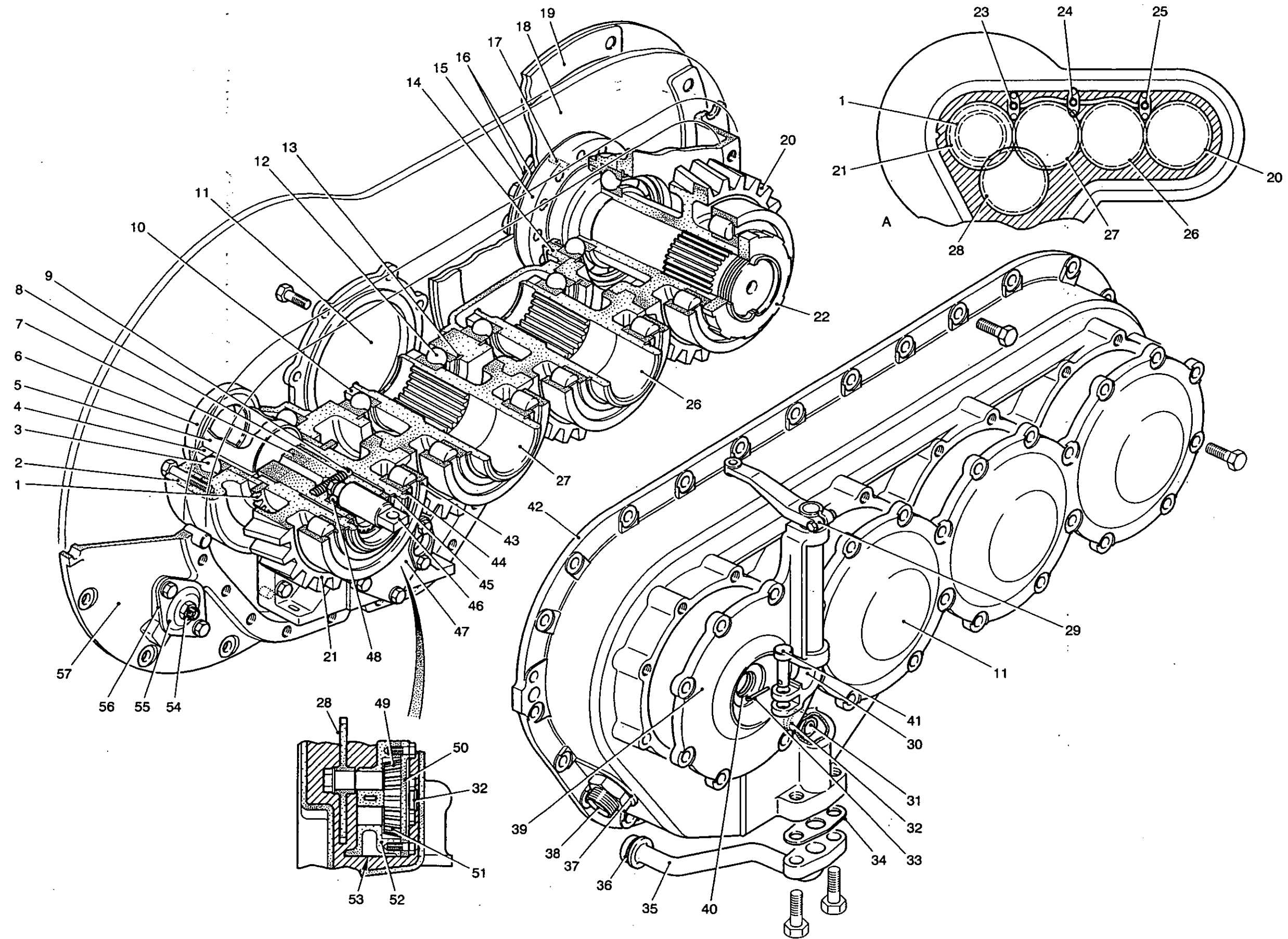
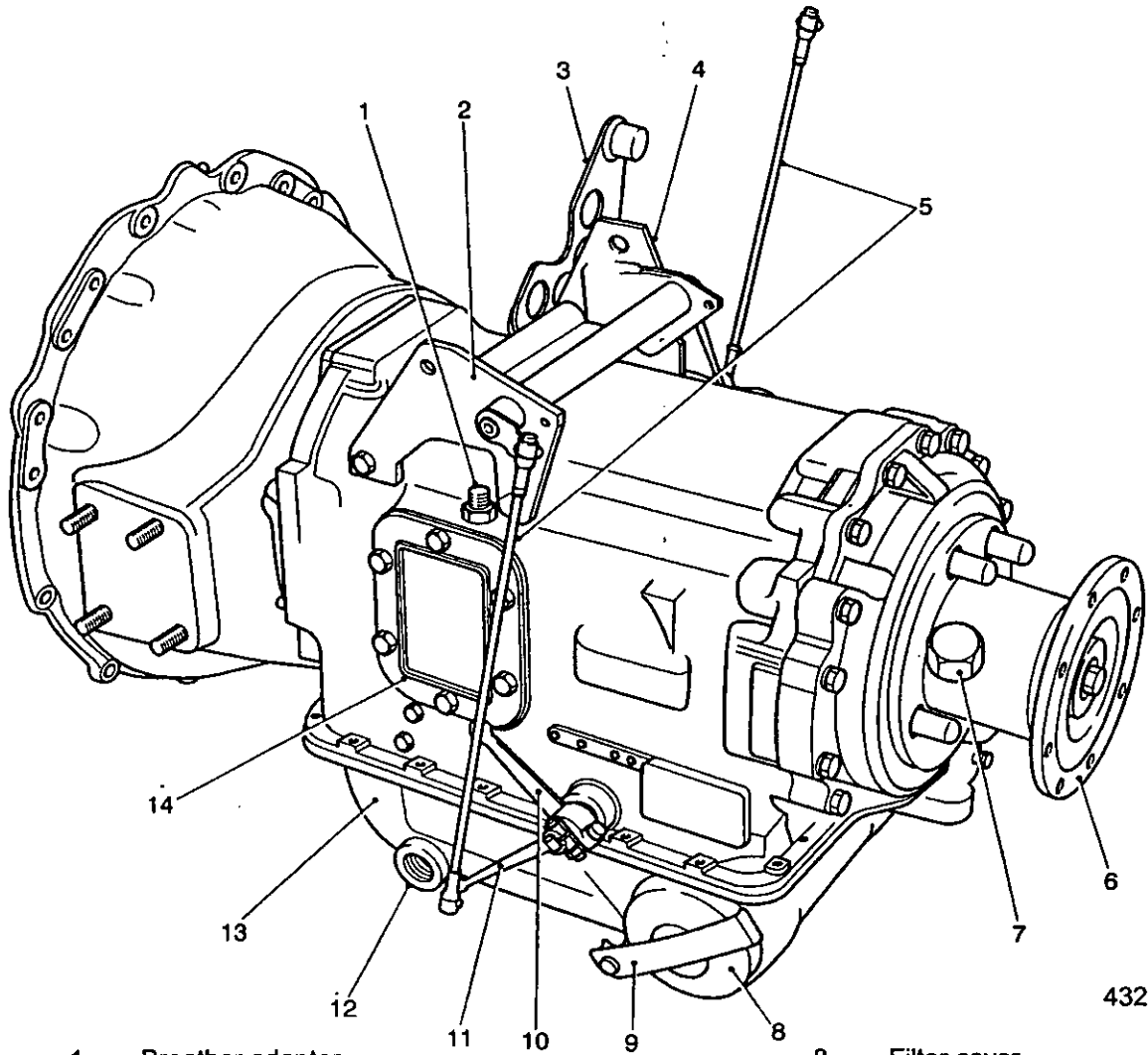

Fig 6 Transfer gearbox



432/279

- | | | | |
|---|-------------------------------|----|-----------------------|
| 1 | Breather adaptor | 8 | Filter cover |
| 2 | Bracket | 9 | Strap |
| 3 | AC generator mounting bracket | 10 | Manual selector lever |
| 4 | Bracket | 11 | Throttle valve lever |
| 5 | Throttle valve linkage | 12 | Filler orifice |
| 6 | Output coupling | 13 | Oil pan |
| 7 | Speedometer drive plug | 14 | Power take-off cover |

Fig 7 Three-quarter rear view of Allison gearbox

Torque converter

27 The torque converter is filled with oil at all times and the pump is driven by the engine through the transfer gearbox. The pump rotation is clockwise as viewed from the front or input end.

28 When the engine is turning, the blades of the pump impel the oil outward from the centre and across the outer blades of the turbine, striking them with such force that the turbine turns in the same direction as the pump.

29 While the pump (Fig 8 (3)) is rotating much faster than the turbine (2), the oil issues from the centre of the turbine and enters the stator (4) in a direction opposite to that in which the pump is rotating. The oil strikes the concave sides of the stator blades which cause the roller clutch to lock. The stator blades then re-direct the oil to the pump in the direction of the pump rotation and the energy remaining in the oil assists the engine in turning the pump. Under these conditions the converter multiplies torque.

30 When the turbine speed approaches about eight-tenths pump speed, the oil leaving the turbine is thrown more toward the direction of the pump rotation, as shown in (Fig 9), and tends to strike the convex sides of the blades. The roller clutch allows the stator to freewheel in the direction of pump rotation and the torque converter becomes a fluid coupling.

31 When the load increases, causing the turbine to slow down, torque multiplication begins again. If the turbine speed continues to slow down until it stops, the torque multiplication will then be at a maximum ratio of 2:80 to 1.

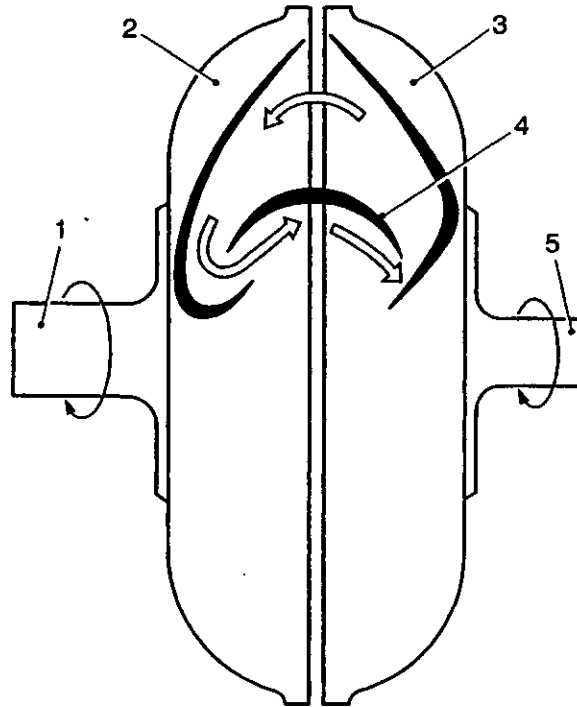

432/284

- | | | | |
|---|--------------|---|-------------|
| 1 | Output shaft | 4 | Stator |
| 2 | Turbine | 5 | Input shaft |
| 3 | Pump | | |

Fig 8 Torque converter operation - stator stationary

Lockup clutch

32 When the torque converter is in the fluid coupling phase and the turbine speed reaches approximately 0.85 times that of the pump, the lockup clutch engages to give a 1 to 1 mechanical drive with 100 per cent efficiency.

33 The lockup clutch is engaged by oil pressure according to throttle opening and turbine speed. At light throttle, the clutch engaged at low engine speed since the load requirements are low. At full throttle, the lockup clutch is engaged at a much higher speed to correspond to the heavier loads.

34 The lockup clutch momentarily disengages during each shift, manual and automatic, to cushion any possible shock loads. As soon as a shift is completed, the clutch is engaged again.

35 Oil pressure from the control valve body comes up through a passage in the turbine shaft, out at the end and through slots in the converter pump cover hub. The oil forces the piston rearward, sandwiching the clutch plate between the piston and backplate. This mechanically locks the pump to the turbine. When the oil pressure is relieved, the piston return spring reacts and unlocks the converter for hydraulic operation.

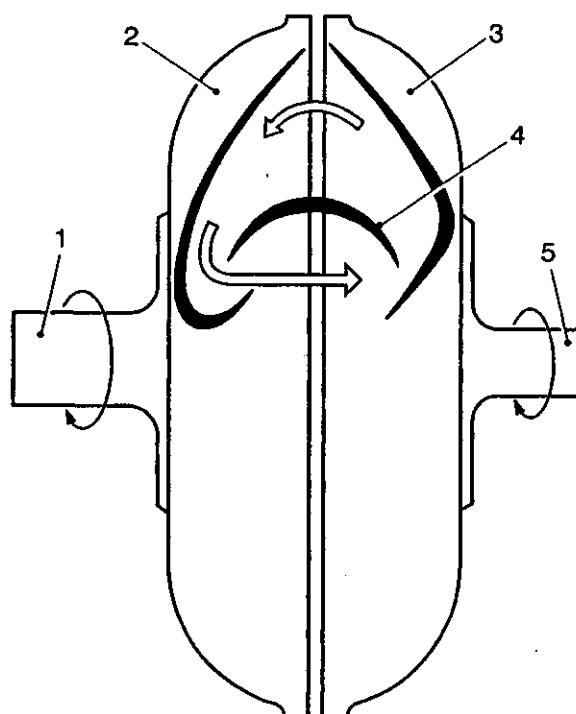

432/285

1	Output shaft	4	Stator
2	Turbine	5	Input shaft
3	Pump		

Fig 9 Torque converter operation - stator free wheeling

GEAR RANGE SELECTOR

36 The gear range selector and control rod are shown in Fig 10. The selector is located to the left of the driver and is secured to the engine compartment sill plate. Between the selector and the sill plate is a gasket (22), which is initially secured between the facings of the gate (23) and a case (8).

37 The case is formed with one compartment for the selector lever (6) and another for a micro switch (17) and striker lever (14). Secured on the outer sides of the compartments are a left cover plate (7), which is also dowelled, and a right cover plate (19). Case, gate and covers are made of aluminium alloy.

38 The forked lower end of the selector lever is carried on a pivot pin (9) secured by a Mills pin in a pivot (15) (this Mills pin is held in position using adhesive, the axes of the pivot pin and pivot being at 90 degrees to each other). Surrounding the pivot pin at one side of the pivot is a torsion spring (11), which applies pressure on the left side of the lever. The pivot is supported in two bushes (12) pressed one in the case and the other in the left cover plate. The bushes are of the dry type incorporating a fluorocarbon plastic (PTFE).

39 Pinned on a protruding end of the pivot is the striker lever that is formed at its upper end with a knife-edged striker for operating the micro switch through its lever (18) incorporating a roller (21). A retainer and two nuts secure the micro-switch to a carrier, which is bolted to the case.

40 A reverse stop is provided. It comprises a pin (2) with a collar (4) secured by a Mills pin and a knob (1) secured by a lock nut. There is also a spring (3), which lightly loads the stop.

41 The rear end of the control rod (16) is connected to the manual selector lever on the gearbox. The rod is adjusted to ensure that the gearbox lever is vertical when neutral is selected.

42 The gear range selector lever positions for selecting neutral (N), reverse (R), or any one of the four forward speed ranges (3-6, 3-5, 3-4, 1-2) are indicated in raised letters and numerals on the gate, as shown in Fig 10(b).

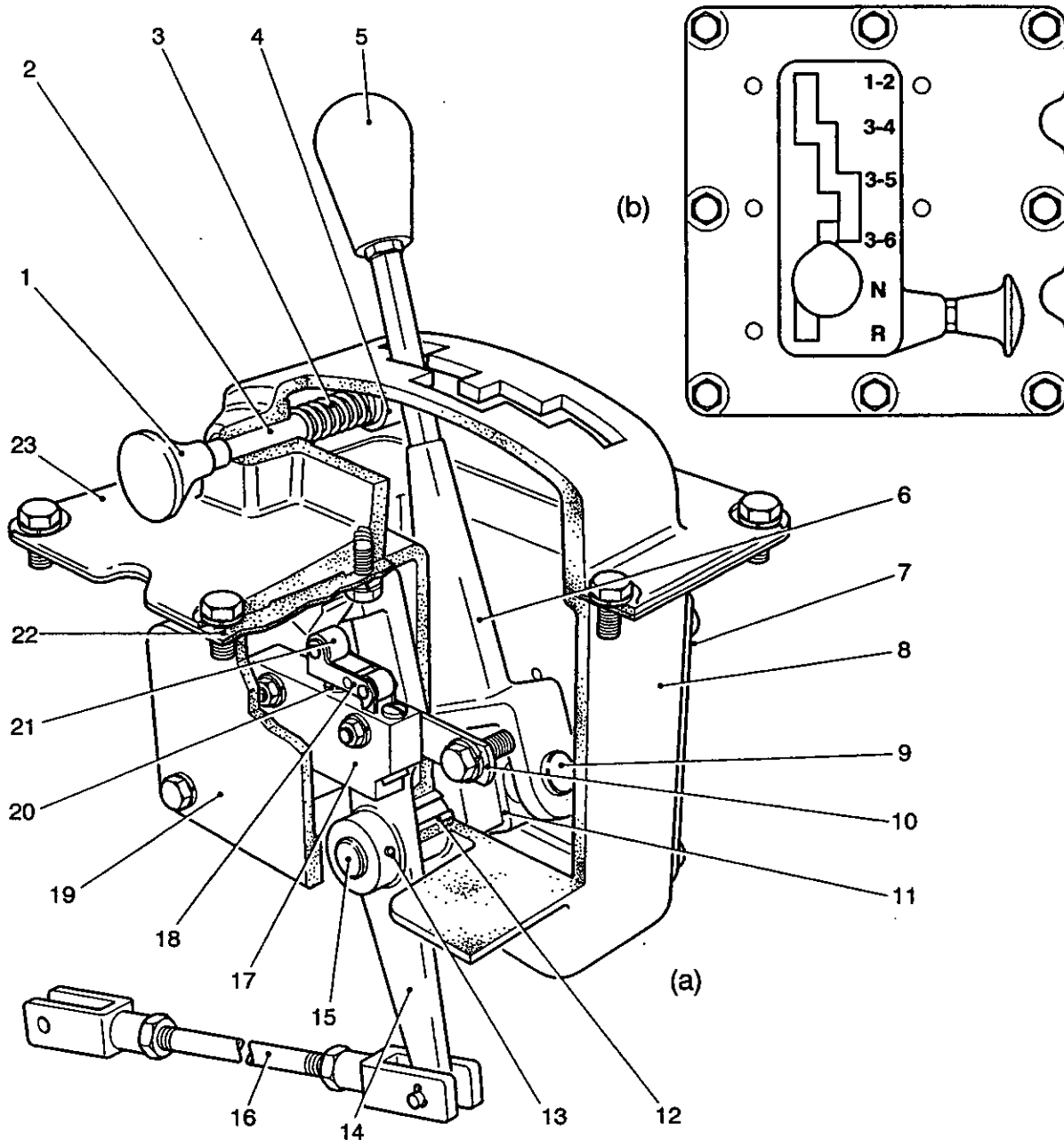

432/358a

- | | | | |
|----|-----------------------|----|--------------------|
| 1 | Reverse stop knob | 13 | Pin, spring steel |
| 2 | Reverse stop pin | 14 | Strike lever |
| 3 | Reverse stop spring | 15 | Pivot |
| 4 | Reverse stop collar | 16 | Control rod |
| 5 | Selector lever knob | 17 | Micro switch |
| 6 | Selector lever | 18 | Micro switch lever |
| 7 | Left cover plate | 19 | Right cover plate |
| 8 | Case | 20 | spring |
| 9 | Pivot pin | 21 | Roller |
| 10 | Micro switch carrier | 22 | Gasket |
| 11 | Selector lever spring | 23 | Gate |
| 12 | Bush | | |

(a) Three-quarter front broken view

(b) Plan view

Fig 10 Gear range selector

Operation

43 When the selector lever is placed by the driver up to the abutment in any slot in the gate, it causes the manual selector valve in the gearbox to be moved to a corresponding position in which it charges or exhausts the hydraulic lines as necessary. The selector lever is held in position by the torsion spring and the valve is held by two spring-loaded detent balls.

44 In order to engage the selector lever in the reverse slot it is necessary first to pull the stop to the right.

45 When the selector lever is in the neutral position, the striker on the striker lever depresses the micro switch lever causing the switch to make the starter motor circuit and break the stoplight and turn light circuit. In any other positions of the selector lever, the micro switch operates in the opposite manner.

PROPELLER SHAFT

46 The propeller shaft (Fig 11) transmits the drive from the gearbox to the steering unit. It consists of a double universal joint of which the inner yokes, one male and one female, form a welded assembly (7). Spigoted circular flanges are formed on the coupling yokes (1). The spiders (6) connecting the yokes are each carried in four needle roller bearings. Each joint is provided with a lubricating nipple (8) and a relief valve (9). No sliding joint is provided on the propeller shaft for longitudinal adjustment, as the steering unit coupling shaft, to which one coupling yoke is bolted, is slid able. The other coupling yoke is bolted to the gearbox output shaft flange. The steering unit must be brought into alignment with a fixed tolerance before the propeller shaft is coupled.

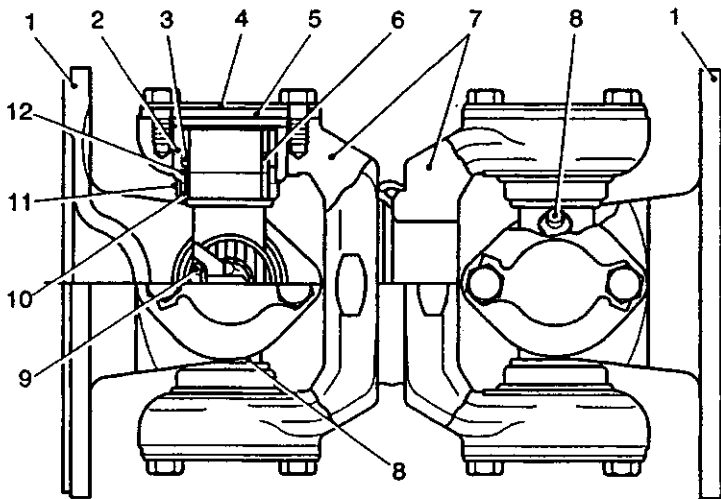

432/287

1	Flange yoke	7	Inner yoke assembly
2	Needle roller race	8	Lubricating nipple
3	Needle roller	9	Relief valve
4	Locking strap	10	Cork gasket
5	Bearing cap	11	Gasket retainer
6	Spider	12	Bearing seal

Fig 11 Propeller shaft

STEERING UNIT

47 The steering unit (Fig 12 and 13) is a controlled differential type S1 F6 Mk A. It consists of spur type differential gears controlled through additional planetary gears by either of a pair of manually operated external contracting brakes. The steering ratio is 1:78 to 1. The steering brakes are operated simultaneously for slowing or stopping the vehicle and held ON by pawl and ratchet mechanism when parking. Since there are no independent vehicle brakes, the steering unit does not permit skid steering. An input spiral bevel pinion and mating wheel give a reduction ratio of 2:07 to 1. Lubrication of all parts is effected by an oil bath in combination with a dry sump pressure feed system.

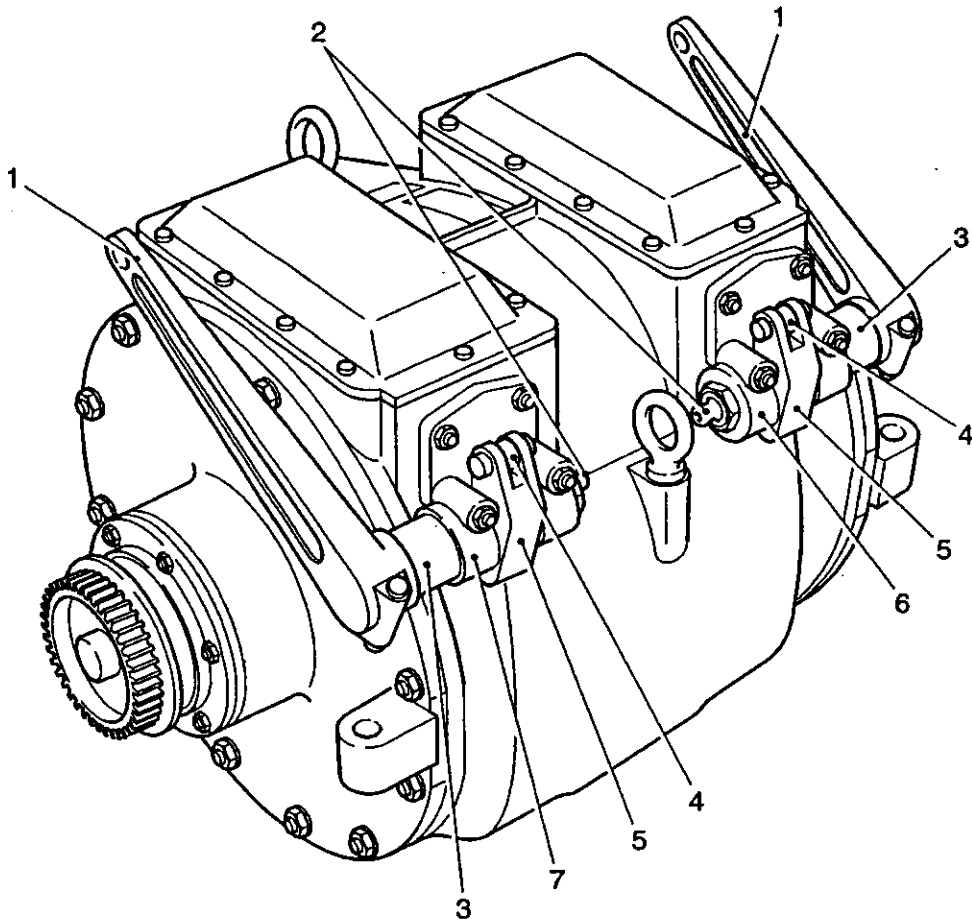

432/277

- | | | | |
|---|-----------------------|---|-----------------------------|
| 1 | Brake operating lever | 5 | Fork |
| 2 | Lubricating nipple | 6 | Left operating pin housing |
| 3 | Shaft | 7 | Right operating pin housing |
| 4 | Roller | | |

Fig 12 Three-quarter front view of steering unit

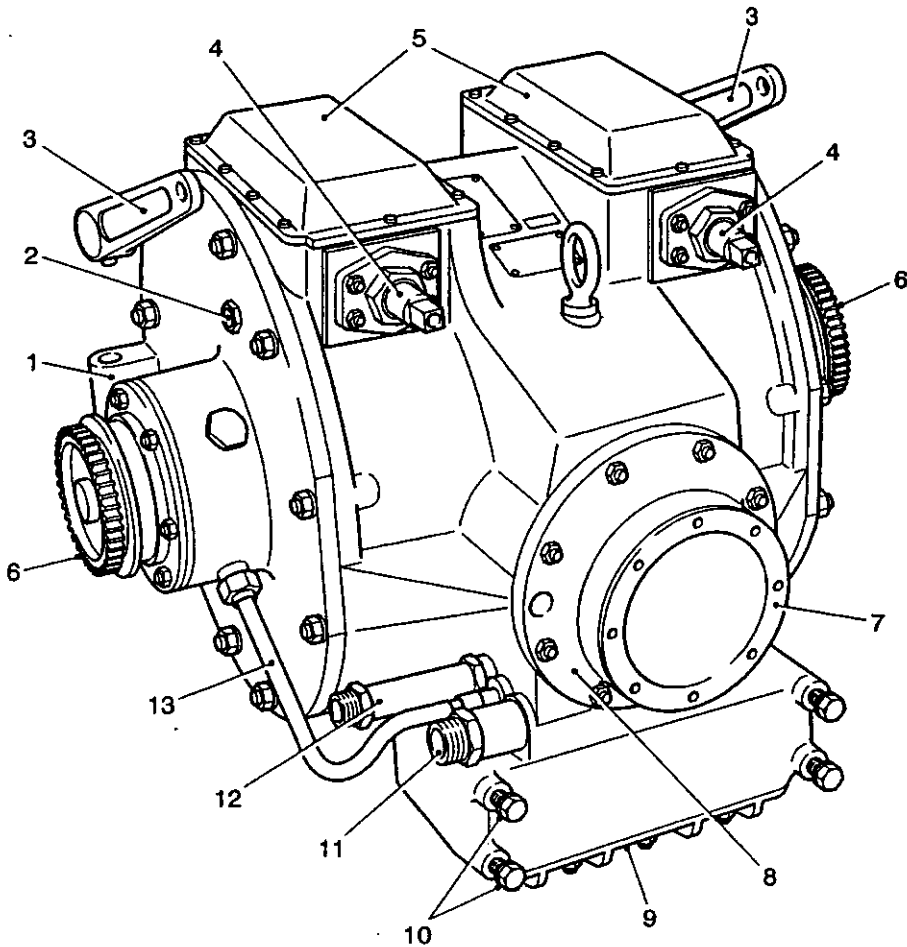

432/278

- | | | | |
|---|---------------------------|----|---------------------------------------|
| 1 | Mounting lug on end cover | 8 | Input bearing housing |
| 2 | Breather unit | 9 | Sump |
| 3 | Brake operating lever | 10 | Mounting studs |
| 4 | Brake adjusting screw | 11 | Union for tank feed hose to pump |
| 5 | Brake mechanism screw | 12 | Union for feed pipe to heat exchanger |
| 6 | Output flange | 13 | Oil supply pipe to differential |
| 7 | Coupling shaft | | |

Fig 13 Three-quarter rear view of steering unit

Differential assembly

48 The differential gears are supported in a casing consisting of left and right flanges (Fig 14 (9)) and (14)) and a spacer (12). Each flange is formed with a tubular shaft portion and the spacer is formed with three arms radiating from a central hub. Fitted on the right flange is a spiral bevel wheel (18), which is located together with the flange on the spacer arms by three shear pins (Fig 15 (8)). Three short bolts (9) secure the bevel wheel to the right flange and three long through bolts (6) secure both parts and the spacer to the left flange. This flange in turn is located on the spacer arms by three shear pins (Fig 16 (1)) and secured in position by three through bolts (2) screwed into the right flange.

49 The differential gears comprise six planet gears (Fig 14 (13)) and (Fig 16 (9)) arranged alternately to form three pairs meshed at the centre with the teeth of one of each pair overlapping at the left and the teeth of the other overlapping at the right. Each planet gear is formed with an integral shaft having a plain end and a splined and screw-threaded end. The plain end is carried in a plain phosphor bronze bush (Fig 14 (7)) while the splined end, protrudes through a flanged bush (16) to receive a pinion (4), which is secured by a nut locked by a washer. Between the planet gear and flanged bush is fitted a casehardened steel thrust washer (15) and on the protruding outer end of the bush is fitted a phosphor bronze washer (17). Each bush is secured in position by a locking screw (72).

50 Meshed with each group of planet gears, three at the left and three at the right, is an output shaft pinion (sun gear) (42) supported in two flanged phosphor bronze bushes (39) and 41) fitted respectively to the differential flange and the flange spacer. Each group of planet pinions is similarly meshed with a sun gear formed integrally with a brake drum hub (36) carried by a thin wall split bush (78) on the shaft portion of the differential flange.

51 At the inner side of each brake drum hub is fitted a bearing washer (80), which is chamfered to clear a fillet on the shaft, and at the outer side is fitted a flat washer (19), both washers being made of phosphor bronze. A brake drum (37) is secured to each hub by eight fitted bolts with nuts locked in pairs by four washer plates. Three jet pipes (38) and (Fig 15 (4)) are fitted to spray oil on the side of the right drum, which is screened by the bevel wheel.

52 The differential assembly is supported in the steering unit housing (Fig 14 (61)) by a double row ball bearing (33) in conjunction with a bearing housing (28) and end cover (22) at the right and by a roller bearing (73) in conjunction with a bearing housing (75) and end cover (74) at the left. The inner race of each bearing is held in abutment with a case-hardened steel spacing washer (34) by an external circlip (32) while the outer race is retained in the bearing housing by an internal circlip (35). The differential assembly is adjusted laterally for correct meshing of the bevel wheel with the pinion by inserting two shims (23) of the required total thickness between the bearing housing flange and end cover at one side or the other.

53 The steering unit housing and end covers are made of aluminium alloy and the bearing housings of malleable cast iron. The left bearing housing is fitted with a split thin wall bush (77) having an oil hole aligned with another in the housing for directing oil pressure feed to the output shafts. The right bearing housing is stamped TOP on the periphery of its flange to ensure the correct alignment of a central radial oil hole with another in the end cover.

54 Each output shaft (76) and (29) is splined at its inner end through a pinion in which position an oil jet (10) pressed in the left shaft protrudes through the collar (11) pressed in the other. Splined on the outer end of each shaft, and secured by a thick washer, slotted nut and split pin, is a gear type-coupling flange (24) supported in a ball bearing. The inner race of the bearing is held between a shoulder on the coupling and a splined collar on the shaft, while the outer race is held up to an abutment in the bearing housing by a spigot of an oil seal housing (31). Each coupling flange is fitted with an O sealing ring (25), located by a spring clip (26), and two semi-circular coupling retaining plates (27), secured by setscrews locked in pairs by tab washers.

KEY TO FIG 12

1	Operating lever shaft	44	Input bearing housing
2	Brake operating lever	45	O sealing ring
3	Left operating pin housing	46	Bearing retaining nut
4	Planet pinion	47	Oil seal housing
5	Operating fork	48	Steering unit coupling shaft
6	Roller	49	Oil pump
7	Bush	50	Oil pump stud
8	Guide plate	51	Sump drain plug
9	Left differential	52	Set screw securing oil strainer and upper joint to pump
10	Oil jet	53	Sump
11	Collar	54	Oil drilling plug
12	Differential flange spacer	55	Oil seal
13	Planet gear	56	Upper joint
14	Right differential flange	57	Oil strainer
15	Thrust washer	58	Lower joint
16	Bush	59	Bearing adjusting washers (2)
17	Bush washer	60	Bearing housing adjusting washers (2)
18	Bevel wheel	61	Steering unit housing
19	Bearing washer	62	Union for feed hose to pump
20	Brake mechanism cover	63	Mounting stud
21	Joint	64	Pump drive gear
22	Right end cover	65	Pump gear oil jet
23	Bearing housing shims	66	Union for feed pipe to heat exchanger
24	Output flange	67	Oil supply pipe to differential
25	O sealing ring	68	Plugs
26	Spring clip	69	Washer
27	Retaining plate	70	Steering unit housing drain plug
28	Right bearing housing	71	Input bevel pinion
29	Right output shaft	72	Locking screw
30	Oil seal	73	Roller bearing
31	Oil seal housing	74	Left end cover
32	External circlip	75	Left bearing housing
33	Double row ball bearing	76	Left output shaft
34	Spacing washer	77	Bush
35	Internal circlip	78	Bush
36	Brake drum hub	79	Breather pipe union
37	Brake drum	80	Bearing washer
38	Oil jet pipe		
39	Bush		
40	Brake band		
41	Bush		
42	Output shaft pinions	A	Longitudinal oil channel
43	External circlip	B	Rear transverse oil channel

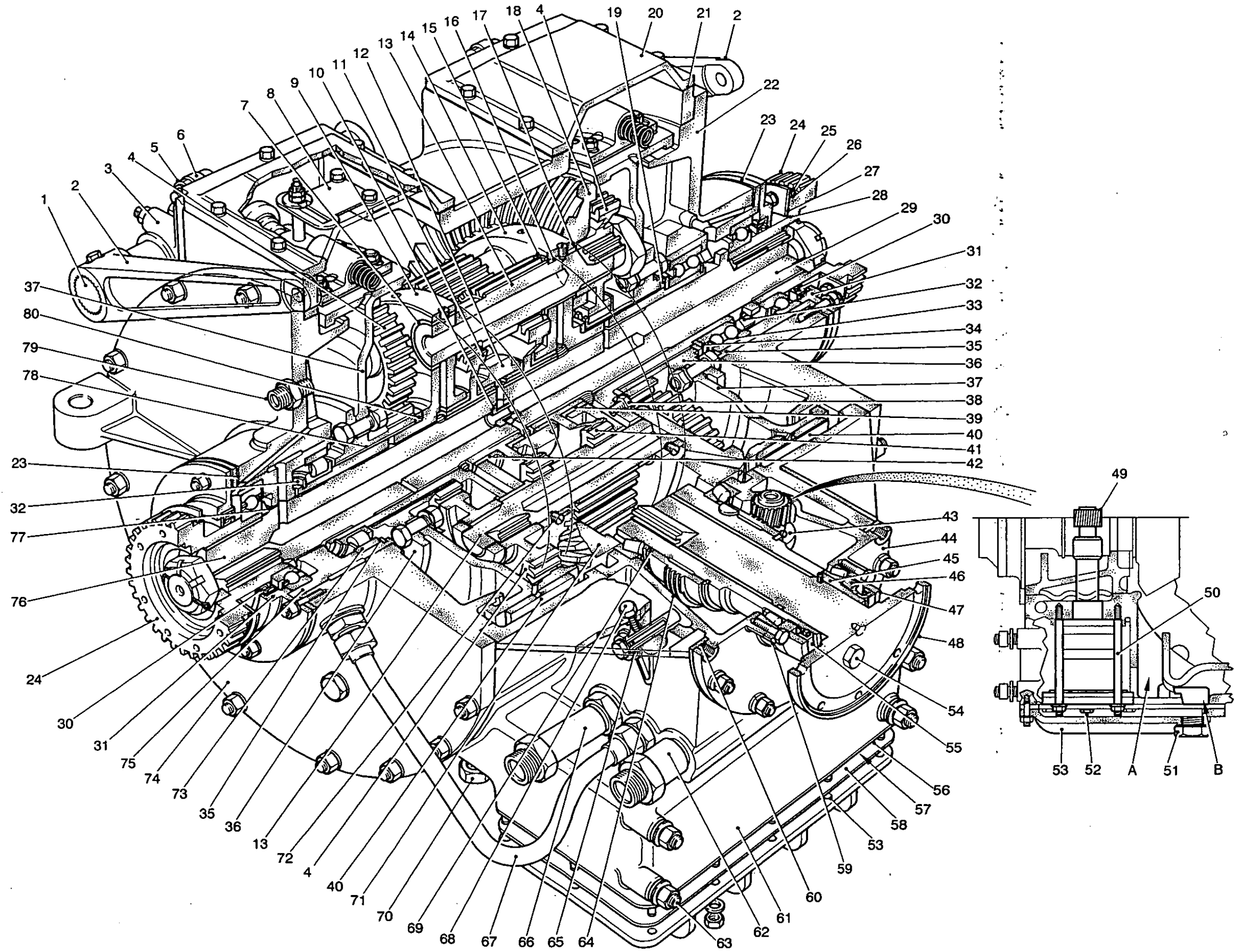
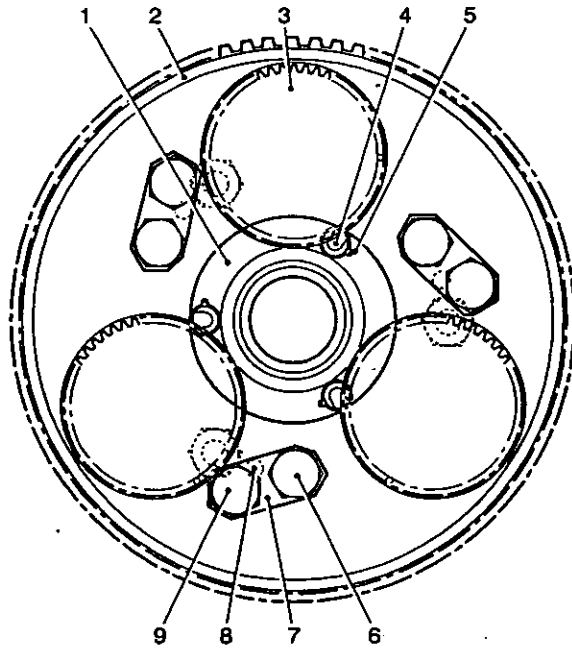

Fig 14 Broken perspective view of steering unit

432/422



423/359

- | | | | |
|---|---------------------------|---|---------------|
| 1 | Right differential flange | 6 | Fitted bolt |
| 2 | Spiral bevel wheel | 7 | Locking plate |
| 3 | Planet pinion | 8 | Shear pin |
| 4 | Oil jet pipe | 9 | Fitted bolt |
| 5 | Tab washer | | |

Fig 15 Securing bolts at bevel wheel side of differential

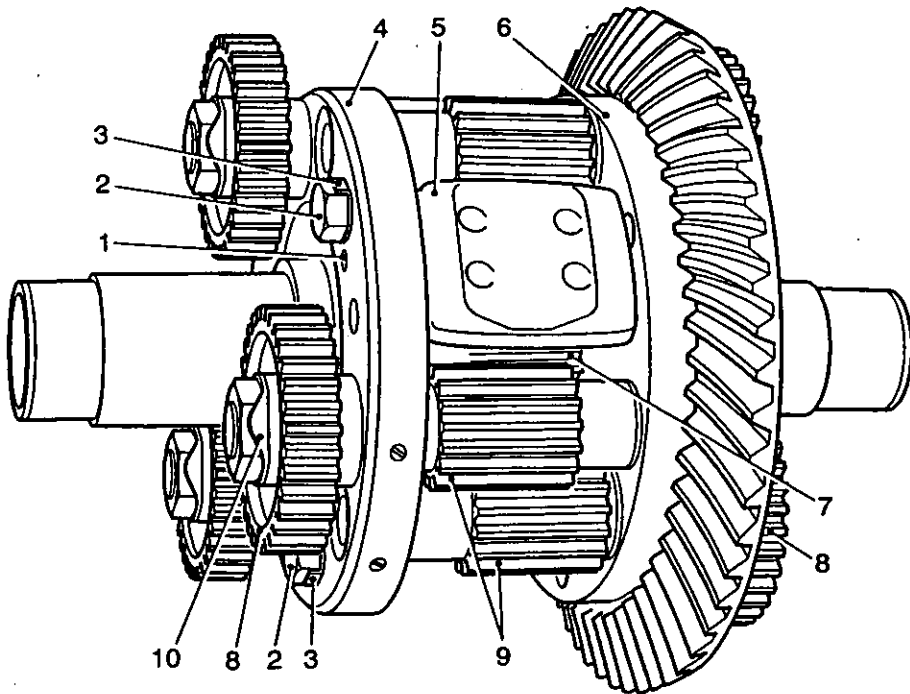

432/295

- | | | | |
|---|--------------------------|----|---------------------------|
| 1 | Shear pin | 6 | Right differential flange |
| 2 | Bolt | 7 | Output shaft pinion |
| 3 | Tab washer | 8 | Planet pinion |
| 4 | Left differential flange | 9 | Planet gears |
| 5 | Spacer | 10 | Locking washer |

Fig 16 Steering unit differential assembly

Input bevel pinion

55 The input bevel pinion (Fig 14 (71)) is supported in a cast iron housing (44) by two taper roller bearings of unequal size. Spaced by a washer (69) behind the inner cone of the large front bearing is a pump drive spiral gear (64), which is keyed to the pinion shaft portion and is retained in position by a circlip (43). The inner cone of the small rear bearing, with two adjusting washers (59) of suitable thickness at its inner side, is secured on the pinion shaft by a ring nut (46) formed with a locking sleeve, which is punched at one point into a slot provided in the shaft. An oil seal (55) is fitted to an aluminium alloy housing (47) bolted on the outer end of the bearing housing.

56 The input bevel pinion assembly is mounted in the bore provided in the rear of the steering unit housing. Between this housing and the bearing-housing flange are inserted two adjusting washers (60) of the required total thickness for correct meshing of the pinion with the bevel wheel. A coupling shaft (48), fitted with an O sealing ring (45), is splined into the inner end of the bore in the pinion. Finally, an oil jet (65) for lubrication of the pump drive gear is screwed into the steering unit housing. The inner end of the jet projects through hole in the pinion bearing housing.

NOTES

(1) Early steering units incorporate a steering unit housing having a blanking plate fitted in the outlet from channel A (Fig 14). An oil jet with a 3.2mm (0.125 in.) dia spray hole is fitted in conjunction with the pinion bearing housing.

(2) Later steering units with No. 5 erased from the modification record plate incorporate a steering unit housing with the outlet from channel A blanked off, as cast. The pinion bearing housing is modified by the addition of a 1.6mm (0.06 in.) dia oil spray hole in the land adjacent to the flange. The oil jet has a 2.5mm (0.1 in.) dia spray hole.

Brake mechanism

57 Each brake drum, one at the left and the other at the right of the differential assembly, is surrounded by a brake band (Fig 14 (40)), which is suspended at each end from a guide plate (8) secured to the steering unit housing. Each brake band is operated by one of two steering levers located in front of the driver's position and connected by mechanical linkage to two operating levers (2). For the steering levers and linkage, refer to Para 81.

58 Each operating lever is clamped on the serrated outer end of the shaft (1) supported in two lugs of a handed operating pin housing (3) secured to the steering unit housing. Clamped on a serrated portion of the shaft located between the pin housing lugs is a fork (5) carrying a roller (6), which bears on an operating pin (Fig 17 (2)).

59 Two lubricating nipples (Fig 12 (2)) and adaptors are fitted, one each to the inner end of each operating shaft. Drillings in the shafts connect the nipples and adaptors to the shaft bearings in the operating pin housings.

60 Each brake band comprises a spring steel band (Fig 17 (18)) with two end plates (20) each secured by seven steel rivets (23). Secured by tubular brass rivets is an asbestos based friction lining consisting of two end sections (21), thirteen left sections (27) and thirteen right sections (28). The left and right sections provide together a chevron pattern of oil grooves with the apices pointing in the opposite direction to that of the drum rotation (A). Before the end sections are riveted, four square-necked bolts are fitted to each of the band. These bolts and special nuts (19) secure two saddles (10), the nuts being locked by means of wire.

61 The slotted outer ends of the front and rear saddles receive respectively the operating pin (2) and the adjusting screw (15) and are held in abutment with them by the pressure of a long spring (11). Fitted to the operating pin housing is a lipped type oil seal ring (3).

62 Each brake band is suspended from the steering unit housing by means of two studs (8) screwed one into each saddle; modified studs are additionally locked in position by a nut. Each stud is fitted with a slider (7), which engages in a slot in the spring steel guide plate (9) and is held by two nuts locked together.

Brake adjustment

63 Each brake band is first set for running clearance by means of the adjusting screw. This is screwed into position until the operating pin protrudes a measured amount beyond the outer face of its housing. The guide plate sliders are then adjusted into position on the saddle studs by means of the nuts.

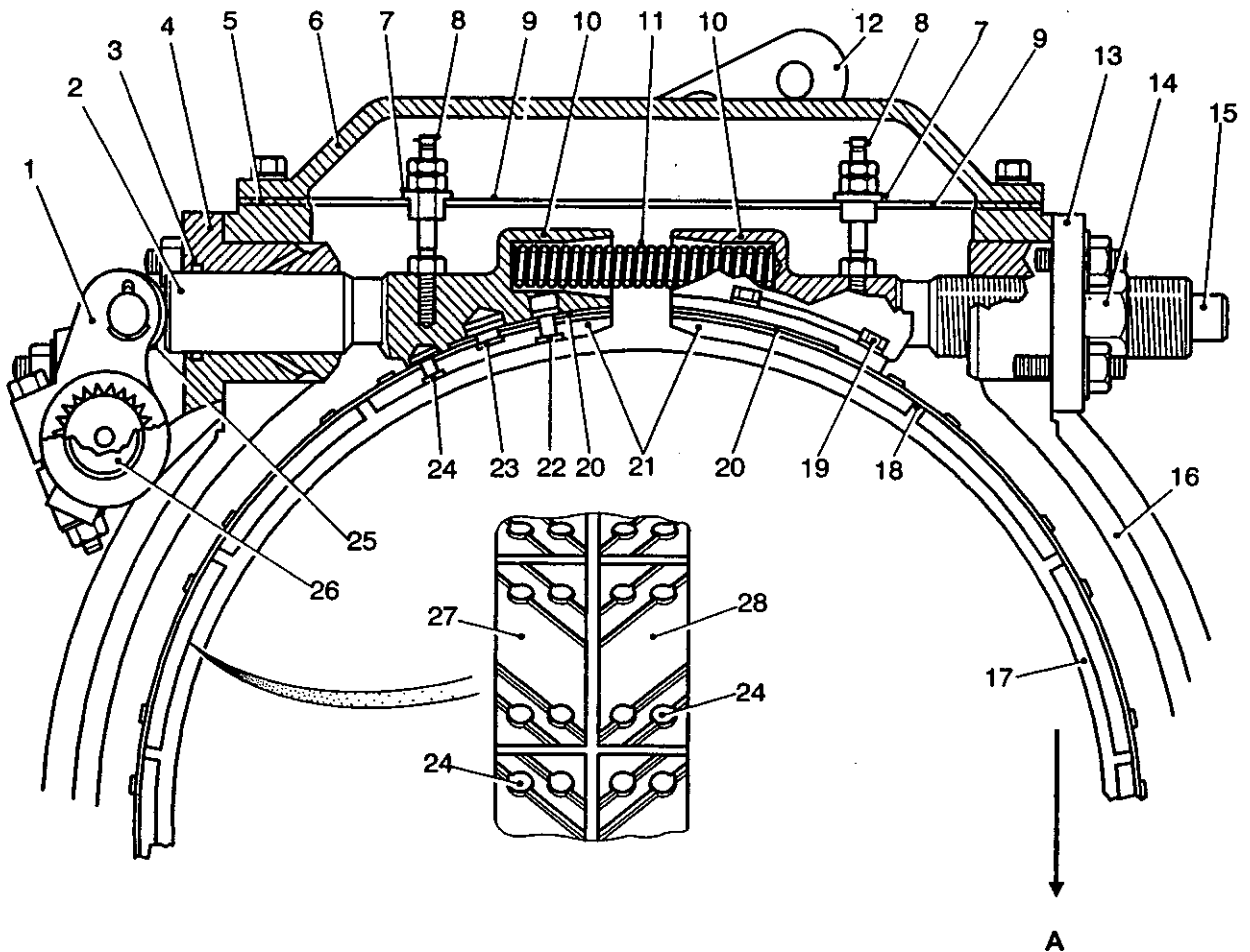

432/288

1	Operating fork	15	Adjusting screw
2	Operating pin	16	Steering unit housing
3	Oil seal ring	17	Brake drum
4	Right operating pin housing	18	Brake band
5	Joint	19	Saddle bolt nut
6	Cover	20	Brake lining end section
7	Slider	21	Brake lining end section
8	Stud	22	Brass rivet
9	Guide plate	23	Steel rivet
10	Saddle	24	Brass rivet
11	Spring	25	Roller
12	Operating lever	26	Operating shaft
13	Adjusting screw housing	27	Brake lining left section
14	Nut	28	Brake lining right section

A Direction of brake drum rotation

Fig 17 Brake mechanism

Lubrication system

64 Lubrication is effected by means of an oil bath in combination with a dry sump pressure feed system. The oil bath is formed in the bottom of the steering unit housing and oil picked up by the rotating differential bevel wheel, lubricates the input bevel pinion directly and certain exposed parts by splash. The brake bands and drums also dip into the oil bath and are thereby cooled. The dry sump system comprises a pump driven by the input pinion through spiral gears. The pump consists of two pumps, upper and lower, each a variant of the vane type. The upper or pressure pump draws oil from a tank and delivers it to the output shafts of the differential assembly where it is dispersed through various bearings. The lower or scavenge pump returns the oil from the sump to the tank through a section of the heat exchanger incorporated in the power pack.

65 The oil pump (Fig 14 (49)) is fitted with a gasket and secured in the steering unit housing by means of two studs (50). Attached to the bottom facing of the pump is a wire gauze strainer (57) and an upper joint (56), which are secured together with a lower joint (58) between the facings of the housing and a sump (53).

66 The component parts of the pump are shown in Fig 18. The upper pump comprises a upper pump housing (20) bored eccentrically to receive two blades (7) fitted with three interposed springs (8) to the slotted end of a shaft (6) mounted in a top plate (2) and fitted with a driving pinion (3). Similarly, the lower pump comprises a housing (17), two blades (10), four interposed springs and a short shaft (11), which is mounted in a spacer (19) and a cover (15) and is driven through a key (9) by the upper shaft.

67 The oil pump is driven in an anti-clockwise direction as seen from above when the gearbox is in forward drive. The action of the lower pump is similar to that of the upper pump. While the blades are being rotated, spring pressure keeps their rounded ends in contact with the wall of the bore, which, being eccentric causes the blades to slide in the slot in the shaft. At the same time the bore is divided by the blades into a suction chamber and a delivery chamber. This pumping action is shown in Fig 19.

68 The upper pump draws oil from the tank (Fig 20) via a hose (13) and union (Fig 14 (62)) and delivers it through a supply pipe (67) to a radial hole in a left bearing housing (75) and bush (77). The oil is then fed to axial holes in the output shafts (76) and (29) and redirected through other drilled passages shown in Fig 14 to lubricate all the remaining bushes in the differential assembly and eventually the ball and roller bearings and gearing. Three jet pipes (38) direct a supply of oil onto the right brake drum, which is shielded by the bevel wheel. A jet (65) sprays oil on the pump drive gear (64). In later steering units with No. 5 erased from the modification record plate, oil is also directed onto the rear end of the input bevel pinion shaft through a 1/16in. dia hole in the pinion housing (refer to Note (2) Para 56).

69 The oil bath is formed above and at each side of a longitudinal oil channel A (Fig 19) cast in the bottom of the steering unit housing. This channel runs between a front transverse channel and a similar rear channel B (Fig 19). A fabricated blanking plate is fitted in the outlet at the rear end of channel A in the housings of early steering units so increasing the amount of oil returning into the oil bath and preventing over-heating of the brake bands and drums. Later steering units with No. 5 erased from the modification record plate incorporate housings with a cast-in division blanking off the outlet from channel A (Fig 19). A Welch washer is fitted in the division.

70 The lower pump draws oil returned to the sump through the oil bath and channel B (Fig 19) and delivers it through passages in the pump and steering unit housing to a union (66) and heat exchanger feed pipe (Fig 20 (3)).

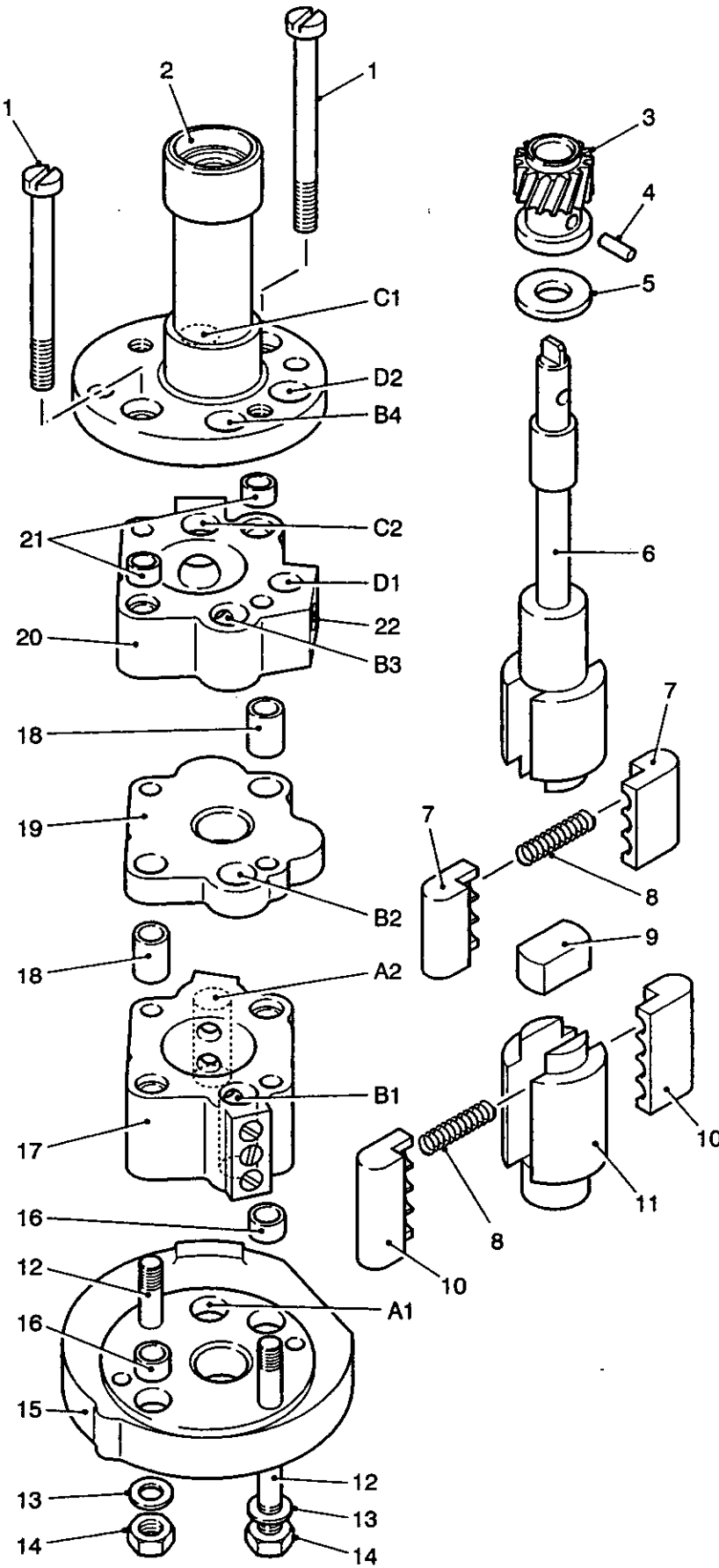

- 1 Bolt
- 2 Top plate
- 3 Driving pinion
- 4 Mills pin
- 5 Bearing washer (selective)
- 6 Upper shaft
- 7 Upper pump blade
- 8 Springs
- 9 Driving key
- 10 Lower pump blade
- 11 Lower shaft
- 12 Stud (fitted to top plate)
- 13 Washer
- 14 Nut
- 15 Cover
- 16 Dowel tube
- 17 Lower pump housing
- 18 Dowel tube
- 19 Housing spacer
- 20 Upper pump housing
- 21 Dowel tube
- 22 Oil drilling plug

- A1, A2, Lower pump suction passages
- B1, B2, B3, B4 Lower pump delivery passages
- C1, C2 Upper pump suction passages
- D1, D2 Upper pump delivery passages

432/291

Fig 18 Steering unit oil pump - exploded view

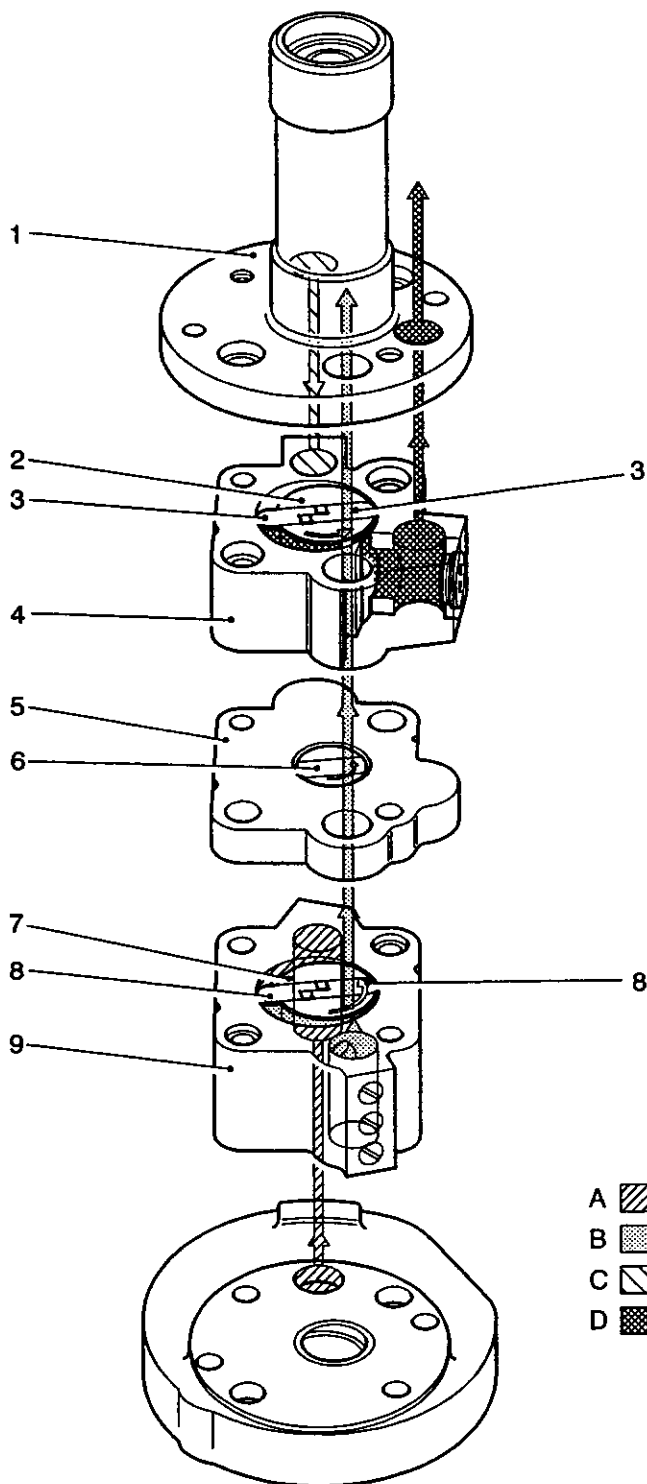

- 1 Top plate key
- Upper shaft
- 3 Upper pump blade
- 4 Upper pump housing
- 5 Housing spacer
- 6 Driving
- 7 Lower shaft
- 8 Lower pump blade
- 9 Lower pump housing
- 10 Cover

- A Lower pump suction
- B Lower pump delivery
- C Upper pump suction
- D Upper pump delivery

432/290

Fig 19 Operation of steering unit oil pump

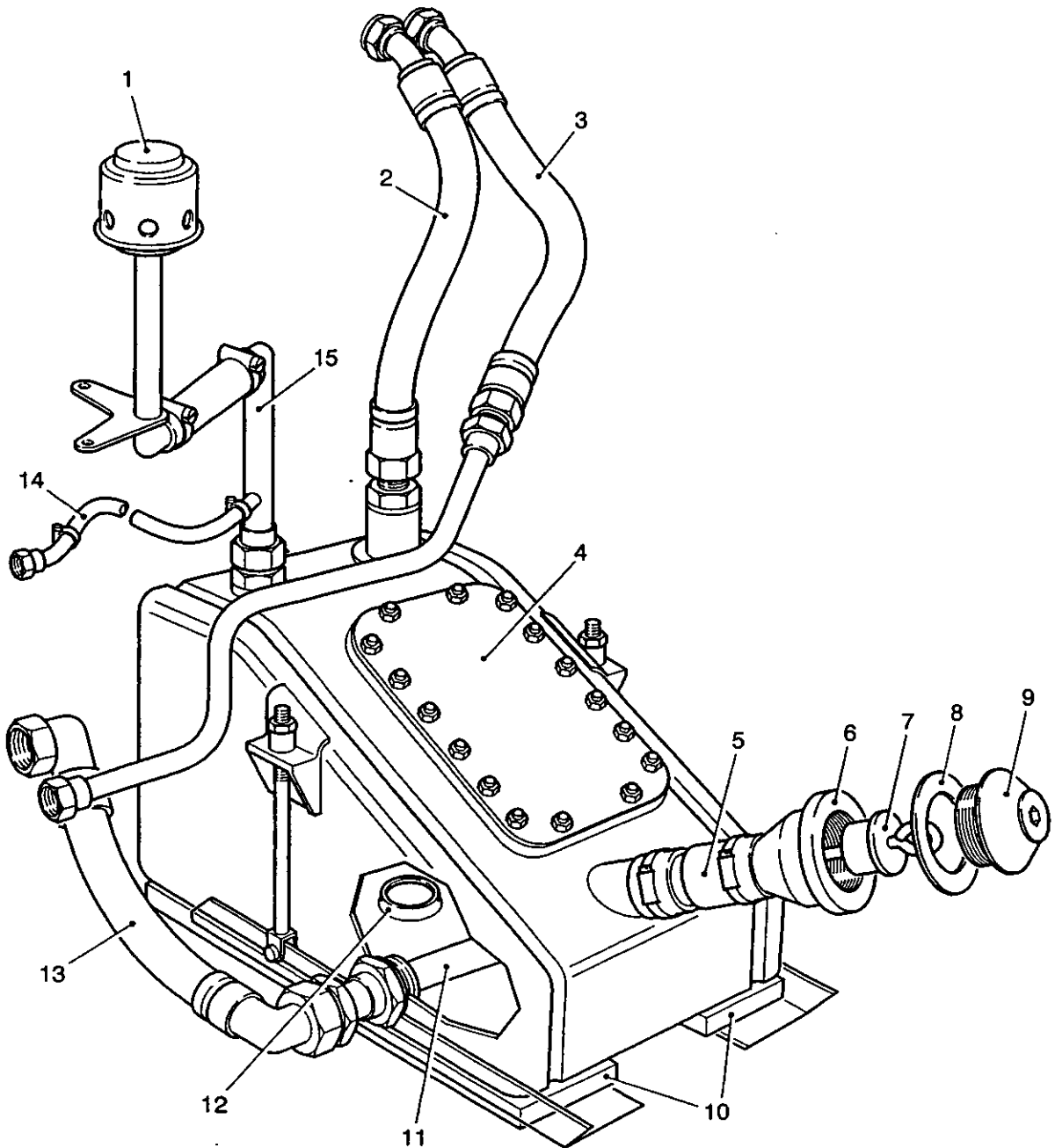

432/291

- | | | | |
|---|---------------------------------|----|---------------------------------|
| 1 | Breather air cleaner | 9 | Filler cap |
| 2 | Return pipe from heat exchanger | 10 | Felt pads |
| 3 | Feed pipe to heat exchanger | 11 | Gauze strainer |
| 4 | Cover plate | 12 | Drain plug |
| 5 | Long hose | 13 | Feed hose to steering unit pump |
| 6 | Filler cap adaptor | 14 | Steering unit breather pipe |
| 7 | Dipstick | 15 | Breather pipe |
| 8 | Seal washer | | |

Fig 20 Steering unit oil tank

Operation

71 When the gearbox is in forward drive, the input bevel pinion is driven in a clockwise direction as viewed from the rear. If neither brake band is applied the differential assembly is driven as one mass in a clockwise direction as viewed from the left with the result that the vehicle is driven straight forward.

Mounting

72 The steering unit is secured at the front by two bolts passing through two bosses formed one on each end cover (Fig 14 (74) and (22)). The bolts are secured into two-handed mounting brackets, which are bolted to other brackets welded on the hull lower front sloping plate.

73 A rear-mounting bracket, which is secured on studs (63) provided with the steering unit, is secured in turn by a single bolt onto a pad welded on the hull bottom plate.

74 Steel shims are fitted as required in front of the front mounting brackets and washers are fitted under the end cover bosses and under the rear bracket. Shims and washers are provided in thickness of 10 SWG (0.128in.) and 20 SWG (0.036in.).

Oil tank, pipes and fittings

75 The oil tank (Fig 20) is located to the left of the steering unit. It is mounted on two felt pads (10) between two longitudinal angles welded to the floor structure and is secured by long nuts fitted to two tie rods pinned to the angles.

76 The tank body is of fabricated steel construction and comprises a filler pipe, a short return tube and a number of tapped bosses for connecting pipes and a drain plug; welded to the return tube is an oil spreader with its outlet located just above the sloping plate of a de-frothing tray in front of which is a perforated baffle. A cover plate (4) is secured together with a gasket over a large aperture provided for cleaning purposes. The drain plug (12) is sealed by a copper washer.

77 The tank filler pipe is connected to a hose (5) and secured by hopes clips to the filler cap adaptor (6) welded to a machined hole in the glacis plate. The dipstick (7), with filler plug attached is seated in the adaptor, and a domed filler cap (9) with seal washer (8) screwed into the neck of the adaptor prevents the ingress of dust and moisture.

78 Seated in the filler cap adaptor is the handle end of a dipstick (7) incorporating a riveted spring steel blade carrying 'F' and 'L' oil level marks.

79 Oil is drawn from the tank by the steering unit upper pump through a hose (13) connected to an adaptor embodying a tubular gauze strainer (11) while the lower pump delivers oil from the sump through a steel pipe and a hose (3) to a section of the heat exchanger from which it returns to the tank through a hose (2), (refer also to Para 68 to 70).

80 The tank and the steering unit are ventilated by means of a lower steel pipe (15), a hose and an upper steel pipe, which is fitted with a steel wool type breather air cleaner (1) and is secured by an integral bracket on the rear corner of the steering unit left brake cover. The lower pipe is connected by a pipe (14) to a union (Fig 14 (79)) on the steering unit.

BRAKE AND STEERING CONTROLS

81 Fig 21 shows the steering levers and the mechanical linkage to the steering unit brake mechanism.

82 The right steering lever (6) is carried by two bushes (15), fitted to a stepped shaft portion, on a fulcrum pin (18) retained in a bracket (14) by a retaining washer (19). Keyed and clamped on the serrated end of the right steering lever shaft is a short lever (13), while pivoted by means of a bush (20) in a central position is a left steering lever (5). The bracket is bolted to a channel member welded on the hull bottom plate.

83 The left steering lever is connected by a short rod (39) to a medium lever (35) clamped on the serrated end of a cross-shaft (27) formed with an arm which is linked by a long rod (30) to the left brake operating lever on the steering unit. The short lever of the right steering lever is correspondingly connected to the right brake operating lever by two rods (38) and (36) and an intermediate composite lever (25).

84 Early type steering levers depend on the pressure of the brake band springs (Fig 7(11)) for returning them to the OFF position. Later type steering levers are each fitted with a tension spring (Fig 21 (44)) to ensure their return. Each spring is attached to an anchor pin (45) welded in the lever. The other ends of both springs are attached to an anchor pin (43) retained by two split pins in handle brackets welded to the lever bracket.

85 The cross-shaft is supported in two spherical bearings (29), each comprising a steel ball and steel outer member with bronze inserts which is pressed into a housing (28). Each housing is bolted to a bracket (23) welded in the angle between the hull bottom and lower front plates. The composite lever, which is supported on the cross-shaft by two bushes (31), protrudes through a rubber seal (33) and plate (34) bolted over an aperture in the hull longitudinal lower bulkhead.

NOTE

The steering lever and composite lever bushes are the dry type incorporating a fluorocarbon plastic (PTFE). Lubricating nipples are provided (refer to Para 89).

86 Mounted on the steering lever bracket are two micro-switches (Fig 21 (40)) which are connected to the stoplights and are operated by two striker screws (21) fitted one to each lever.

Parking control

87 Protruding through a screwed cap (Fig 21 (2)) on the upper end of each steering lever is a plunger (1) locked onto a rod (4) also fitted with a return spring (3). Secured on the lower end of each rod is a 4-toothed pawl (42) located between two guides (7) attached to a lever. Each pawl can be engaged with one of two ratchets (11) which, spaced by two distance pieces (10), are secured between bosses on the steering lever bracket by two through bolts (12). The bosses and distance pieces form stops for the levers.

Lubrication system

88 Four nipples are fitted for the lubrication of the cross-shaft bearings and lever bushes. One nipple is screwed into the composite lever and the remaining three are positioned to the front of a battery of five (Fig 21 (8)) that are mounted on an adaptor plate (9) attached to the steering lever bracket by the ratchet bolts.

89 The first three nipples on the adaptor plate are connected to pipes each made from Bundy tubing, two nipples and two union nuts. The front nipple is connected by two pipes (Fig 21 (22) and (26)). A bulkhead adaptor (24) and two double-ended unions (16) to the cross-shaft left bearing housing and the centre nipple by a pipe (37) and two unions to the right bearing housing. The third nipple is connected by a pipe (17) and two unions to the steering lever fulcrum pin. The remaining two nipples are connected by pipes and unions to the accelerator linkage cross-shaft bearings.

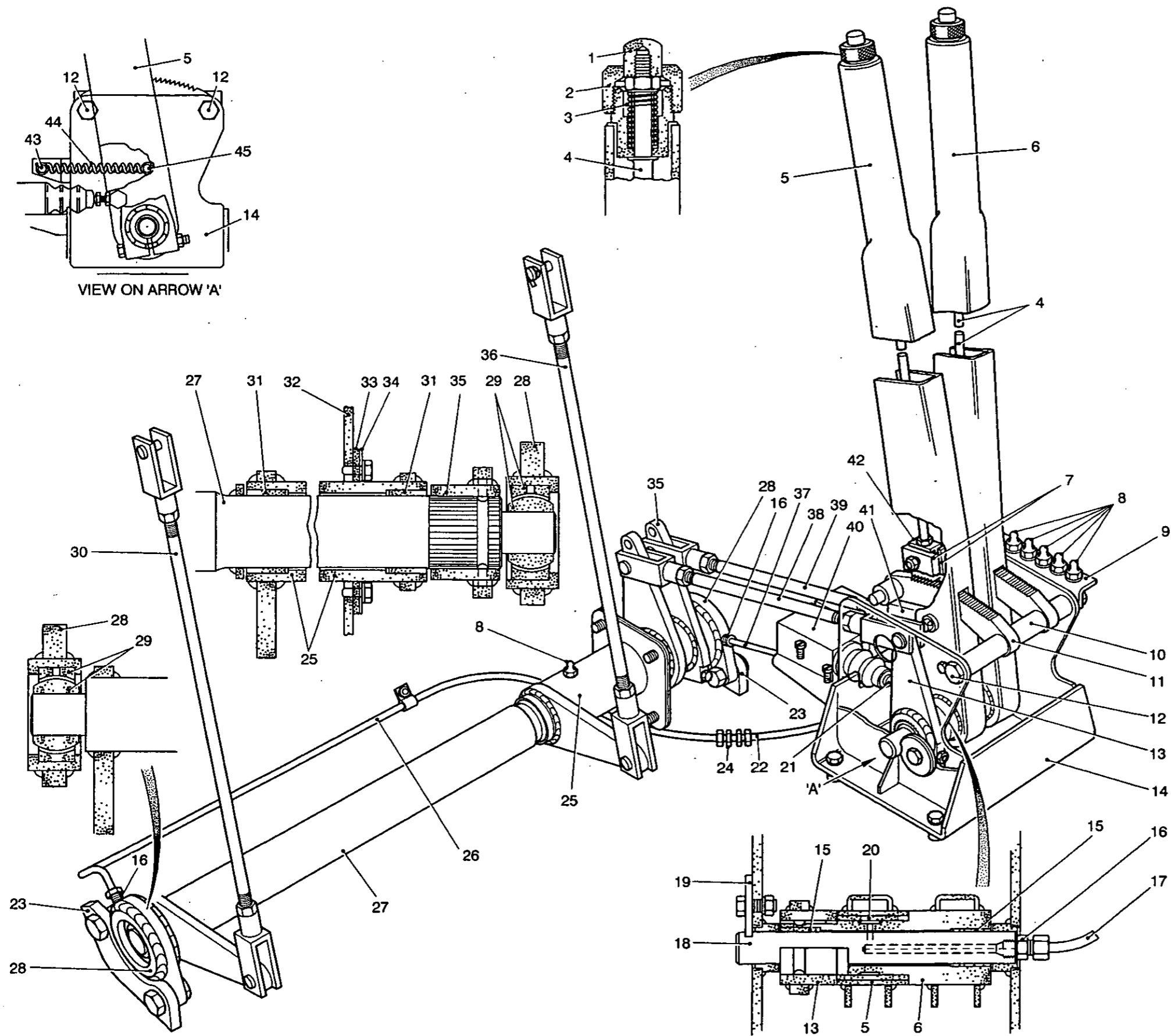

- 1 Plunger
- 2 Cap
- 3 Return spring
- 4 Rod
- 5 Left steering lever
- 6 Right steering lever
- 7 Pawl guide
- 8 Lubricating nipples
- 9 Lubricator adaptor bracket
- 10 Distance piece
- 11 Parking brake ratchet
- 12 Bolt
- 13 Short lever
- 14 Steering lever mounting bracket
- 15 Bush
- 16 Double ended union
- 17 Lubrication pipe
- 18 Fulcrum pin
- 19 Retaining washer
- 20 Bush
- 21 Striker screw
- 22 Lubrication pipe
- 23 Hull bracket
- 24 Bulkhead adaptor
- 25 Composite lever
- 26 Lubrication pipe
- 27 Cross shaft
- 28 Bearing housing
- 29 Spherical bearing
- 30 Long control rod
- 31 Bush
- 32 Longitudinal lower bulkhead
- 33 Seal
- 34 Seal plate
- 35 Medium lever
- 36 Long control rod
- 37 Lubrication pipe
- 38 Left short control rod
- 39 Right short control rod
- 40 Micro switch
- 41 Rod adaptor
- 42 Parking brake pawl
- 43 Spring anchor pin
- 44 Steering lever return spring
- 45 Spring anchor pin

Fig 21 Brake and steering controls

Operation

90 Fig 21 shows the steering levers in the OFF position against the stops on the bracket.

91 When the right lever is pulled back so to hold the right brake drum in the steering unit, it causes the vehicle to steer to the right. Similarly, when the left lever is applied, it causes the vehicle to steer to the left.

92 Simultaneous operation of both levers causes the vehicle to slow down and the stoplights to come on, while greater pressure sustained on the levers causes the vehicle to stop.

93 The levers are locked in the ON position, when parking, by means of the pawl and ratchet mechanism, after depressing the plungers. A slight backward movement given to the levers causes the pawls to be released by the reaction of the plunger return springs. Lever return springs ensure that later type levers return to the OFF position, when released.

HALF SHAFT ASSEMBLIES

94 The half shaft assemblies couple the drive from the controlled steering unit to the final drive units. The half shafts are flanged at each end, with the flanges being machined in the form of involuted teeth. The flanges of the half shaft (Fig 22 (5)) conform with the flanges of the shafts (9) and (6) of the steering and final drive units.

95 The flanges are coupled by means of a sleeve (4) having internally machined teeth matching those of the flange teeth. The sleeves are held in position by means of retaining plates (3).

96 The retaining plates are in the form of a split ring, each section being bolted to the flange by four bolts, the bolts (1) are locked in pairs by tab washers (7),

97 To prevent the ingress of dirt to the teeth an oil-sealing ring (8) is fitted and held in position by a spring clip (2) on each side of the coupling.

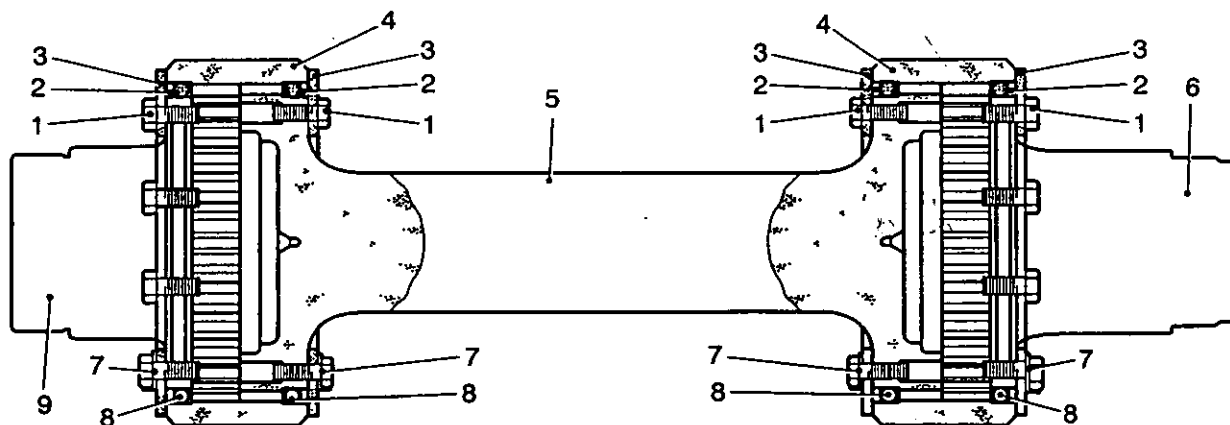

432/292

1	Bolt	6	Final drive shaft
2	Spring clip	7	Tab washer
3	Retaining clip	8	Oil sealing ring
4	Sleeve	9	Controlled steering unit output shaft
5	Half shaft		

Fig 22 Half shaft assembly

THROTTLE VALVE ACTUATOR

98 The throttle valve actuator (Fig 23) which is bolted to the left side of the Allison gearbox casing, comprises the actuator body having two pistons and a return spring which respond to fluid pressure variation from the fuel injection pump governor, the resultant movement via linkage operates two regulator valves (described in Para 90) which form part of the automatic gearbox hydraulic system.

99 The actuator body (10) with press fit guide bush (8) is attached by bolts to a bracket welded cover plate on the gearbox casing. The upper of two pistons (6) and (11) has a composition 'Belloform' diaphragm (5) secured by a centre bolt and washer (4) to the piston crown, the diaphragm flange is clamped between the flanged end of the body and the actuator head (3), the actuator head retained by bolts has an adaptor (1) positioned centrally to provide a connection for the pipe assembly from the injection pump governor. Fluid from the governor, the pressure of which, is proportional to the engine speed, is piped through to the actuator head chamber causing the upper piston sealed by the diaphragm to descend into the actuator body, the piston spigot together with a steel seating ball (9) fit into an orifice in the lower piston head, thereby transmitting the axial movement through to the lower piston, both pistons moving as one. A stop washer (7) seating against an abutment in the body bore prevents the upper piston from exceeding its planned stroke. The adaptor (15) with press fit bush (14) screwed into the lower end of the actuator body and secured by a lock nut (13) acts as a guide for the lower piston, and also retains an internal coil spring (12) that provides the piston return action, spring pressure being applied to an abutment on the lower piston. A rubber boot (16) which fits over the end of the adaptor provides a dust and moisture seal for the lower end of the actuator, the connecting rod integral with the lower piston, passes through the rubber boot and has attached to its threaded end a fork end (17) secured by a lock nut. A forked link with pin connections provides the attachment between the fork end and an operating lever clamped to the gearbox throttle regulator valve spindle.

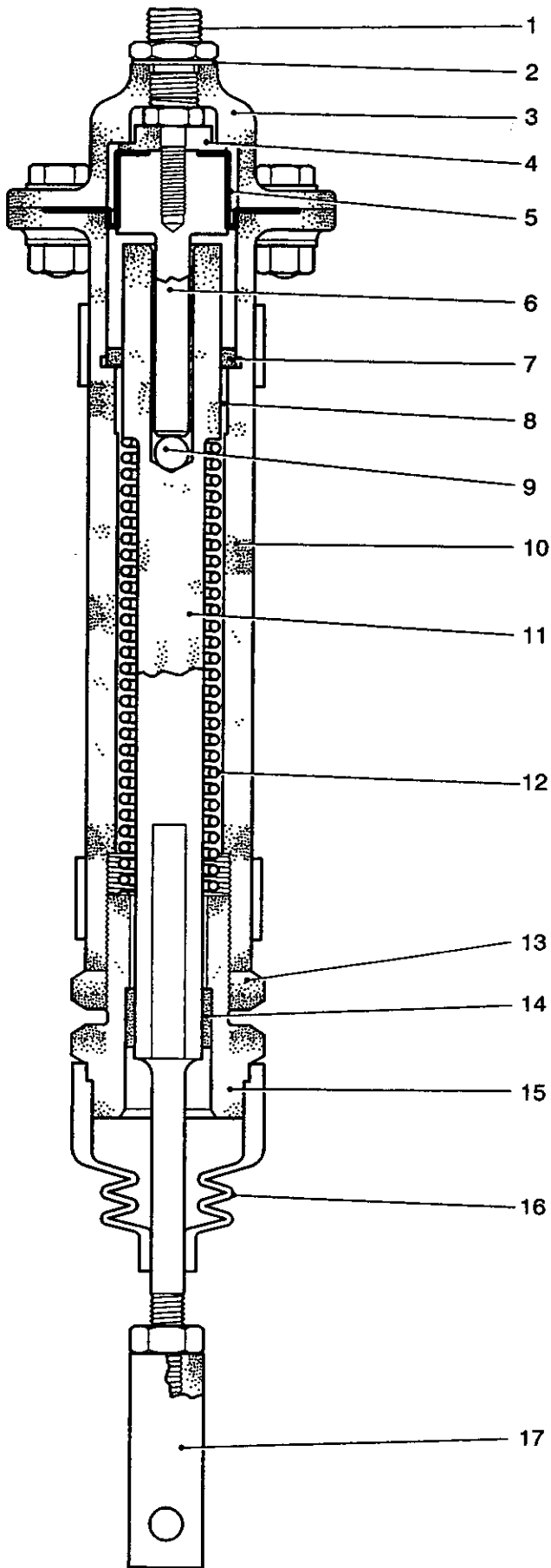

- 1 Adaptor
- 2 Washer
- 3 Actuator head
- 4 Washer
- 5 Diaphragm
- 6 Piston (upper)
- 7 Stop washer
- 8 Bush
- 9 Ball
- 10 Body
- 11 Piston (lower)
- 12 Spring
- 13 Lock nut
- 14 Bush
- 15 Adaptor
- 16 Rubber boot
- 17 Fork end

432/294

Fig 23 Throttle valve actuator

CHAPTER 2

FINAL DRIVE, SUSPENSION AND TRACKS – LIST OF CHAPTERS

CONTENTS

Para

- 1 List of chapters (this chapter)

LIST OF CHAPTERS

- 1 This chapter is further sub-divided as follows:

Chap

- 2-1 Final drives
- 2-2 Suspension and tracks

CHAPTER 2-1

FINAL DRIVES

CONTENTS

Para

1 Final drives

Fig

Page

1 Final drive..... 2

FINAL DRIVES

1 The final drive is a 4:15 to 1 ratio single reduction gear, the pinion (Fig 1(12)) being driven by the half shaft from the steering unit and the driven gear (14) driving the sprocket hub (26). The assembly is mounted in a housing which is manufactured in two parts, an outer casing (7) and an inner housing (8). A filler plug and a drain plug (24) are provided in the outer casing. The two parts are secured together by three countersunk screws (23) disposed round the rim then bolted as a unit to an adaptor welded to the hull side-plate and dowelled in position. After fitting, the two dowels are secured by peening over the ends of the dowel holes. Both final drives are similar except that the speedometer drive is taken from the right hand final drive.

2 The pinion shaft is mounted in two taper roller bearings, one in the outer casing, and the other in the inner bearing housing. Two tapped holes through the outer casing fitted with grub screws (5) provide means of removing the cup (6) of the race from the bore. The inner bearing is retained by an oil seal housing, (13) which is bolted to the bearing housing. Shims between the housings allow the bearings to be adjusted correctly. The oil seal (9) contacts the outside of a driving flange (10), which is fitted onto the splines on the pinion shaft. The flange and the cone of the inner bearing are locked onto the shaft by a washer and a split-pinned slotted nut (11). The inner end of the driving flange is coupled to the half shaft by an internally toothed sleeve.

3 The driven gear is bolted to a flange on the main shaft (15) which is mounted in two taper roller bearings, the outer bearing (25) fitted in the outer casing, the inner bearing (22) in the inner housing. An abutment in the housing positions the cup of the inner bearing and the cones of both bearings positioned by abutments on the main shaft. The cup of the outer bearing is positioned by an oil seal housing (27) bolted to the outer casing. Shims fitted between the housing and casing allows the bearings to be adjusted correctly. The outer face of the oil seal housing is machined to form a labyrinth (32) with the sprocket hub.

4 The sprocket hub is fitted on the splined end of the main shaft, which protrudes from the outer casing and is secured by a slotted nut (29). The hub centre is provided with two tapped bosses (not shown) for extraction purposes. A plate held by two set bolts locks the nut. These bolts are screwed into the end of the main shaft and locked with wire (30). The oil seal housing carries two oil seals (31) which seal the outer casing by contacting a sleeve which is a force fit on the projection on the inside of the hub. Filling the space between the hub and oil seal housing with grease prevents ingress of foreign matter through the labyrinth. A lubricator (28) is provided in the hub for this purpose.

5 The sprockets (1) are bolted to flanges round the hub, a dowel (2) in each flange ensuring correct positioning. The flanges and the bore of the sprockets are interrupted so that the inner sprocket can be removed without first removing the hub.

6 The speedometer driving gear (16) is bolted to the inner end of the main shaft and meshes with the driven gear (18) which is held in a speedometer drive housing (19) bolted to the inner bearing housing. The shaft of the gear runs in two bushes pressed into the drive housing and is positioned by a collar pressed onto the shaft after it is fitted into the housing. An adaptor (17) is bolted to the drive housing, the other end of the adaptor being threaded to fit the speedometer cable connector. The cable connects into the end of the shaft. The speedometer gears are lubricated through an oil hole drilled in the inner bearing housing from a trough which catches oil thrown off by the pinion and driven gear, to the back of the inner taper roller bearing of the main shaft. The oil drains back to the outer casing through a hole in the bottom of the bearing housing.

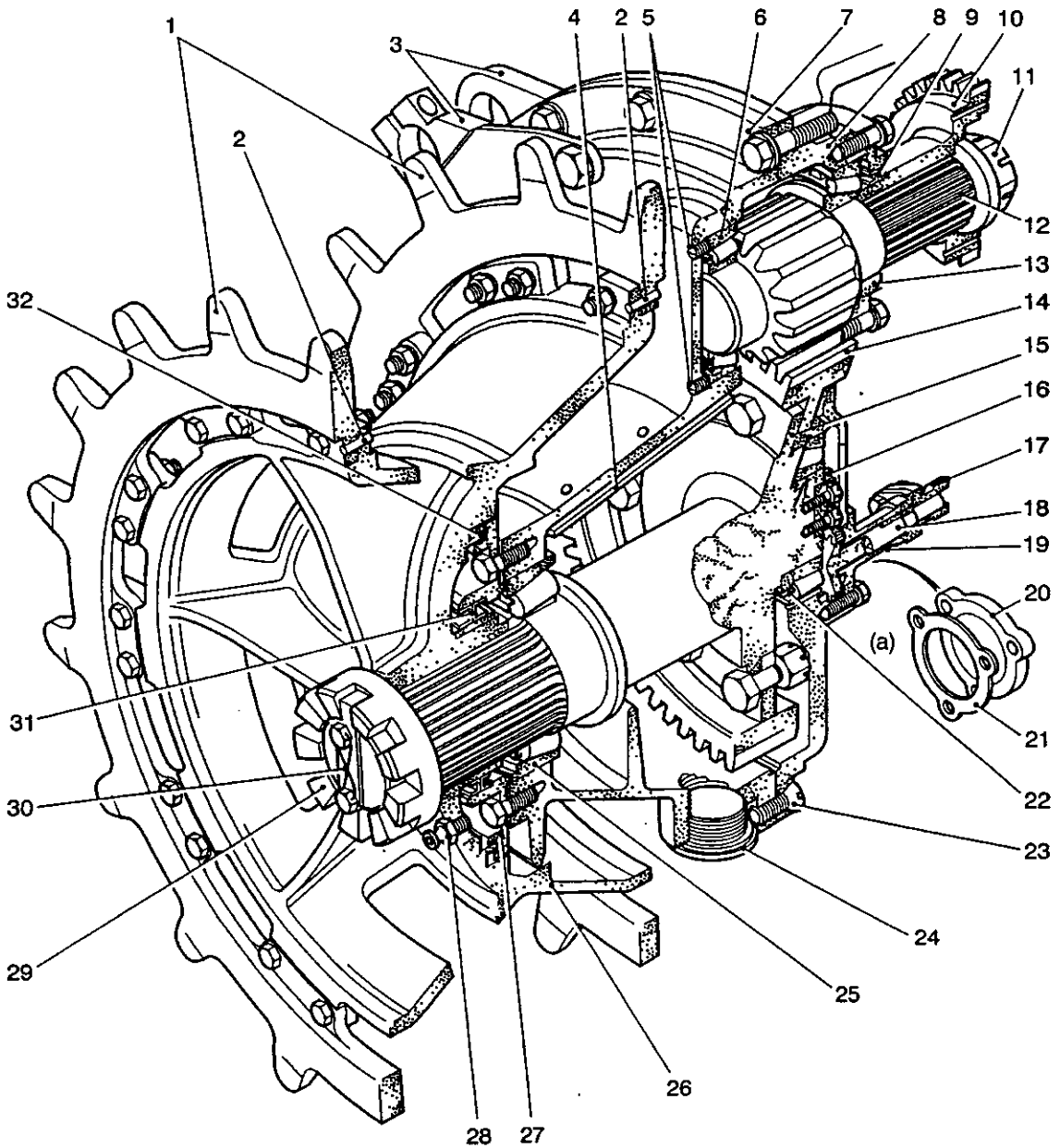

432/293

- | | | | | | |
|----|-------------------------|----|---------------------------|-----|---|
| 1 | Sprockets | 13 | Oil seal housing | 25 | Outer bearing |
| 2 | Dowel | 14 | Driven gear | 26 | Sprocket hub |
| 3 | Shock absorber brackets | 15 | Main shaft | 27 | Oil seal housing |
| 4 | Oil deflector plate | 16 | Speedometer driving gear | 28 | Lubricator |
| 5 | Grub screws | 17 | Speedometer adaptor | 29 | Slotted nut |
| 6 | Pinion bearing cup | 18 | Speedometer driven gear | 30 | Locking wire |
| 7 | Outer casing | 19 | Speedometer drive housing | 31 | Oil seal |
| 8 | Inner bearing housing | 20 | Blanking plate | 32 | Labyrinth |
| 9 | Oil seal | 21 | Joint | (a) | Blanking plate fitted in place of speedometer drive housing on LH final drive |
| 10 | Driving flange | 22 | Inner bearing | | |
| 11 | Slotted nut | 23 | Countersunk screw | | |
| 12 | Pinion | 24 | Drain plug | | |

Fig 1 Final drive

CHAPTER 2-2
SUSPENSION AND TRACKS
CONTENTS

Para

- 1 General
- 2 Axle arm bracket
- 4 Axle arm
- 5 Wheel hub assembly
- 10 Wheels
- 11 Torsion bars
- 14 Guide rollers
- Track adjusters
- 16 Hydraulic
- 18 Operation
- 20 Shock absorbers
- 21 Bump stop

Fig

Page

1	Axle arm brackets and torsion bars	3
2	Axle arm, road wheel and hub	5
3	Guide roller	7
4	Hydraulic track adjuster - LH.....	8
5	Shock absorber.....	9

GENERAL

1 The vehicle is supported at each side on five pairs of independently sprung road wheels, which are mounted, to operate in a trailing position. Each pair of wheels is bolted to a hub, which turns on a ball and a roller bearing fitted on a stub axle projecting from an axle arm. The axle arm pivots in two bushes in a bracket welded in the hull. The pivot tube of the axle arm has connected to it a torsion bar, which extends across the hull to a fixture in the axle arm bracket on the opposite side.

AXLE ARM BRACKET

2 The cast steel bracket (Fig 1 (10)) is flanged mid-way along its length, with a channel-sectioned extension formed on the inner side of the flange. The flange is set at the same angle as the slope of the lower side plates. The bracket is welded to the hull with the channel extension entering the floor channel, which forms a housing for the two torsion bars of opposite suspension stations. The cylindrical part of the casting which receives the pivot tube of the axle arm (4) is bored longitudinally and bushed (8) and (11) at each end. After assembly, the bushes are reamed in line. At the inner end the bore is counterbored for an oil seal (12). At the outer end, in the case of early vehicles, the bore is counterbored to two diameters, the smaller diameter for an oil seal (7), the larger diameter for a felt seal (5) and a support washer (6). In the case of the later vehicles as seal (24) replaces items (5), (6) and (7). The outer end is drilled for a nipple (9) through which the bushes are lubricated and for two bolts, which secure a retaining plate to prevent the axle arm working out of the bracket, should the torsion bar break.

3 Formed on the side of the cylindrical part of the casting is a housing for anchoring the torsion bar (13) of the opposite suspension unit. It is bored through vertically for the anchor block (17) with counterbores at each end for a sealing ring (20) and a plate (19). On the inner side of the housing is drilled for the passage of the torsion bar and on the outer side it is drilled and tapped for a plug (21), which allows access to the end of the torsion bar. Below the plug is a locking bolt (22) for the anchor block.

Axle arm

4 The axle arm comprises the arm, stub axle, pivot tube, distance piece and four taper dowels. The arm (Fig 2 (16)) is a hollow casting bored transversely at each end to receive the stub axle (13) and the pivot tube (17). On an arm used at a front or rear station, two flanges are formed mid-way along the top to provide means of attaching the shock absorber. The stub axle is a driving fit in the arm where it is welded in position after fitting. The distance piece (10) is fitted on the stub axle abutting the arm, and positions the wheel hub assembly. It is machined externally to fit into the oil seal housing (4) on the hub and also to provide a sealing face for the inner part of the floating ring seal (11). The other end of the arm is set at an angle to counteract the off-square position of the torsion bar across the vehicle and so bring the stub axle square to the hull. The pivot tube is fitted into the arm, fixed by four tapered dowels and welded in position. The edges of the holes round the heads of the dowels are peened over to prevent the dowels loosening. Internally, the tube is serrated to suit the serrations on the torsion bar and threaded at the outer end for the locking sleeve (Fig 1 (1)), which retains the torsion bar bearing washer (16). The arm and tube are drilled and tapped for a locking plug (15) and bolt (2) which secure the locking sleeve; on some vehicles the plug (15) and bolt (2) have been replaced by a socket set screw and a larger aluminium plug. On the front stations the front of the arm is cut away to provide clearance for the sprocket wheel.

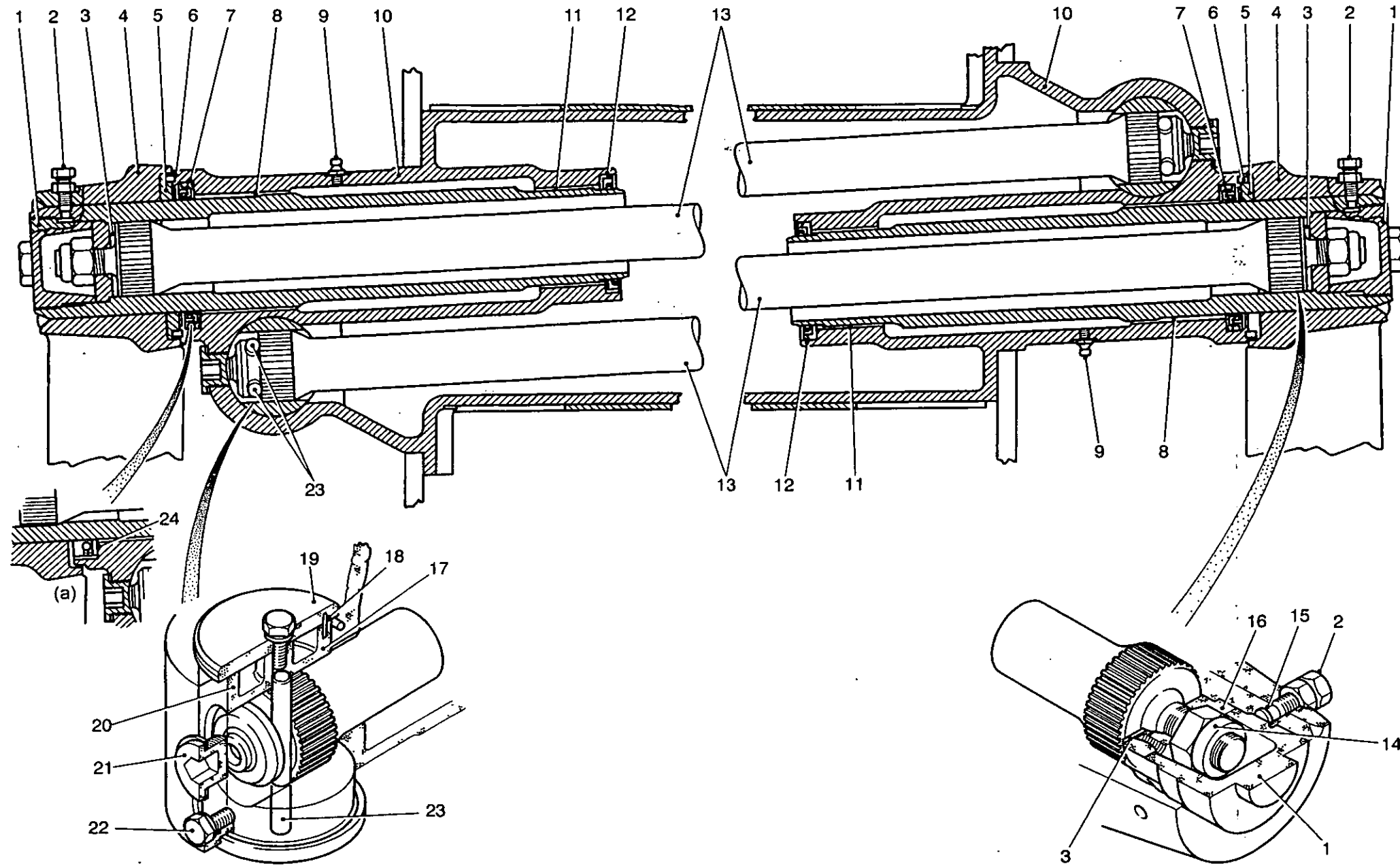

- | | | | | | | | |
|---|--------------------------|----|--------------------|----|------------------|----|-----------------------------|
| 1 | Locking sleeve | 7 | Oil seal | 13 | Torsion bar | 19 | Anchor block securing plate |
| 2 | Locking bolt | 8 | Bush | 14 | Self-locking nut | 20 | Sealing ring |
| 3 | Shims | 9 | Lubricating nipple | 15 | Aluminium plug | 21 | Plug |
| 4 | Axle arm | 10 | Axle arm bracket | 16 | Bearing washer | 22 | Locking bolt |
| 5 | Felt seal | 11 | Bush | 17 | Anchor block | 23 | Anchor pins |
| 6 | Felt seal support washer | 12 | Oil seal | 18 | Peg | 24 | Seal (see (a) below) |

(a) Inset showing seal 24 which in later vehicles replaces items 5, 6 and 7

Fig 1 Axle arm brackets and torsion bars

WHEEL HUB ASSEMBLY

5 The hub (Fig 2 (3)) is a hollow, light alloy casting, counter bored at each side to receive a ball bearing on the outside and a roller bearing on the inside. Two grooves in the abutment behind the outer race of the roller bearing facilitate the removal of the race. The race is secured by a spigot on the oil seal housing (4), which is bolted to the inner face of the hub. The boltholes are irregularly disposed so that the housing can be assembled only in one position. Internally the housing is machined to fit over the distance piece (9) on the stub axle (13) and to form a sealing face for the outer 'O' ring of the floating ring seal (11). The body of the ring seal is made in mated halves which fit loosely round the distance piece (10) on the stub axle and two sealing 'O' rings fit one into the tapered cavity formed between the body and the distance piece, the other in the cavity formed between the body and the oil seal housing. The compressed 'O' rings hold the halves and force them together. The ground inner face of each half is relieved towards the centre so that only a narrow contact is made to form an oil seal.

6 The inner races of the bearings are separated by a distance piece (9). Means of lubricating the bearings is provided by fitting a hexagon headed plug (15) with a sealing washer, in the hub. The flange of the hub is drilled for the bolts securing the road wheels and, at the root of the flange; the hub is machined to fit the discs of the road wheels. Two wheel locating pins (14) are screwed into the flange in diametrically opposite positions and the protruding parts of the threads are peened over to lock them.

7 The hub assembly is retained on the stub axle by a washer and nut (5), which clamps the inner races and distance piece against the distance piece on the stub axle. The nut is locked by a tab washer, which has an inner tab fitting into a slot in the stub axle and an outer tab knocked up against a face of the nut.

8 The bearings are enclosed by a cap (7) bolted to the face of the hub. The cap also secures the outer race of the ball bearing. Anti-static components to eliminate radio interference are fitted between the road and tensioner wheel hubs and stub axle.

9 The track adjusting wheel hub assemblies are similar to the road wheel hub assemblies with the exception of the hubs and locating pins. The hubs are shaped to provide a wider face for the wheel discs between which distance pieces are fitted to widen the gap between the wheel rims. The locating pins are proportionately longer. To overcome the loosening of the wheel bolts a spreader ring is fitted under the heads of the bolts.

Wheels

10 The road and track adjusting wheels are interchangeable and are made in two parts, the disc and the rim. The rubber tyre is vulcanised to the rim afterwards. The disc is dished and welded inside the rim in a position to give a clearance of 9.5 mm (3/8in.) between the face of the disc and the side of the rim. The disc is bored to fit on the hub and the rim is machined concentric to the bore within a fixed tolerance. Holes spaced equi-distant round the bore, are provided for securing the disc to the flange on the hub and two tapped and two plain holes are provided respectively, for withdrawing the wheels from the hub and for locating it. The tapped holes are not equally spaced between boltholes. Eight weight reduction holes are drilled in the disc. The rim on the convex side of the wheel is flame or induction hardened and the side of the tyre is relieved to withstand wear due to the rubbing of the horns on the tracks. The wheels are mounted on the hubs in pairs with the convex sides of the wheels together so that there is a gap between the wheels for the horns on the track links. On the track adjusters, distance pieces are fitted between the wheels so making a wider gap. On some vehicles the hubcap (7) and oil seal housing (4) securing bolts have been replaced by studs and nuts.

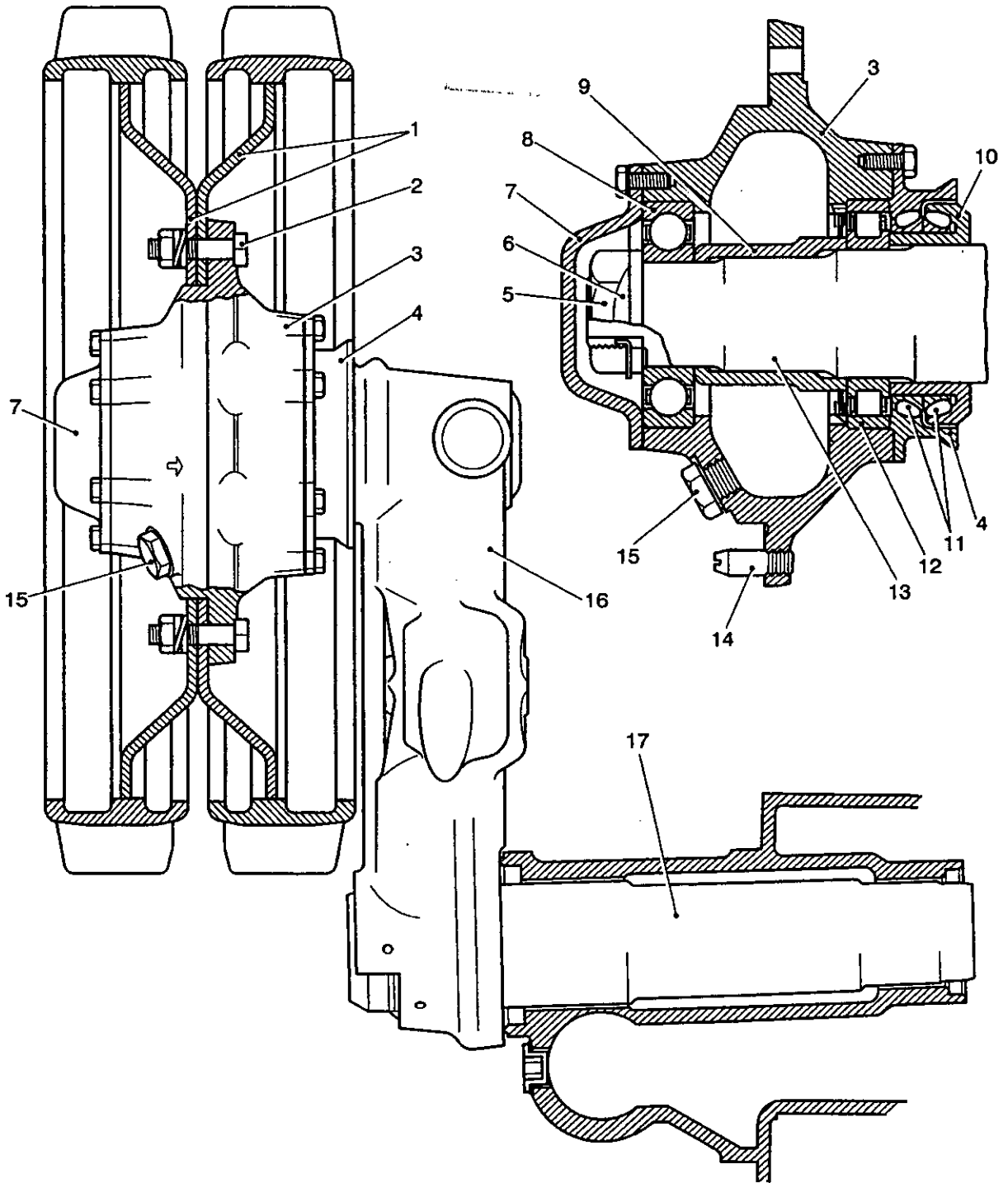

432/269

- | | | | | | | | |
|---|---------------|---|----------------|----|----------------|----|---------------------|
| 1 | Wheel | 6 | Tab washer | 10 | Distance piece | 14 | Locating pin |
| 2 | Bolt | 7 | Hub cap | 11 | Sealing ring | 15 | Oil plug |
| 3 | Hub | 8 | Ball bearing | 12 | Roller bearing | 16 | Axle arm |
| 4 | Seal housing | 9 | Distance piece | 13 | Stub axle | 17 | Axle arm pivot tube |
| 5 | Stub axle nut | | | | | | |

Fig 2 Axle arm, road wheel and hub

Torsion bars

11 An axle arm bracket (Fig 1 (10)) is mounted on each side of the vehicle. Each carries an axle arm (4) and embodies an anchorage for one end of a torsion bar (13). The other end of each torsion bar is located in the axle arm on the opposite side of the vehicle. The anchor block (17) fits into the axle arm bracket where it is retained by a locking bolt (22) engaging a slot in the block. The block is drilled transversely and serrated to receive the end of the torsion bar and drilled and reamed longitudinally for two anchor pins (23) that fit in a groove machined round the end of the torsion bar. The block is sealed at each end in its housing by a sealing ring (20) fitting round the block in a groove in the axle arm bracket and a plate (19) which is secured to the block by a central bolt and spring washer. Each plate is prevented from rotating and damaging the sealing ring when the bolt is tightened by a peg (18), fitted into the block engaging in a hole drilled in the plate. The plates also prevent movement of the two anchor pins. In addition to the lubricating nipple (9) a secondary nipple has been introduced to improve the lubrication of the outer bush.

12 The torsion bars are machined and ground along their length between the splines, shot peened and covered with a synthetic rubber protective. They are also pre-set, those to be used on the right side of the vehicle being pre-set clockwise, those to be used on the left being pre-set anti-clockwise. An arrow stamped on the road wheel end of the torsion bar marks the direction of pre-setting. The splines at each end of the bars are of similar form but at the anchored ends there are 42 serrations on a 53.3 mm (2.1 in.) diameter and at the axle arm ends, 44 serrations on a 55.9 mm (2.2 in.) diameter. A tapped hole is provided for fitting purposes in the end of the bar at the anchored end.

13 The serrations on the larger diameter fit into serrations in the pivot tube of the axle arm and the axle arm is retained by a bearing washer (16), which is tightened against an abutment in the tube by a self-locking nut (14) on the end of the torsion bar. Shims (3) are fitted between the bearing washer and the shoulder on the torsion bar at the end of the serrations. The pivot tube end is closed by a locking sleeve (1), which is screwed into the end of the tube until tight against the bearing washer (16). The sleeve is locked by a bolt (2) screwed through the axle arm, which forces an aluminium plug (15) on to serrations round the body of the sleeve. The bolt is fitted with a locknut.

Guide rollers

14 Two guide rollers, which are bolted to the hull sideplate, support the top run of each track. The brackets (Fig 3 (9)) supporting the rear rollers differ from those supporting the front by being off-set, one to the left and the other to the right, to provide a top anchorage for the rear shock absorbers. Each roller hub (14) is mounted on a spindle (11), which is an interference fit in the bracket. The spindle is secured by a Mills pin (10) the end of which protrudes from the bracket.

15 A rubber tyred roller (3) is secured to each side of the hub by studs, nuts and spring washers, the rim of the roller round the flange on the hub. The hub is mounted on the spindle on two bearings (2) and (5) which are separated by a distance piece (4) and the inner bearing abuts an inner distance piece fitted on the spindle. The male member of a labyrinth is machined on the flange of the inner distance piece, the female member being machined in the oil seal housing (7). The oil seal (6) is pressed into the housing and seals round the circumference of the inner distance piece. A dirt excluder (8), which covers the entrance to the labyrinth, and the oil seal housing, are secured to the hub by studs, nuts and spring washers. The hub is retained on the spindle by a washer, slotted nut (15) and split pin. A cap (18) to prevent ingress of dirt to the bearings is secured to the hub by studs, nuts and spring washers. A nipple (17) is provided in the hubcap for the lubrication of the bearings.

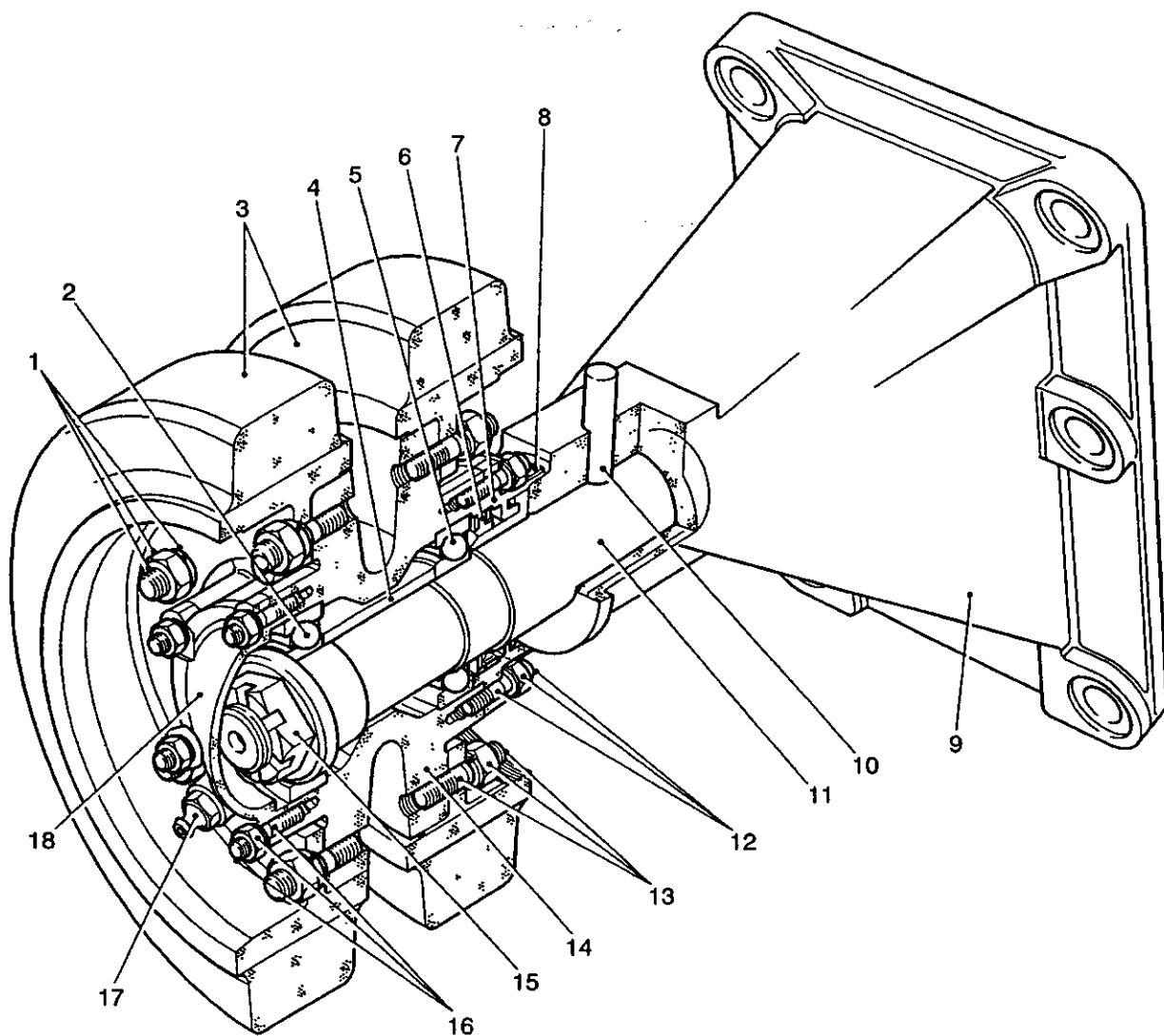

432/270

- | | | | |
|---|-----------------------------|----|--------------------------------|
| 1 | Stud, nut and spring washer | 10 | Mills pin |
| 2 | Ball bearing | 11 | Spindle |
| 3 | Rubber tyred roller | 12 | Stud , nut and spring |
| 4 | Distance piece | 13 | Stud |
| 5 | Ball bearing | 14 | Roller hub |
| 6 | Oil seal | 15 | Stotted nut |
| 7 | Oil sealing housing | 16 | Stud, nut and
spring washer |
| 8 | Dirt excluder | 17 | Lubricating nipple |
| 9 | Bracket, front guide roller | 18 | Hub cap |

Fig 3 Guide roller

Track adjustersHydraulic

16 Each hydraulic track adjuster (Fig 4) consists of a cylinder (20) and a ram (8) of the single acting type. The cylinder has a central collar against which abuts a pressed on trunnion (15) by which the adjuster is attached to the vehicle. The front end of the cylinder is closed by a screwed end cap (19) incorporating a grease nipple (2) and a pressure release screw (1).

17 A seal cap (6) is screwed onto the rear end of the cylinder and is fitted with a water and dirt excluding seal (7). The end of the ram (8) is shaped to match the contour of the stub axle (11) it abuts. The effective ram-adjusting stroke is about 4in.

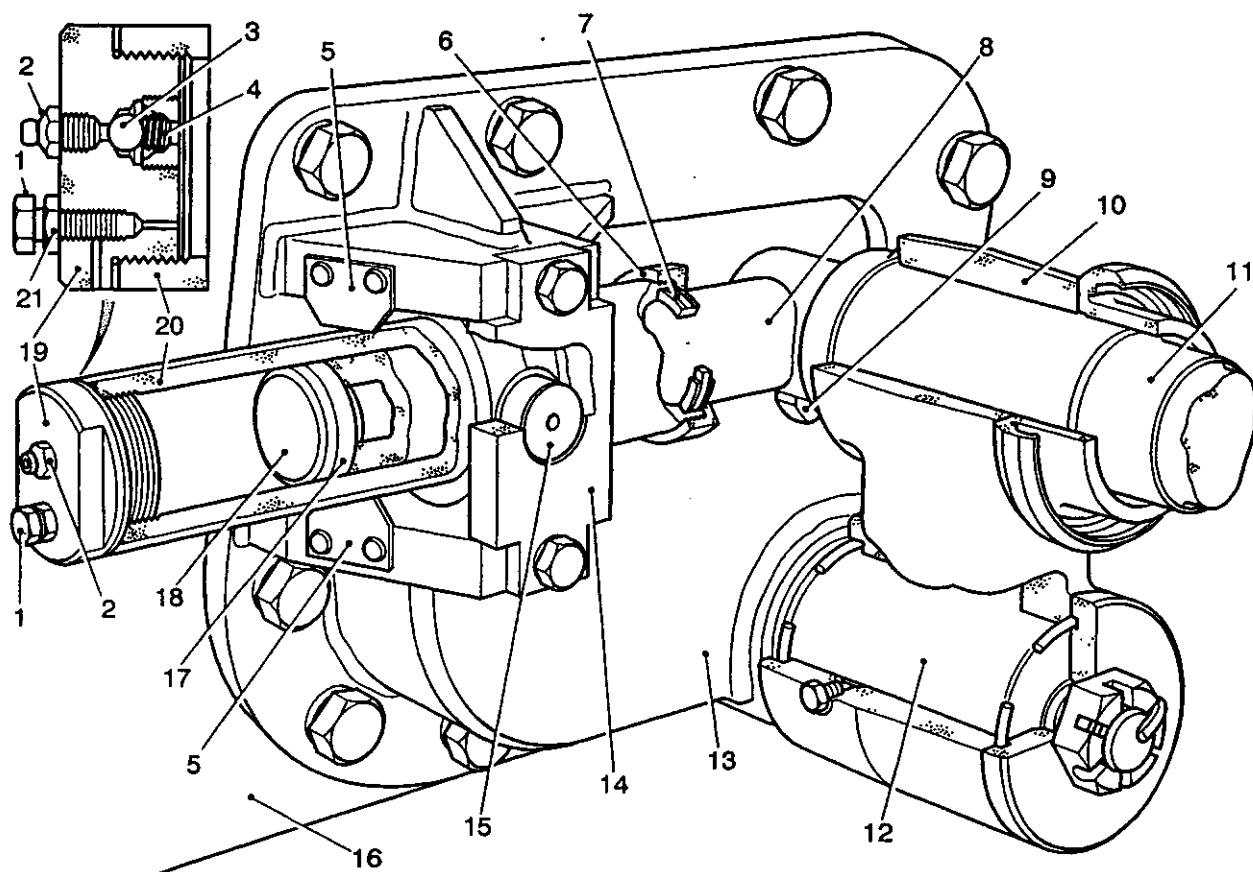

432/272

1	Pressure release screw	12	Adjusting arm pivot
2	Grease nipple	13	Track adjuster bracket
3	Non-return valve ball	14	Trunnion bearing plate
4	Spring	15	Trunnion
5	Stop	16	Hull side plate
6	Seal cap	17	Distributor seal
7	Seal	18	Plug
8	Ram	19	End cap
9	Stop	20	Cylinder
10	Adjusting arm	21	Lock nut
11	Stub axle		

Fig 4 Hydraulic track adjuster – LH

Operation

18 Grease is pumped into the cylinder via the grease nipple (2). This forces the piston rod and adjusting arm rearwards until the correct track adjustment is achieved, or until the available range of adjustment has been taken up. In the latter case further movement of the arm is prevented by a stop (9) welded to the inner end of the stub axle abutting the rear of the track adjuster bracket (13).

19 To return the ram to the point of minimum adjustment the pressure release screw (1) is almost completely withdrawn and the adjusting arm (10) levered forwards as far as possible, therefore emptying the cylinder of grease through the port uncovered by the withdrawal of the pressure release screw. The pressure release screw is then replaced and secured against movement by the lock nut (21). The full range of adjustment is again available.

Shock absorbers

20 The shock absorbers are friction type and are fitted on the front and rear stations of the suspension. Each absorber consists of a barrel in which a spring expanded shoe assembly slides. The barrel (Fig 5 (2)) is a tube to which a head is welded and through the head a silent-bloc type flexible bush (1) fitted. The open end of the tube is chamfered to provide a lead-in when inserting the shoe assembly. The head of the rod (9) carrying the shoes is fitted with a flexible bush (12) identical to that in the barrelhead. Fitting on the rod under the head is a seating (11) for the spring (10) and compressing the spring is a washer (8) two loading rings (6) a special washer (5) and a slotted nut (3) secured by a split pin. The loading rings have three equally spaced chamfered faces and are assembled on the rod so that the faces form vee grooves. The three shoe assemblies (4) and (7) are identical and each consists of a shoe (7) with a Ferodo lining (4) bonded to the curved face. The inside of the shoe has a wedge shaped prominence which fits exactly into a vee groove formed by the chamfered faces on the loading rings. When assembled the friction between the tube and shoes must give a pull-off load of pre-determined value and this is obtained by adjusting the compression on the spring (10) by means of the nut (3) on the rod.

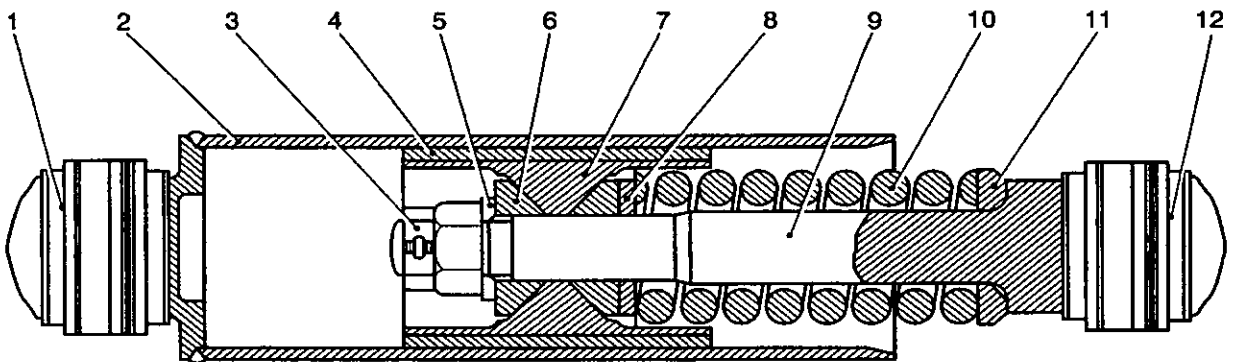

432/273

- | | | | |
|---|-----------------------|----|----------------|
| 1 | Flexible bush | 7 | Shoe |
| 2 | Barrel | 8 | Washer |
| 3 | Slotted nut | 9 | Rod |
| 4 | Brake lining material | 10 | Spring |
| 5 | Special washer | 11 | Spring seating |
| 6 | Loading ring | 12 | Flexible bush |

Fig 5 Shock absorber

Bump stop

21 A bump stop is provided at each suspension station. It comprises four rubber rings with steel rings vulcanized at top and bottom, the bottom rings being lipped to slide over the centre bolt when the rubbers are compressed. The four rings are assembled together by spot welding the steel rings. The top ring is spot welded to a plate through which the centre bolt is fitted and welded in position. The head of the centre bolt is cylindrical and is of a length to limit the compression of the rings. The bottom ring is spot welded to a plate formed with a spherical bulge, which makes contact with a depression in the axle arm when the road wheel is lifted too high. The bump stop assembly is secured to a bracket on the vehicle side plate by a self-locking nut on the centre bolt. Some vehicles are fitted with a later pattern shock absorber in which the rod (9) had been replaced by a rod with a larger diameter thread. The nut (3), washer (5) and the split pin are replaced by a special castellated nut and spring locking ring.

CHAPTER 3
HULL AND FITTINGS
CONTENTS

Para

1	Hull
3	Power pack compartment roof
9	Driver's hatch
11	Periscope washer
12	Periscope wiper
14	Periscope gearbox
29	Clutch operation
31	Interlock and switch
34	Starting and stopping the wipers
35	Mortar hatch
39	Commander's cupola
45	Periscopes and wiper
47	Rear door
49	Dischargers, smoke grenade, No. 8, Mk 1
53	Driver's seat
62	Seat harness
68	Commander's seat
73	Personnel seats
74	Sliding table assemblies
75	Weapon stowage
76	Fire fighting equipment
83	Fire alarm system
86	Hoist unit

Fig		Page
1	Hull floor access plates and drain plugs from below	2
2	Power pack compartment roof,	4
3	Driver's hatch	5
4	Typical hatch handle.....	5
5	Periscope gearbox.....	9
6	Mortar hatch.....	11
7	Commander's cupola	13
8	Discharger, smoke grenade, No. 8, Mk 1	15
9	Driver's seat	17
10	Commander's seat	19
11	Personnel seats	20
12	Fixed fire fighting	22
13	Hoist unit stowage brackets	23/24

HULL

1 The hull is fabricated from armour plate, welded to form a unit, which is sub-divided by a bulkhead and division plates into compartments for crew, power pack and personnel respectively.

2 Welded brackets on the lower side plates provide attachment points for the final drives and suspension units, and an aperture with a hinged door in the front sloping plate (glacis plate) gives access to the steering unit. The rear plate has an opening with a hinged door to provide a means of entry to the personnel compartment. An armoured box with twin hinged doors welded to the right upper side plate houses the ventilation filters. An aperture positioned to the front left of roof plate has detachable louvres that facilitate removal of the power pack. Adjacent to it are two openings that give access to the crew compartment, the forward opening with hinged door provides the driver's entry hatch and to its rear is positioned the commander's hatch taking the form of a rotatable cupola with hinged door. The rear section of the roof plate has a large circular aperture (mortar hatch), which opens, onto the Command staff compartment. The aperture is fitted with twin semi-circular folding hinged doors. The power pack/crew compartment division plates are de-mountable to give access to the power pack.

NOTE

The roof mounted equipment basket and lighting brackets for the bowman radio fit equipment, stop the mortar hatch from being opened and restrict rescue capability.

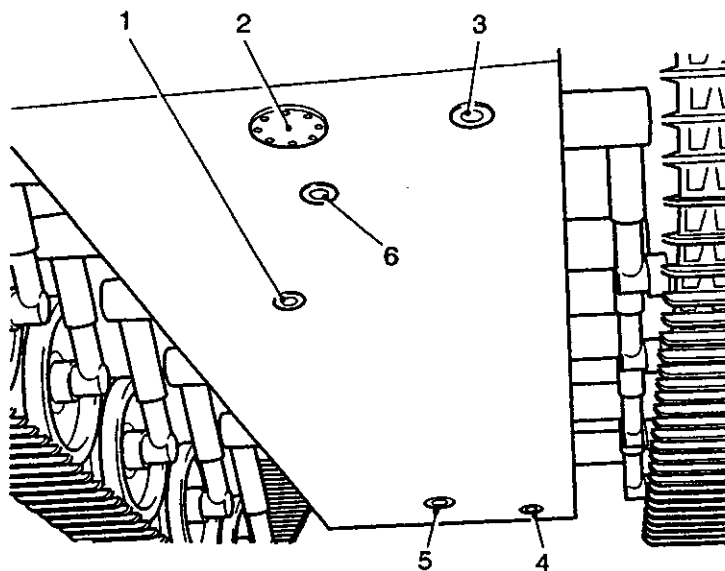

432/052

- | | | | |
|---|--|---|-------------------------------|
| 1 | Gearbox drain access plug | 4 | Hull drain plug |
| 2 | Steering unit drain access plate | 5 | Fuel drain valve access plate |
| 3 | Steering unit oil tank and coolant drain access plug | 6 | Engine oil drain access plug |

Fig 1 Hull floor access plates and drain plugs from below

Power pack compartment roof

3 The roof (Fig 2) has two torsion bar assisted louvres, retained by turncatches and clamp plates, giving access to the radiator, air cleaner and cooling fans.

4 The front support (23) is chevron shaped in section with the forward face bolted to the underside edge of the glacis plate allowing the top face to protrude to support the front flange on the inlet louvre. The middle support (5) is fabricated of plate to form a channel section and is secured by two bolts at each end to supporting plates welded along the sides of the aperture in the roof. A sealing strip is bolted to the inside of the channel to deflect the air through the radiator. The radiator filler cover, oil tank filler cover and dipstick cover are located in the support. The hydraulic oil tank filler and dipstick, however, have been repositioned beneath the outlet louvre, adjacent to the air cleaner restriction indicator, and two louvre clamping plates (15) are bolted on either side of the radiator filler cover (4).

5 The inlet louvre (24) comprises of a frame with a centre strip to which are welded forward facing chevron section louvre bars, a mounting flange is formed from plates welded round the frame, this flange has turn-catches (7) mounted upon it that clamp the louvre to the front support plate and hull roof. A channel section extending the full length of the louvre, divides the airflow between the radiator and the engine air cleaner units. Four hinge lugs are welded to the louvre frame, the two inner lugs provide anchor points for the two laminated torsion bar attachment blocks (20), each block has a Mills pin driven into it to prevent it passing through its respective lug. Each torsion bar (22) comprises sixteen spring steel strips enclosed in a tube, which are loaded by being turned through 90 degrees when both louvres are closed. The opposite end of each torsion bar fits into a square socket in the hinge pin (21) that passes through the outer lug, the square outer end of the pin fits into a hinge lug welded to the outlet louvre frame, and is retained by a Mills pin that passes through both pin and lug. The louvres are hinged together and their weight is counterbalanced by the torsion bars, therefore, only one louvre can be opened at a time.

6 The outlet louvre (14) is constructed in a similar manner to that employed on the inlet louvre; the major difference is that it has only two hinge lugs, and that the chevron louvre bars face to the rear. Both louvres extend to the full width of the compartment. A hole (19) machined in the left hinge lug of both inlet and outlet louvres and a captive locking pin (18) provide the method of locking the louvres in the open position. The locking pin is housed when not required in a bracket welded to the left hinge lug of the outlet louvre.

7 Four lifting handles, two per louvre to the outer corners, and a bracket (3) welded to the inlet louvre has mounted upon it a rubber pad (2) secured by a bolt and nut, and a spring-loaded catch (1). This bracket provides a stop for the driver's hatch door.

8 The locking catches (7), evenly spaced around the louvered doors, are located by pivot blocks (12) welded to the frame flange. The catch spindle (11) with integral locking tongue has machined flats that engage with a forked collar welded to the handle (9), the catch assembly is clamped in the locked position by a locknut (8). When released the catch is prevented from moving freely by a double coil spring washer (10), positioned between the block and tongue. A washer (13) peened to the end of the spindle prevents loss of the locknut.

Driver's hatch

9 The hatch (Fig 3) is an armour plate covering the opening of the driver's seat. The rear part is dished to give clearance for the driver's head when driving with the hatch closed and forward of the dish is an aperture to receive a periscope (2). Ten nuts are welded round the aperture for securing the periscope. The inside of the dish is lined with pads (6), (7) and (8) affixed with adhesive.

10 A landing strip (10) is welded all round the under edge of the plate, also a seal retainer (11) to secure a sponge rubber cored Linatex seal (1). After the seal has been inserted, the retainer sides are belt 20 deg towards each other to secure it. The hatch swings on a hinge pin fitted through two lugs on the roof plate and two lugs welded on the hatch. It is spring assisted in operation by a torsion spring, which is fitted round the hinge pin and located on it by a bush at each end. The spring is anchored at one end in a hole in the roof plate and, at the other, in one of the hinge lugs on the hatch. When closed, the hatch is secured by an internal rotatable locking handle (Fig 3 (9) and Fig 4), turning a spindle in a screwed bush in the hatch, so that as the handle is turned clockwise the hatch is clamped down. The handle is finished with a protective coating of Araldite. The spindle cannot be turned from outside the vehicle. Access to the closed down vehicle can be gained only via the rear door.

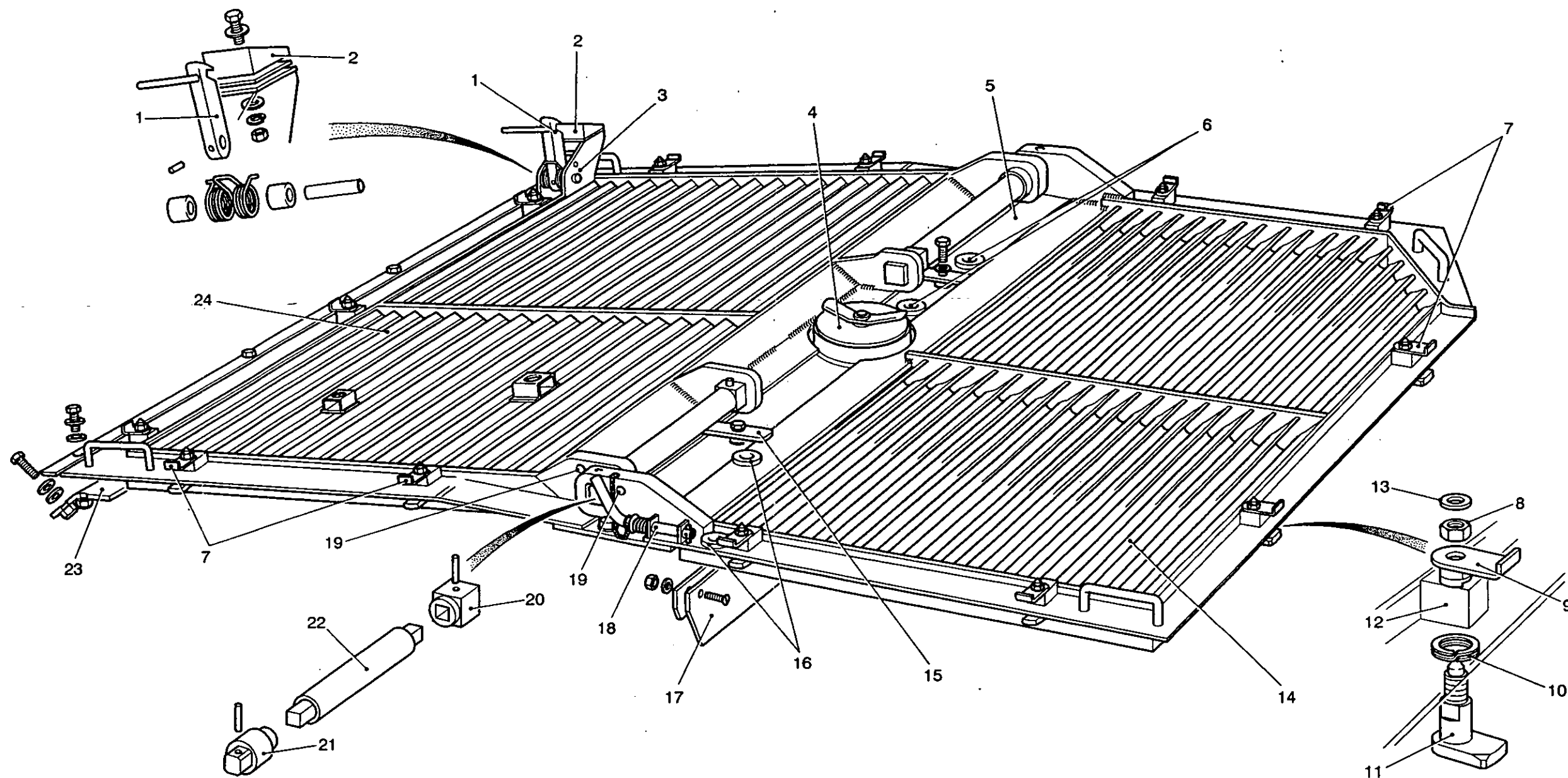

- | | | | | | | | |
|---|--|----|---------------|----|---------------------------------------|----|------------------|
| 1 | Spring loaded catch | 7 | Tumcatches | 13 | Washer | 19 | Locking hole |
| 2 | Rubber pad | 8 | Locknut | 14 | Outlet louvre | 20 | Attachment block |
| 3 | Driver's hatch stop bracket | 9 | Handle | 15 | Clamping plate | 21 | Hinge pin |
| 4 | Radiator filler cover | 10 | Spring washer | 16 | Boss, depression stop rail attachment | 22 | Torsion bar |
| 5 | Middle support | 11 | Catch spindle | 17 | Inlet deflector plate | 23 | Front support |
| 6 | Boss, barrel travelling clamp attachment | 12 | Pivot block | 18 | Locking pin | 24 | Inlet louvre |

Fig 2 Power pack compartment roof

432/297

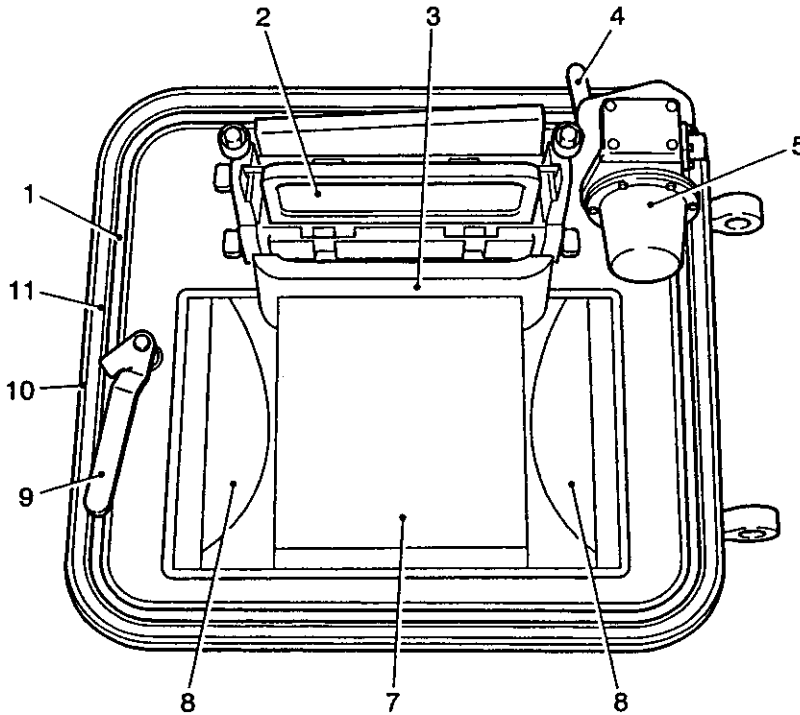

432/298

- | | | | |
|---|---------------------|----|----------------|
| 1 | Rubber seal | 7 | Head pad |
| 2 | Periscope | 8 | Head side pad |
| 3 | Brow pad | 9 | Locking handle |
| 4 | Screen wiper handle | 10 | Landing strip |
| 5 | Screen wiper motor | 11 | Seat retainer |
| 6 | Head side pad | | |

Fig 3 Driver's hatch

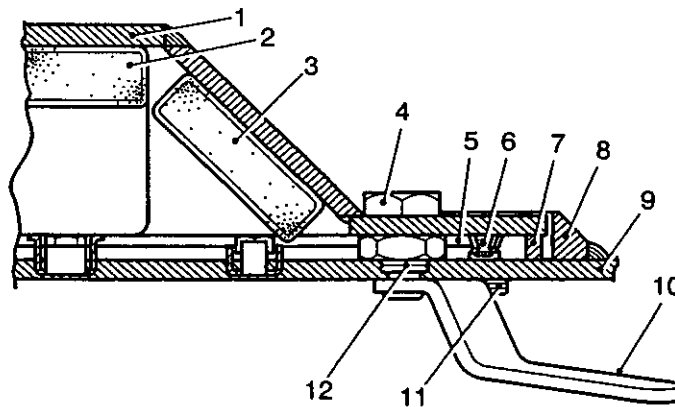

432/299

- | | | | |
|---|----------------------|----|------------------|
| 1 | Driver's hatch cover | 7 | Landing strip |
| 2 | Sponge rubber pad | 8 | Protecting strip |
| 3 | Sponge rubber pad | 9 | Roof plate |
| 4 | Fixed nut | 10 | Handle |
| 5 | Seal retaining strip | 11 | Catch |
| 6 | Seal | 12 | Clamping screw |

Fig 4 Typical hatch handle

Periscope washer

11 In the Mounting, Periscope, AFV, No. 2, Mk 1 is fitted a Driver's Periscope AFV, No. 33, Mk 1. Associated with it is a spring operated spray unit incorporating a three-hole bracket by which it is mounted on studs on the front sloping plate and secured by nuts and lock washers. Under two of the set bolts securing the spray unit to the reservoir is an upturned right angle outrigger bracket, a hole in which forms a support guide for a T ended operating handle which faces the driver's left hand. When the handle is pulled and released, a jet of water is forced through an orifice in a hexagon headed jet screwed into a special front centre periscope fixed bolt, which is drilled right through and tapped. The bolt is formed with a spigot terminating in a lip over which the water hose is fitted.

Periscope wiper

12 The driver's hatch cover hinge is on the left of the cover and parallel to the longitudinal centre line of the vehicle. The driver's periscope extends through a rectangular recess at the front of the cover.

13 The front of the periscope top outer glass is washed by the screen spray unit described in Para 11. Two 100 deg arcs are wiped by two wiper blades (Fig 5 (1) and (3)) that are electrically driven through a gearbox mounted to the left of the periscope on the underside of the hatch cover by three 7/16 in. countersunk hexagon headed screws.

Periscope Gearbox

14 The gearbox (Fig 5) is cast in aluminium alloy and provided with helicoil inserts for all screwed in items. It consists of a casing, (23) a front cover (37) secured to the casing by thirteen 4 BA x 7/8 in. cheese headed screws. The motor (17) which also acts as a rear centre cover, secured by six 2 BA x 1/2 in. cheese headed screws, an electrical three pin connector (24) secured to the bottom right side of the casing by four 6 BA x 3/8in. cheese headed screws, a terminal block at the base protected by a cover secured to the casing by four waisted screws, a switch (9) and interlock (see Para 32) at the top of the casing at the rear and an interlock housing (10) and cover (11) secured to the casing by four 6BA x 1/2in. cheese headed screws. Pins A and B in the terminal block are connected to the switch by internal cables. Pin C is not used. Behind the front cover is a bearing plate (34) located by two 5/32 in. x 9/16 in. stainless steel dowels (29) and secured to the casing by four 4 BA x 1/2 in. cheese headed screws. Two ball bearings (34) and (39) are located in the bearing plate, the lower being one of a pair carrying the first reduction gear (26). The upper supporting the forward end of the gearbox output shaft (38) which extends through the front cover in which is an oil seal (41) which seals the boss of a forked lever (42) keyed to the output shaft (Para 22).

15 The three gears driven by the motor all run in ball bearings positioned by circlips. The motor drives a gear mounted on a pinion shaft to which it is secured by a taper pin. This gear is supported by the bearings mentioned above at each end of a taper pin. This pinion drives a large gear (Fig 5 (27)) integral with a small one and a shaft supported by two bearings side by side. The small gear drives the output gear (30), which on one side has the crank pin (32) on which one end of the connecting rod (31) runs and on the other side has the supporting shaft, which is carried on two bearings.

16 The drive between the two periscope glass wipers (1) and (3) and the gearbox is via the forked lever (42) keyed (36) to the gearbox output shaft, two connectors (43) and (51) and two forked quadrants (48) pivoted (49) on a support (53) located by two 1/8 in. x 1/2 in. dowels and secured by two 2 BA x 1/2 in. countersunk headed screws to the periscope mounting bracket (45).

17 The connector (43) is fitted with an oil retaining bush at the end, which engages in the fork of the lever (42) in which it is pivoted on a pin secured by a split pin passed through it and one of the fork arms. The other end of the connector (43) is forked and connected similarly to the oil retaining bushed end of the connector (51). Each of two further similarly bushed holes in the connector (51) accommodates a pin passed through the forked end of each quadrant and secured by a split pin inserted through a hole in one of the fork arms. The quadrant arms remain parallel to one another at all times.

18 Each quadrant is provided with an oilite bearing and pivots on a pin (49) pressed into the support (53), the free end of which is located in a hole in the mounting bracket. The rear end of the hole is plugged with sealer.

19 The top end of each quadrant is formed into a segment in the periphery of which are cut teeth which engage with a gear on each wiper arm shaft which is carried in two oilite flanged bearings (5).

20 The forked lever (42) on the gearbox output shaft imparts a reciprocating movement to the connectors (43) and (51) which is transmitted to the wiper shafts gears via the quadrants. The lever (42) has attached to one of its form arms by three screws an extension which serves as a handle (40) for moving the blades in and out of the parked position or for operating them by hand should the need arise.

21 The output shaft (38) in the upper part of the gearbox is supported at the front by a journal ball bearing (39) and at the rear by two flanged oilite bushes (16) pressed into the casing rear wall one from the front and one from the rear so that their plain ends practically abut. Shaft thrust loads are taken by the two flanges one of which at the rear engages a thrust washer on the shaft while that at the front engages the face of the rearmost shaft collar (18).

22 The shaft has keyed to its front end the forked lever (42) mentioned in Para 17 which is caused to rock through an arc of 85 deg by a crank (22) mounted on the shaft driven through a connecting rod (31) the end of which engages with a crank pin (32) projecting from the side face of the driving gear (50).

23 The shaft assembly incorporates a ball type clutch, which is designed to unlock when torque of 6.8 to 7.9 Nm (60 to 72 lbf/in.) is applied. The shaft is some 127 mm (5 in.) long and has an integral flange (21) just over 51 mm (2 in.) from the keyed (36) end which is threaded 1/4 in. UNF - 2A. The other end is threaded 2 BA adjacent to a 1/4 in. squared section. The flange is 1.6in. in. diameter and provided with three equally spaced holes parallel to the shaft axis on a 33 mm (1.3 in.) diameter pitch circle. The periphery is cut at 90 deg to break into each hole. The holes in the flange accommodate three 7.9 mm (0.3125 in.) steel balls and the flange acts as the driven plate of the clutch.

24 Against the face of the flange facing the keyed end of the shaft is assembled the circular web of a crank (22). There are three holes, which match those in the flange except that their diameters are smaller 5.5 mm to 5.3 mm (0.215 in. to 0.209 in.) and chamfered to 45 deg on the face facing the flange to provide seating for the balls. This face is hard to provide a ball track. The crank may be of one piece with an induction hardened ball track or may have riveted to it a hardened steel ball plate. Either type has the same overall dimensions. In the two-piece type, the crank is not drilled, the seating being provided in the ball plate. The crank is a running fit on the shaft and is retained by a washer and circlip (33).

25 A centre pop mark (25) is made in the periphery of the shaft integral flange adjacent to one of the ball retaining holes. The crank pin hole has to be placed diametrically opposite to this centre pop marked hole to ensure correct assembly of the crank in relation to the shaft keyway.

26 Assembled from the squared end of the shaft is a case hardened flange (Fig 5 (15)) against which the balls can run when the clutch is disengaged. This is loaded by a spring (20) seated on the spigot of a collar (19) secured to the shaft by a taper pin. The spring is made from 12 SWG (0.104in.) wire, has a 9-1/4 turns and a free length of 51 mm (2 in.) When compressed to 28 mm and 25 mm (1.1 in. and 0.99 in.) it applies loads of 320 and 369 N (74 lbf and 83 lbf) respectively.

27 The squared end of the shaft carries an arm (13) secured on the square by a washer and self-locking nut. When the centre popped hole in the shaft integral flange is at to dead centre, two sides of the square are parallel to the vertical centre line through the hole flange and shaft, and the keyway at the other end of the shaft is at right angles to the centre line. The arm is 22 mm (1.3 in.) long with a boss drilled and broached to give an A/F dimension of 0.251 in. to 0.253in. and two sides of the hole about 30 deg off the centre line.

28 Although the crank is a running fit on the shaft it is not bushed because relative movement between crank and shaft occurs only when the wiper blades are being parked or un-parked or jammed by foreign material. All the time the wiper arms are working, there is no relative movement between crank and shaft, the parts being locked together by the clutch.

Clutch operation

29 When the motor is switched on, the reduction gears in the gearbox rotate. The crank pin (32) projecting from the side face of the output gear is linked by the connecting rod to a pin in the crank, and thus causes the crank to reciprocate. The crank acts as the driving plate of the clutch and transmits the drive through the balls seated in its face to the shaft integral flange in which the balls are retained and which acts as the driven plate. The spring-loaded flange (15) exerts sufficient pressure on the balls to keep them seated in their seats in the crank face until such time as sufficient unlocking torque is applied. This is done when the operator moves the handle to park the wiper blades. The handle, being keyed to the shaft, turns the shaft. The integral shaft flange turns with it and forces the balls to climb out of their seating on to the hardened crank face and against the hardened spring-loaded flange where they can roll freely to provide the disengaged condition.

30 The clutch will also disengage if some foreign body jams the wiper blades. The motor will not stall and the crank will continue to reciprocate on the shaft until the motor is switched off.

Interlock and switch

31 An interlock is provided to prevent the motor from being switched on while the wiper blades are in the parked position.

32 This consists of the arm (13) fitted on the squared rear end of the shaft described in Para 20 and a switch actuating slide (8). The latter consists of a piece of flat strip steel bent at right angles at one end to form a short handle or finger hold. In the longer portion is drilled a hole which when the item is assembled loosely encircles the handle (9) of a tumbler switch which controls the motor. The slide lies transversely with its handle to the right hand end at the back of the gearbox and is retained by a light cover (11). Pushing the handle to the left switches on the motor and pulling it to the right switches off the motor.

33 When the wipers are moved by the operator into the parked position the end of the arm (12) on the squared end of the shaft strikes the plain end of the slide and prevents it being moved to the left or switched on position. Thus, the motor cannot be switched on when the wipers are in the parked position.

Starting and stopping the wipers

34 Move the front handle (40) to bring the wipers into the operative position. Push the slide (8) to the left to switch on. To switch off, pull the slide to the right to stop the motor and use the front handle to park the blades.

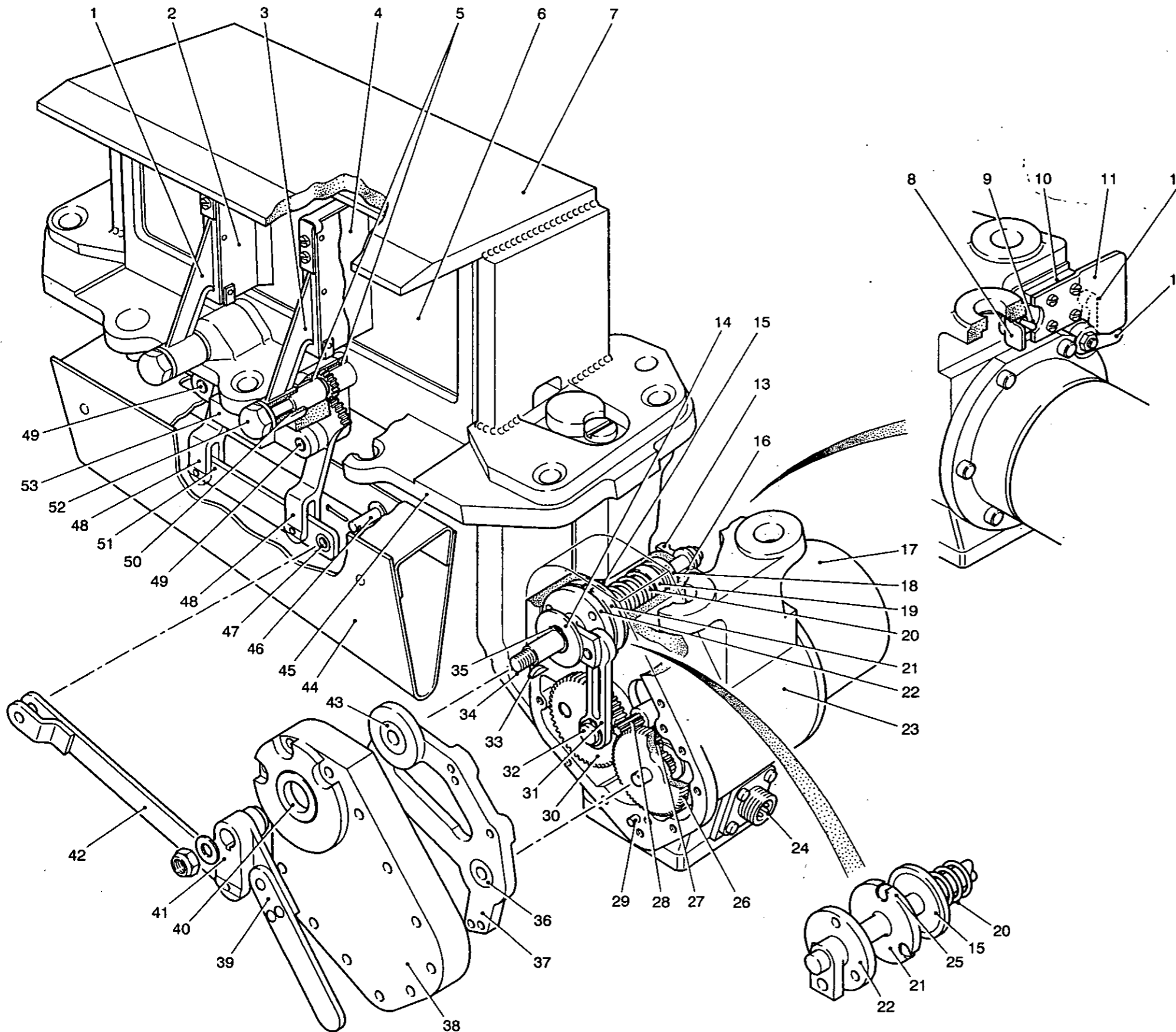

- 1 Right wiper arm
- 2 Wiper guard
- 3 Left wiper arm
- 4 Wiper rubber
- 5 Flanged oilite bushes
- 6 Periscope glass
- 7 Periscope guard
- 8 Switch actuating slide
- 9 Switch handle
- 10 Interlock housing
- 11 Interlock cover
- 12 "Switching off" position of (13)
- 13 Interlock arm
- 14 Washer
- 15 Hardened flange
- 16 Flanged oilite bushes
- 17 Motor
- 18 Shaft rear collar
- 19 Collar
- 20 Clutch spring
- 21 Shaft integral ball carrying flange
- 22 Crank
- 23 Gearbox casing
- 24 3 Pin connector
- 25 Centre pop mark
- 26 1st reduction gear
- 27 Intermediate gear
- 28 Motor pinion
- 29 Dowel
- 30 Output gear
- 31 Connecting rod
- 32 Crank pin
- 33 Circlip
- 34 Ball bearing
- 35 Bearing plate
- 36 Key
- 37 Front cover
- 38 Gearbox output shaft
- 39 Output shaft ball bearing
- 40 Handle
- 41 Oil seal
- 42 Forked lever
- 43 Connector
- 44 Guard
- 45 Mounting bracket
- 46 Pin and split pin
- 47 Oil retaining bearing
- 48 Forked quadrant
- 49 Quadrant pivot
- 50 Collet
- 51 Connector
- 52 Cap nut
- 53 Quadrant support

Fig 5 Periscope gearbox

Mortar hatch

NOTE

The roof mounted equipment basket and lighting brackets for the Bowman radio equipment, stop the mortar hatch from being opened and restrict rescue capability.

35 The mortar hatch (Fig 6) comprises two semi-circular doors in the roof plates over the personnel compartment. Each is made up of two sections, the inner sections (9) and (12) folding back over the outer sections (6) and (13) and the two sections folding back over the roof plates. When closed, the door is clamped by six handles (22) two on each outer section and two on the right inner section, which overlaps and clamps the left inner section. The clamping section is similar to that shown in (Fig 4), it is also used on the cupola (Fig 8), and is obtained by the screwed spindle on the locking handle turning in a screwed bush, which is secured in the door. The direction of turning depends on whether LH or RH threaded components are fitted. RH threaded handles are fitted at the rear of the left outer section and at the front of the right inner and outer sections. LH threaded handles are fitted at the front of the left outer section and at the rear of the right inner and outer sections. A light torsion spring is fitted round each locking handle spindle to stop the handle swinging and impeding the closing of the door. The handles are finished with a coating of Araldite.

36 The doors are clamped down onto a sealing ring (Fig 6(11)) in a circular landing ring, which surrounds the hatchway. Along the inner edges of the outer sections are welded seal retaining strips (14) an edge of which is bent up to retain the seal (15). The action of the hinges is such that, on closing, the inner sections overlap the outer sections and compress the seal. A similar arrangement (7) and (8) seals the join between the inner edges of the inner sections, the right section over-lapping the left. Additional foam rubber sections (21) are applied by adhesive to the straight seals (15) along the section joints.

37 The weight of the doors is countered by laminated torsion bars. The movement of each inner section (9) and (13) is assisted by two torsion bars (2) and (3) anchored at their inner ends in a bracket welded on the section and at the front and rear in the hinges screwed to the outer section. The torsion bar (1) and (4) assisting the movement of both inner and outer sections is a double acting one, being anchored at each end in a hinge and anchored at the middle in a block welded to the roof plate. Each torsion bar is encased in a tube and comprises eight spring steel strips, which are loaded by being turned 90 deg when the door is closed.

38 When the inner section is swung back, it comes against a rubber stop on the outer section where it is retained by a spring catch (5) engaging a loop (10) on the top section. When each double section is swung back, the outer section comes against a rubber stop, bolted on the roof plate, and the assembly is retained by a spring catch engaging a loop (23) on the interior face of the inner section.

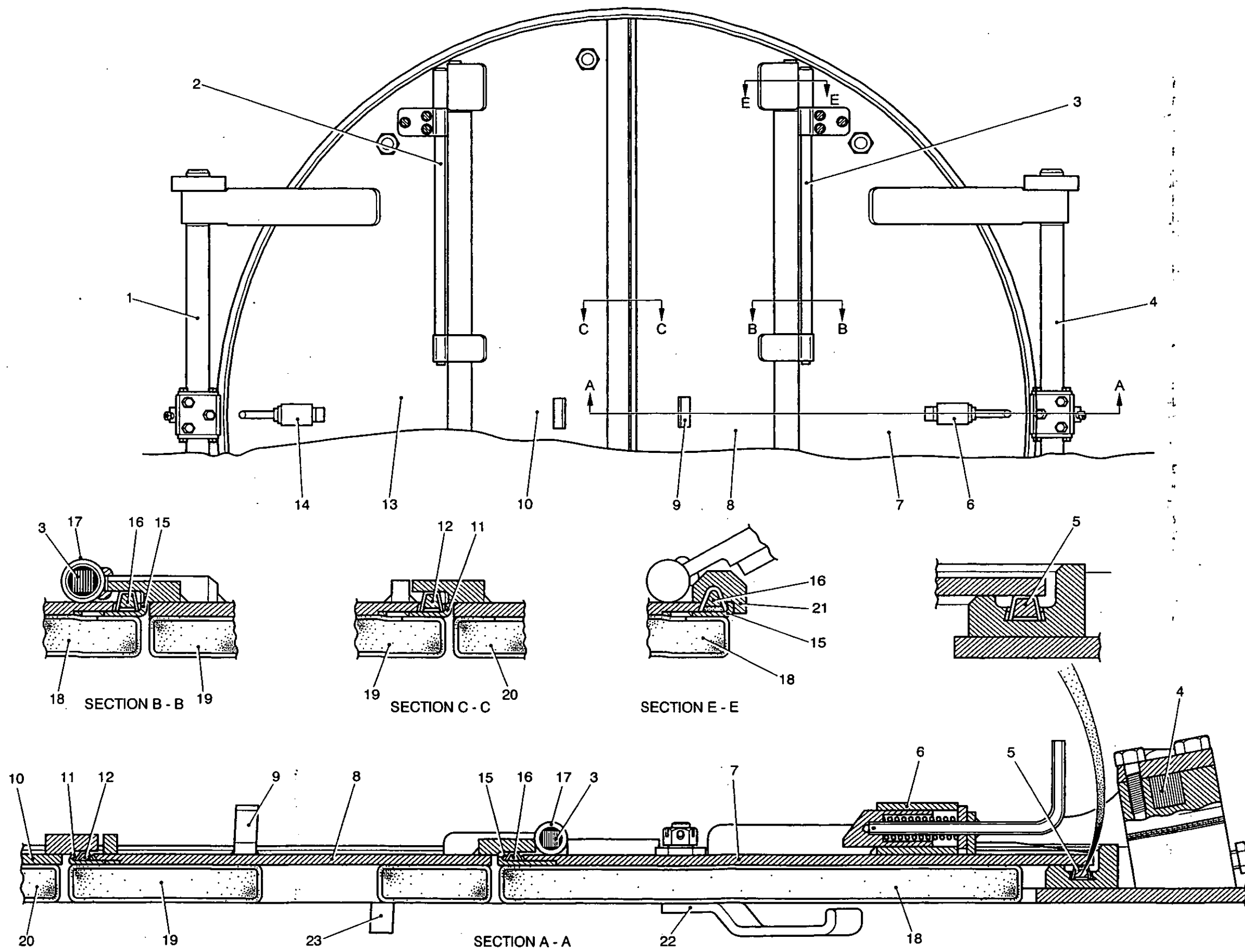

- 1 Torsion bar
- 2 Torsion bar
- 3 Torsion bar
- 4 Torsion bar
- 5 Catch assembly
- 6 Left outer quarter door
- 7 Seal retainer
- 8 Linatex seal
- 9 Left inner quarter door
- 10 Loop
- 11 Linatex seal
- 12 Right inner quarter door
- 13 Right outer quarter door
- 14 Seal retainer
- 15 Linatex seal
- 16 Catch assembly
- 17 Torsion bar tube
- 18 Sponge rubber pad
- 19 Sponge rubber pad
- 20 Sponge rubber pad
- 21 Sponge rubber pad
- 22 Clamping handle
- 23 Loop

Fig 6 Mortar hatch

Commander's cupola

39 The cupola comprises a fixed ring, (Fig 7 (18)) and a rotatable top ring incorporating a door (5). The assembly is bolted to a locating ring welded to the roof plate. Internally the fixed ring is machined to form a track for three rollers (26) on which the rotating ring rotates, and is faced to form a track for four centering rollers (4).

40 The rotating ring has an elliptical hole for the door, and welded to the top is a fabricated guard for a group of three periscopes. A socket (15) and locking pin for the MG mounting pintle is on the top of the guard. Opposite the guard are welded two pairs of lugs for the hatch door hinges.

41 Rubber seals (10) and (6) are fitted to the fixed ring and the underside of the cupola door to make an effective seal when the vehicle is closed down.

42 The traversing rollers (26) are mounted on eccentric shafts supported in blocks welded to the underside of the rotating ring. The shaft is rotated by means of a handle (24) secured by a Mills pin, and is held in either a locked or free position by a spring loaded ball. When the handle is rotated, the roller bears against the top of its groove and forces the rotating ring into contact with the rubber seal (17) thus sealing the cupola at this point. When sealed the cupola is locked and cannot be traversed.

43 The four centering rollers run on oil retaining bushes round a centering ring. The ring is clamped by a wedge lock screw fitted in a boss welded to the top plate. A washer fitted under the screw head retains the roller and bush.

44 The cupola door is a flat plate hinged to the lugs on the rotating ring. A head pad is attached to the underside of the door. The door when closed is secured by two rotatable handles (7), which engage with the underside of the rotating ring. The handles are attached to threaded spindles which turn in bushes screwed through the door and secured with locknuts so that when the handles are turned the door can be clamped down on the seal (6). For ease of operation one spindle has a RH thread and the other a LH thread. When released the handles are retained in the open position by wire torsion springs. The door can only be opened or closed from inside the vehicle. When opened it is stopped by a rubber buffer and retained by a spring-loaded catch (3) incorporated in one of the hinge assemblies. The catch is released by lifting the handle welded to it.

Periscopes and wiper

45 Three mountings for the periscopes AFV No. 32 Mk 1 are provided; the two outer mountings being fixed, of which the LH periscope is fitted with a manual wiper. The centre mounting (Fig 7(16)) has a trunnion type bearing which enables it to have a limited movement in the vertical plane. The centre mounting is restrained from freely swinging by two friction plates, which have a double coil spring washer to apply pressure, attached to the periscopes housing. To restrict the swing of the periscope a restraining plate has been added to the assembly. AESP 2350-T-251-811 Mod Instr No 1/63 refers. Each periscope mounting has an attached 'U' frame (20) fitted with a brow pad (21) and a knurled screw (19) to secure the periscope in its mounting, the two outer 'U' frames have extensions (22) which serve as handles for the purpose of traversing the cupola.

46 A flat plate with a laminated glass window (13) and a manually operated single wiper arm (9) attached is screwed to the LH periscope. A flexible cable (14) with a knob (23) screwed to the lower end, passes up through the rotating ring adjacent to the left periscope mounting and connects with the wiper arm-actuating lever (8). A pull on the flexible cable draws the wiper arm across the window and a wire torsion spring acting on the actuating lever provides the return action when the flexible cable is released.

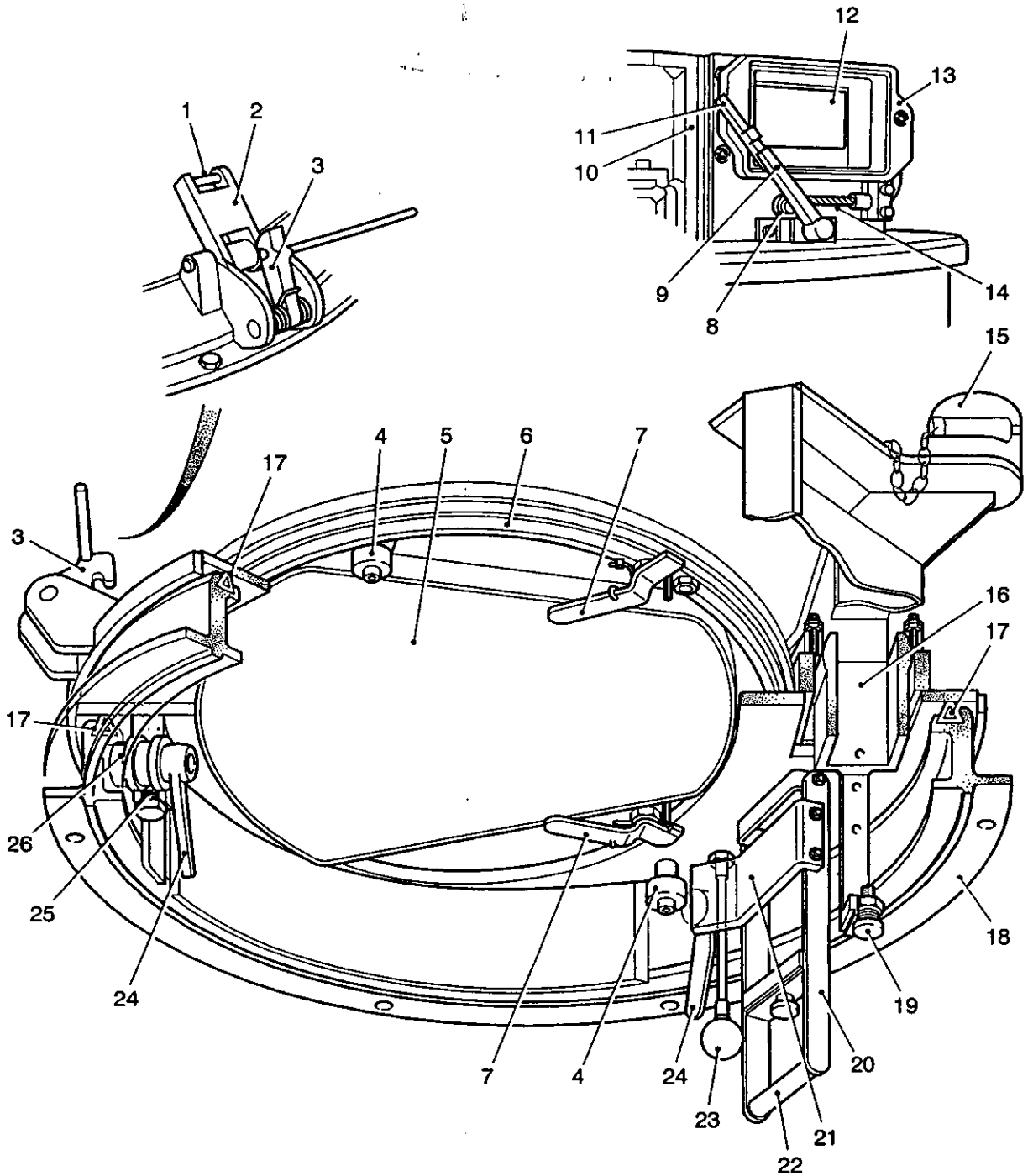

432/303

- | | | | | | |
|---|-------------------|----|----------------------------|----|------------------------|
| 1 | Catch pin | 10 | Periscope guard | 19 | Knurled screw |
| 2 | Door hinge | 11 | Wiper blade | 20 | 'U' frame |
| 3 | Door catch | 12 | Periscope | 21 | Brow pad |
| 4 | Centering rollers | 13 | Window plate | 22 | Traversing handle |
| 5 | Door | 14 | Flexible cable | 23 | Wiper operating handle |
| 6 | Door seal | 15 | MG socket | 24 | Cupola locking handle |
| 7 | Door handles | 16 | Movable periscope mounting | 25 | Detent spring |
| 8 | Actuating lever | 17 | Cupola seal | 26 | Traverse roller |
| 9 | Wiper arm | 18 | Fixed ring | | |

Fig 7 Commander's cupola

Rear door

47 The rectangular armour plate door is hung from two external welded hinges; the headed hinge pins are retained by slotted nuts with split pins. A landing strip welded around the inner face of the door has a 'Linatex' door seal adjacent to it, affixed with adhesive, and retained by a securing strip tack welded to the door. The external locking handle with integral shaft is mounted in a bush welded to a machined hole in the door; the handle shaft is sealed by an internal 'O' ring. The inside handle is mounted on the protruding shaft and engages with its square end and is retained by a slotted nut with split pin. Twin spring-loaded detent balls are mounted in holes drilled in the handle body, the balls engage with depressions machined in the face of the mounting bush, so placed as to retain with handle in the open position. The short leg of the handle engages with a shimmed latch block secured to the hull plate, that enables the door to be clamped shut. Five additional swivel clamps are provided to the inner face of the door, to give a higher degree of sealing when the vehicle is required to float. Padlock hasps are provided to enable the vehicle to be secure, as both the commander's and driver's hatches are locked by clamps from inside, the rear door is the main mode of entry when the vehicle is 'closed down'.

48 A strut hinged by a staple welded to the inner side of the door and housed in a bolted clip, is used when required to hold the door in the open position by the engagement of its hooked end with a staple welded to the splash strip which is welded around the door aperture. An electrical contact box mounted on the inside of the rear plate has spring plungers that contact (when the door is closed) plates mounted on the rear door. The contact plates are connected by armoured cables to the registration plate and convoy lights positioned on the door outer face. The registration plate with attached light is mounted on studs welded to the outside of the door, and has adjacent to it two quick-release brackets that house two portable fire extinguishers in a vertical position. The inner face of the door is covered with a plastic covered foam rubber pad affixed with adhesive, and a first aid box stowage bracket positioned above the convoy light connection, with its securing bolts passing through the rubber pad. A bracket attached to the top right side of door makes contact with the blackout switch secured to the vehicle rear plate. A laminated glass window has been provided to give rearward vision from the personnel compartment. The vision block assembly bolted through a rectangular hole machined in the doorplate to the left of the registration number plate is sealed by a gasket interposed between the block flange and doorplate. The laminated glass block is sealed in its casing and has a blackout blind fitted to its inner side which has two coil springs that hold the blind in the open or closed position.

Dischargers, smoke grenade, No. 8, Mk 1

49 The dischargers (Fig 8) are mounted at the front of the vehicle, one on each side, and are used for laying down a defensive smoke screen. They have a fixed range of approximately 64 m (70 yards). The grenade used is the Grenade, Smoke, Screening, L5A1, fitted with fuze, electric 3 inch No. 53, Mk 1. A minimum current of 0.9 A is required to operate the fuse.

50 Each discharger comprises three barrels incorporated in a single casting, forming a triangle and the barrels are splayed laterally to give a spread of 40 deg. The bottom of each barrel contains a drain hole for the escape of any water, which may enter the barrel.

51 The base of each barrel is drilled and tapped for the reception of the firing mechanism which consists of firing pin with a screwed nipple on the end for the attachment of the positive electric lead, a threaded adaptor which screws onto the adaptor

52 Enclosed in the base of the casting are the resistances (Fig 8 (3)) in each circuit with a connector for the electric supply cable.

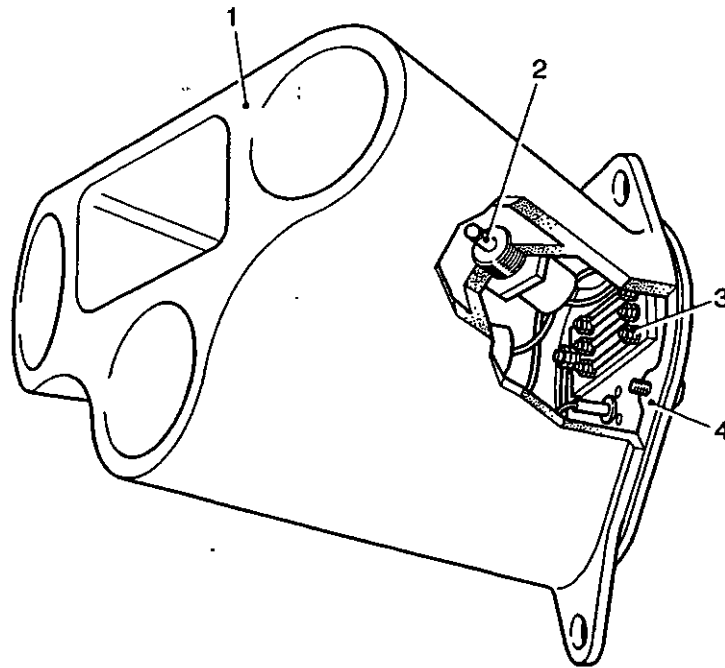

432/304

- | | |
|--|-------------------------------------|
| <p>1 Barrel casting
2 Firing pin</p> | <p>3 Resistance
4 End cover</p> |
|--|-------------------------------------|

Fig 8 Discharger, smoke grenade, No. 8, Mk 1

Driver's seat

53 Eleven fore and aft seat settings (range, over 203 mm (8 in.)), six height settings (range, 222 mm (8.75 in.)) and six backrest inclination settings (range, vertical to horizontal) are provided in the driver's seat assembly (Fig 9). The bottom of the backrest support (2) is mounted on links (4) which permit the backrest to be set 51 mm (2 in.) forward of the rearmost position; in either position the six squab inclination settings are available. A driver's harness is provided.

54 Four brackets (34) welded to the hull, support the seat mountings and two more support the free end of the commander's chequer plate footrest (7) which is hinged (42) to the rear of the seat frame and maintained in a horizontal position, in contact with its support brackets, by an over-centre spring which also holds it vertical when required.

55 The base for the seat is a fabricated frame consisting of a transverse inverted channel at the rear and a hinged angle at the front to the inner side of which are welded two longitudinals. The hinged angle is connected to a fixed angle by a hinge (33) at each end. Two flat support strips are placed on the longitudinals and on each of these is a floor rack rail (28). Bolts through the ends of the transverse members hold down the base onto the support brackets. Removal of the rear fixing bolts permits the seat to be tipped forwards on its hinges.

56 The rack rails (28) are of channel section with the flanges bent inwards to form retaining guides for the seat slides. Eleven rectangular holes are cut on the centre line towards the front of each rail to form the rack, which permits fore and aft seat adjustment. Two catch levers (27) and (32) engage with the rack holes and are joined by an operating bar (35) across the front of the seat.

57 Mounted in the floor frame are a hand lever (40) and rod which extends across the frame and has fitted at each end a fabricated height adjusting lever (30) and (37) which is maintained in position on the rod by two pins which pass through the lever bosses and the rod. At the other end of each lever is a hole in which is inserted a shouldered pin (39) which protrudes on the outer side of the lever. A spring (29) encircles each lever boss; one end presses down the lever and the other reacts on the rack rail. At the front of the frame is centrally anchored a 20 leaf square sectioned torsion bar (31) which lifts the seat when the hand lever is operated.

58 In the sliding anchor rails run two sliding anchor racks, with lips which engage with the guides in the anchor rails, to which the rear end of the inner cross lever assembly (8 and 41) is pivoted. The front ends of these cross levers are pivoted in sliding anchors, lips on which engage with runners on the underside of the seat frame and their centres are spaced by a tube arc welded to them. The rear ends are spaced by a tube.

59 A torsion bar (43), which is inserted through the tube joining the centres of the inner cross levers joins the outer cross levers centre bosses in which it is secured by pins. The front ends of the outer cross levers are fitted with threaded pivot pins and have welded to them square sockets in which ends of the laminated torsion bar (32) are accommodated. The pivot pins secure the front ends of the levers to pivot plates held to the frame by two studs, which are prevented from becoming loose, by a locking plate, which is turned up to secured them. The rear-ends of the cross levers are pivoted to the rear of the seat frame.

60 The squab frame is pivoted on two throw-over links (1) mounted on a torsion tube at the rear of the seat frame. To each pivot bolt is also attached a link (5) the other end of which is coupled to the bottom of a backrest stay (4), the movement of which is constrained by a slotted plate (6). When the throw-over link is actuated to move the squab bodily backwards or forwards the link and pin connecting the squab stay move along the slot too and maintain the squab angle setting.

61 Centrally mounted in the backrest frame is a vertical rack (25) with its edges turned over so that it can slide in a similarly shaped carrier plate embodying two links to which the upper ends of the squab stays are attached. A transverse locking bar (14) operates a trigger (23) to disengage the rack for squab inclination adjustment.

Seat harness

62 The harness is fitted to the backrest and roof. Connected to a quick-release buckle (20) are a two piece waistband (12) and two shoulder straps (17).

63 Each half of the waistband terminates in a slotted plate (6) through which the band is passed, turned over and sewn. The plate is anchored on a lug on the backrest by a bolt and nut and a countersunk screw (10).

64 Each shoulder strap terminates in a slotted hook plate through which the strap is passed, turned over and sewn. The hook (15) is of the snap type and engages with an eye welded to the roof. The two straps are joined by a horizontal fabric brace (16) near the hooked end.

65 Each shoulder strap is in two parts, joined by an adjusting buckle (18), which permits the length of the lower part to be varied. Buckle lift tabs (19) are provided.

66 The quick-release buckle (20) provides fixing points for the lower parts of the shoulder straps and for the loops in the ends of the adjustable waistband. The word 'LIFT' is marked on the buckle handle (21). When the harness is released, the waistband parts and the shoulder straps move clear with the two halves of the buckle to which they remain attached.

67 The free ends of the adjustable straps are accommodated in retaining tabs (11) stitched onto the straps. The tabs are passed round the strap ends and secured by dot fasteners.

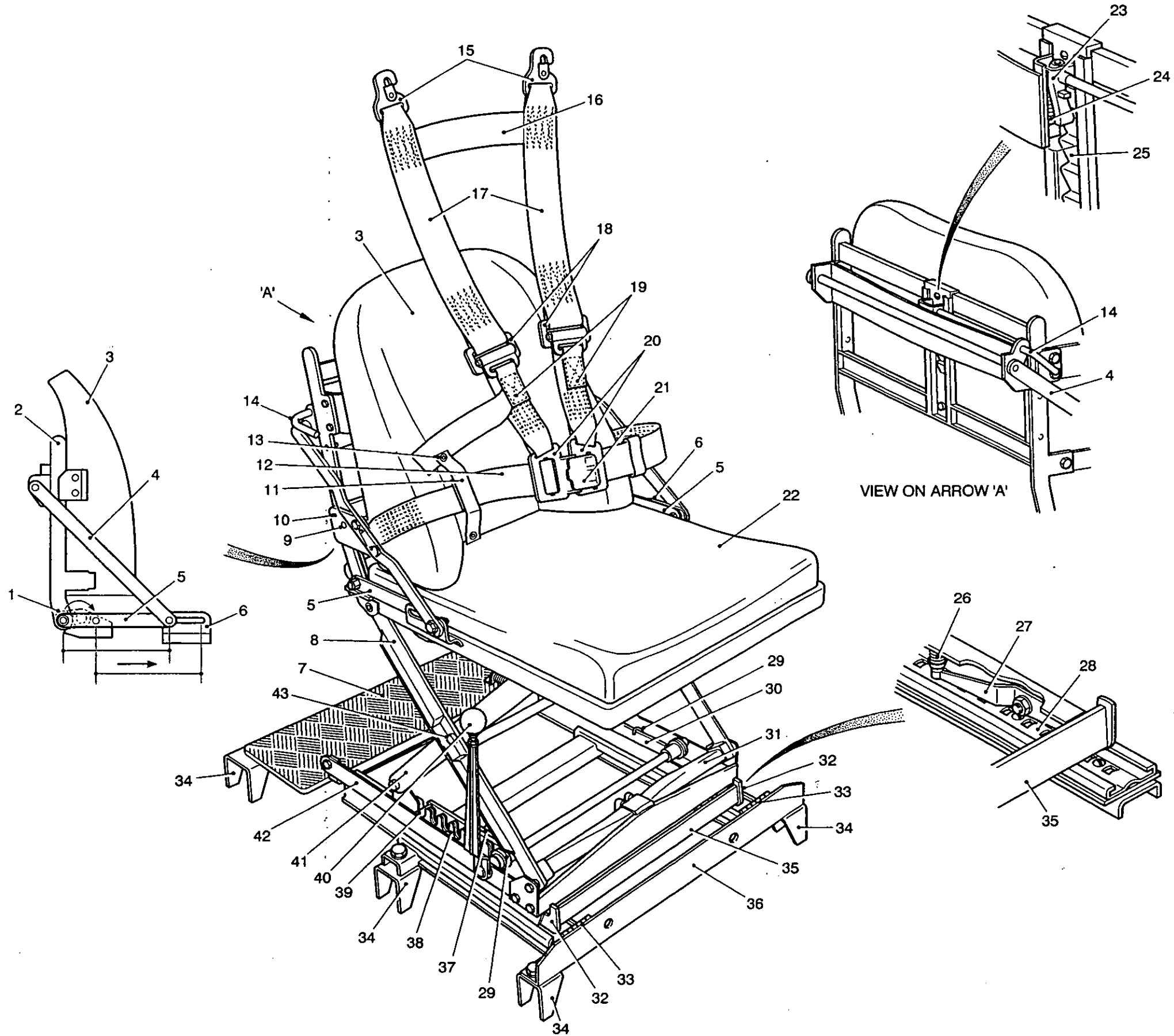

- 1 Backrest fore and aft throw-over adjuster link
- 2 Backrest support
- 3 Backrest squab
- 4 Backrest stay
- 5 Link connecting (2) and (4)
- 6 Slotted plate
- 7 Commander's footrest
- 8 Right cross lever assembly
- 9 Slotted plate
- 10 Countersunk screw
- 11 Retaining tab
- 12 Waistband
- 13 Dot fastener
- 14 Backrest inclination adjustment locking bar
- 15 Snap hooks
- 16 Brace
- 17 Shoulder strap
- 18 Shoulder strap adjusting buckle
- 19 Lift tab
- 20 Quick-release adjusting buckles
- 21 Quick-release handle
- 22 Seat squab
- 23 Trigger
- 24 Trigger spring
- 25 Rack
- 26 Spring
- 27 Fore and aft adjustment catch lever, right
- 28 Rack rail, fore and aft seat adjustment
- 29 Height adjusting lever spring
- 30 Height adjusting lever, left coupled to (25)
- 31 Laminated torsion bar
- 32 Fore and aft adjustment catch lever, left
- 33 Hinge
- 34 Hull mounting bracket
- 35 Fore and aft adjustment operating bar
- 36 Seat front support angle
- 37 Height adjusting lever, right, coupled to (12)
- 38 Sliding anchor rack
- 39 Shouldered pin
- 40 Seat height adjustment handle
- 41 Right cross lever assembly
- 42 Commander's footrest hinge
- 43 Torsion bar connecting right and left cross lever

Fig 9 Driver's seat

Commander's seat

68 The seat (Fig 10) comprises the seat pan (2) and backrest assembly, which is attached to a carrier (17) held in a roller track assembly (16) bolted to the lower right sideplate in the driving compartment.

69 The roller track assembly is a welded sheet metal construction, built up on a backplate and forming an open fronted box. The backplate acts as a track for two rollers on the carrier on which it is moved up or down in the assembly. The carrier, also of sheet metal construction, is clamped in position by a hand-wheel (19) which turns an eccentric (14) operating through the open front and tightens a cross bar (20) against the inside face of the roller track assembly.

70 Across the backplate of the roller track assembly are welded five stops or rack teeth. At the bottom of the carrier, assembly is a single tooth (15). All are so shaped that loading tends to increase the engagement of the single tooth with any given rack tooth. Those teeth provide a range of seat height adjustment of approximately 10 inches. Two transverse pegs (18) in the carrier prevent it from parting from the roller track assembly but are given sufficient clearance to permit disengagement of the single tooth from the rack tooth when the clamping wheel is loosened.

71 The seat pan is welded to an arm, at right angles to the centre line of the vehicle, which is attached to the carrier by a hinge bolt (23) fitted through two lugs welded to the arm. The end of the arm abuts the face of the carrier so that the seat is held horizontal. The backrest support (3) is also welded to the pan and extends rearwards. A vertical collar (12) is welded to it. Another collar (13) is hinged (10) to the same support. Both collars are bored, the fixed one having an internal chamfer (9) at the top. The hinge is so designed that when closed the hinged collar rests on top of the fixed one and their bores align to receive a chamfered spigot (11) at the bottom of the tube (7) to which the backrest is fitted. Both collars are slotted to allow a retaining pin in the tube spigot (11) to pass through them until halted by a collar (8) on the backrest tube.

72 The slots in the collars are at right angles to one another so that the backrest cannot unintentionally be withdrawn completely. To park the seat and allow a free passage along the compartment the backrest is first lifted clear of the lower collar and then swung underneath the seat. The seat is then swung upwards on its hinge to a vertical position, where it is locked by a spring-loaded plunger mounted on the seat support, which engages with a hole drilled in a plate welded to the carrier.

~~UNRESTRICTED~~

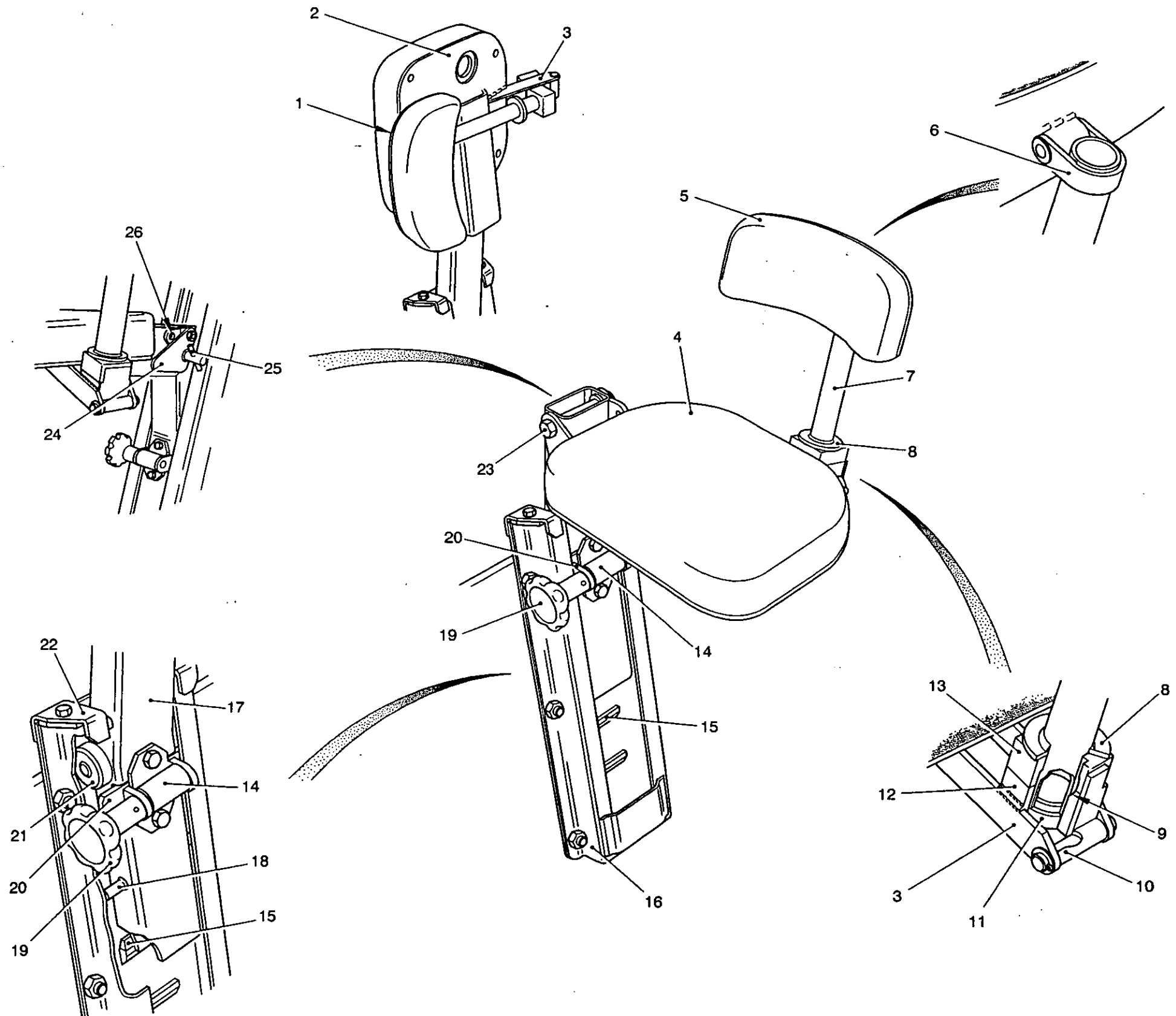

- 1 Backrest pan
- 2 Seat pan
- 3 Backrest squab
- 4 Seat squab
- 5 Backrest squab
- 6 Backrest pan attachment to (7)
- 7 Backrest tube
- 8 Collar
- 9 Internal chamfer in (12)
- 10 Hinge
- 11 Chamfered spigot
- 12 Fixed collar
- 13 Hinged collar
- 14 Eccentric
- 15 Carrier tooth
- 16 Roller track assembly
- 17 Carrier
- 18 Peg
- 19 Handwheel
- 20 Crossbar
- 21 Roller
- 22 Stop
- 23 Hinge bolt
- 24 Seat support
- 25 Locking plunger
- 26 Hole

Fig 10 Commander's seat

~~UNRESTRICTED~~

Personnel seats

73 Two seats (Fig 11) are arranged along RH side of the Command staff compartment, each consisting of a sheet metal tray (3) supported by two brackets (4) which hinge (5) on brackets bolted to the hull lower sideplates (1). The end of the tray supporting bracket (4) abuts the sideplates to position the seats in the lowered position. In the raised position, the seats are held by a double link (6), which moves over-centre against the sideplates. The seat squabs are secured to the trays by wood screws.

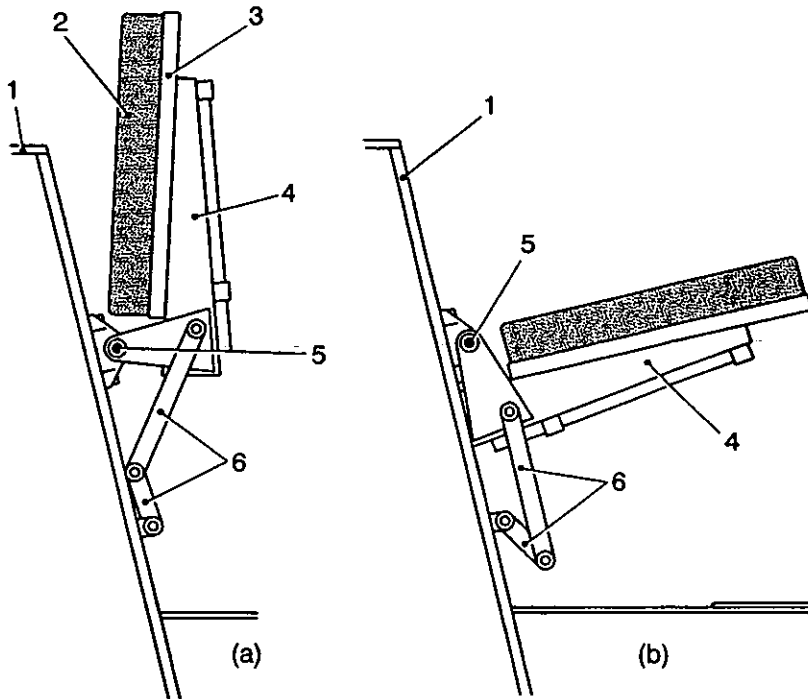

- 1 Hull lower sideplate
2 Seat
3 Tray
(a) Seat stowed

- 4 Tray support bracket
5 Hinge
6 Double link
(b) Seat lowered

432/307

Fig 11 Personnel seats

Sliding table assemblies

74 The Command staff compartment is equipped with two sliding table assemblies one for the Staff Officer and one for an operator, each of which provides a platform for retaining the Dismountable User Data Terminals (DUDT). Each sliding table can be secured in the extended or retracted position. A map board is suspended from the vehicle roof, at the rearmost station, with its free end support by a tray at the rear of the sliding table assembly. The map board can act as a mounting platform for electronic large display panel, which is stowed internally within the vehicle.

Weapon stowage

75 The commander's and driver's personal weapons are mounted on the internal engine cover, behind the driver, in stowage brackets. One set of brackets facing forward and the facing rearward. Each set of brackets comprises a butt rest and a barrel retaining clamp. Command staff personal weapons are stowed in brackets mounted on the rear door.

FIRE FIGHTING EQUIPMENT

76 Three types of fire fighting equipment are provided on the vehicle, two portable types, and a fixed type.

77 The portable types of fire fighting equipment are BCF and dry powder and both are expendable. Once the striker head has been operated, the extinguisher completely empties itself and the container should be discarded.

78 The three dry powder extinguishers are painted green and are carried on the outside of the vehicle in quick release brackets, one on the sloping plated at the front of the power pack and two on the rear door.

79 The two BCF extinguishers are painted red and are carried in the inside of the vehicle, one in the driver's compartment on the power pack compartment plate and the other in the personnel compartment on the power pack partition rear plate.

80 The fixed equipment (Fig 12) comprises two cylinders (9) each containing 2.3 ltrs (0.5 gall) of liquid FM200 which discharges as a gas. Both cylinders are mounted vertically side by side on a bracket (13) welded to the transverse bulkhead above the left track guard sill, in the personnel compartment, a securing plate (6) with twin caps fit over the tops of the cylinders and clamps the cylinders by means of two tie bars (8) to the mounting bracket. The discharge head (10) is at the bottom, (as mounted), of each cylinder and a test diaphragm (7) is located on the top. The securing plate is cut away to give access to the contents indicator gauge, if the indicator is outside the green range, the cylinder must be renewed.

81 Each discharge head has a captive screwed plastic plug (14) provided to cover the high rate discharge port if for any reason the cylinder has to be removed when full. The outlet from each discharge head is connected by copper tubing (18) which is routed forward through the bulkhead via a connector into the power pack compartment, clips attach the tubing (19) to the compartment side plates and flexible hoses (20) connect the copper tubing with drilled spray pipes (4) secured to the power pack frame by clips. The flexible hoses are disconnected from the spray pipes (21) when the power pack is to be removed from the vehicle.

82 Either cylinder can be discharged by operating the finger bars (16) on the discharge heads or by remote control. The finger bars can be operated directly or remotely by controls in the driver's compartment and on the outside of the vehicle. The controls in the driver's compartment are two turn and pull handles (2) which are connected via a control cable junction box (17), one to each cylinder trigger, by Bowden cable. The two outside controls (1 and 5) are similar and located one on each side of the vehicle, inset midway along the side plate. Each handle is connected by Bowden cable via the junction box with one cylinder, the cable connecting with the cable from driver's compartment so that both cables use a common attachment to the trigger.

NOTE

The rate of discharge cannot be controlled, once the discharge starts, the cylinder will empty totally.

Fire alarm system

83 The fire alarm system is operated electrically and is designed to give a visible and audible warning of overheat or fire in the power pack or steering unit compartments. It will not give a warning if a short circuit occurs or if a fault develops, in the power supply or control unit. Therefore, it is essential that the system be tested regularly.

84 It employs a continuous type detector (sensing element loop) and will automatically reset. The loop consists of three interconnecting sections located on the cooling fan cowling, power pack frame and in the steering unit compartment; the sections are secured by clips.

85 The crew warning system, comprising two flashing warning lights which have red lenses, located one in front of the driver's position, the other centrally at the top front of the personnel compartment. A warning horn is also provided, being positioned below the driver's switchboard. The detectors are also connected to the intercommunication system, which causes a buzz to be heard in all connected headsets. A test switch is provided for checking the system.

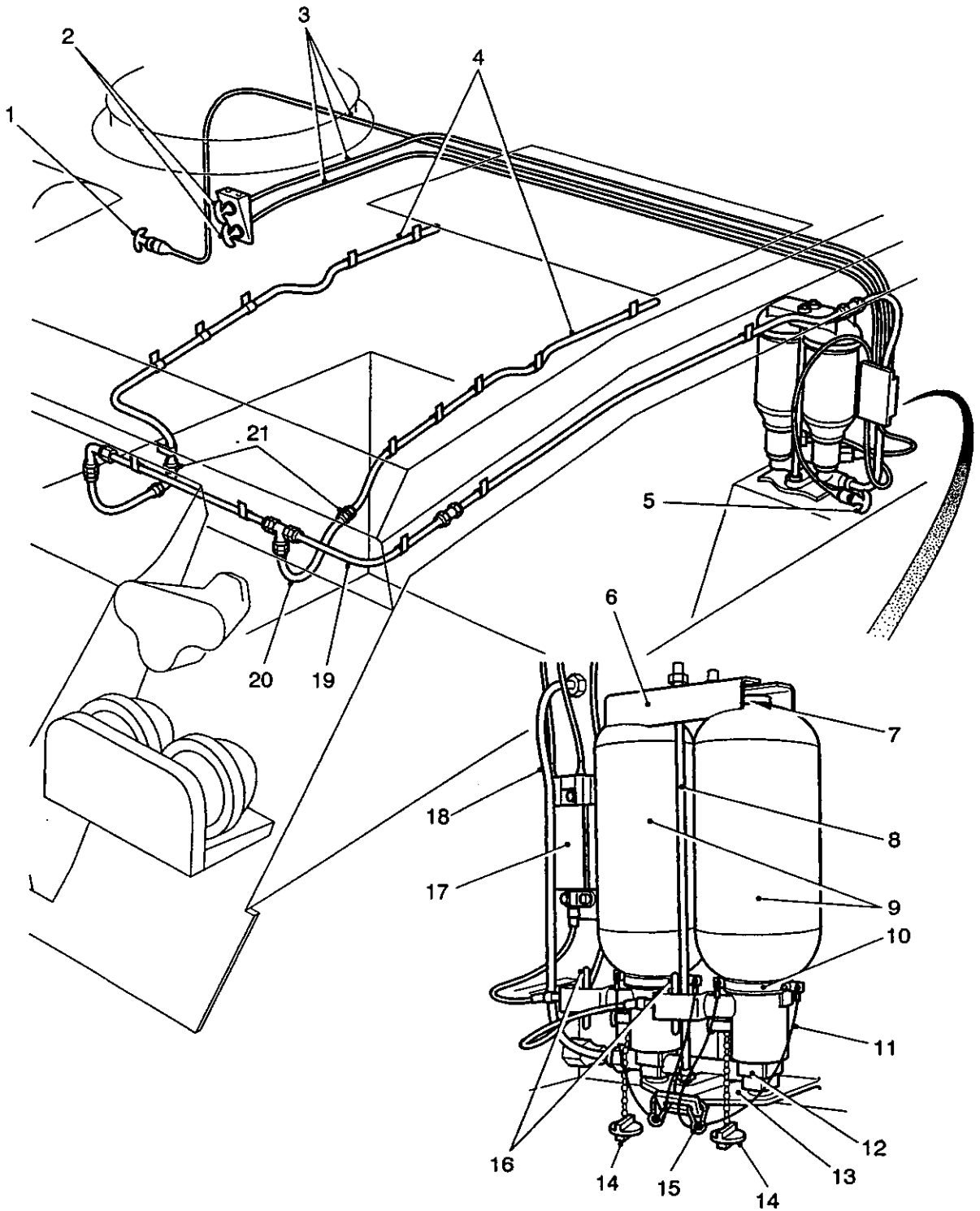

432/271a

- | | | | | | |
|---|-------------------------------------|----|----------------|----|---------------------|
| 1 | Right external turn and pull handle | 7 | Test diaphragm | 15 | Clip |
| 2 | Driver's turn and pull handles | 8 | Tie bar | 16 | Finger bars |
| 3 | Bowden cable | 9 | BCF cylinders | 17 | Cables junction box |
| 4 | Spray pipes | 10 | Clamp | 18 | Copper tubing |
| 5 | Left external turn and pull handle | 11 | Safety Cable | 19 | Tubing |
| 6 | Securing plate | 12 | Discharge head | 20 | Flexible hoses |
| | | 13 | Bracket | 21 | Disconnect points |
| | | 14 | Plastic plug | | |

Fig 12 Fixed fire fighting equipment

HOIST UNIT

86 An AFV hoist unit has an external stowage location on brackets, welded to the armoured housing, situated on the LH side of the vehicle roof (Fig 13). The hoist unit has a lifting capacity of 250 kg (550 lbs) with a maximum reach of one metre (3.3 ft) and is used to lift and lower roof mounted generators in field operations.

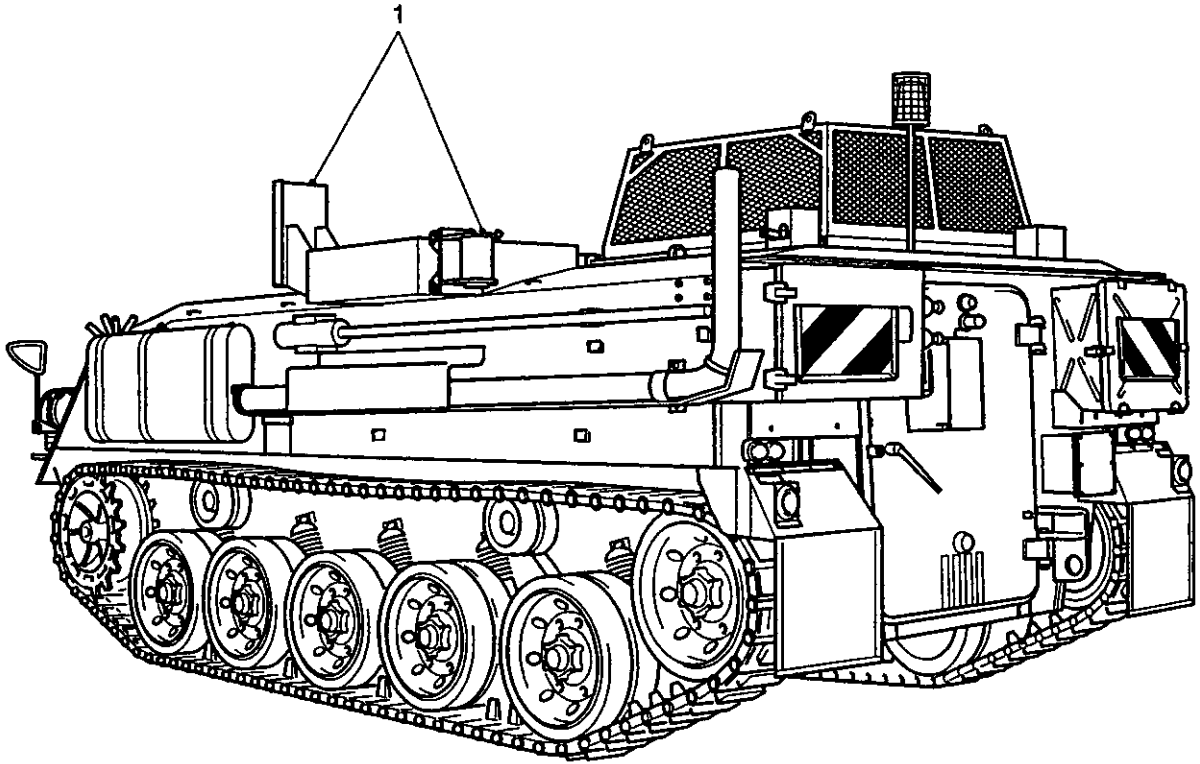

430/30010

1 Hoist unit stowage brackets

Fig 13 Hoist unit stowage brackets

~~RESTRICTED~~

~~RESTRICTED~~

CHAPTER 4
VENTILATION CONTROL SYSTEM

CONTENTS

Para

1	Ventilation system Mk 2
3	Heater
4	Ducting
6	Armoured filter box
9	Filter housing
12	Particulate filter
13	Anti-vapour filter
14	Vehicle air pressure relief valve
18	Valve setting
19	Pressure/suction gauge
	Pressure/suction gauge valve
22	Base
23	Body
24	Plunger
25	Operation
26	Roof vents (WARNING)
27	Ventilation system Mk 2/1
28	Pressure/suction gauge
29	Filter housing
32	Filters
34	Water trap

Fig		Page
1	Ventilation system Mk 2 vehicle.....	2
2	Filters Mk 2 vehicle.....	4
3	Vehicle air pressure relief valve.....	6
4	Pressure/suction gauge valve.....	7
5	Ventilation system Mk 2/1 vehicle.....	9
6	Roof vents.....	10
7	Filter Mk 2/1 vehicle.....	11
8	Water trap.....	12

VENTILATION SYSTEM MK 2 VEHICLE

- 1 The ventilation system (Fig 1) permits air entering the vehicle to be filtered, circulated and heated.
- 2 The air is drawn into the vehicle by a motor driven fan (12) through a filter (9) mounted on the right side at the front of the personnel compartment and circulated through ducting (5) under the roof to diffusers (2) along the sides of and across the front of the personnel compartment, and flexible nozzles (6) in a branch extending forwards through the bulkhead into the driver's and commander's compartment. A relief valve (3) in the roof is set to open when an internal pressure of 76 mm (3.0 in.) standard water gauge is reached.

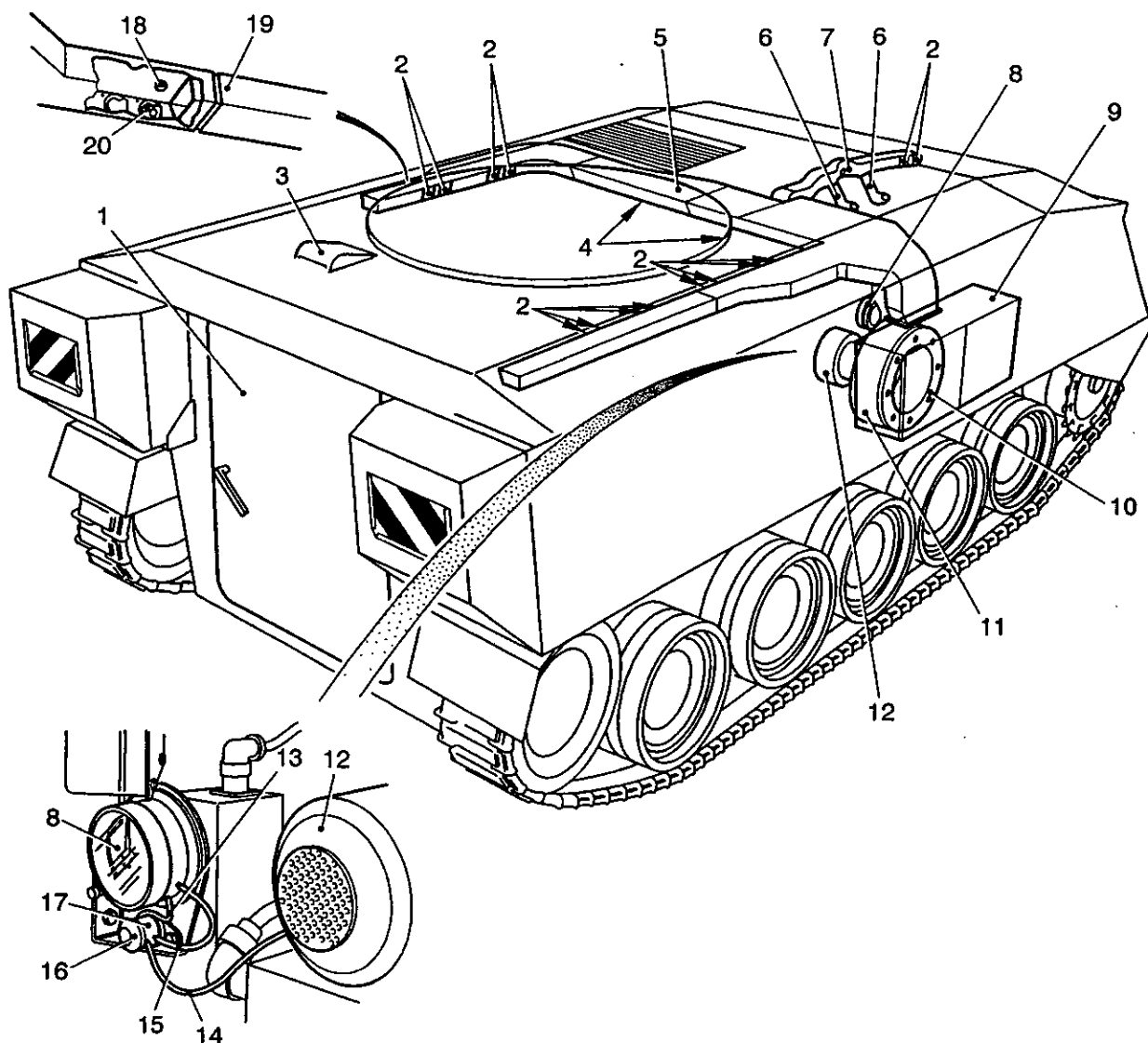

430/30018

- | | | | | | |
|---|---------------------------|----|--|----|--|
| 1 | Rear door | 10 | Flange | 17 | Pressure/depression gauge/valve |
| 2 | Pair of diffusers | 11 | Fan casing | 18 | Nut fixing duct to stud in roof boss |
| 3 | Vehicle relief valve | 12 | Fan motor | 19 | Duct joint self-tapping screw |
| 4 | Single diffusers (two) | 13 | Atmosphere tube | 20 | Rear diffuser of pair affording access to 18 |
| 5 | Ducting | 14 | Valve/filter depression tube | | |
| 6 | Flexible nozzles (two) | 15 | Valve/gauge tube | | |
| 7 | Access plate | 16 | Rubber cupped push button for reading depression | | |
| 8 | Pressure/depression gauge | | | | |
| 9 | Armoured filter box | | | | |

Fig 1 Ventilation system Mk 2 vehicle

Heater

3 A 5kw crew air heater is installed on the RH side of the Command staff compartment, forward of the RH fuel tank. Cold air is drawn into the vehicle from the RH side, heated by burning fuel directed from the vehicle fuel system collector tank. Heat from the heater matrix is blown through flexible ducting to a metal hot air duct for dispersal throughout the vehicle. Exhaust from the matrix is also exhausted on the RH side. The electrical heater starter and blower fan are protected by a 16A fuse.

Ducting

4 The ducting (Fig 1 (5)) is made in sections, which are joined by internal open-ended boxes of the same section as the parts of the ducting to be joined. Each box is inserted in the end of a duct section and spot welded to it, half of the box protruding to form a spigot to support an adjacent duct section. Holes are drilled through the duct and spigot and self-tapping screws (19) are used to secure the joint. Cable trays, which secure communication harnesses, are mounted to the underside of the ducts. They are secured by retaining clamps, socket head button screws, spring and flat washers.

5 Tapped bosses, with studs, welded to the underside of the roof plate support the personnel compartment ducting which is held against the distance pieces by plain and spring lock washers and nuts (18) applied from inside the ducting. Access to these nuts is gained by removing the rearmost diffuser (20) of each pair from the side ducts and the two diffusers (4) in the transverse duct. The ducting in the commanders and drivers compartment is fitted to the compartment left sideplate in a similar manner. There are two fixing points; one is accessible on the removal of the rearmost diffuser of the front pair and the other is made accessible by removing an access plate (7) midway between the flexible pipes, which supply air to the commander.

Armoured filter box

6 The filter housing and filters (Fig 2) are accommodated in an armoured plate box (6) of welded construction. In the bottom plate are cut air inlet slots (26) and welded under these, and to two protection strips (23) are four fabricated wire screens (24) which extend almost to the centre where is welded a clamp pivot bracket (4) which is duplicated on the top plate. A support bracket angle, with a countersunk hole, is welded to each end. On top of the top plate at each end is welded a support channel (9), in the web of which are two countersunk holes, and eight track link stowage brackets (5). To each side plate are welded four hinge plates (13). The box is closed by two armour plate welded fabricated doors each with two hinge lugs (14) each of which fits between a pair of hinge plates and is secured by a hinge bolt (12).

7 Each door has a grab handle (20) welded to its lower edge. The front door has inside its opening edge a protruding strip (19) on which the rear door bears. Both doors have welded on their top and bottom edges a clamp bracket (17) slightly set back from the opening edges. L section blanking plate stowage lugs (21) are welded on the inner faces of each door, two being disposed horizontally near the bottom edge and one vertically near the hinged edge just below the centre of the door. Below the top of each door are two studs on each of which are fitted a retaining clip (16), double coil lock washer, plain washer and an aero tight nut (15).

8 In the clamp pivot, brackets (4) welded to the top and bottom plates are inserted pivot pins (3) retained by circlips (2). The pivot pins are drilled and tapped to receive clamp screws (7) with mills pins passed through their ends to prevent complete withdrawal. Through the shouldered heads of the clamp, screws are fitted 'tommy' bars (8). The doors are clamped shut by swinging the clamp screws into the gap between adjacent door clamp brackets and tightening the clamp screws by means of the tommy bars provided.

Filter housing

9 The filter housing (38) is a welded and brazed fabricated open fronted rectangular sheet metal box with stepped sides and ends. A circular hole cut in the back plate affords communication with the interior of the vehicle via a flexible connection (37). The housing is fitted at each end with four mounting plates (31) incorporating threaded studs. On the top and bottom of the housing are welded two slotted brackets (25) for the reception of two cross bars (10) forming part of two cruciform filter holder clamps (22). On the front edge is welded a holder for a spanner (11) used for tightening the clamps. Sealing material is stuck to the inner part of the frames against which the filters are clamped. On the studs of each mounting plate (31) is fitted a flange of a Metalastik equi-frequency mounting (29), the centre flexibly mounted bolt of which engages with one of the four brackets (28) which carry the filter housing. The controlled vibration thus provided increases filter life by shaking from the particulate filter outer surfaces some of the foreign matter trapped by the filter.

10 The flexible connection (37) between the filter housing and the vehicle is a moulded rubber hollow cylinder flanged at each end with an omega shaped (Ω) central section. One flange is introduced into the filter housing against the inner face of which it is clamped by a steel ring through which are drilled equally spaced holes for the reception bolts, spring washers and nuts. A similar clamping ring (36) secures the other connection flange against the vehicle small side plate (34).

11 Inserted first in the housing are the anti-vapour (33) substitute filters. These are followed by the particulate filters (32). The cross bar (10) of each clamping device is entered in the slots of the brackets (25) provided and given a clockwise part-turn. The feet of each cruciform member are placed on the filter frame (27) and the central screw tightened.

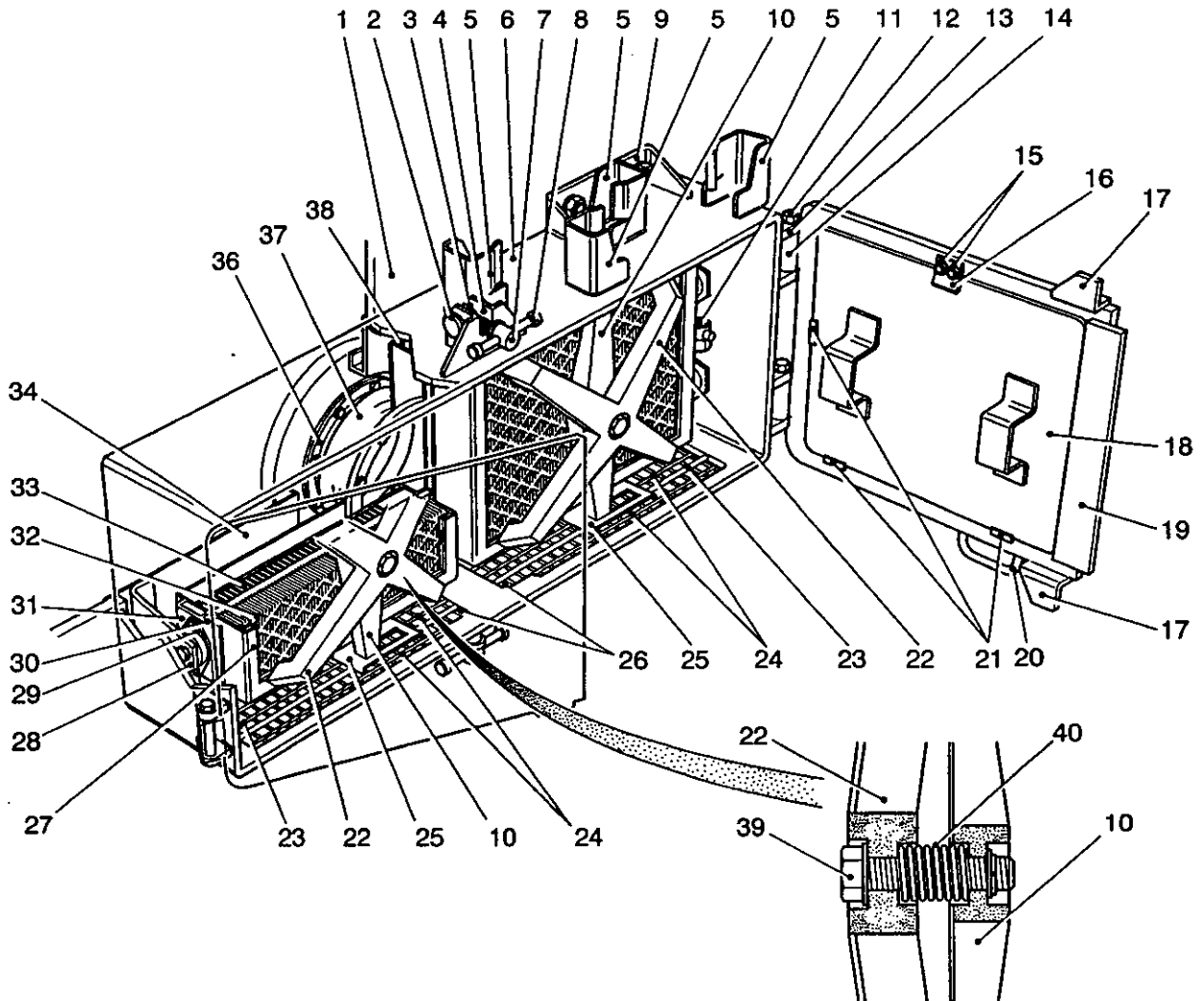

432/352

1	Hull right upper side plate	15	Aero tight nut	28	Filter housing support bracket
2	Circlip	16	Retaining clip	29	Metalastik mounting flange
3	Pivot pin	17	Clamp bracket	30	Seal
4	Clamp pivot bracket	18	Blanking off plate stowed	31	Mounting plate
5	Track link stowage bracket	19	Strip	32	Particulate filter
6	Armoured filter box	20	Grab handle	33	Anti-vapour filter
7	Clamp screw	21	Blanking off plate stowage lugs	34	Small side plate
8	Tommy bar	22	Cruciform clamp	35	Side plate steel ring
9	Support channel	23	Protection strip	36	Housing steel ring
10	Cross bar	24	Fabricated wire screen	37	Flexible connection
11	Spanner	25	Slotted bracket	38	Filter housing
12	Hinge bolt	26	Air inlet slots	39	Clamp screw
13	Hinge plate	27	Filter frame	40	Spring

Fig 2 Filters, Mk 2 vehicle

Particulate filter

12 This filter has a Phenolic impregnated rag based paper element supported between two flattened expanded metal sheets, white stove enamelled before assembly, and held in a mild steel frame. The element is folded backwards and forwards to produce 80 fins. The fins are equally spaced and are kept so by two spacing strips or paper or felt stuck to them by adhesive. The gross filter paper area is 8.8 sq m (21 sq ft) and the filter has a rating w and produces a pressure drop of 7.6 mm (0.3 in.) standard water gauge. Two shallow top hat section location brackets are spot welded or silver soldered to the frame end faces. The ends of the fins are sealed to the frame with PVC and the end fins using adhesive. The frame joints on both filters occupy the outermost positions in the filter housings.

Anti-vapour filter

13 The filter frame is similar to that employed in the particulate filter. The element, however, consists of activated carbon suspended in an angled honeycomb frame in which it is sandwiched between layers each side of woven glass mesh which retains it in the honeycomb. Two hinged handles are provided. The frame joints on both sealing faces are filled with an exoxide resin mix and finished flush. The element is rated at 76.25 cu m min (250 cu ft min) at which it imposes a permissible pressure drop of up to 111.8 mm (4.4 in.) standard water gauge. Two of these filters occupy the innermost positions in the filter housing.

Vehicle air pressure relief valve

14 This valve (Fig 3) is fitted in the left roof plate near the rear of the vehicle and is set to open when the internal air pressure reaches 76 mm (3 in.) standard water gauge. Overlapping the aperture in the roof under which it is fitted is a flap seating and mounting (9) for a flap valve (12). Six fixing holes are provided, one each side and two each in the front and rear sides. On the centre line at the rear are two countersunk clearance holes for 2BA screws and at the front two holes tapped 4BA. A gasket is interposed between the frame and the roof and another between the frame and the flap. The two 4BA tapped holes on the centre line of the front side of the flap mounting accept countersunk screws which retain, under the mounting, a mild steel plate with corresponding countersunk holes, a thin 0.203 mm (0.008 in.) single spring leaf (11) and a nylon rubbing strip (10). The two latter are set so that the rubber strip bears on the underside of the flap and tends to open it in opposition to the load imposed by the rubber springs (1).

15 Beneath the rear centre of the frame is fitted a pillar (3) secured by the two 2BA screws (4) mentioned above which are passed downwards through the frame and screwed into two tapped holes in the pillar to clamp it to the underside of the frame. The rear-tapped holes extend right through the pillar. The pillar is drilled and reamed 13 mm (0.5 in.) transversally and a slot communicating with the reamed hole permits a clamping action to be exerted when a slotted hexagon headed 2BA screw is inserted in the bottom of the through hole in the pillar which is relieved below the slot to clear the screw.

16 The reamed hole accommodates a bush (13) made from mild steel hexagon rod 13 mm (0.5 in.) across the flats and cadmium plated after manufacture. The bush is 39 mm (1.5 in.) long and is turned down to 13 mm (0.5 in.) diameter except for 7.9 mm (5/16 in.) at one end, which is left hexagonal (13) for the application of a spanner. It is drilled and tapped 5/16in. BSF along its axis and recessed each end for 3.1 mm (0.12 in.) by an 8.6 mm (11/32 in.) drill. A 1.613 mm (0.0635 in.) hole is drilled 7.5 mm (0.25 in.) from the plain end to communicate with the bore.

17 Into each end of the bush is screwed one end of the spindle of a Metalastik rubber mounting which in this application is used as a spring (1) to maintain a hinged flap valve (12) on its seating until the air pressure in the vehicle rises enough to lift the flap. The other end of each rubber-mounting spindle carries a hinge bracket (8) a right angle extension of which is secured to the flap by two 6.3 mm (0.25 in.) 4BA cheese-headed screws. Between each rubber mounting and its hinge bracket is interposed a 7.9 mm (5/16 in.) shake proof lock washer (5) with external teeth. On the end of each spindle is a 7.9 mm (5/16 in.) plain washer (6) maintained in contact with the outer face of each bracket by a 7.9 mm (5/16 in.) single coil lock washer (7) and a 7.9 mm (5/16 in.) BSF hexagon nut. The left rubber-mounting spindle is locked to the steel bush held by the pillar clamp by a pin, which passes through spindle and steel bush.

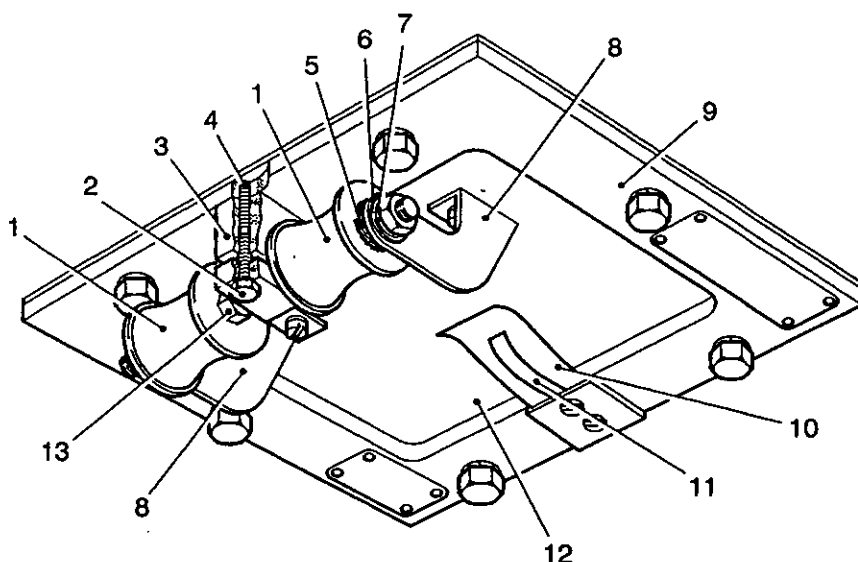

432/353

1	Metalastik rubber spring	8	Hinge bracket
2	Clamping screw	9	Flap seating and mounting
3	Slotted pillar	10	Nylon rubbing strip
4	Pillar mounting screw	11	Spring
5	Shake proof lock washer	12	Flap valve
6	Plain washer	13	Bush hexagon
7	Single coil spring washer		

Fig 3 Vehicle air pressure relief valve

Valve setting

18 The rubber torsion springs must be adjusted so that when installed in a vehicle the valve begins to open when the vehicle internal air pressure reaches 76.2 mm (3 in.) standard water gauge. Prior to final adjustment when installed the angle of twist is set at 25 degrees by turning the steel bush by a spanner applied to its hexagonal head through 25 degrees and locking it in that position by a pillar clamp screw. The maximum allowable gap between the flap and its seat gasket is 0.25 mm (0.010 in.)

Pressure/suction gauge

19 The diaphragm type gauge (Fig 1(8)) is mounted at the front of the personnel compartment on the right. It is calibrated in inches standard water gauge. Zero is marked at the top centre of the dial and on either side of it is engraved figures 1 to 9. The right set of figures indicates internal vehicle air pressure when the pointer moves clockwise. The left set of figures indicates the depression between the fan and filters when the hand moves anti-clockwise. A plug in the bottom centre of the dial reveals, on removal, a zeroing screw by means of which the pointer may be set to zero, should it not already be so, when the fan is not working and the interior of the vehicle is at atmospheric pressure by reason of an opened door or hatch.

20 Two adaptors, to which pipes are fitted, are provided on the right of the gauge. The lower adaptor communicates with the atmosphere via piping (13) and a vent pipe, which extends upwards through the vehicle roof. The upper pipe communicates by piping (15) with an adaptor marked G+ on a pressure/suction gauge valve fitted below the gauge. In this pipe is felt depression and pressure, according to the setting of the valve.

21 Gauge readings should not exceed 76.2 mm (3.0 in.) SWG pressure or 127 mm (5.0 in.) SWG depression. If they do the indications are, in the first case, that the fan is overworking or the vehicle pressure relief valve is not operating properly, or both; in the second case, that the filters are clogged and need cleaning or replacing, or that the blanking plates have not been removed.

Pressure/suction gauge valve

Base

22 The valve (Fig 1(17) and Fig 4)) consists of a lozenge shaped nickel-plated brass base (Fig 4(2)) with two countersunk fixing holes at its ends. Three similar holes are equally spaced about the centre by means of which the valve body (3) is secured to the base, the thickness of which is reduced in the centre and provides a clearance between the base and the surface against which it is mounted for a central 2.8 mm (7/64 in.) hole.

Body

23 The valve body (3) is a two-diameter hollow cylinder externally flanged at each end. One flange has three blind tapped holes by which it is mounted on its base. A single radial hole (5) is drilled through the edge of the flange and communicates with the inside of the cylinder. The outer flange provides a mounting for a rubber cap (10) which covers one end of a spring-loaded plunger (9), which can be pushed inwards by finger or thumb pressure against the rubber cap. Two short pipes communicating with the inside of the cylinder are inserted in radial holes and secured by brazing. Against one of these are inscribed the symbols G+ (1) and against the other (6) the letter F, signifying gauge and filter connections respectively.

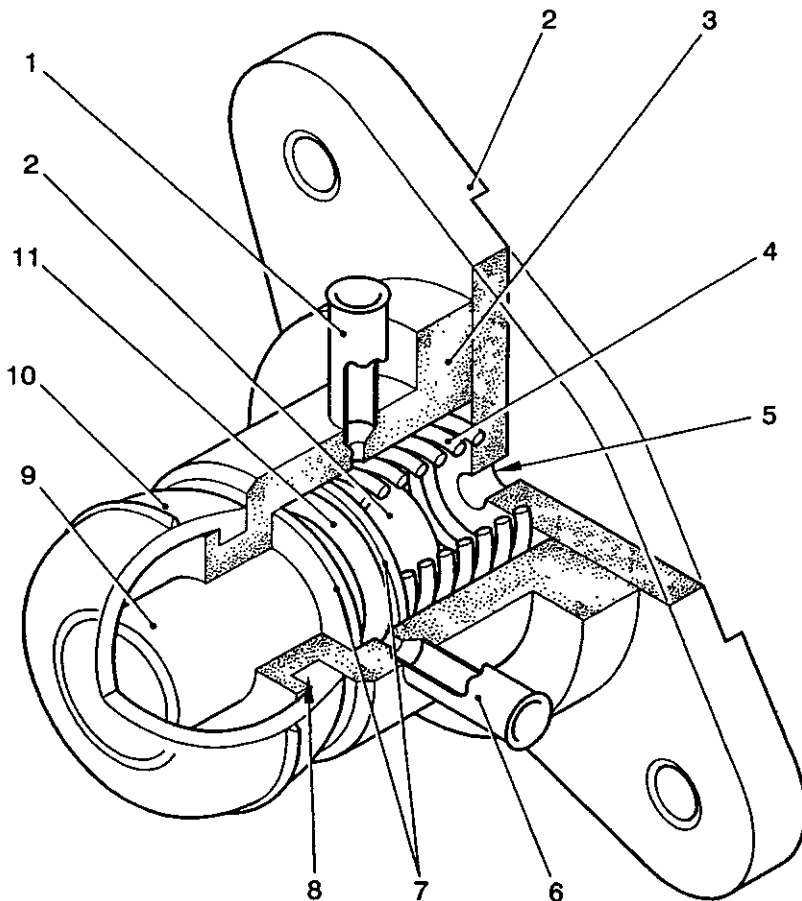

432/354

- | | | | |
|---|--|----|---------------|
| 1 | Branch pipe to pressure/suction gauge | 7 | Piston |
| 2 | Relieved brass base | 8 | Recess |
| 3 | Cylinder body | 9 | Plunger |
| 4 | Spring | 10 | Rubber cap |
| 5 | Inlet port for vehicle internal pressure | 11 | O-ring |
| 6 | Branch pipe to filter/fan junction | 12 | Spring spigot |

Fig 4 Pressure/suction gauge valve

Plunger

24 The plunger is a two-diameter solid cylinder of red anodised aluminium with a central recessed collar in which is fitted an O-ring (11). The smaller diameter of the plunger forms a spigot (12) for a coil spring and the larger is a sliding fit in the valve body. The valve parts are assembled in the following order, rubber cap, O-ring in plunger recessed collar, plunger into valve cylinder, larger diameter first, coil spring, base.

Operation

25 The construction of the valve is shown in Fig 4 and the valve and gauge connections in an inset in Fig 1. The valve is normally closed with regard to the pipe marked F and normally open with regard to the pipe marked G+. Internal vehicle pressure enters the valve body through the holes in the base and body flange and, in the un-operated position, passes out through pipe G+ (Fig4 (1)). An external connection (Fig 1(15)) connects pipe G+ to the upper of two adaptors in the pressure/suction gauge, which will thus show, normally, the internal vehicle air pressure. Valve pipe F (Fig 4(6)) is externally connected (Fig 1(14)) to a point between the fan and filter where a depression exists whenever the fan is working. When the plunger is operated, direct communication is provided within the valve between pipes F and G+, and vehicle internal pressure cut off from both pipes. Depression is felt in the pipe (Fig 1(15)) connecting the valve to the gauge, which then registers the degree of vacuum existing between the fan and filter. The lower gauge adaptor (13) is connected to a vent pipe, which passes out through the vehicle roof to the atmosphere.

Roof vents

26 Five roof vents (Fig 6) are provided and the form of drilled cylindrical bosses welded to machined hole in the hull roof. Each vent is open to atmosphere above the roof, the vents and has a cylindrical cowl retained by a centre bolt. The inner end of each vent has an adaptor to provide a connection for battery flame traps (Chap 5 refers), with exception of the two vents (Fig 6(3)) that are provided to meet the needs of additional batteries that are required for a specialized role the vehicle can undertake. Until required, two screwed blanking plugs seal these vents.

VENTILATION SYSTEM MK 2/1 VEHICLE

27 The ventilation system is similar in layout an operation to that described in preceding paragraphs for the Mk 2 vehicle. The differences are described in the following paragraphs and illustrated in Figs 7 and 8.

Pressure/suction gauge

28 A small-bore pipe from the fan-mounting pedestal connects with a test button (Fig 5(14)) and pressure/suction gauge (7), (which are described in preceding paragraphs for the Mk 2 vehicle). Two brackets position the water trap (Fig 8) to the rear of the ventilation fan control unit. This trap unit is so connected in the gauge vent tube to remove any moisture and dust that may be present in air drawn in from atmosphere that could cause a malfunction of the pressure/suction gauge.

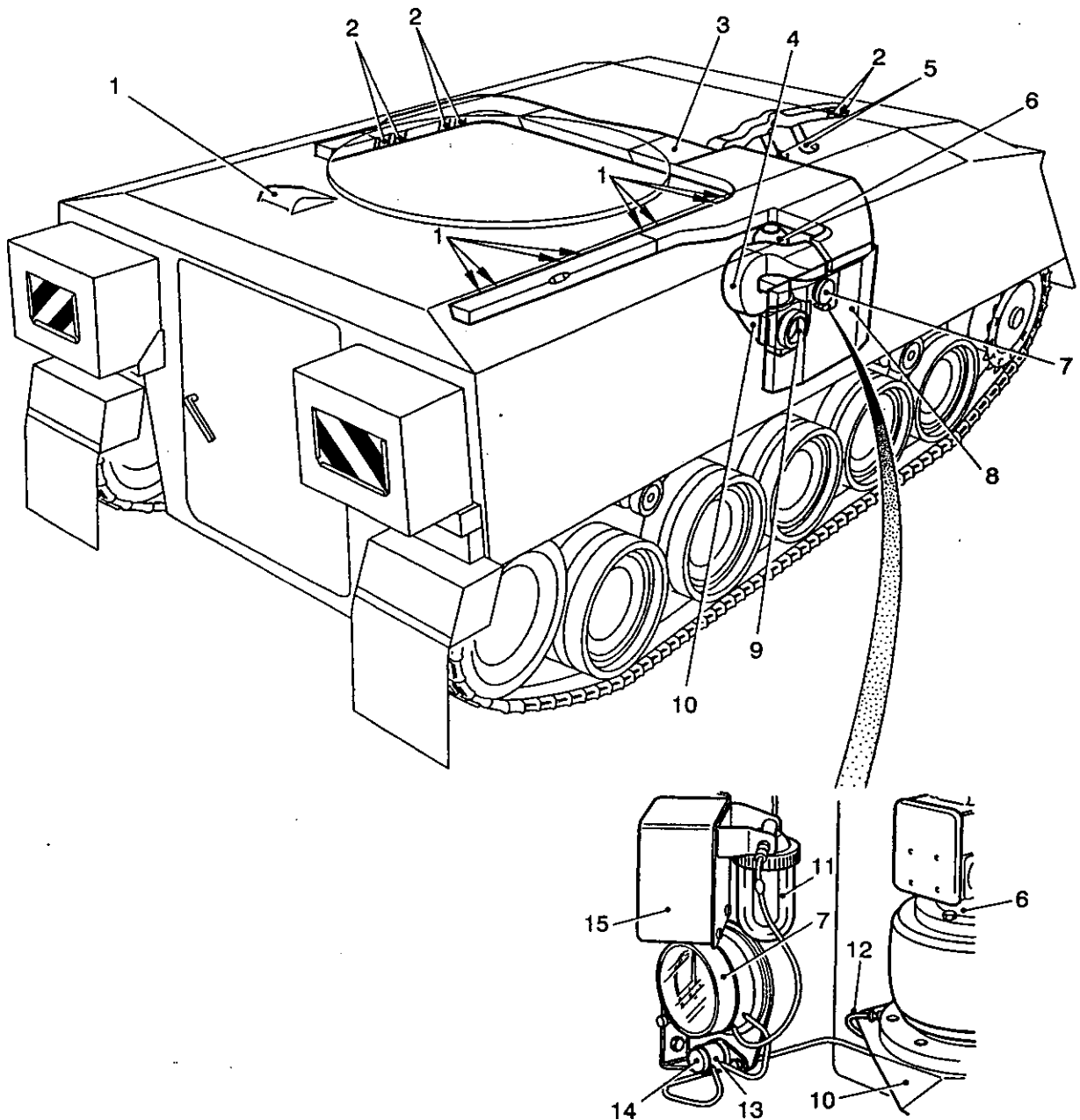

430/30019

- | | | | |
|---|---------------------------|----|------------------------------------|
| 1 | Vehicle relief valve | 9 | Flexible connections |
| 2 | Pair of diffusers | 10 | Fan mounting pedestal |
| 3 | Ducting | 11 | Water trap |
| 4 | Connecting duct | 12 | Valve/filter depression tube |
| 5 | Flexible nozzles | 13 | Pressure/depression gauge valve |
| 6 | Fan motor | 14 | Push button for reading depression |
| 7 | Pressure/depression gauge | 15 | Fan speed control |
| 8 | Filter box cover | | |

Fig 5 Ventilation system, Mk 2/1 vehicle

Filter housing

29 The filter housing (Fig 7) is similar in construction to the Mk 2 vehicle, the major difference being that the housing has been repositioned inboard, thus dispensing with the armoured box, the filter holders are turned through 90 degrees and a different type of Metalastik mounting has been employed. The filter housing (5) is mounted in a box (4) that is connected by a duct (2) to the air inlet in the roof; an armoured cowl (3) welded to the roof plate protects the air inlet. The box and duct are an integral part of the welded hull structure.

30 The opening of the box in the vehicle right side plate is sealed by a hinged armour cover (21) which has a landing strip welded around its inner face, angle strips welded to the inner sides of the landing strip provide a mount for a sponge rubber Linatex seal (19) which is affixed with adhesive and retained in position by a steel retaining strip. The cover is clamped by six eye bolts (1) which have hinge points welded to the hull, the eye bolts engage in hasp brackets (20) welded to the cover. A stowage bracket welded to the inner face of the cover accommodates the spanner (22) required for the filter clamp screws. The filter cover clamp bolts spanner is stowed in the crew-mounting step adjacent to the cover when not required.

31 Two tubular flexible connections (7) and (9) of corrugated section are positioned between the filter housing and box, and the filter housing and fan mounting pedestal (8) respectively, the pedestal being located in the personnel compartment. Both connections are clamped in a similar mode to that used on the Mk 2 vehicle (see Para 10).

Filters

32 The filters, although similar in construction and dimension to the filters used by the Mk 2 vehicle, have been designated Particulate Filter No. 2, Mk 2 (13) and Anti-vapour Filter No. 2, Mk 1 (11).

33 The particulate filter has a similar rating to the description given in Para 11, however, the Anti-vapour Filter is rated at 76.25 cu m min (250 cu ft min) at which a pressure drop of less than 171.5 mm (6.75 in.) standard water gauge is permissible. At 45.75 cu m (150 cu ft min) a pressure drop of less than 76 mm (3.0 in.) SWG is allowed.

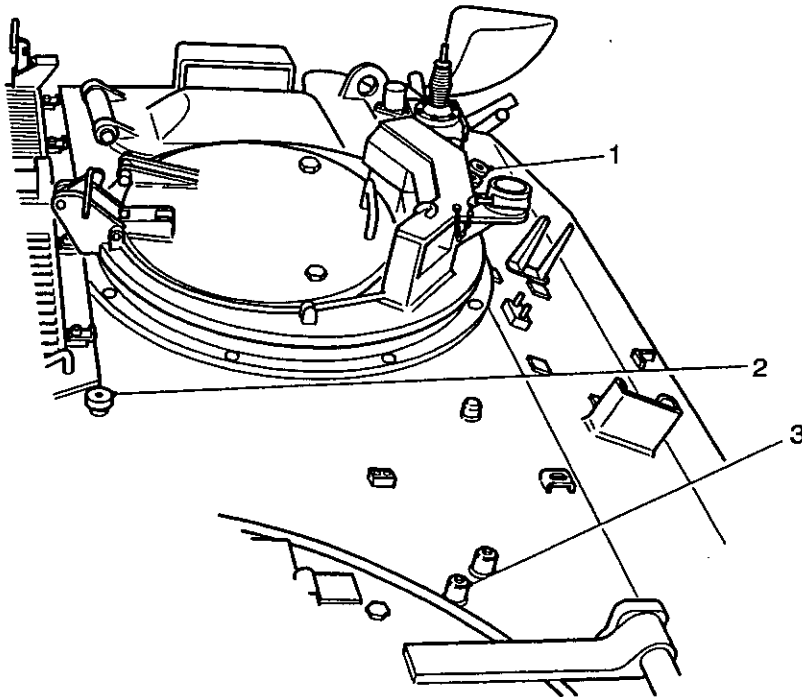

430/30011

- | | | | | | |
|---|------------------------------------|---|--------------------------|---|---------------------------------|
| 1 | Automotive and Radio battery vents | 2 | Ventilation battery vent | 3 | Specialised roles battery vents |
|---|------------------------------------|---|--------------------------|---|---------------------------------|

Fig 6 Roof vents

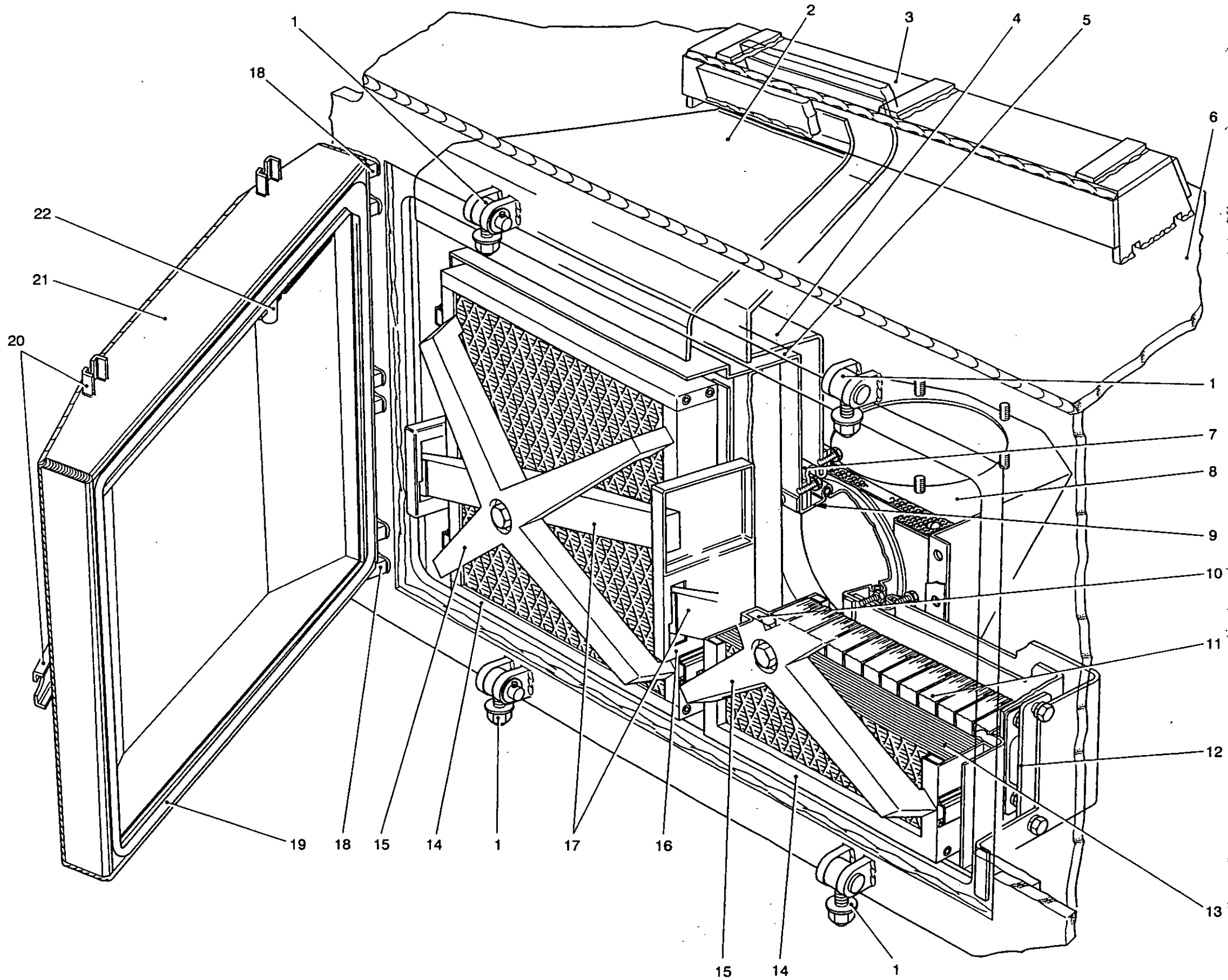

- 1 Eyebolts
- 2 Air inlet duct
- 3 Air inlet
- 4 Filter box
- 5 Filter housing
- 6 Roof plate
- 7 Flexible connection, filter housing to filter box
- 8 Fan mounting pedestal
- 9 Flexible connection, filter housing to fan pedestal
- 10 Seal
- 11 Anti-vapour filter
- 12 Metalastik mounting
- 13 Particulate filter
- 14 Filter frame
- 15 Cruciform clamp
- 16 Slotted bracket
- 17 Cross bar
- 18 Cover hinge brackets
- 19 Seal
- 20 Hasp brackets
- 21 Cover
- 22 Spanner

Fig 7 Filters, Mk 2/1 vehicle

Water trap

34 The trap body (Fig 8(3)) is suspended from two brackets (2) by the inlet and outlet tube adaptors (1). Air enters the inlet port at atmospheric pressure and passes into a annular groove that directs the flow over a louvred cone (12) that imparts a whirling motion to the air stream, so that any drops of liquid are thrown against the inside of a clear plastic bowl (7) that is sealed by an O-ring (5) and retained by an embossed clamping ring (6). The airflow passes through, depositing any dust or moisture present onto a washable porous plastic sleeve (8) and a 200 mesh reinforced Monel wire screen (9), and then through the outlet port to the pressure/suction gauge. The plastic sleeve is a slide fit over the wire screen, which is retained by a self-locking nut (10) that screws onto a stud (11) cast into the body.

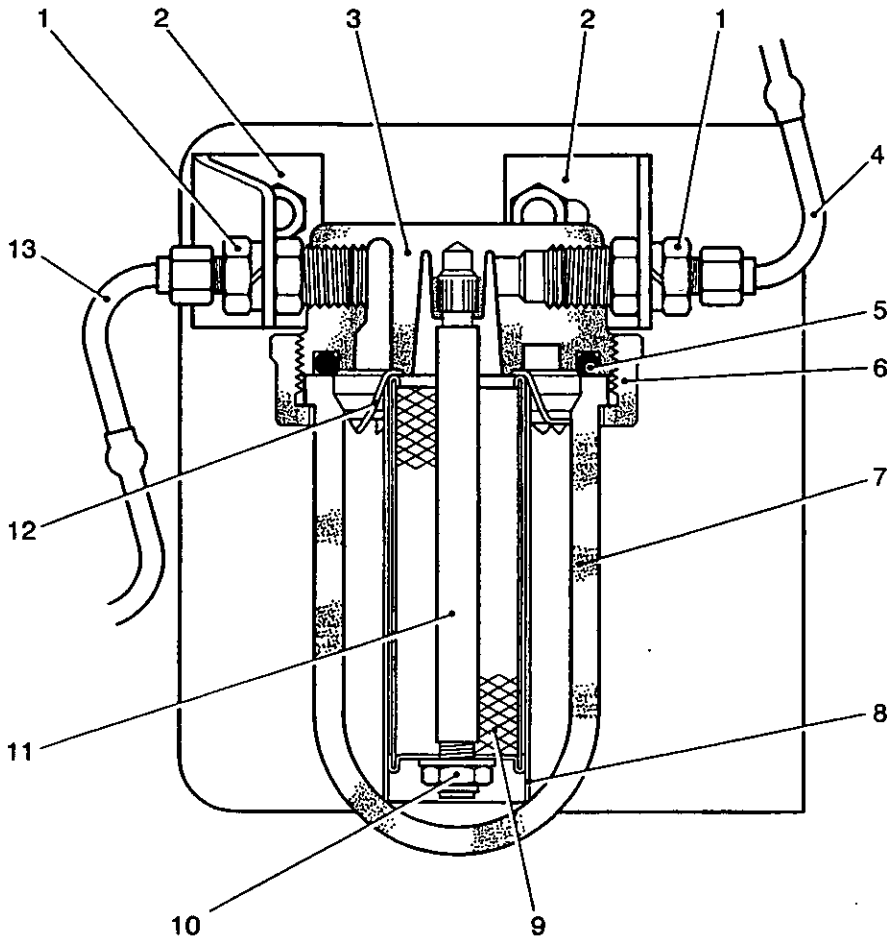

432/357

- | | | | |
|---|---------------|----|----------------|
| 1 | Adaptors | 8 | Plastic sleeve |
| 2 | Brackets | 9 | Wire screen |
| 3 | Trap body | 10 | Retaining nut |
| 4 | Outlet | 11 | Stud |
| 5 | O-ring | 12 | Louvred cone |
| 6 | Clamping ring | 13 | Inlet |
| 7 | Plastic bowl | | |

Fig 8 Water trap

CHAPTER 5
ELECTRICAL EQUIPMENT
CONTENTS

Para	
1	General
	Generating system Mk 2 and 2/1 vehicles
8	General
17	Batteries
25	Flame trap
31	Analogue connector No. 1, Mk 1
36	Alternator No. 1, Mk 1
39	Rotor
41	Drive gear
42	Stator and body
46	Field
47	Drive endplate
51	Rear end shield
56	Cooling system
58	Operation
61	Control panel alternator No.1, MK 1
64	Panel 1
65	Panel 2
66	Panel 3
67	Panel 4
68	Silicon controlled rectifiers
	Operation
79	Rectifier unit No. 1, Mk 1
81	Panel
84	Upper compartment
88	Lower compartment
95	Operation of generating system
99	Radio battery charging
102	Distribution link box No. 1, Mk 1
106	Load sharing transformer
109	Control circuit panel
112	Solenoid switch
114	Warning light
116	Distribution panel No. 6, Mk 1
119	Battery switch
127	Solenoid switch
134	Relay assembly
141	Circuit breakers
145	Battery selector switch
149	Radio distribution box, No. 1, Mk 3
154	Battery switch
155	Relay
156	Terminal cover assembly
163	Operation
164	Driver's control panel assembly
165	Turn light switch board No. 1, Mk 2
166	Turn light switch No. 2, Mk 2
171	Turn light flasher unit (Bosch)
176	Operation
180	Turn light warning light
181	Main beam warning light
182	Engine switch board No. 3, Mk 1

(continued)

CONTENTS (continued)

Para	
183	Generator warning light
185	Oil pressure warning light
188	Engine switch
191	Starter switch
195	Modifications
196	External lighting switch board
197	Twin dipswitch No. 1, Mk 2
199	Switch mechanism
206	Operation
209	Instrument panel No. 3, Mk 1
211	Panel assembly
219	Speedometer No. 4, Mk 1
220	Tachometer No. 1, Mk 1
221	Coolant thermometer
225	Gearbox oil thermometer
226	Fuel gauge
227	Tank unit
229	Indicator
230	Operation
231	Ammeter No. 5, Mk 1
233	Dimmer resistance
234	Panel lights
	Horn No 1, Mk 1
236	Horn push button
237	Traffic horn
	External lighting
242	Headlight No. 2, Mk 1
249	IR driving light No. 1, Mk 1
252	Side light No. 3, Mk 3
257	Turn light No3, Mk1
258	Tail stop light No. 3, Mk 1
260	Registration plate light No. 1, Mk 2
263	Convoy light No. 2, Mk 5
265	Gear range selector switch
268	Trailer relay assembly
269	Operation of external lighting
274	Fascine lighting
276	Spotlight No.1, Mk 1
279	Interior lighting
283	Roof light No. 3, Mk 1
286	Blackout switch - Craig and Derricott type VSP1
287	Smoke discharger junction box No. 3, Mk 1
288	Radio Frequency (RF) filter unit No. 3, Mk 1
295	Driver's periscope wiper motor
305	Motor driving No. 8, Mk 1 (FAN)
319	Controller fan No. 1, Mk 2
326	Bowman radio system
331	Driver's station
332	Vehicle commander's station
334	Command staff compartment
338	Fire alarm system
342	Firewire control box No. 1, Mk 1
343	Warning light unit No. 3, Mk 1
356	Warning light No. 3, Mk 3
357	Horn No. 2, Mk 1
359	Sensing element (firewire) loop

(continued)

CONTENTS (continued)

Para		
367	Operation	
372	Firewire hot	
379	Firewire cold	
380	Testing	
383	Pump, fuel pressurizing, No. 2, Mk 1	
392	Fuel cut-off solenoid CAV type 236A-46	
Table		Page
1	External lighting switching arrangement.....	64
Fig		Page
1	Electrical installation diagram, Mk 2/1.....	7
2	Block wiring diagram for vehicles equipped with distribution panel No. 6 MK 1	8
3A	Schematic wiring diagram, Mk 2 and 2/1.....	10
3B	Schematic wiring diagram, Mk 2 and 2/1 (continued).....	11
4	Engine components wiring diagram less alternators and firewire	12
5	Ventilation batteries and container.....	14
6	Battery vent - flame trap	16
7	Alternator section No. 1, Mk 1	17
8	Alternator - body assembly	18
9	Alternator resilient mounted seals.....	19
10	Alternator oil inlet and outlet ports.....	20
11	Alternator drive gear case	21
12	Alternator diagram of operation.....	22
13	Control panel No. 1, Mk 1, cover removed.....	23
14	Control panel field excitation circuit	25
15A	Charging circuit wiring diagram.....	26
15B	Charging circuit wiring diagram (continued)	27
16	Rectifier unit No. 1, Mk 1	29
17	Rectifier unit - lower cover removed	30
18	Rectifier unit - top panel.....	31
19	Rectifier unit - choke	32
20	Rectifier unit - heat sink assembly	33
21	Distribution link box.....	35
22	Load sharing transformers	36
23	Control circuit panel.....	37
24	Solenoid switch.....	38
25	Distribution panel No. 6, Mk 1	39
26	Distribution panel No. 6, Mk 1 - cover open.....	40
27	Battery switch.....	41
28	Solenoid switch.....	42
29	Solenoid switch - base assembly	43
30	Solenoid switch - cover removed	44
31	Relay assembly	45
32	Radio distribution box No. 1, Mk 3	47
33	Driver's switchboard	48
34	Turn light switch board	49
35	Engine and external lighting switchboard	52
36	Headlight or infra red light dipswitch	53
37	Instrument panel	55
38	Fuel gauge tank unit.....	56
39	Headlight.....	59

(continued)

CONTENTS (continued)

Fig		Page
40	IR driving light	60
41	Sidelight	60
42	Registration plate light	61
43	Convoy light	62
44	Gear range selector switch	63
45	Diagram of auxiliary junction box and associated circuits.....	66
46	Blackout switch	67
47	Periscope wiper motor.....	69
48	Fan driving motor.....	70
49	Driving motor - exploded view.....	71
50	Schematic diagram of Command equipment.....	73
51	Warning light unit.....	75
52	Firewire element and termination coupling.....	77
53	Firewire coupling.....	78
54	Fire warning wiring diagram	80
55	Pump, fuel pressurizing No. 2, Mk 1	81
56	Fuel cut-off solenoid	82

GENERAL

- 1 The electrical installation diagram for the No. 2/1 vehicles is shown at Fig 1, the block wiring diagram of Mk. 2 and 2/1 vehicles at Fig 2A and 2B, the schematic wiring diagram of Mk 2 and 2/1 vehicles at Fig 3A and 3B, the engine components wiring diagram at Fig 4 and the components associated with the No 6 Mk1 distribution box at Fig 5.
- 2 Electrical equipment fitted to the power pack consists of two alternators (Fig 1(41)), a starter motor (39), oil pressure switch (40), coolant thermometer (37), gearbox oil thermometer (34), a fuel pump cut-off solenoid (35) and FIREWIRE associated with a fire alarm system. These circuits (Fig 3A and 3B) are controlled by the driver's engine switch.
- 3 The alternators are of the wide speed range type and for normal use their three phase ac outputs are connected in parallel at a distribution link box (Fig 1(62)), the combined output from this box being connected to a rectifier unit (38) and the dc output is then available to supply the electrical load and to charge the three sets of batteries.
- 4 A No. 3, Mk 1 starter motor is fitted to the engine and incorporates a built in thermal trip switch to safeguard the motor against overheating and to prevent discharging the batteries in an attempt to start a faulty engine. This switch is connected in the solenoid switch circuit and in the event of the motor overheating, the switch operates to open circuit the solenoid switch coil and thus to stop the motor. The switch re-closes automatically when the starter cools down. For a description of the motor, EMER Power P 322/11 refers.
- 5 The Mk 2 and Mk 2/1 vehicles are fitted with Distribution Panel No. 6 Mk 1, which now combines the functions of the distribution panel No 5 Mk 1 and the accessories control box used on earlier vehicles. The battery master switch on this panel controls both the automotive and the ventilation batteries, the two sets of batteries being connected to separate pairs of contacts in the switch (Fig 5). The automotive batteries are connected direct to the vehicle positive line via the battery switch but the ventilation batteries are connected to the positive line via the battery switch and RLB which is energized when RLA 1 closes. This relay closes when the alternator voltage reaches approximately 16V and the ventilation batteries are then charged simultaneously with the automotive batteries.
- 6 Providing the battery switch is on, the ventilation batteries will supply power to the ventilation system and external penthouse lights (if fitted).
- 7 Circuit breakers for the electrical system are housed , under a cover, on the distribution panel.

KEY TO FIG 1

1	Instrument panel	34	Gearbox oil thermometer bulb
2	Sight wiper switch	35	Fuel pump cut-off solenoid
3	Fire warning light	36	Power pack junction panel
4	Interior light	37	Coolant thermometer bulb
5	FIREWIRE control box	38	Oil tank and rectifier unit
6	Automotive batteries with arctic muff	39	Starter motor
7	Ammeter shunt	40	Oil pressure switch
8	Distribution panel	41	Alternators
9	Suppressor unit for sight wiper motor	42	Battery container
10	Sight wiper motor	43	Ventilation batteries
11	Battery vents	44	Insulated terminal for stowage of ventilation battery positive connector
12	Smoke grenade discharger switchbox	45	Ventilation battery negative (earth) connection
13	Auxiliary junction box	46	Smoke grenade discharger junction box
14	Fan controller	47	Sidelight
15	Radio Distribution box	48	Headlight
16	Fire warning light with flasher unit	49	Front turn-light
17	Fan motor	50	IR driving light
18	Spotlight	51	Smoke grenade discharger
19	Ventilation battery vent	52	Radio batteries
20	Batten box, internal - radio	53	Gear control lever switch
21	Batten box, external - radio	54	Dipswitch
22	Fuel gauge transmitter	55	Steering lever switches
23	Tail - stoplight	56	No. 1 connection junction
24	Rear turnlight	57	Fire warning horn
25	Door contacts assembly	58	Turn-light switchboard
26	Registration plate light	59	Engine switchboard
27	Blackout switch	60	External lighting switchboard
28	Stowage bracket for radio harness	61	Horn push
29	Convoy light	62	Distribution Link box
30	Trailer relay	63	Rear alternator control panel
31	No. 2 connection junction	64	Front alternator control panel
32	Fuel pump	65	Horn
33	Engine junction box		

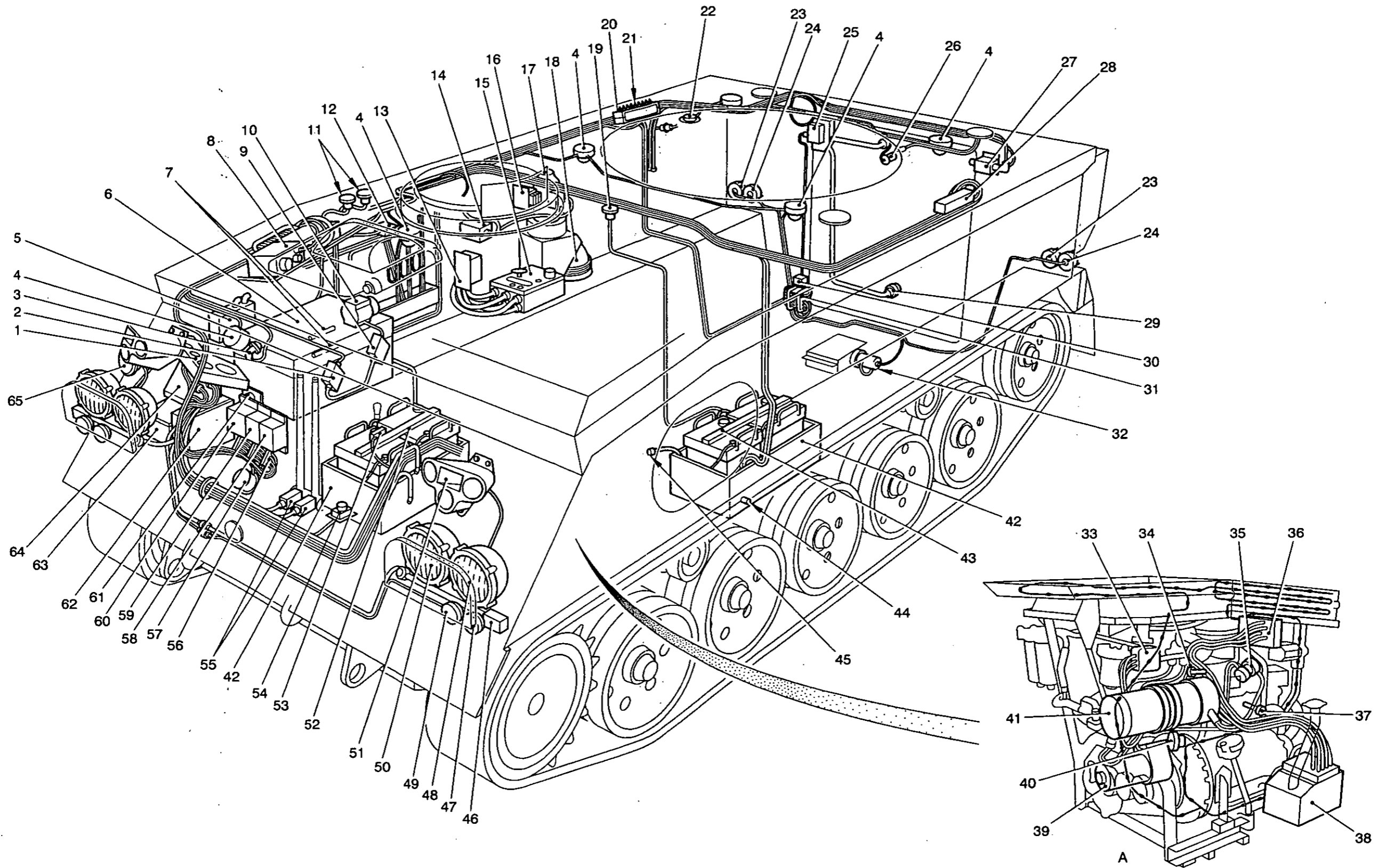

Fig 1 Electrical installation diagram Mk 2/1 vehicles

430/30003

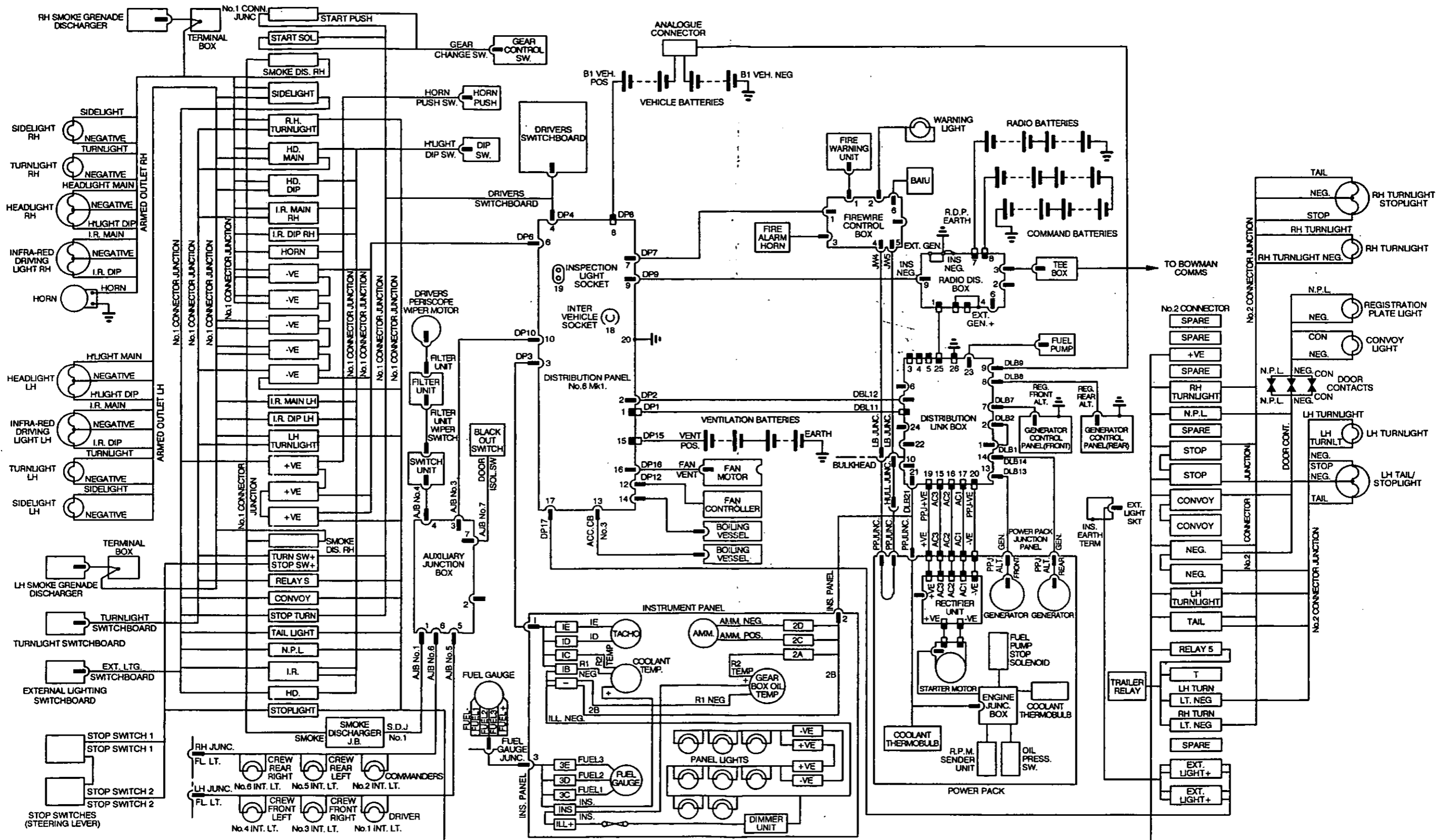

Fig 2 Block wiring diagram

430/30016

Page left intentionally blank

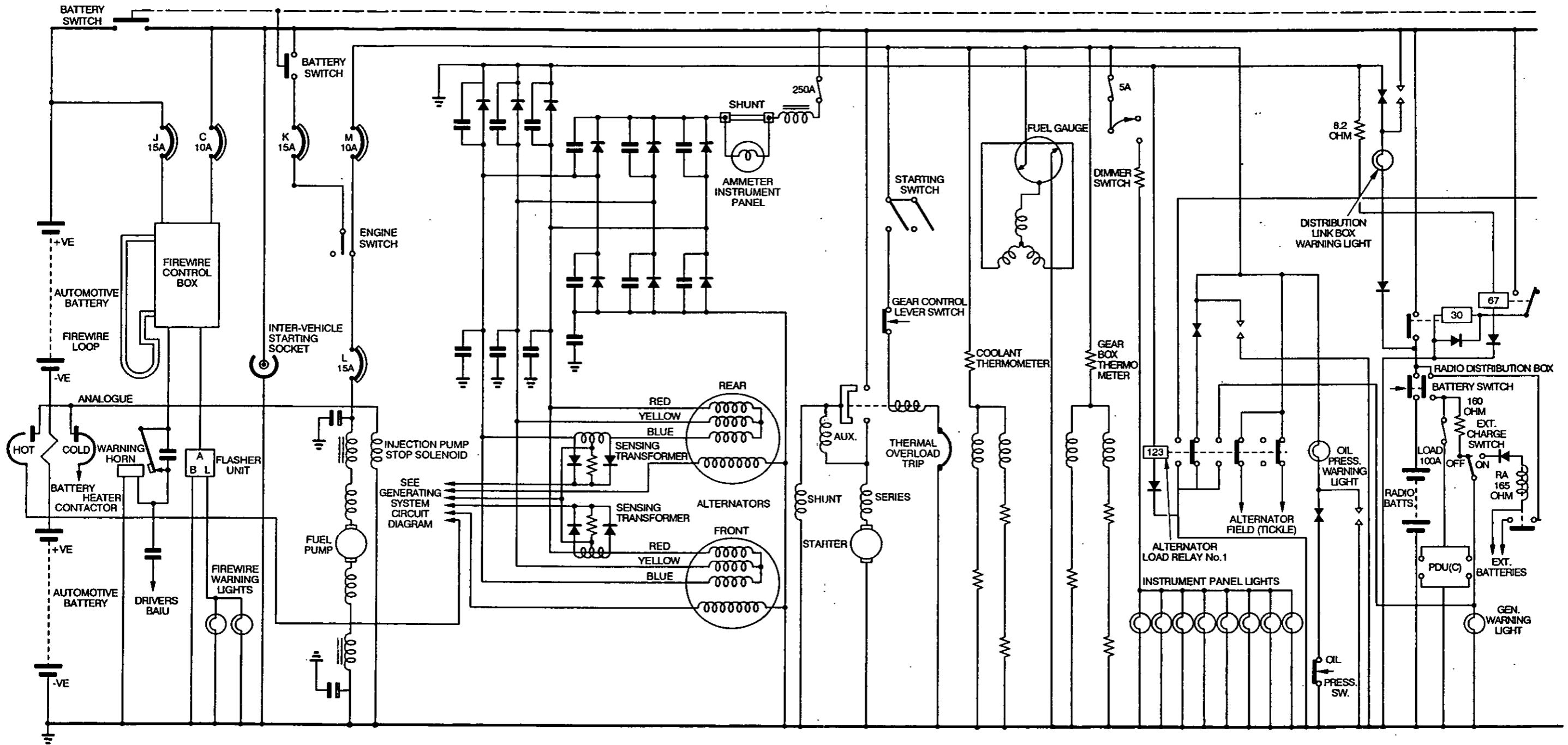

Fig 3A Schematic wiring diagram for MK 2 and 2/1 vehicles

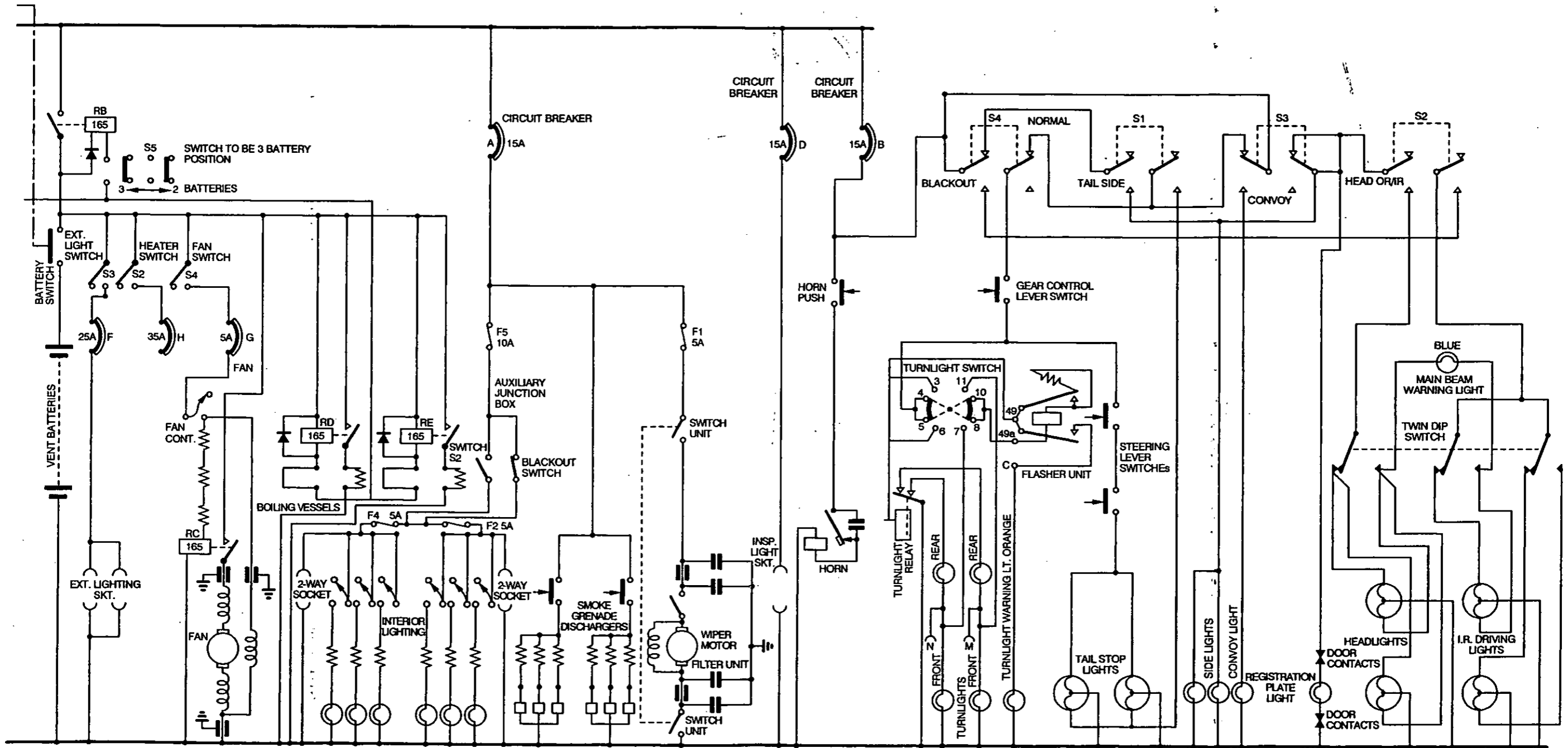

Fig 3B Schematic wiring diagram (continued)

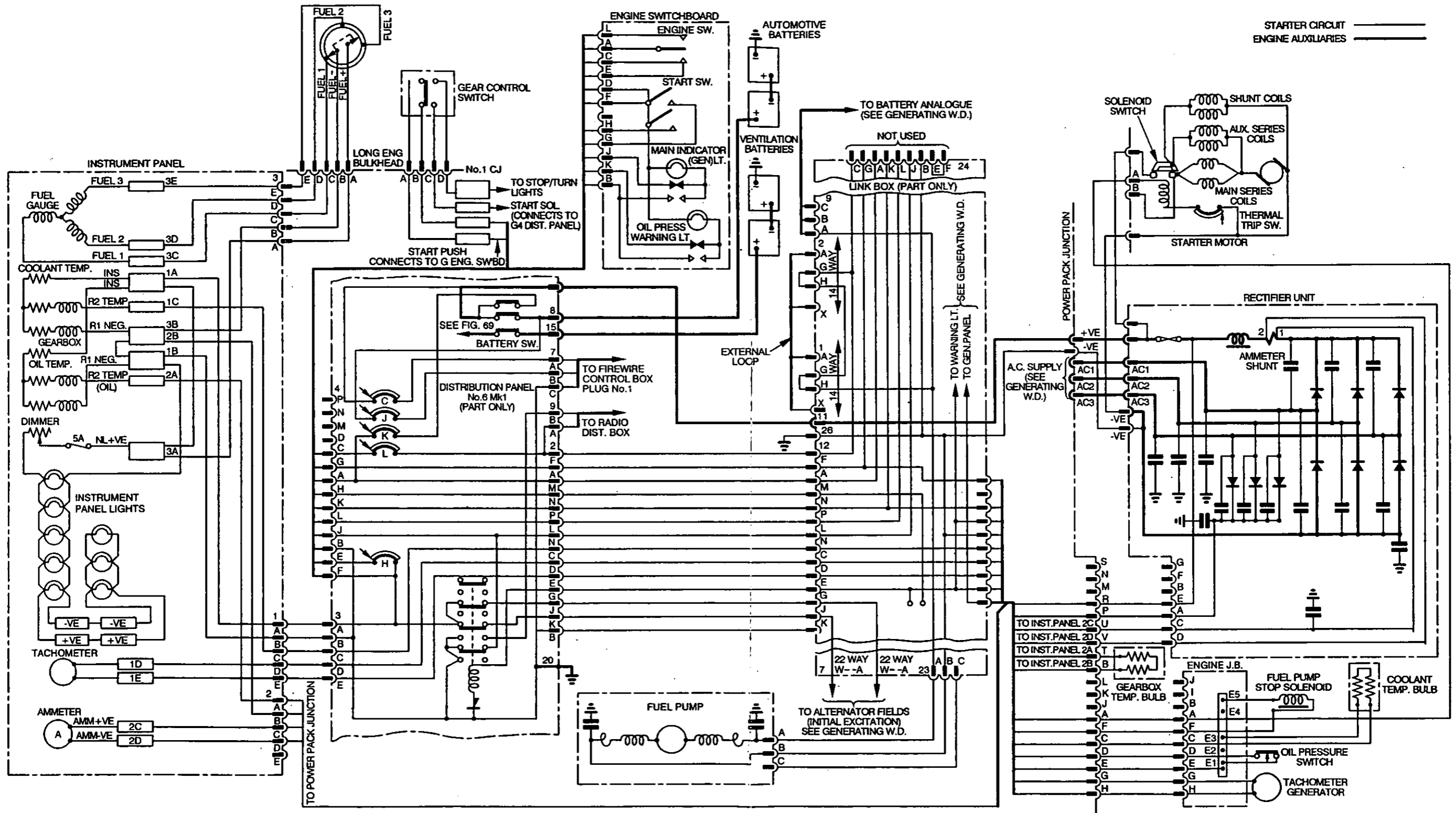

Fig 4 Engine components wiring diagram less alternators and firewire

GENERATING SYSTEM - MK 2 AND 2/1 VEHICLES

General

- 8 The generating system is an AC system and utilizes two identical alternators to give a rectified dc output to charge all batteries fitted to the vehicle.
- 9 Each alternator is controlled by a transistorised voltage regulator located on the sill to the right of the driver's seat, utilizing a voltage pulse width control system from the current output voltage variations to control the mean value of the alternator field current.
- 10 The system is dual purpose and can supply 28.5V, 200 amp dc with alternators in parallel or in power tool mode, one alternator supplying 28.5V, 100 amps dc and the second alternator supplying via the power tool transformer unit 12 kVA, 0.8 pf, 208V, 400 C/S at a constant engine speed of 2710 rev/min.
- 11 The alternators are mounted back-to-back in the alternator drive gear case, on the power pack and are fitted with driving gears coupled together and dowel located, effectively forming a single gear to mesh with the alternator drive from the power pack.
- 12 A circulatory oil cooling and lubrication system is incorporated in each alternator, fed from the power pack lubrication system; the machine is designed to operate at high temperatures, hence the necessity for a cooling system, in addition all insulation and impregnation is of special materials to withstand high temperature.
- 13 The ac output of the alternators is rectified to DC by an oil cooled rectifier unit incorporating silicon semi-conductor diodes and located in the power pack oil tank. Connections between the alternators and rectifier unit and to the main dc supplies are by means of heavy-duty plug and sockets. The generating system main fuse is located on the unit panel.
- 14 To ensure a rapid build-up of voltage on starting, a d.c. supply is fed to the alternator fields via a relay in the distribution panel. The circuit is through normally closed contacts and when the relay is energized by the alternator output via auxiliary diodes in the rectifier unit, the circuit is broken and the alternator is self-excited from the alternator phases yellow (B) and blue (C) (Fig 3A).
- 15 An ammeter located on the driver's instrument panel gives an indication of the dc output of the alternators. The ammeter is connected to a shunt located in the rectifier unit and connected in the main dc positive line.
- 16 A hand throttle is provided and can be adjusted to vary the engine speed to give a sufficient battery charging rate with the vehicle stationary.

Batteries

- 17 The automotive batteries (Fig 1(6)) are located on the sill to the right of the driver's seat, the ventilation batteries (43) on the floor to the rear of the power pack compartment and the radio batteries (69) beneath the driver's seat. Two set of additional radio (or command) batteries are mounted along the vehicle, under the Command staff sliding tables. Each set consists of two 110 Ah 12V batteries connected in series to give a 24V 110 Ah supply.
- 18 Normally the ventilation batteries are located longitudinally in the vehicle but drillings are provided in the floor plate to permit the batteries to be located transversely in the same relative position. Drillings are also provided to permit additional batteries, as required for the command role, to be accommodated down the centre of the vehicle. This is done in conjunction with AESP 2350-T-251-811 Mod Instr No 1/116.
- 19 Fig 5 details the ventilation batteries but it is typical of how all the batteries are retained. Each pair of batteries is housed in a fibre glass container (9), which in turn is located in an angle framework (10) bolted to the vehicle. The batteries sit on felt strips located on a teak framework. A clamp bar with felt strip straddles the two batteries (8) and is held by two hinged bolts (4) attached to the frame and fitted with a seating collar, a shock absorbing spring, washer and nut.

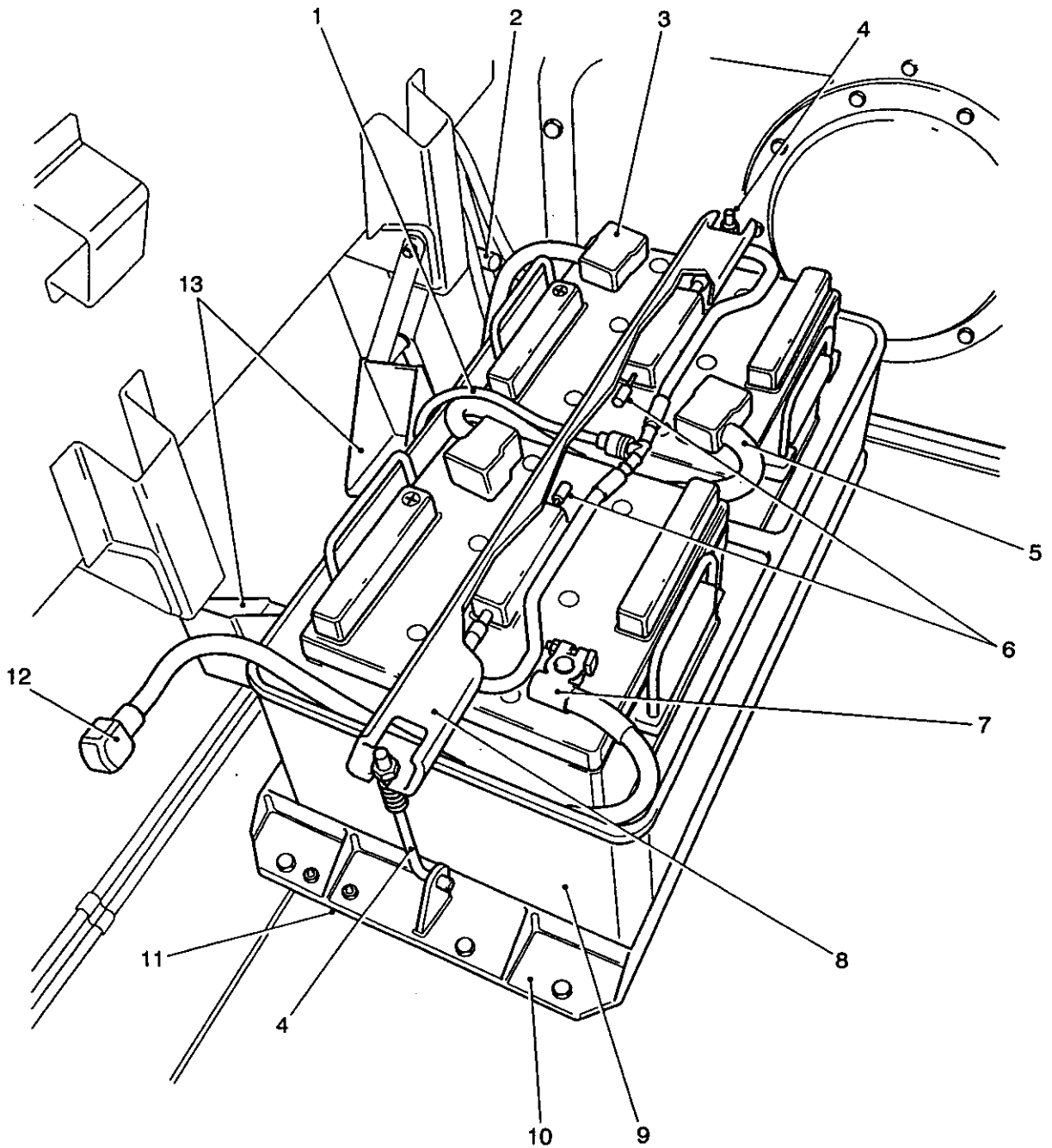

432/370a

- | | | | |
|---|----------------------------|----|---------------------------------------|
| 1 | Vent pipe | 7 | Battery Neg (-) terminal |
| 2 | Insulated stowage terminal | 8 | Battery clamp bar |
| 3 | Battery Pos (+) terminal | 9 | Battery container |
| 4 | Battery clamp bolt | 10 | Housing frame |
| 5 | Battery Neg (-) terminal | 11 | Packing strip |
| 6 | Blanking plugs | 12 | Battery Neg (-) earth connection |
| | | 13 | Commanders periscope stowage brackets |

Fig 5 Ventilation batteries and container

20 The batteries are of the lead-acid type and are supplied in a dry-charged condition; instructions for putting the batteries into service are given on the tie-on label supplied with each battery. The batteries are fully waterproofed with no visible cell inter-connectors; take-off connectors (7) are of standard split clamp type and the positive connectors are enclosed by a moulded rubber cover. To safeguard against inadvertently reversing battery connections the moulding (5) over the inter-cell connectors adjacent to the positive terminal is stamped with the + sign, and the positive terminal (3) is ringed in red.

21 A rubber strip incorporating suitably spaced plugs is used to seal the cell filler holes of each battery.

22 To permit escape of the gases during charging the cells of each battery are vented to a central block (6) having moulded-in vent tubes at either end. When in position in the battery container the inner vent tubes (1) are connected by plastic tubes to a T piece, which is connected, by another plastic tube to an inverted U tube welded to the roof of the vehicle. It is important that the vent tubes are connected as described and not in series with each other and that they are not damaged, particularly the exposed tubes on the roof and that the ends are not blocked in any way. The outer vent tubes not being used are sealed with a plastic cap to prevent entry of the gases to the vehicle; this is particularly necessary when the batteries are on charge and the vehicle is closed down. The gases liberated from a battery whilst on charge are highly inflammable and are vented to flame traps mounted on the roof of the vehicle, (one for each set of batteries), to prevent the flame of gases ignited externally (e.g. from the exhaust system) from running down the vent tube and causing the battery to explode when the engine is switched off and charging ceases.

23 An insulated terminal (Fig 1(44)) is provided adjacent to the ventilation batteries to house the battery positive connection when disconnected from the ventilation batteries.

24 The care and maintenance of lead acid batteries are detailed in AESP 6140-A-100-013.

Flame trap

25 Each flame trap (Fig 6) consists of a filter unit inside the vehicle, which is bolted to an adaptor (2) located in a hole in the roof and welded in position, the external end of the adaptor being protected by cup-shaped cover (1).

26 The adaptor is bored right through and is tapped at both ends to receive bolts securing the filter unit (4) and the top cover.

27 The filter is cup-shaped and is fabrications of porous (sintered) stainless steel plates have a pore size of 56 microns. It is enclosed by a cover (5), the filter and cover, together with polythene gaskets (6) located on either side of the filter mounting flange, being bolted to a retaining plate (3) by three slotted hexagon headed screws and spring washers.

28 A special hollow bolt (8), together with a Dowty washer (7) are used to secure the filter unit to the adaptor.

29 Welded to the filter cover is a spout with gland nut to which the PVC (Polyvinyl Chloride) battery vent tube is attached.

30 Gases generated during charging enter the space between the filter and cover, pass through the filter, up the bore of the filter retaining bolt and adaptor and out to atmosphere through a cross hole in the adaptor. If the escaping gases should ignite and run backwards, the filter effectively blocks the path of the flame and damage to the battery is thus prevented.

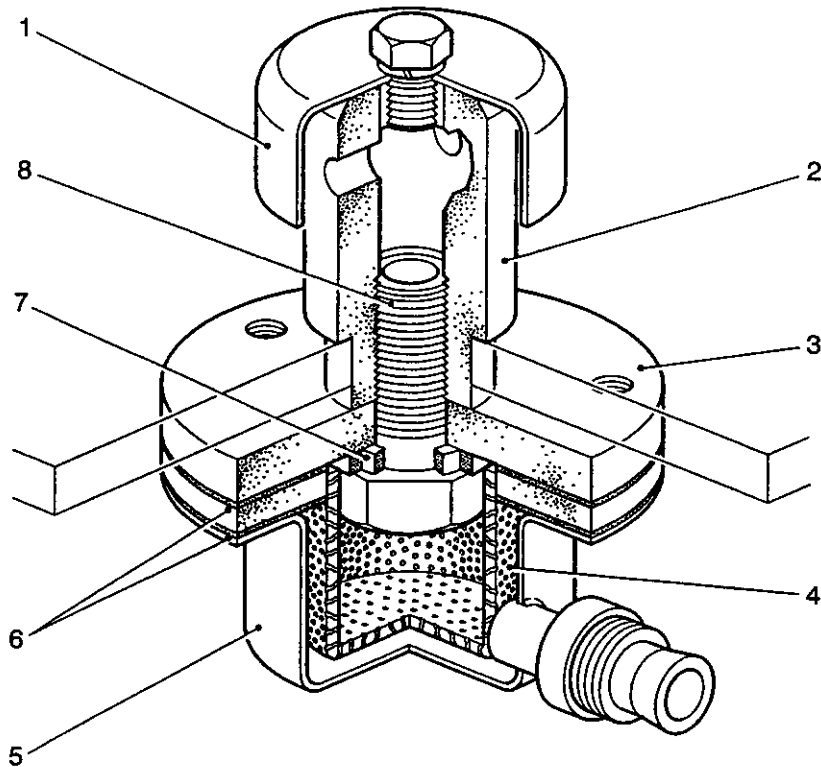

432/325

1	Cover	5	Filter cover
2	Adaptor	6	Gasket
3	Retaining plate	7	Washer
4	Filter	8	Bolt

Fig 6 Battery vent - flame trap

Analogue connector No 1 Mk 1

31 Analogue connector No 1 Mk 1 is used as the inter-connector of the automotive batteries, it assimilates the climatic conditions of these batteries.

32 It consists of a W shaped antimonial lead cast plate with integral heavy duty connecting lug in the top of each arm. The plate houses two thermostats that are bi-metal type circular sealed units and operate for tropical and arctic conditions. The tropical thermostat has normally open contacts, closing at a temperature above $49^{\circ}\text{C} \pm 3^{\circ}\text{C}$ ($120^{\circ}\text{F} \pm 5^{\circ}\text{F}$) with 3°C (9°F) differential; it is housed in a Bakelite support secured to the base of the plate. The arctic thermostat has normally closed contacts, opening at a temperature above $41^{\circ}\text{C} \pm 3^{\circ}\text{C}$ ($105^{\circ}\text{F} \pm 5^{\circ}\text{F}$) with 3°C (9°F) differential; it is housed in an aperture in the top of the plate.

33 Connections to the thermostats are made to a connecting strip located at the top of the plate and protected by a Bakelite cover secured by one screw and a locating fork, which locates in semi-circular depressions in the plate. The connections from the tropical thermostat are housed in a channel in the side of the plate.

34 In this installation, only the tropical thermostat is connected in circuit.

35 The thermostat operates in conjunction with the alternator control panels to cause a drop in the regulator voltages.

Alternator No 1 Mk 1

36 The alternator is a 3 phase, ac, fully submersible, oil cooled, reversible machine with no rotating windings, therefore, slip rings and brushes are not used. It is designed to give a main output of 3.5 kVA, 0.95 pf, 25V line current 81A at a frequency of 87.5 to 360 cps (1,750-12,600 rev/min).

37 The alternator is designed to operate at high temperature and is insulated with resin bonded glass/mica and PTFE (Polytetrafluoroethylene) impregnation to withstand rises in temperature up to 280°C (536°F) on the field windings and above this for short periods, with no deterioration of insulation.

38 The alternator is flange mounted to the alternator drive gear case on the power pack and a sealing band is fitted over the flange joint to prevent oil leaks.

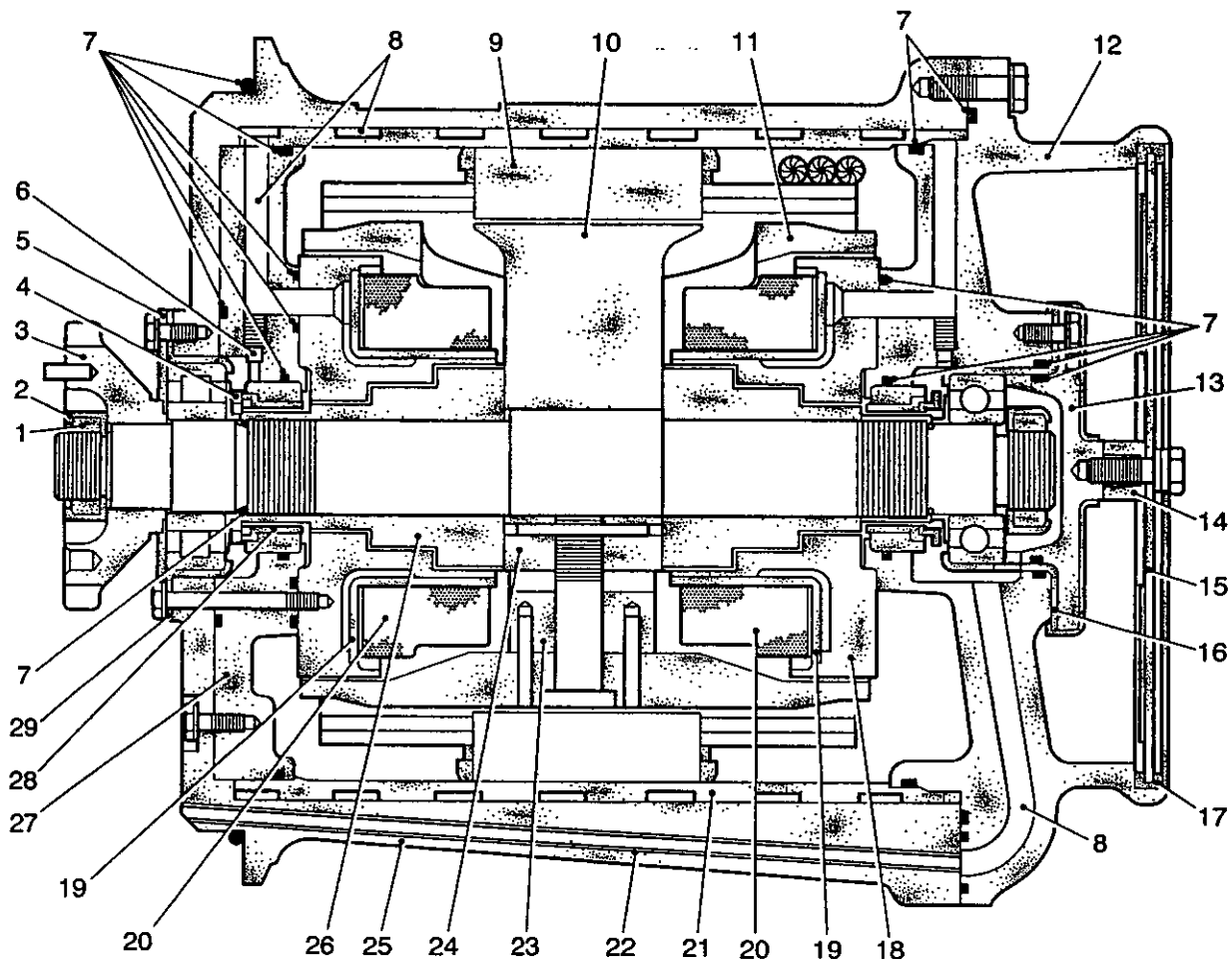

432/326

1	Lock nut	11	Rotor shell	21	Steel cylinder
2	Lock washer	12	Rear end frame	22	Oilway tube
3	Drive gear	13	Bearing clamp plate	23	Spacing block
4	Lubrication collar	14	Distance piece	24	Rotor spider
5	Bearing clamp plate	15	Cover plate	25	Main housing
6	Oil attenuator assembly	16	Bearing liner	26	Magnetic sleeve
7	'O' rings	17	Gasket	27	Oil transfer plate
8	Oilways	18	Field coil yoke	28	Oil seal
9	Stator assembly	19	Liner	29	Bearing liner
10	Rotor pole piece	20	Field coil		

Fig 7 Alternator section No. 1, Mk 1

Rotor

39 The rotor consists of a smooth cylindrical shell (Fig 7(11)) with three large equally spaced apertures to accommodate three salient pole (10) projections extending radially from a high tensile magnetic steel drive shaft to finish flush with the shell surface but isolated magnetically from it by large air spaces. The shell is fixed to the pole spider by means of non-magnetic (titanium alloy) bolts and spacing blocks. A clearance between each pole projection and its aperture is provided to ensure magnetic isolation of the rotor poles from the shell. Magnetic sleeves (26) of 'three step' form abut the rotor spider at either side and are retained in position by collars screwed on threaded sections of the rotor shaft and dowelled in position.

40 The rotor shaft is carried on a roller bearing at the drive (front) end and a ball bearing at the rear end; the shaft is fitted with a lockwasher and nut to retain the ball bearing.

Drive gear

41 The drive end of the rotor shaft is shaped to provide a 60 degree polygon section on which is mounted a drive gear (Fig 7(3)) secured by a nut (1) and lockwasher (2). To ensure that the correct phase relationship is maintained between the two contra-rotating alternators, the front face of the gear has a dowel and pin arrangement, the position of which is aligned with the position of a chosen phase on the rotor. To aid the lining up of the alternators when being fixed in position, the two gear teeth diametrically opposite the dowel and hole are chamfered. There is also a visual assembly mark on the alternator mounting flange which when lined up with a corresponding mark on the gearbox ensures that the oilways are in line.

Stator and body

42 The stator (Fig 7 (9)) consists of a welded stack of magnetic steel sheet stampings wound with a 3 phase star connected main winding; the assembly is housed in a steel liner (Fig 8(4)), pressed into an aluminium body (1), provided with a mounting flange at the drive end. The stator stack is retained in position by three screws entered from the outside of the body. Each screw is fitted with a sealing bush, locking and flat washer.

43 The steel liner is provided with helical slots on the outer surface to form oil ways (Fig 7(8)) between the body and liner. The slots terminate in four outlets two at the front (Fig 8(3)) and two at the rear (5) of the body to serve as inlets and outlets for oil circulation.

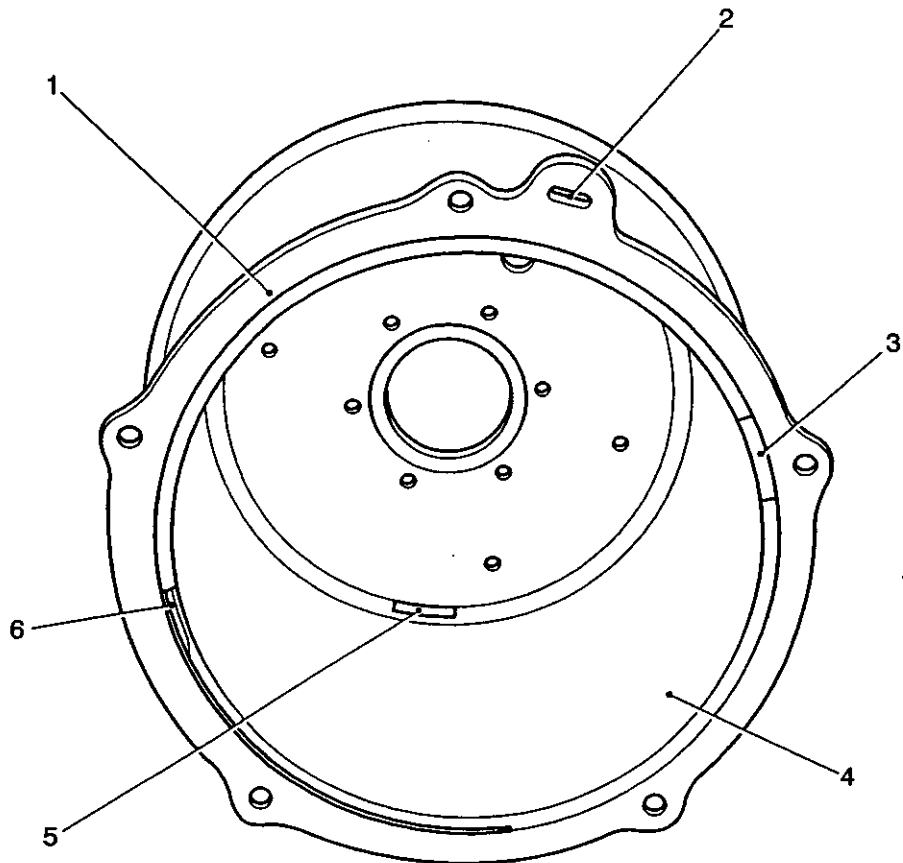

432/388

- | | | | |
|---|---------------|---|------------|
| 1 | Body | 4 | Liner |
| 2 | Drain channel | 5 | Rear slots |
| 3 | Front slots | 6 | Front slot |

Fig 8 Alternator - body assembly

- 44 Cast integrally with the body is the drive end shield (DE Shield) for housing the roller bearing.
- 45 An oil drain channel (Fig 7(22)) is formed in the body casting, extending from an outlet in the drive end mounting spigot to a corresponding outlet in the body rear face.

Field

46 Two stationary field yokes (Fig 7(18)) of high permeability alloy are bolted to the end shields and project inside the rotor shell. The yokes are of three step form to align with the magnetic sleeves of the rotor, a small gap separates the sleeves from the yokes. A similar gap exists between the outer face of the yoke and the inner face of the rotor sleeve. A field coil (Fig 7(20)) is carried on each yoke; these are connected in series with each other. Each yoke is provided with a cooling passage and an inlet and outlet for oil circulation.

Drive endplate

47 The drive (front) endplate is secured by three screws to the inner face of the body drive end. A sealing ring is housed in a recess round each screw entry. A recessed housing in the plate carries a resilient mounted seal (Fig 7(28)) to prevent oil leakage into the rotor tunnel. The recess also serves as an oil reservoir for the drive end roller bearing.

48 An oil way in the endplate permits oil flow to the DE field yoke for cooling and via a branch-way to the roller bearing for lubrication. To reduce oil flow, the branch oil way to the bearing is fitted with a restrictor valve consisting of a plug with a square form helix, pressed into a threaded barrel to screw into the oil way.

49 The resilient mounted seal (Fig 9) consists of an outer steel ring (2) housing a spring-loaded carbon faced inner ring (1); this inner ring is in contact with a carbon faced collar (3). The outer ring is housed, together with a sealing ring (Fig 7(7)) in the end plate and the rotor shaft extends through the inner ring with a clearance between. The carbon faced collar is free to rotate and incorporates two rings bonded by a resilient material. This construction ensures that when the bearing and seal are clamped, the carbon faces maintain contact, so that no distortion takes place.

50 Oil seals are fitted between the mating surfaces of the drive endplate and body steel liner and between the endplate and end shield round the bearing housing.

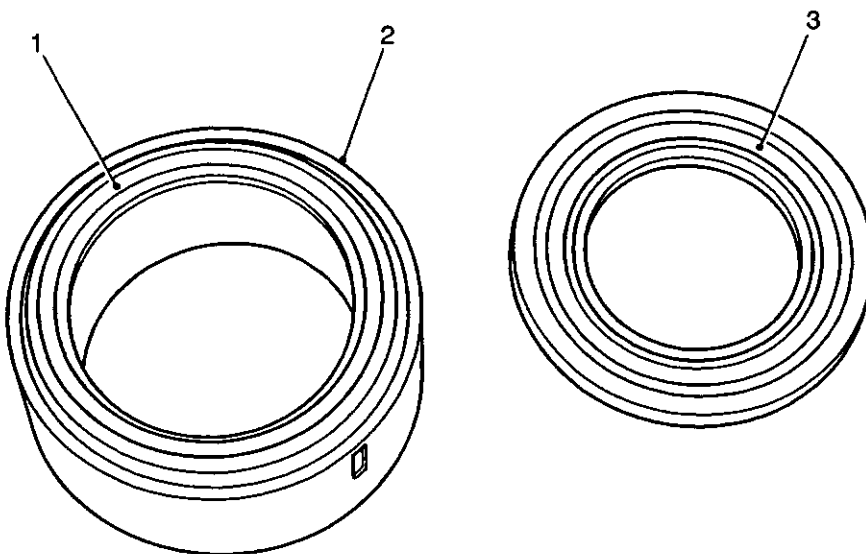

1 Inner ring 2 Outer ring 3 Collar

Fig 9 Alternator resilient mounted seals

Rear end shield

51 The rear end frame (Fig 7(12)) is spigot located to the alternator body and secured by five screws. Two oil seals are located, one in the spigot and one between the mating surfaces of the end shield and body.

52 A ball bearing and resilient mounted seal are carried in a housing located centrally in the shield; a sealing ring is fitted in a recess between the housing and end shield. A spigoted retaining plate is also located in the housing, the spigot being fitted with an oil seal. The plate is secured to the end shield by three screws. A neoprene cap is fitted over the plate.

53 Two oil ways are cast integrally in the end shield. One supplies the field yoke and bearing, via a branch-way fitted with a restrictor valve, and the other is connected to the drain channel. An oil seal is fitted in a recess round the oil way in the mating face of the end shield.

54 Internal connections from the alternator are made to a terminal block located in the end shield. Cables connect from the terminal block to a 7-pin plug housed in the end shield provided for external connection to the alternator. A circular cover plate secured to the end shield by a centrally located screw encloses the terminal block and cables.

55 A connector union, located adjacent to the 7-pin plug, is provided for connection to an overspill oil pipe.

Cooling system

56 Oil from the alternator drive gear case enters the alternator via an inlet oil port (Fig 10(2)) located in the body drive end and flows through an oil way to a cooling passage that partly encompasses one field yoke. A bleed tube passes a small amount of oil from the oil way to lubricate the roller bearing. The main oil flows from the field yoke through one half of a two start cooling helix formed by the slots between the starter housing and steel cylinder, to the second field yoke and back through the other half of the cooling helix and via a return oil port (1) in the body drive end of the gear case. Oil is bled off from the main supply to lubricate the ball bearing and this oil is returned to the gear case by a drain channel embodied in the alternator body.

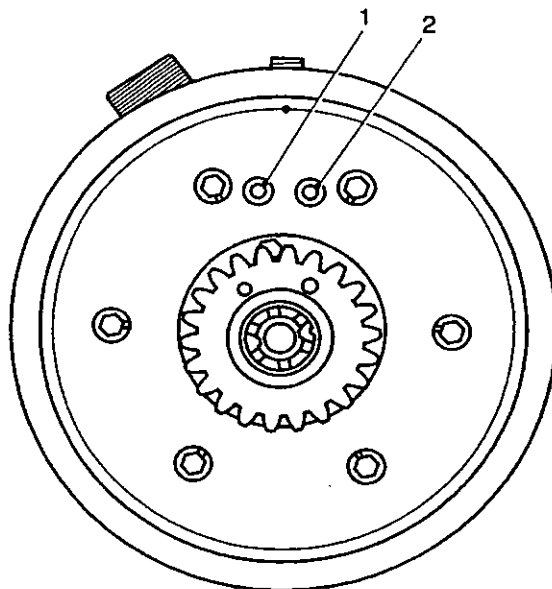

1 Outlet port

2 Inlet port

Fig 10 Alternator oil inlet and outlet ports

432/386

57 When in position in the alternator drive gear case (Fig 11(1)), the inlet and return oil ports each locate on adaptor pipes (2) and (3) located in the gear case and to ensure correct alignment of the oil ways, a register mark is provided on the alternator mounting flange, to align with a similar mark on the drive gear case.

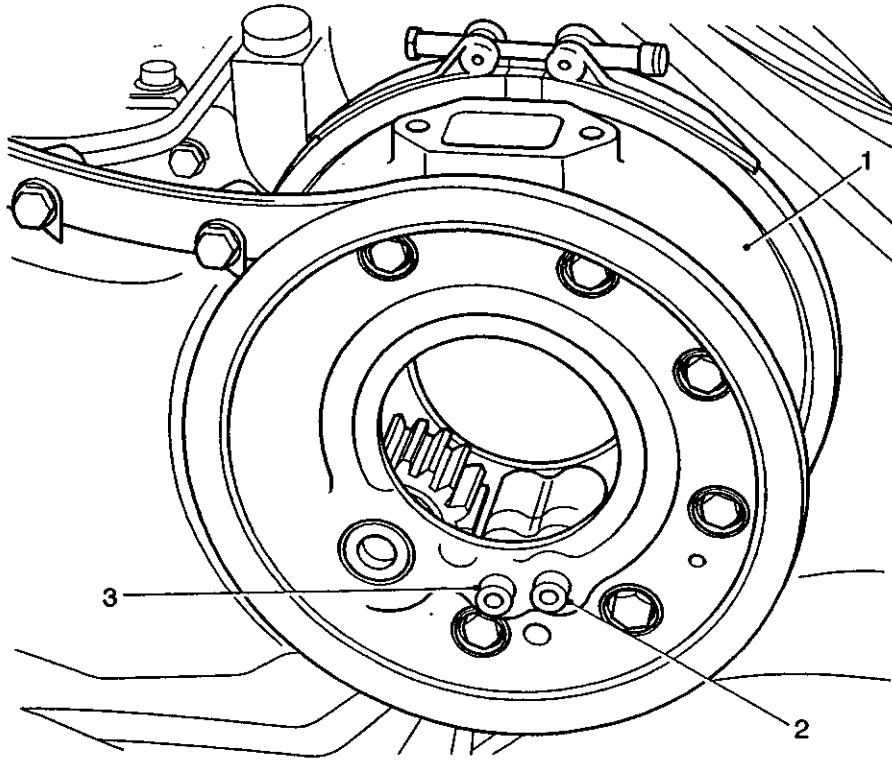

432/191

1 Drive gear case 2 Inlet adaptor pipe 3 Outlet adaptor pipe

Fig 11 Alternator drive gear case

Operation

58 A unidirectional flux is produced in the field windings (Fig 12(5)) initially by excitation with dc voltage from the vehicle supply and by self-excitation when the alternator is delivering output.

59 The field flux passes through the air gaps between the stepped sections on the rotor shaft and field yokes (1) to meet in the centre of the drive shaft; each field coil sets up half the total field flux. From the shaft centre it is carried radially outwards through the three rotor spider arms (4), which can be regarded as north poles.

60 The flux from the spider arms crosses the stator/rotor air gap to the stator laminations (2) thus linking the stator conductors. Flux then re-crosses the stator/rotor air gap and enters the solid sections of the rotor cylinder (3) between the apertures. These solid sections can be regarded as south poles. The flux separates and travels axially towards each end of the rotor cylinder and finally crosses the air gap between the cylinder and field yokes to complete the magnetic circuit. As the cylinder, the south pole, surrounds each spider arm (north pole), the flux returning to it follows two parallel paths to complete the magnetic circuit. Thus, the machine is effectively six pole and gives a 3 phase output.

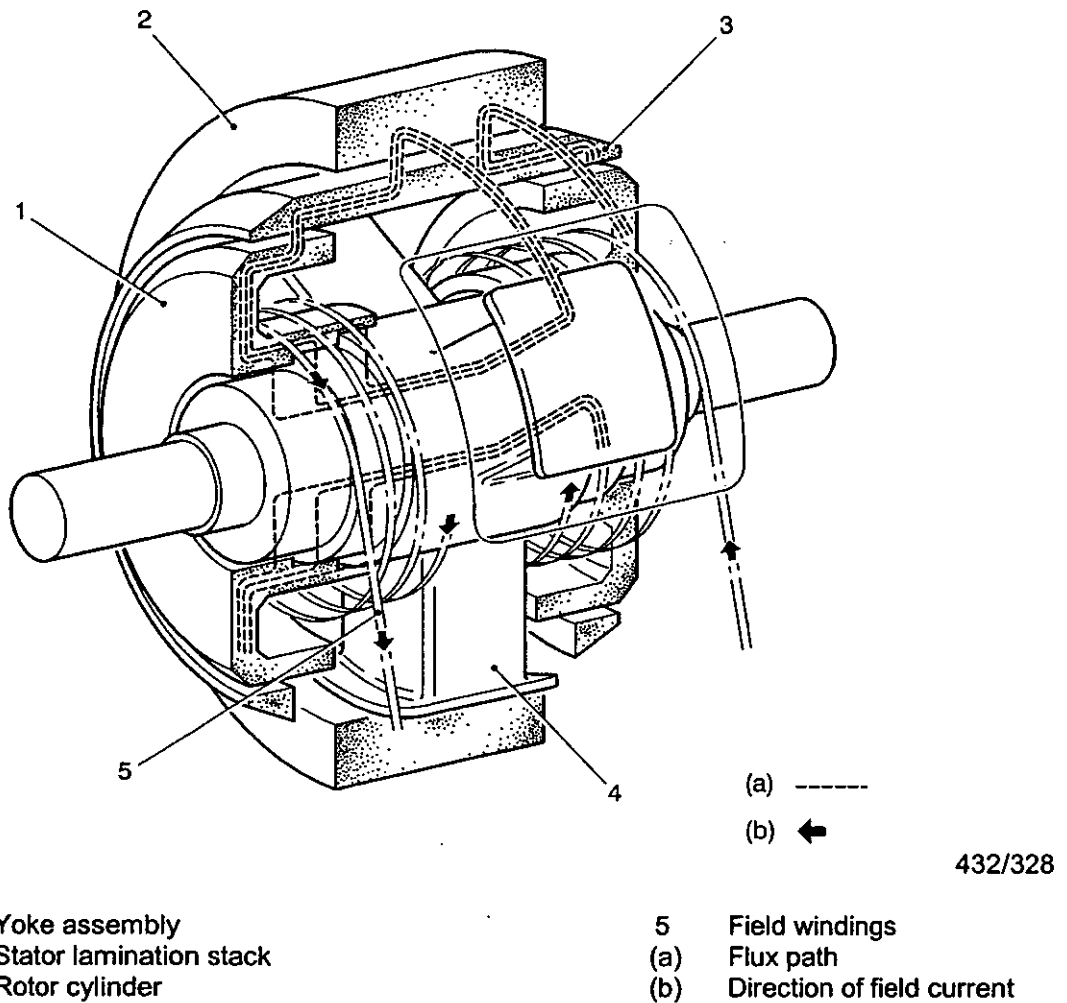

Fig 12 Alternator diagram of operation

Control panel alternator No 1 Mk 1

61 The control panel (Fig 13) consists of a metal case housing three vertically and one horizontally mounted component panels and two silicon controlled rectifiers. The vertical panels are identified Panel 1 (1), Panel 2 (2), and Panel 3 (3) respectively.

62 The waterproofed case is fitted with a cover secured by nine screws and a sealing gasket (Fig 13(5)) is located in a recess in the case.

63 External connections are made to a 22-pin plug (6) located in the case side.

Panel 1

64 Panel 1 carries a two stage amplifier circuit to which the alternator sensing voltage is fed; the voltage is compared with a reference voltage obtained from a Zener diode.

Panel 2

65 Panel 2 carries the trigger circuit for firing the Silicon Controlled Rectifiers (SCR's), a delay circuit for pulse width control and a synchronizing circuit for the SCR's are carried on this panel.

Panel 3

66 Panel 3 carries the field overheat protection and current limiting circuits.

Panel 4

67 Panel 4 (Fig 13(7)) (horizontally mounted) carries smoothing capacitors, diodes associated with the input sensing circuit and a magnetic amplifier. A terminal block (4) located on top of the panel serves as a connection point for the component panels and 22-pin plug.

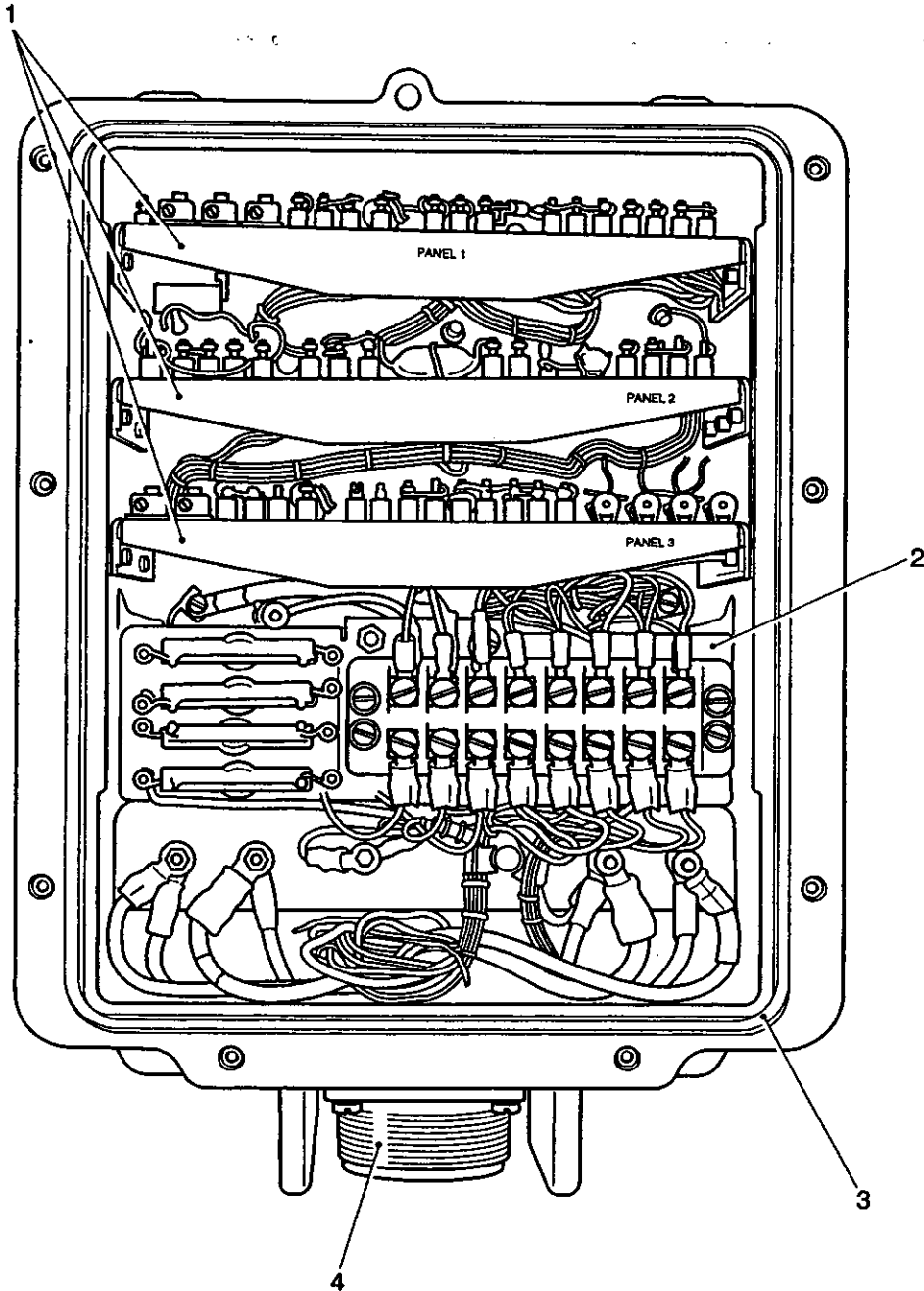

432/330

- | | | | |
|---|----------------|---|----------------|
| 1 | Panel No 1 | 5 | Sealing gasket |
| 2 | Panel No 2 | 6 | 22 pin plug |
| 3 | Panel No 3 | 7 | Panel No 4 |
| 4 | Terminal block | | |

Fig 13 Control panel No. 1, Mk 1 cover removed

Silicon controlled rectifiers

68 The silicon controlled rectifiers (SCR's) are mounted on insets located one at either side of the control panel case, which also serves as a heat sink. Cover plates secured by screws on the outside of the case protects the SCR's.

69 Each SCR is of tubular metal case construction, provided with a threaded stud at one end and a flexible connector at the other. The rectifier body is insulated from the case by a bush and insulating washers and is secured in position by a nut with a spring washer entered on the stud. A connecting tag inserted under the spring washer serves as one connection point to the rectifier, the other being the flexible connector, lead washers are inserted between the rectifier body and insulating washer to ensure even seating and aid heat dissipation.

70 A silicon controlled rectifier is similar to a conventional semi-conductor diode except that it will not conduct a forward current until a small signal is applied to a trigger electrode. Once the trigger signal has operated for the SCR to conduct, it will do so even if the trigger signal is removed, provided sufficient current flow is maintained through the rectifier.

Operation

71 Field excitation. The supply for field excitation is derived from Phases Yellow (B) and Blue (C) (Fig 14) on the ac side of the rectifier unit main diodes. SCR1 is connected to Phase Yellow (B), SCR2 to Phase Blue (C). As the voltage on Phase Yellow (B) increases positively with respect to Phase Blue (C) conduction occurs through SCR1 (i.e. triggered), the alternator field and diode 6 back to the generator star connection. At the peak positive voltage of Phase Yellow (B), conduction changes to main diode 4 (Phase Red (A) is negative going, Phase Blue (C) positive going). Conduction continues through SCR1 until Phases Red (A) and Yellow (B) are equally negative. SCR1 is now switched off (anode voltage zero) and SCR2 switched on to conduct the positively rising voltage on Phase C with respect to Phase Yellow (B). Conduction takes place through SCR2 the alternator field and diode 5 and continues in this manner until both Phase Blue (C) and Phase Yellow (B) are equally negative and SCR2 switches off, allowing the complete cycle to start again. The field receives a pulsed voltage waveform. The maximum conduction period for SCR1 is 240 degree and if SCR2 was allowed to conduct together with SCR1, then a short circuit would exist between Phase Yellow (B) and Blue (C) at the time when the voltage on Phase Yellow (B) begins to fall to zero. Therefore, the conduction period of SCR2 is restricted to a maximum of 120 degree by the timing of the trigger signal applied. The method of deriving the trigger signal is described at Voltage Regulation, Para 72. The diode connected across the alternator field permits use to be made of the power stored in the inductive field which reduces the current to be handled by the SCR's. The diode also reduces inductive voltages across the field, thus protecting the SCR's.

72 Voltage regulation A 28.5V reference voltage is derived from the positive bus bar in the distribution link box is applied via pin B of the regulator unit to a resistance chain (Fig 18a), RV_3, R_1, R_2, R_3, R_2 . A smoother portion of the voltage is applied to the base of transistor T2 and compared with a reference voltage established across the Zener diode MR4 in the emitter circuit. An increase of the 28.5V reference causes a large increase in the collector current of T1 and a consequent reduction of the voltage between T2 collector and negative (i.e., the voltage of the base of T1). This increases the base current of T1, which, in turn, raises the potential of the T1 collector. Thus the base current of T3 is reduced, therefore, reducing the current passed by the collector, which is the charging current for capacitor C13, resulting in a longer charging up time. When the voltage across C13 reaches 60 per cent of the voltage at the collector of T8, the uni-junction transistor T4 will conduct and apply a pulse (formed by transistors T8 and T9) to the transformer TR1. This applies a trigger signal to SCR1. By lengthening the charging up time to C13, this signal is delayed, therefore, the pulse width (Fig 17) i.e., some part of the 240 degree conduction period of the voltage developed by SCR1 is reduced. This results in a lower value of mean current fed to the alternator field, hence reducing the regulated voltage output. Thus, the point at which the SCR conducts is dependent upon the reference voltage, and the mean current flowing through the alternator field, will restore the output voltage of 28.5V. SCR2 performs a similar function and is synchronized to SCR1 by T5, T6 and T1 to conduct over half of the conduction period as demanded by the field, i.e., some part of the 120 deg conduction period. The pulse output to SCR2 is obtained from TR2 and pulse delay from C14. The 120 degree conduction period raises the mean voltage that can be applied to the alternator field and gives a smoother field current. The SCR's are switched off when the ac voltage falls to zero every 180 deg irrespective of trigger signal, i.e., the SCR's only conduct when the relevant phase voltage is rising positive.

73 Field overheat protection. In order to prevent excessive temperature rises of the field winding causing damage to the PTFE insulation, a field overheat protection circuit is incorporated in the alternator control panel.

73.1 The resistance of the field winding varies according to its temperature, therefore, if a signal proportional to field voltage is divided by a signal proportional to field current, a signal proportional to field resistance is obtained and this is used to reduce the field current in the event of excessive field temperature.

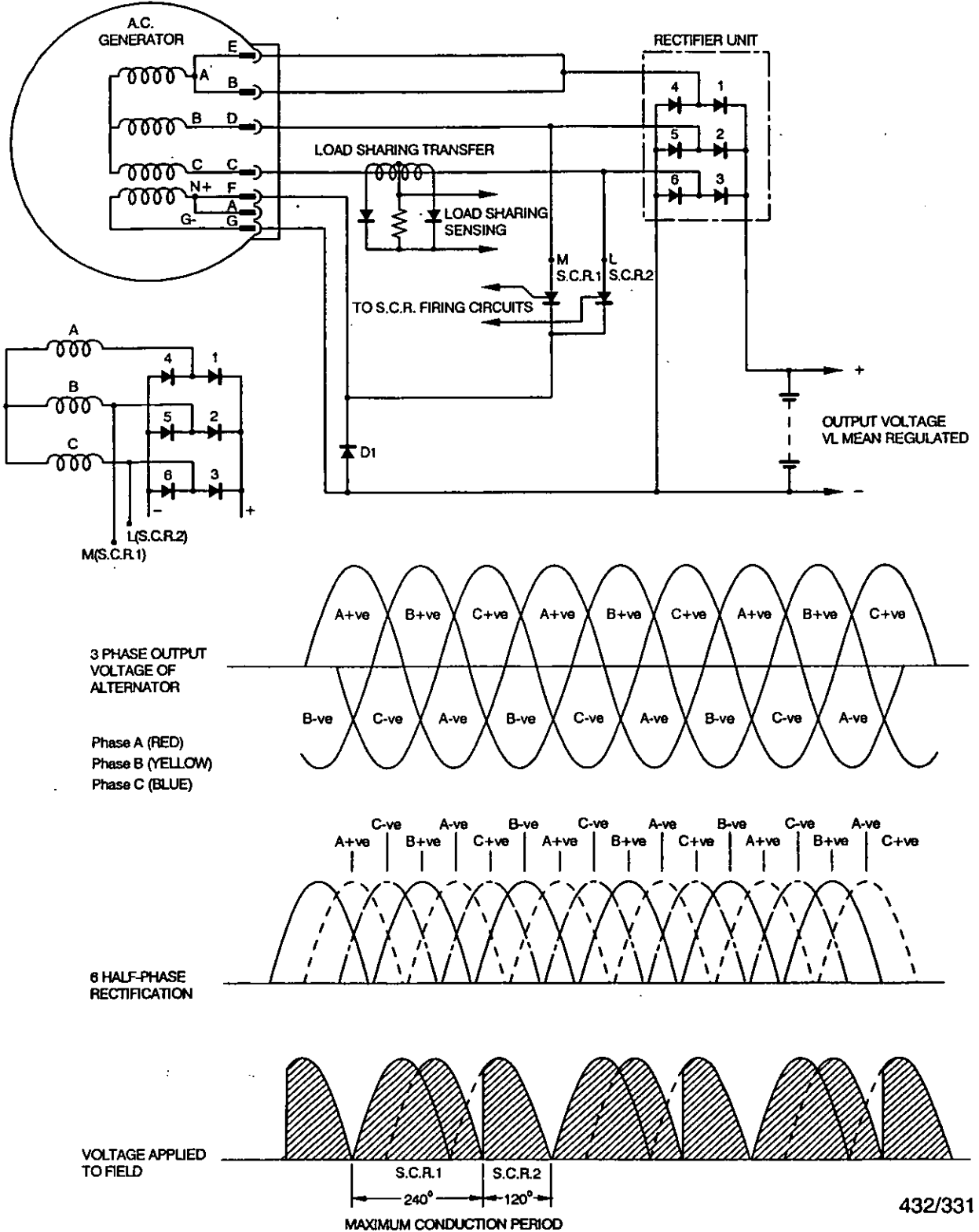

Fig 14 Control panel field excitation circuit

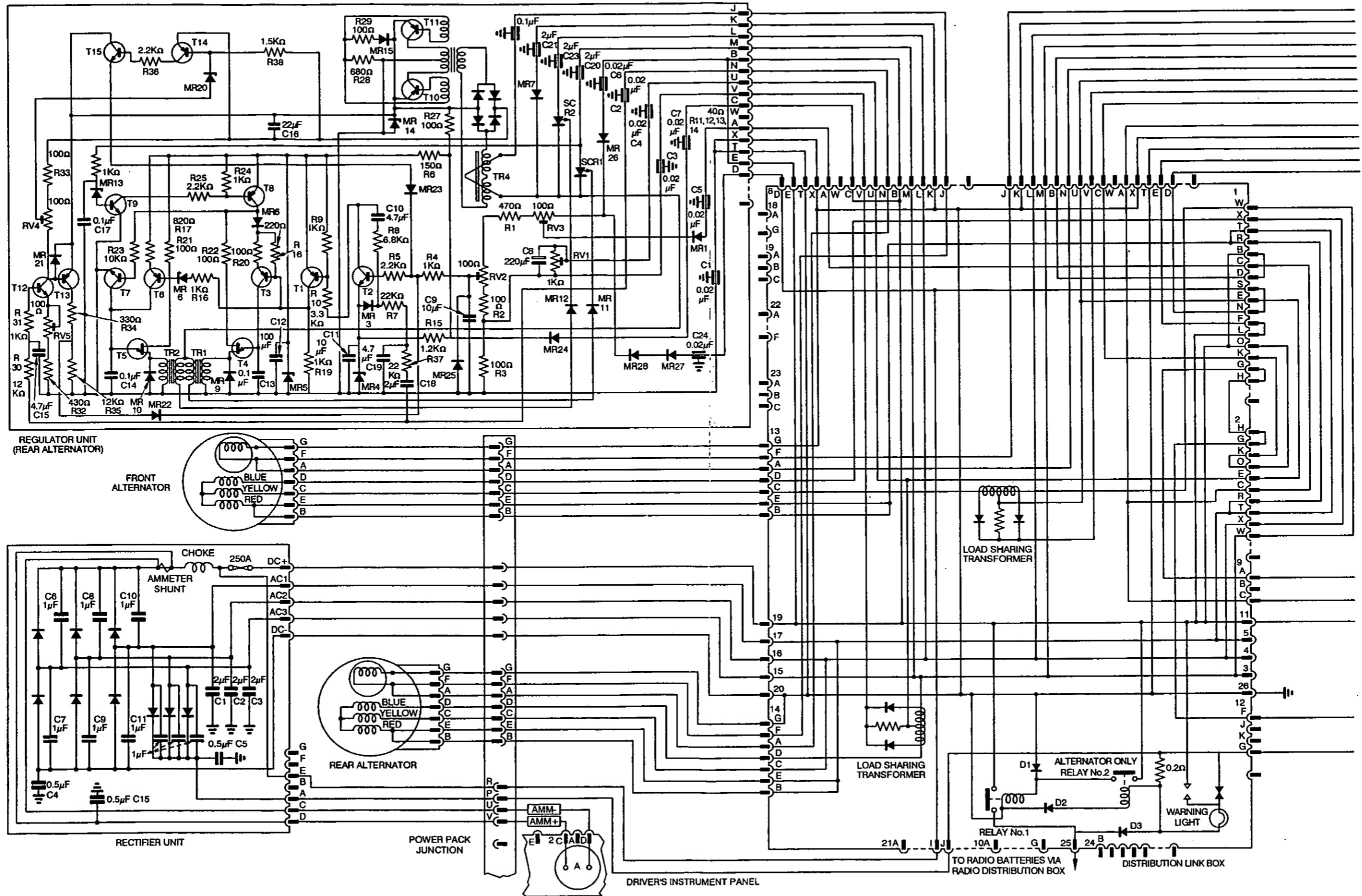
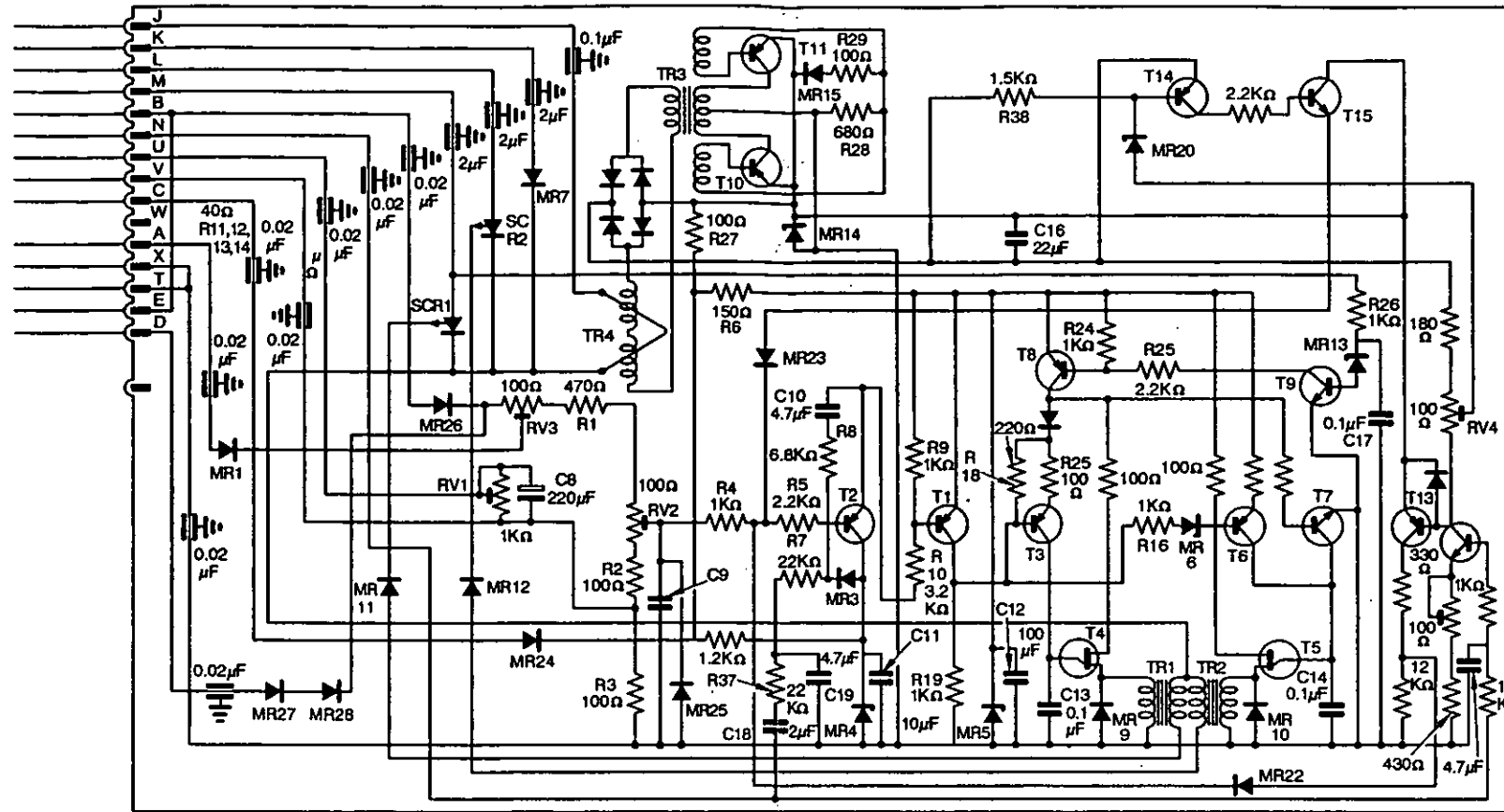

Fig 15A Charging circuit wiring diagram



REGULATOR UNIT (REAR ALTERNATOR)

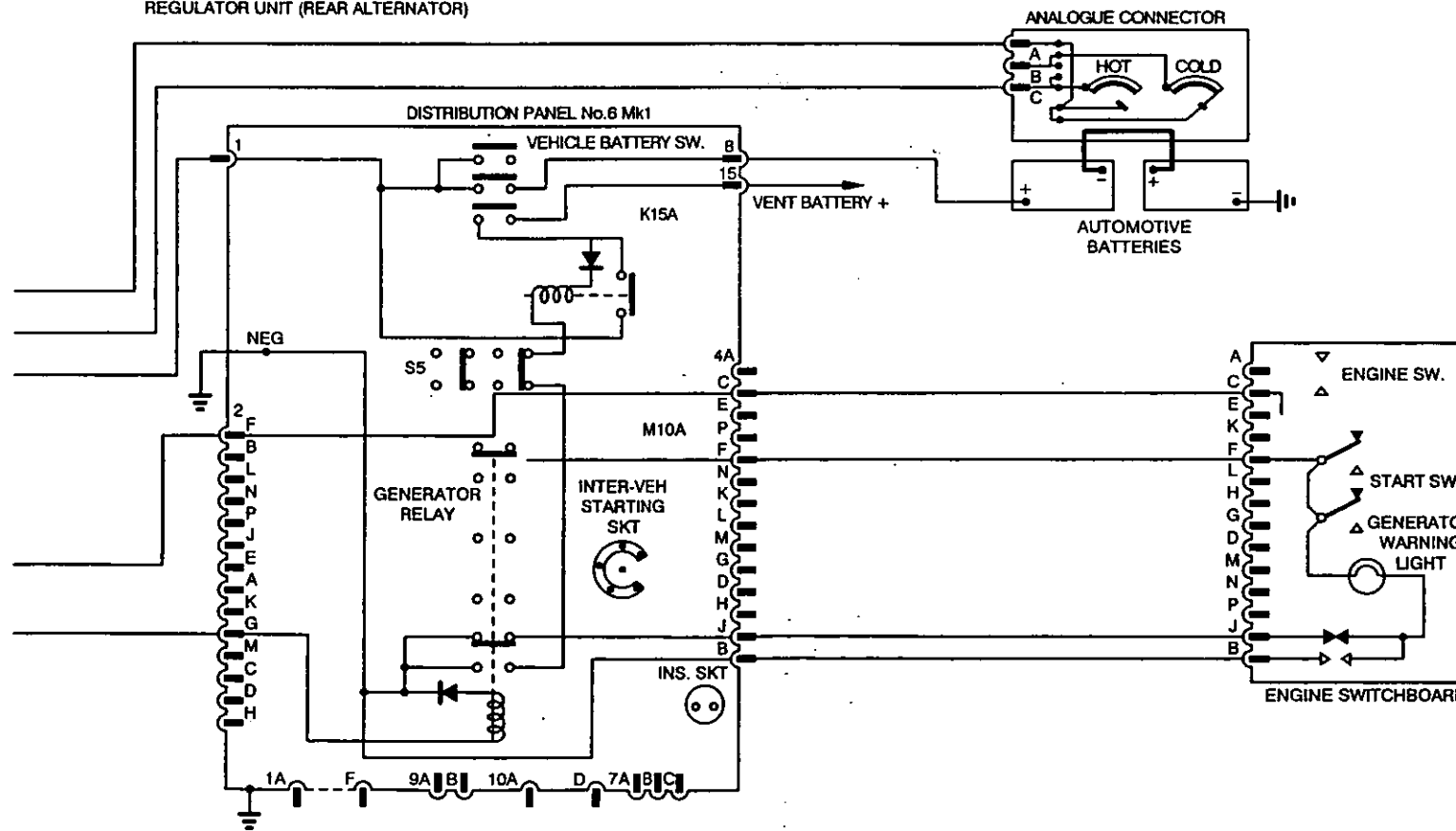

Fig 15B Charging circuit wiring diagram (continued)

73.2 The field is sensed by the control winding of a series magnetic amplifier TR4 and an output is developed proportional to the mean field current. This output is rectified by the diodes MR16, MR17, MR18, MR19, in a bridge connection, and fed to the collector of T12 via R33 and RV4. The magnetic amplifier is driven by a 1 kc/s square wave oscillator comprising T10, T11, TR3, R28 and R29 with its stabilized input supply obtained from the voltage across Zener diode MR14.

73.3 The field voltage is sensed in the alternator and fed via pin A of the alternator plug, distribution panel, pin N of the alternator control panel to the smoothing network R30, R31, C15 and thence to the base of T12. The emitter current and hence the collector current of T12 is proportioned by RV5 such that when the alternator field resistance reaches a predetermined value, the current demanded by the collector of T12 is greater than the current output of the magnetic amplifier. Under this condition the excess current required by T12 is supplied via the base of T13, therefore, the base current of T13 and hence its collector is proportional to the ratio of voltage divided by current, i.e., resistance.

73.4 A voltage proportional to T13 collector current, i.e., proportional to field resistance is taken from the junction of R34 and R35 in the collector circuit of T13 and fed via a diode MR22 to the junction of R4 and R5 in the base circuit of T2 raising its base-emitter voltage so that the collector current of T2 is increased and the mean field current is reduced as described in Para 71, thus causing the overheated machine to shed its load allowing the field windings to cool. When the field winding temperature falls below a predetermined value the limiting signal supplied to the base of T2 is removed and normal regulation takes place.

74 Field current limiting. The control system tends to achieve the regulated voltage under all conditions. Under certain conditions, e.g., alternator overloaded or operation in sub-zero temperatures when the field resistance is low, the heavy current could flow through the field windings. To limit the maximum field current to approximately 30A at any time, a current limiting circuit is incorporated.

74.1 The voltage at the base of T14 is held constant by a Zener diode MR20 and a voltage proportional to the field current is applied via a potentiometer RV4 and R33 to the emitter of T14. Thus, T15 will not conduct until the emitter voltage of T14 reaches a predetermined value corresponding to the maximum allowable field current. When T15 conducts, i.e., when the voltage applied across the potentiometer in the emitter of T14 exceeds that of the Zener diode, the resulting voltage is applied via diode MR23 to the junction of R4 and R5 in the base of T2 to limit the field current to 30A approximately.

75 Load sharing. Load sharing transformers located in the Distribution Link Box are connected to one line of the AC output of each alternator and produce a DC voltage proportional to the AC in the line. The voltage is fed to the respective regulator and a smoothed proportion is applied via a potentiometer to the resistance chain R2 and R3. Both load sharing circuits are pre-set by a potentiometer RV1 in each regulator to give the same output for a particular line current so that differences in line currents affect the voltage reference input fed to T2 in each regulator in such a way that the current produced by one alternator falls while the current of the other rises until the load is shared approximately equal.

76 Stability. A resistor and capacitor feedback network consisting of R7, R37, C18, C19 is connected between the base of T2 and the field voltage reference line to suppress any random oscillations that occur in the field voltage due to changes in load speed and temperature.

77 Dual sensing. The positive reference voltage for the control panels is normally obtained from the positive bus bar in the Distribution Link Box. Should this reference voltage fail, e.g., the main fuse blown, the regulator will not control the alternator output voltage and damage to the main rectifier diodes could result. An alternative reference voltage is obtained from the dc positive output of the Rectifier Unit at a point preceding the main fuse, and is fed to Pin D of the control panel. Blocking diodes MR26, 27, 28, prevent circulating currents between the two reference lines and adjust the voltage drop such that under normal conditions the voltage reference is taken from the Distribution Link Box, the Rectifier Unit being back biased.

78 Battery overheat protection. The automotive batteries are protected against overheat by a thermal switch incorporated in the Analogue Connector No. 1 Mk 1.

78.1 A 24V dc supply from the distribution panel, controlled by the engine switch is connected to one contact of the tropical thermostat (Fig 15). From the other contact a circuit is made to Pin A of the plugs on both alternator control panels. When the contacts close, i.e., at a temperature above 49 deg C \pm 3 deg C (120 deg F \pm 5 deg F), the positive dc supply is applied to the resistance chain R₁, R₂, R₃, RV₂ and RV₃, the proportion being preset by RV₃. This voltage is applied via R₄ and R₅ to the base of T₂ reduced by the regulated voltage.

Rectifier unit No 1 Mk 1

79 The rectifier unit (Fig 16) consists of a die cast aluminium top panel (1) carrying two panels (Fig 17(7)) spaced apart on hexagonal pillars (2) to form an upper and lower compartment. The upper panel comprises a metal and an insulating plate and the lower panel an insulating plate.

80 The unit is oil cooled and is mounted by the top panel in the power pack oil tank, the upper and lower compartment being immersed in the oil. An oil pipe (Fig 16(3)) terminating in a connection in the top panel, extends through both compartments.

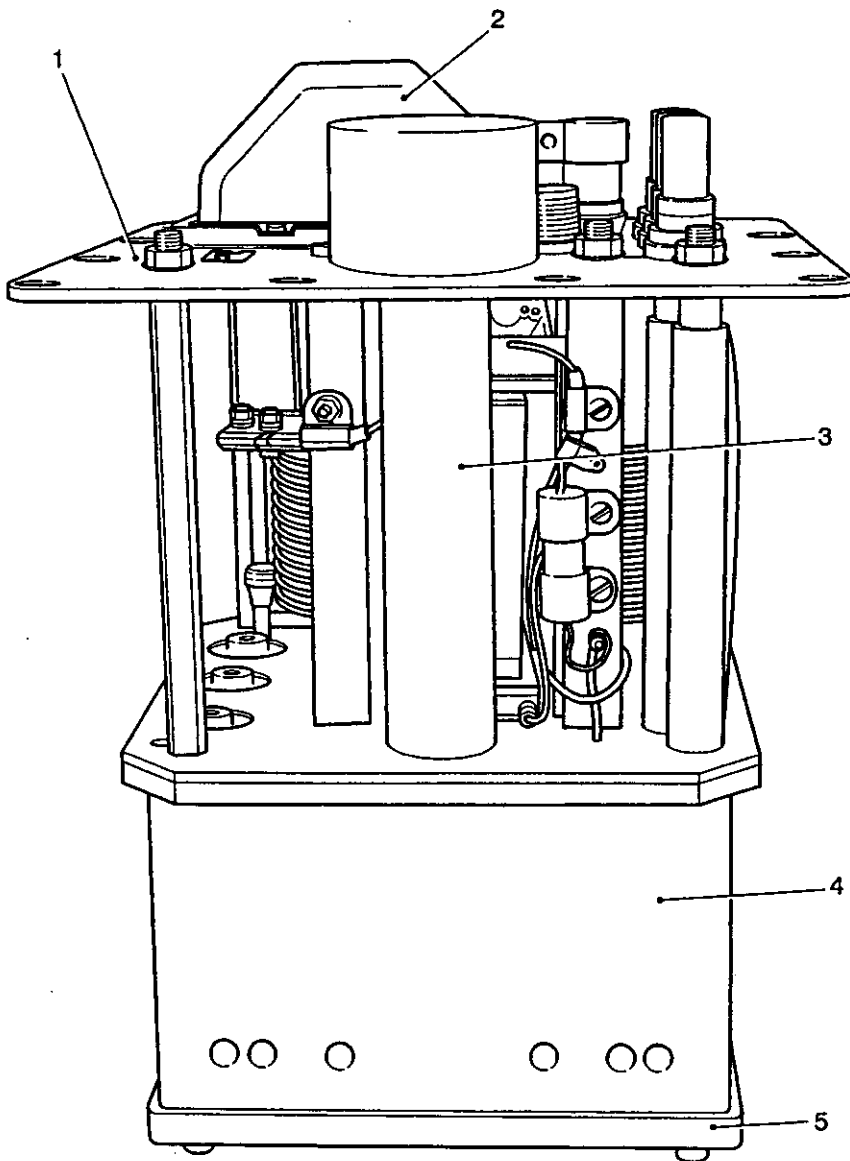

432/385

- | | | | |
|---|------------|---|-------------------------|
| 1 | Top panel | 4 | Lower compartment cover |
| 2 | Fuse cover | 5 | Lid |
| 3 | Oil pipe | | |

Fig 16 Rectifier unit No. 1, Mk 1

Panel

81 The panel houses fuse (Fig 18(1)), a seven pin socket (4), five heavy duty plugs (2), two heavy duty sockets (5) and the oil pipe connection (3).

82 The fuse is of the link type and is protected by a cover (Fig 16(2)) and gasket secured to the panel by eight cheese head screws; the fuse lugs are bolted to terminal posts located in the panel. It is connected in the main DC positive line and is rated at 250 amps.

83 Connections to the unit are made to the heavy duty plugs identified AC 1, AC 2, AC 3 (ac input from alternators) and dc positive (main dc supply), the sockets identified dc negative (main dc negative) and to the seven pin socket. Pin A of the socket is an auxiliary dc positive supply to energize the generator only relay, Pin B is a dc negative, Pins C and D are ammeter connections from the ammeter shunt, Pin E is a dc positive supply not protected by the rectifiers unit main fuse and Pins G and F are not connected. Pins A, C, D and E only are used in this installation.

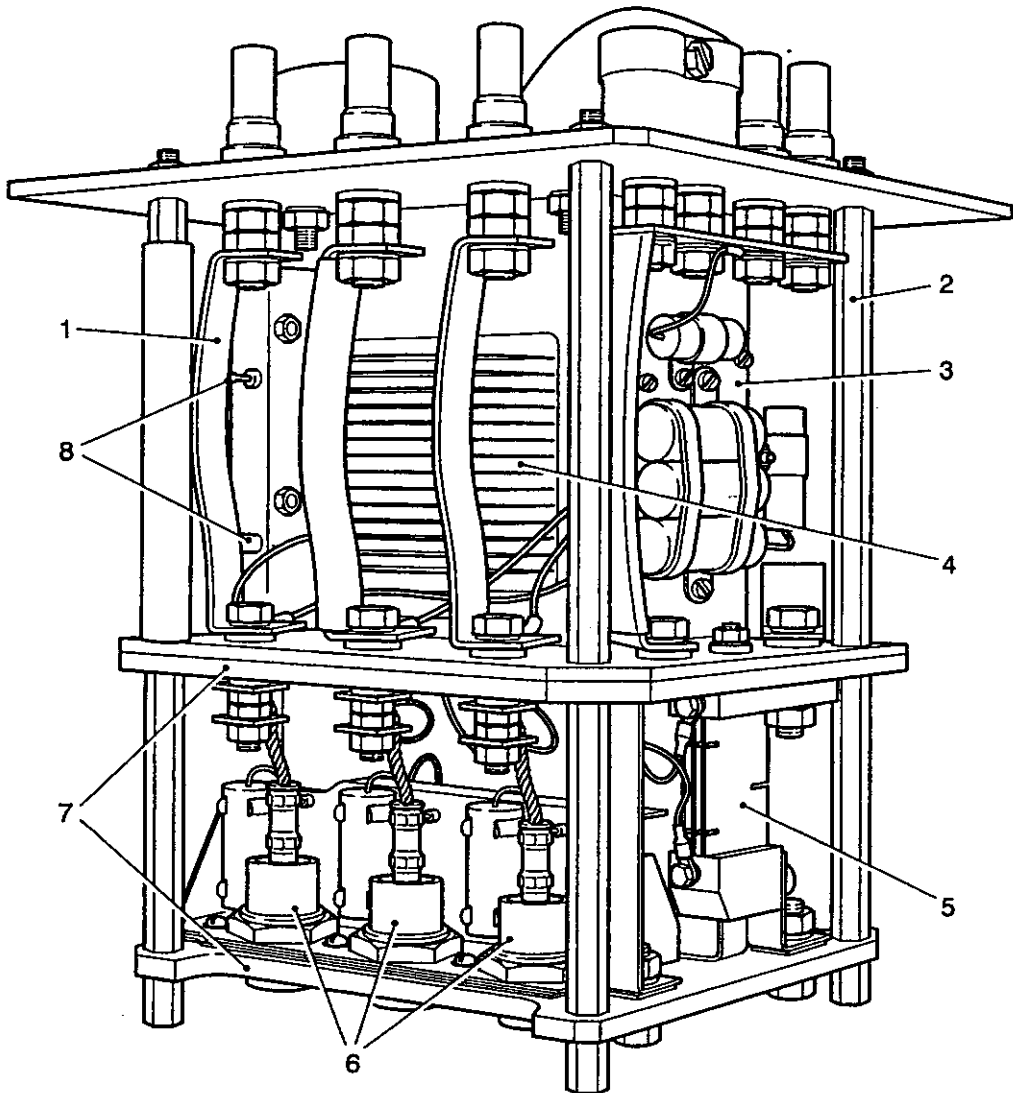

432/384

- | | | | |
|---|------------------|---|------------------------------------|
| 1 | Copper strip | 5 | Ammeter shunt |
| 2 | Hexagonal pillar | 6 | Diodes |
| 3 | Insulating panel | 7 | Upper and lower compartment plates |
| 4 | Choke | 8 | Soldering pins |

Fig 17 Rectifier unit - lower cover removed

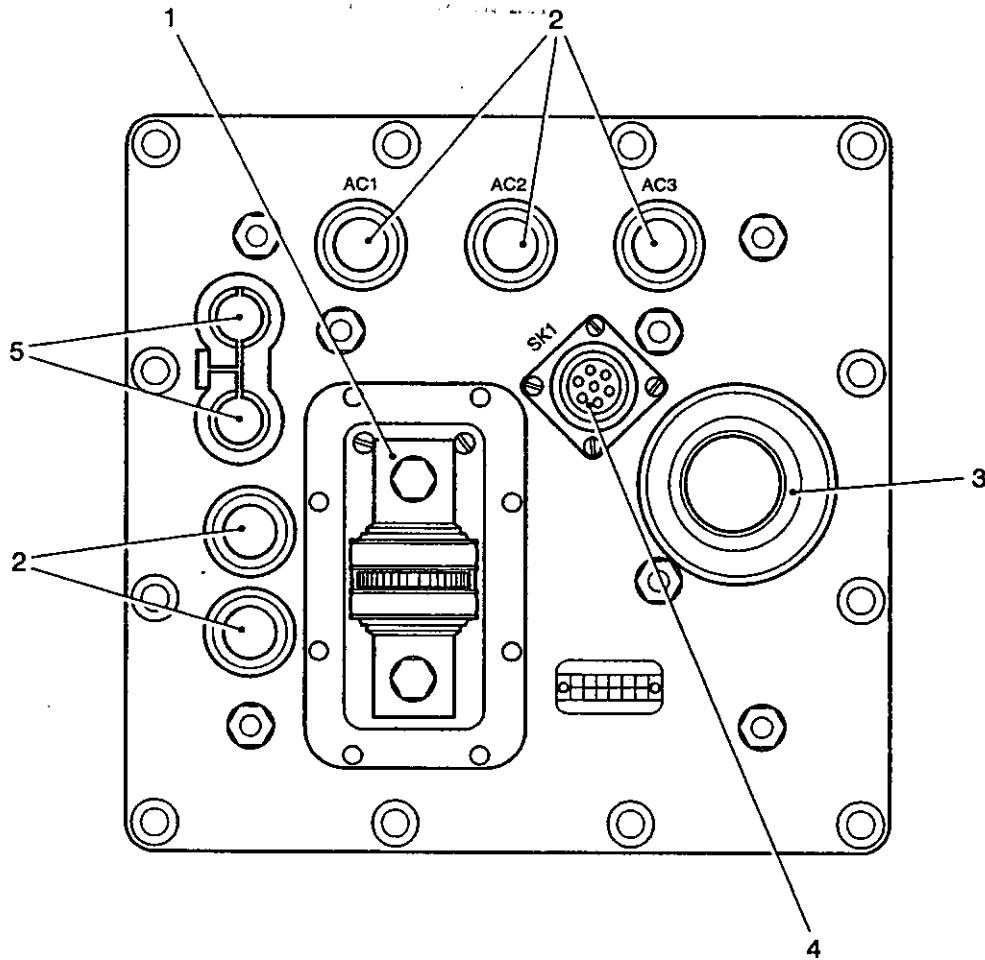

432/383

- | | |
|--|--|
| <p>1 Fuse
2 Heavy duty plugs
3 Oil pipe connection</p> | <p>4 7-pin socket
5 Heavy duty sockets</p> |
|--|--|

Fig 18 Rectifier unit - top panel

Upper compartment

84 The upper compartment houses a choke (Fig 17(4)), an insulating panel (3) with five capacitors and one capacitor mounted on soldering pins (8) on the choke frame (Fig 19(2))

85 The choke consists of a silicon steel strip core (4) (C core) clamped between frames and edge wound with two copper strips parallel, each turn being separated by insulating discs (1). The strips are each drilled to take screws and nuts for connection to one connecting strip from the main fuse and one strip from the ammeter shunt in the lower compartment. The choke is connected in series with the main dc positive supply and is provided to smooth any ac ripple.

86 The capacitor panel (Fig 17(3)) is located on the choke frame and the tubular capacitors are retained in position by clips, in one group of three and two single capacitors. The capacitor group is coupled between each ac input and earth, one single capacitor dc negative and earth and the other between Pin D of the 7-pin socket and earth. The capacitor on the choke frame is connected between Pin A of the socket and earth.

87 Copper laminated strips (1) connect the heavy duty plugs and sockets on the panel, to components located in the lower compartment, via through terminals located in the insulating plate forming the base of the upper compartment.

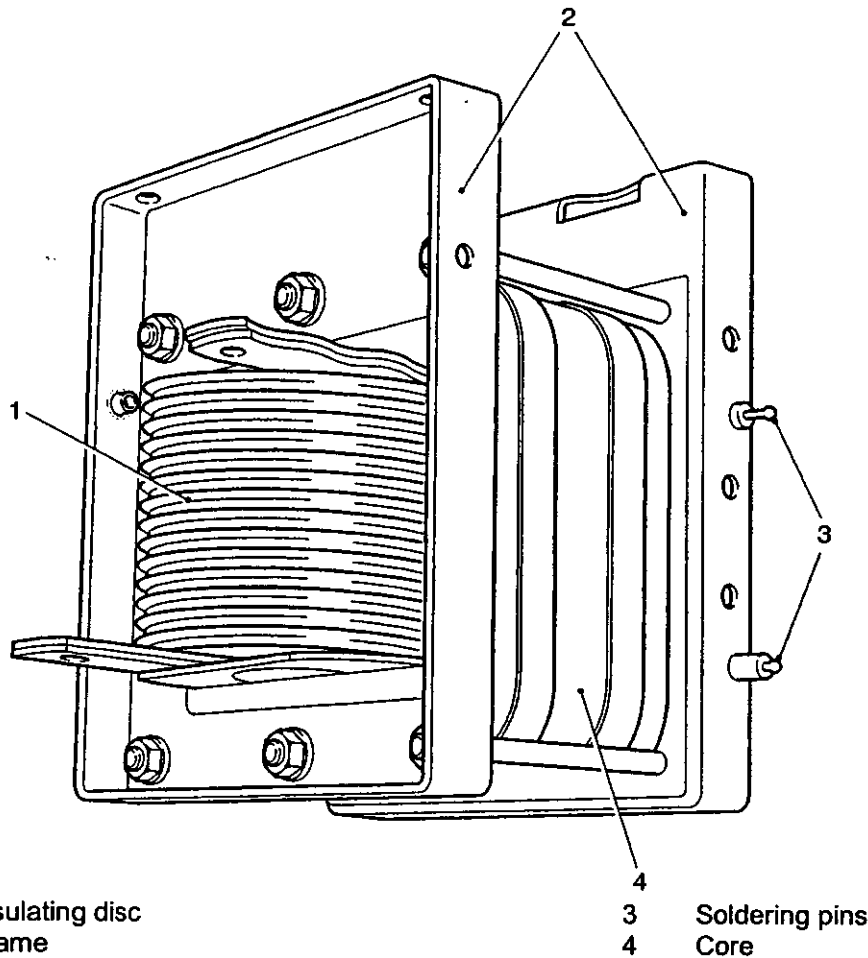

432/394

- | | | | |
|---|-----------------|---|----------------|
| 1 | Insulating disc | 4 | Core |
| 2 | Frame | 3 | Soldering pins |

Fig 19 Rectifier unit - choke

Lower compartment

88 The lower compartment (Fig 20) houses six main and three auxiliary diodes (2), radio interference suppression capacitors (3) and an ammeter shunt (5).

89 The main diodes (4) of the silicon semi-conductor type are of the tubular metal case construction, each provided with a securing nut and washer at one end and a flexible connector at the other. The diodes are arranged in a 3-phase bridge circuit and are located in two heat sinks each housing three diodes.

90 The heat sinks (6) are constructed of aluminium alloy and serve to conduct heat from the main diodes to the cooling oil. Each diode locates in a hole in the heat sink and a bus bar is located between the three diodes and the sink, to serve as a common connector point; one sink serves as the main dc positive and the other the main dc negative. Due to this common connection to either dc positive or negative, one set of three diodes is polarized anode to flexible connector and the other set cathode to connector, those in the dc positive line are cathode to connector and in the dc negative line, anode to connector. This polarity change is indicated on the diode body by a diagram and in the case of diodes polarized anode to connector, the letter R is included in the type number. The flexible connections (7) are connected to three copper bus bars located on the underside of the upper compartment base. The vertical side of each sink carries three spring clips, each housing a radio interference suppression capacitor; the sink with bus bar and diodes, is secured to the lower compartment insulating base by the diode securing nuts.

91 The auxiliary diodes are located, together with three of the interference suppression capacitors housed in clips, on a panel spanning the vertical sides of the heat sinks. The diodes are similar to the main diodes except that the current rating is lower, resulting in smaller physical size. They are arranged in a 3-phase full wave circuit.

92 Located at one end of the heat sinks is the ammeter shunt (5). It is connected at the upper end via a through terminal, to one side of the smoothing choke in the upper compartment and at the lower end to the heat sink serving as the common dc positive.

99 The six interference suppression capacitors, located in clips on the vertical sides of the heat sinks, are connected one in parallel with each main diode, the three capacitors on the heat sink panel are connected one in parallel with each auxiliary diode.

94 The lower compartment is enclosed by a cover (Fig 16(4)) and lid (5) secured by four screws inserted in the ends of the hexagonal spacing pillars. Holes in the cover permit circulation of oil through the compartment.

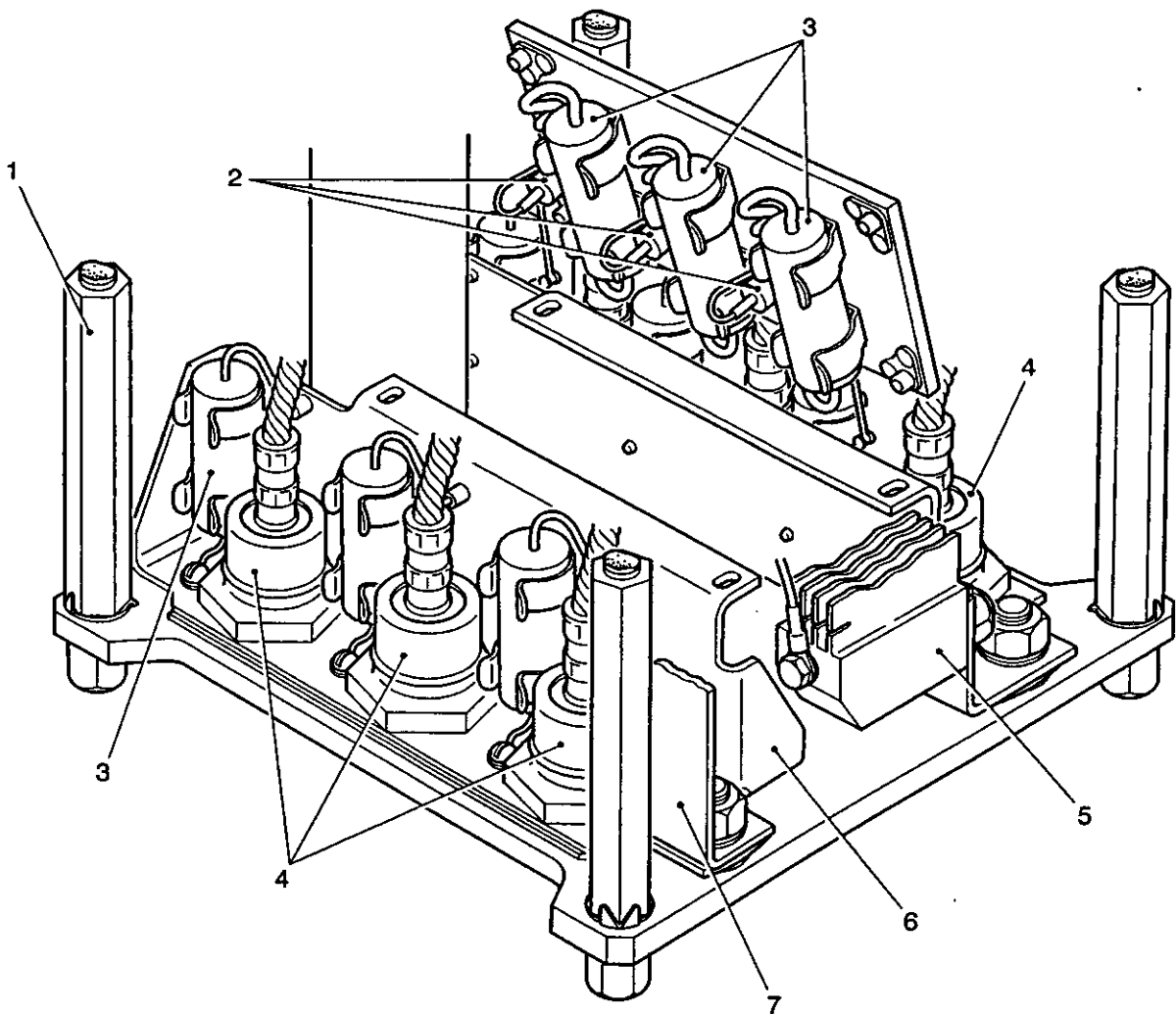

432/333

- | | | | | | |
|---|------------------------|---|---------------|---|---------------------------------------|
| 1 | Hexagon pillar | 4 | Main diodes | 7 | Copper strip
(flexible connection) |
| 2 | Auxiliary diodes | 5 | Ammeter shunt | | |
| 3 | Suppression capacitors | 6 | Heat sinks | | |

Fig 20 Rectifier unit - heat sink assembly

Operation of generating system

95 With the battery and engine switches ON, a supply is obtained from the automotive batteries via circuit breakers K and M in the distribution panel Mk 6, and the closed contacts of the alternator only load relay (No. 1) RLA4 and RLA6 (de-energized) in the distribution panel, to energize the alternator fields. The alternator warning light at the driver's switchboard is energized through RLA2, the alternator warning light at the radio distribution box No. 3, Mk 1 is illuminated when RLA is energized.

96 As the engine is started the alternator builds up quickly due to the dc excitation from the vehicle supply to produce a 3-phase output which is connected to the main rectifier diodes and when the engine speed is such that the rectified voltage exceeds the battery voltage, a forward current flows which is indicated by the ammeter in the driver's instrument panel. The output of the alternators is controlled by the regulators as described in Para 71.

97 The ac supply is also connected to the auxiliary diodes and the rectified output ('alt only' line) energizes the alternators only relay (RLA). When the voltage reaches 18.5V RLA4 and RLA6 contacts open, thus breaking the dc supply to the alternator fields; the field supply is now from the regulator, the GEN warning light circuit is broken by RLA2 contacts, thus indicating that the alternators are on line.

98 A closed pair of contacts energizes two relays for the boiling vessel sockets. The appropriate relay closes when the circuit is completed by the insertion of a boiling vessel plug into one of the sockets located on the Accessories Control Box (early vehicles) and Distribution Panel (later vehicles).

RADIO BATTERY CHARGING

99 The alternator only line energizes the alternator only relay (No. 2) in the Distribution Link Box. This relay operates at 6-8 volts through a series resistance in the coil circuit from the 24V supply. The contacts close to energize the coil of a solenoid (Relay No.1) also located in the Distribution Link Box. The switch closes at a minimum voltage of 16V and supplies one side of the battery switch in the Radio Distribution Box. With this switch closed, the radio batteries are connected in parallel with the automotive and ventilation batteries for charging purposes and supplying radio equipment.

100 An alternator warning light, located in the Radio Distribution Box is connected to the dc negative line and via an external charge switch (in the OFF position) and a 160 ohm resistor to the dc positive line. The external switch and resistor are located in the Radio Distribution Box. The lamp glows when the radio battery switch is closed and the alternators are not on line. Upon starting the engine and the alternators are on line, a negative supply is obtained from the alternator only relay (RLA), and applied to the junction of the resistor and warning lamp. The lamp will extinguish, indicating that the radio batteries are on charge. The resistor limits the leakage current to a safe value.

101 Provision is made for charging the radio batteries from a charging set and also for charging external batteries from the vehicle generating system. These facilities are not use in this installation.

DISTRIBUTION LINK BOX NO 1 MK 1

102 The distribution link box (Fig 21) consists of a metal case, fitted with a lid, and housing two load sharing transformers (1), a control circuit panel (3), solenoid switch (2) (Relay No. 1), five bus-bars, a warning light (5) and two terminal blocks (4).

103 External connections to the box are made to plugs and sockets located on one side and end.

104 The five bus-bars are of rectangular section connected between the heavy duty plugs and sockets. They are self-supporting and provided with a clamp centrally located to prevent movement. Cable connections to the bars are made by lugs retained by screws. Three bars carry 3-phase ac supply and are connected in the AC 1, AC 2 and AC 3 phases from the generator; the fourth and fifth bars carry the main dc positive and negative supplies.

106 This distribution box can be used for normal or arctic conditions. The condition is changed by fitting a link from 12H NORMAL to 12H ARCTIC. If a new distribution box is being fitted, the position of the link must be checked; the link will either be a separate item with the box, or fitted in the ARCTIC condition. When fitting a serviceable distribution box to a vehicle it is advisable to check the position of the link for whatever the conditions are required.

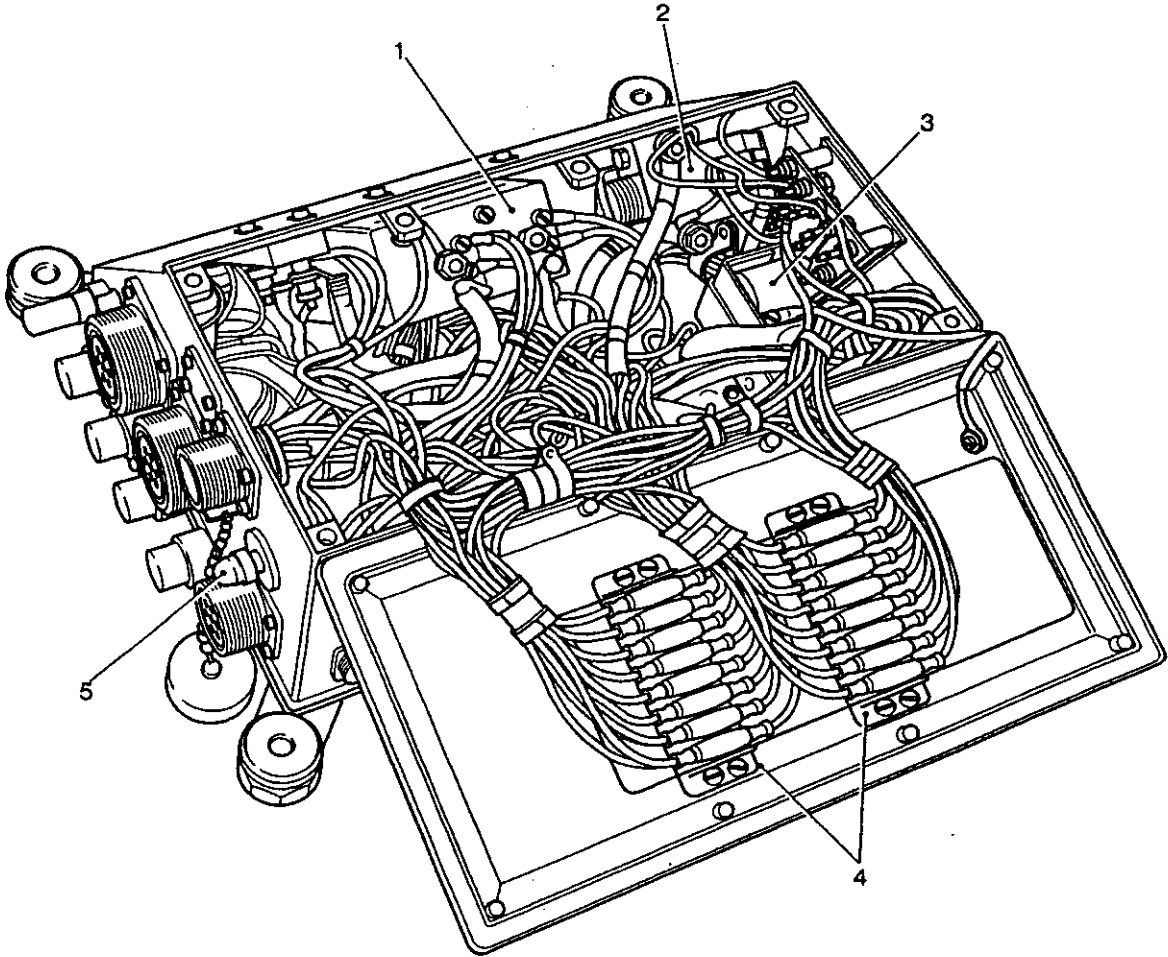

432/392

- | | | | |
|---|--------------------------|---|-----------------|
| 1 | Load sharing transformer | 4 | Terminal blocks |
| 2 | Solenoid switch | 5 | Warning light |
| 3 | Control circuit panel | | |

Fig 21 Distribution link box

LOAD SHARING TRANSFORMER

106 The transformer (Fig 22) consists of a toroidal coil housed on a bobbin, carried on a bush, with two semi-conductor diodes and a resistor located on one end of the coil. The unit is encapsulated and two terminal connections (4) are embedded in the compound (2) for external connections. The unit is secured by two screws (1) entered through two bushes in the encapsulating compound.

107 The unit is used in conjunction with a heavy duty connection pillar (3) extending through the bush and connected in series (Fig 15) with the Phase Blue (AC 3) of the appropriate alternator.

108 The toroidal coil serves as the transformer secondary winding, the primary winding being the heavy duty connection pillar axially located through the secondary coil. The alternator line current flowing through the primary sets up a magnetic flux proportional to the current flowing. The flux links the secondary winding and induces a voltage also proportional to line current. The ac voltage is rectified by the diodes and this voltage is fed via the resistor to the respective alternator control panel

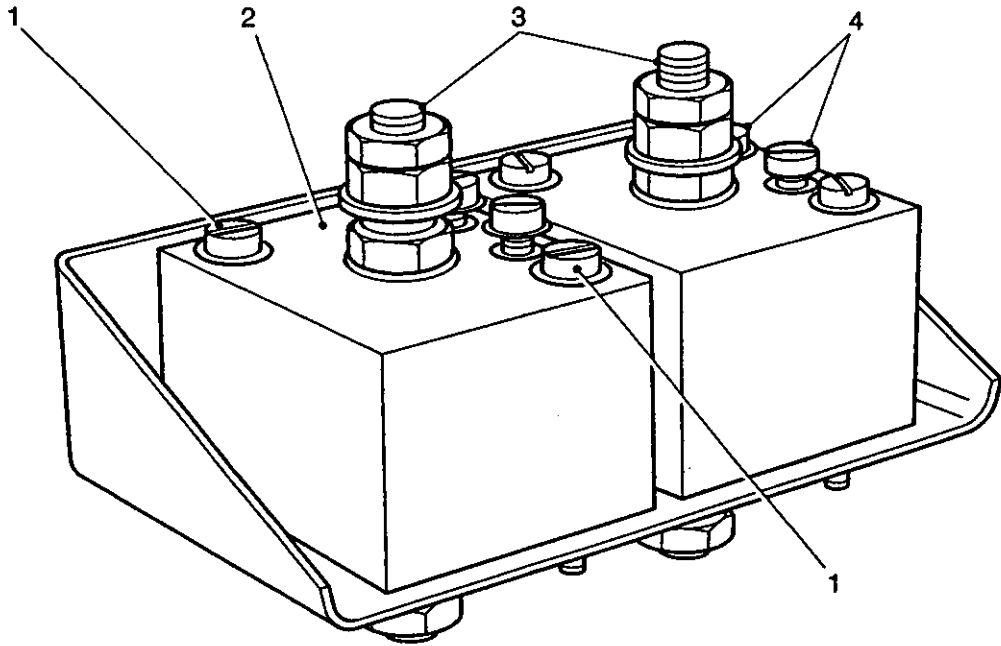

432/334

- | | | | |
|---|------------------------|---|---------------------|
| 1 | Securing screw | 3 | Connection pillar |
| 2 | Encapsulation material | 4 | Terminal connection |

Fig 22 Load sharing transformers

CONTROL CIRCUIT PANEL

109 Mounted on this panel (Fig 23) is a relay (2), resistor (3) and three semi-conductor diodes (1).

110 The relay is a single pole type with normally open contacts wired in series with the battery positive and the solenoid switch coil. The relay coil is wired in series with the 'generator only' line via the resistor and a diode to negative; the relay coil is rated for 12V operation and the resistor drops the 24V supply to 12V.

111 The diodes D1, D2 and D3 (Fig 15) are identical and of the silicon semi-conductor type providing circuit protection in the event of a reverse connection or short circuit developing on the radio batteries. The normal conditions, i.e., vehicle batteries and radio batteries connected the correct way, the resistor with warning light in parallel drops 12V of the vehicle battery supply, operates Relay No. 2, diode D2 senses the vehicle battery polarity, diode D3 is blocking since the cathode is 24V positive and the anode is 12V positive, diode D1 connected across the Relay No. 1 coil assists in the rapid collapse of the coil magnetic field. If the radio batteries are reverse connected, the resistor in series with diode 3 is across both vehicle and radio batteries a total of 48V, diode 2 is blocking since the cathode is at zero and the anode negative 24V, diode D2 prevents Relay No. 2 operating and, therefore, Relay No. 1. If the radio battery leads are short circuited, Relay coil No. 2 and diode D2 are short circuited by the forward resistance of diode D3 and is de-energized with Relay No. 2 contacts open circuit, Relay No. 1 coil is de-energized. The system will operate as for normal conditions if the radio batteries are not switched on or the batteries open circuit.

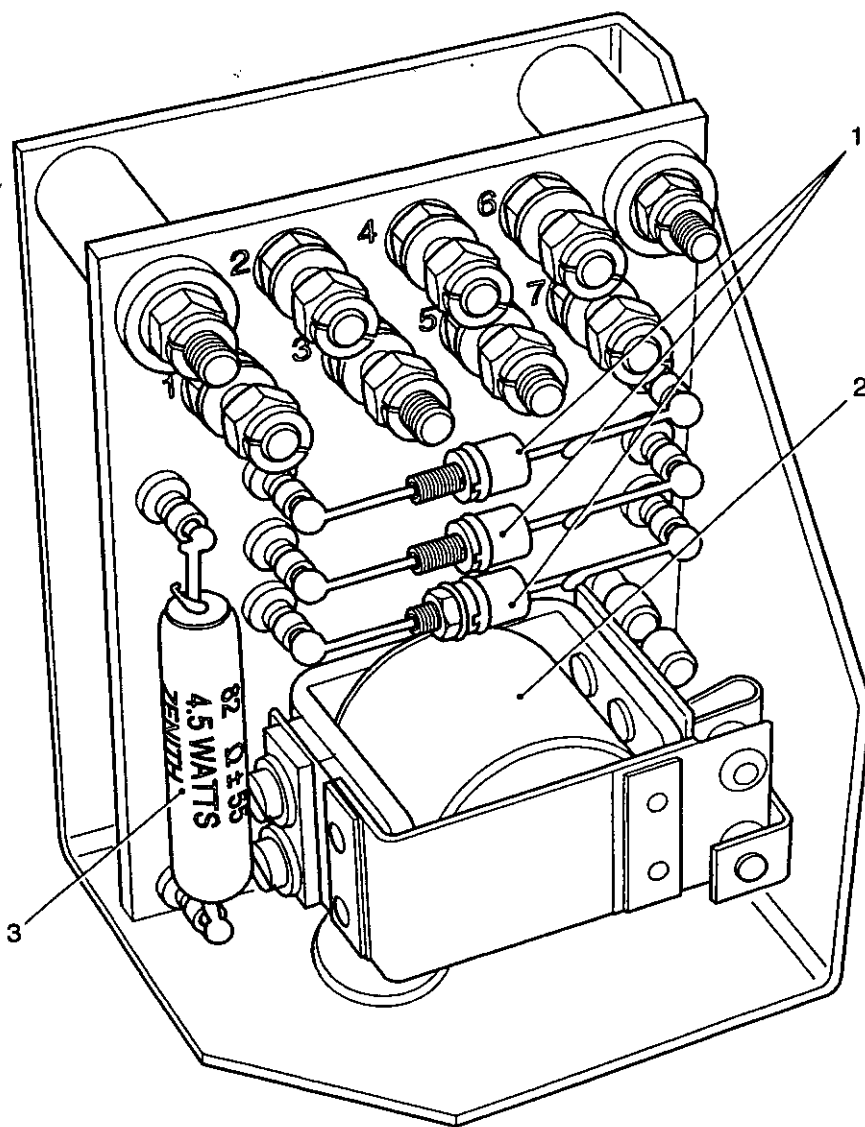

432/335

- 1 Diodes 2 Relay 3 Resistor

Fig 23 Control circuit panel

SOLENOID SWITCH

112 The solenoid switch (Fig 24) consists of a mounting stirrup (9) to which is riveted a core and base plate assembly, fitted with a coil (10) wound on a brass tube. Brass bushes fitted to the ends of the core act as bearings for the solenoid plunger (11). Plunger travel is limited by a stop embodied in the stirrup, the inner end of the core acting as a return stop. Two contact strips (8) are bolted to the base plate, they are insulated by strips and bushes.

113 The moving contact (5) is U-shaped and mounted on a flanged insulating sleeve (2) secured to the solenoid plunger stem by a spring washer (3) and nut (4). Interposed between the moving contact and the flange of the sleeve is a leaf spring (1) which loads the contact; on the other side of the moving contact are fitted thin and thick insulating washers (6) and the main spring (7). The thick washers act as a spigot and back plate for the springs; the thin washers are adjusting washers fitted to give designed clearances between the fixed and moving contacts. To prevent them turning, the insulating washers and the sleeve located on a dowel pin fitted to the outer face of the plunger which is slotted to ride a key formed in the solenoid core.

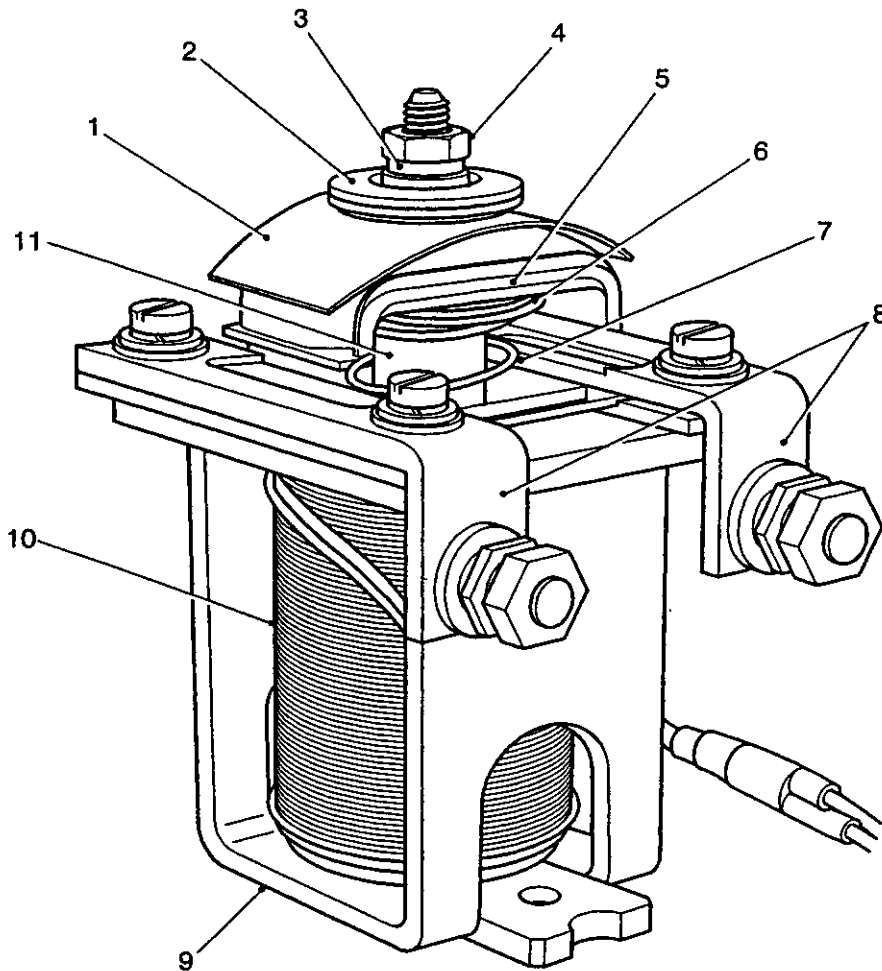

432/382

1	Leaf spring	5	Moving contact	9	Mounting stirrup
2	Sleeve	6	Insulating washer	10	Coil
3	Washer	7	Main spring	11	Solenoid plunger
4	Nut	8	Contact strip		

Fig 24 Solenoid switch

WARNING LIGHT

114 The warning light (Fig 21(5)) is of the 'press-to-test' type fitted with a red lens and housing a 28W, 0.04A miniature flanged type lamp. The light is connected in parallel with the relay coil dropping resistor and operates in conjunction with three diodes. Under normal conditions with the alternator running, 12V are applied to the 28V lamp and hence it glows at half brilliance. Should the radio battery be connected in the reverse direction, 28V are applied to the lamp and it glows at full brilliance before the engine is started; if the engine is started in these circumstances, 48V are applied and the lamp will burn out, damage to the generating equipment will also result. The operation of the diodes is such that the relay and solenoid switch are prevented from closing and the radio battery is no connected to the line.

115 Should an earth fault develop on the radio battery positive line, 24V will be applied to the light with the alternator running and as in the previous case, the relay and solenoid switch will not close. The system will operate normally if the radio battery is open circuited or not switched on.

DISTRIBUTION PANEL NO. 6, MK 1

116 The unit (Fig 25) comprises a rectangular metal case (3), fitted with four anti-vibration mountings (4) and a hinged cover (1) fitted with a sealing ring (Fig 26(1)) and secured by ten screws to the case.

117 The case houses a battery switch, solenoid switch (4), relay assembly (9), an inter-vehicle starting socket (6), inspection light socket (7) and desiccator (8). The cover houses eleven circuit breakers (Fig 25(5)), three toggle switches, the fan switch (6), the heater switch (7) and the external light switch (8), battery switch (11) and battery selector (9). The circuit breakers are protected by a hinged cover (10) and secured by a knurled nut (2).

118 Connections to the unit are made to plugs and sockets located in the case sides.

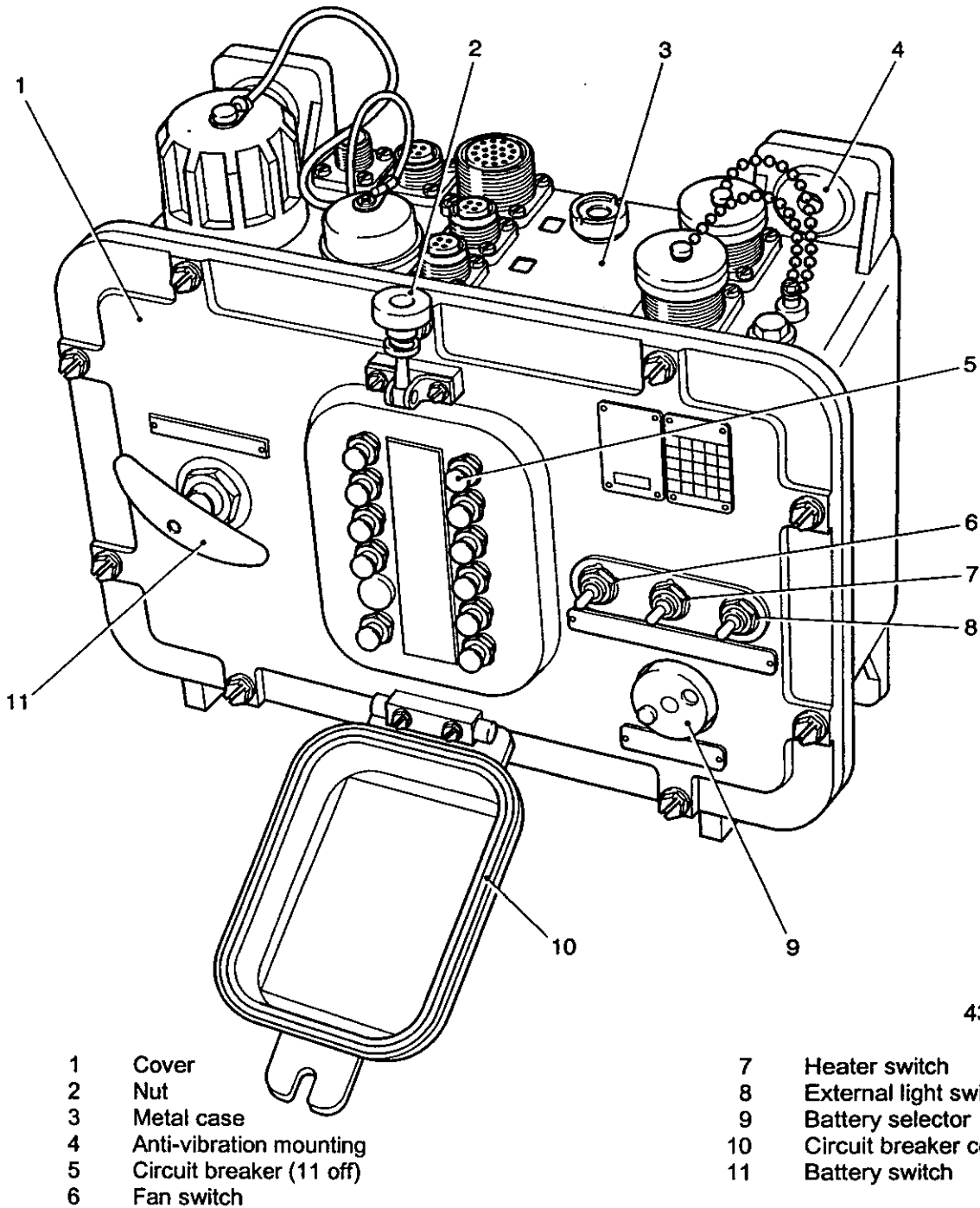

432/342

- | | | | |
|---|--------------------------|----|-----------------------|
| 1 | Cover | 7 | Heater switch |
| 2 | Nut | 8 | External light switch |
| 3 | Metal case | 9 | Battery selector |
| 4 | Anti-vibration mounting | 10 | Circuit breaker cover |
| 5 | Circuit breaker (11 off) | 11 | Battery switch |
| 6 | Fan switch | | |

Fig 25 Distribution panel No. 6, Mk 1

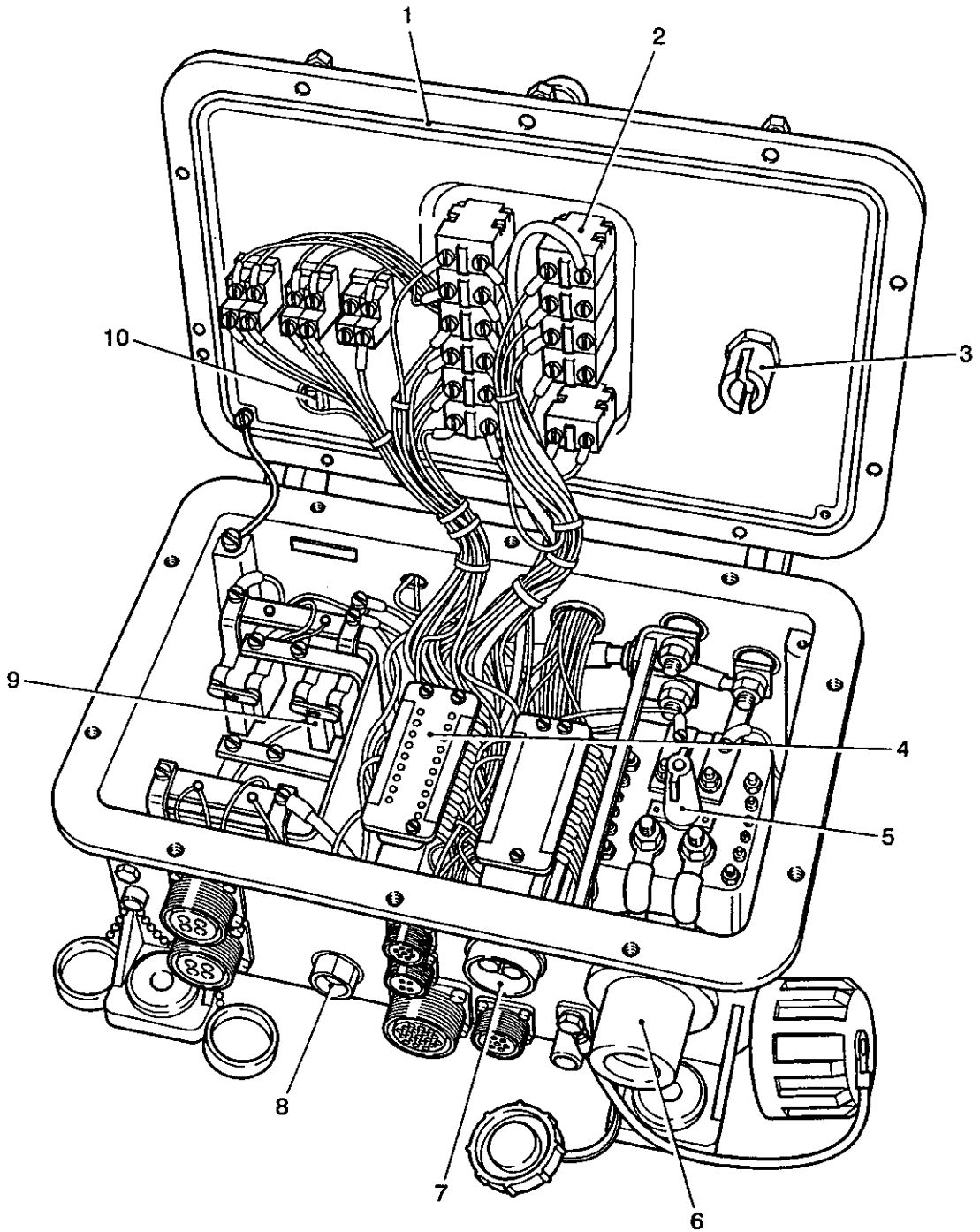

432/343

- | | | | |
|---|---------------------------------|----|-------------------------------|
| 1 | Sealing ring | 6 | Inter-vehicle starting socket |
| 2 | Circuit breakers | 7 | Inspection light socket |
| 3 | Battery switch rotatable handle | 8 | Desiccator |
| 4 | Solenoid | 9 | Relay |
| 5 | Battery switch shaft assembly | 10 | Battery selector |

Fig 26 Distribution panel No. 6, Mk 1 - cover open

Battery switch

119 The battery switch comprises a base plate (Fig 27(5)) with four main contacts, four pairs of auxiliary contacts (16) and a moving contact assembly operated by a semi-rotatable handle fitted to the cover.

120 The moving contact assembly consists of two pairs of insulating contact carriers (11) each carrying a contact shoe (8) free to rock about a central retaining pin (9). A leaf spring (10) mechanically links the carriers together, thus permitting follow through after contact is made.

121 The carriers and leaf spring are secured to a guide rod (1) and lock nut (12) and a washer; the rod is fitted at the upper end with two pins (2) and (3) and located in a shaft assembly. At the lower end the shaft assembly carries an insulating plate (13) fitted with four bridging contacts (14) and (15) arranged one on either side of the upper and one on either side of the lower plate face. The upper end of the shaft assembly is provided with a keyway.

122 The shaft assembly is housed in a switch cam (4) fitted to the base plate; a pin located in the keyway prevents rotation.

123 The upper pin of the guide rod engages in a slot in the end of the switch handle located in the panel cover.

124 When the guide rod is turned by the handle, the lower pin of the guide rod follows the contour of the switch cam to raise or lower the guide rod with shaft assembly against the pressure of a spring (17) to open or close the switch contacts.

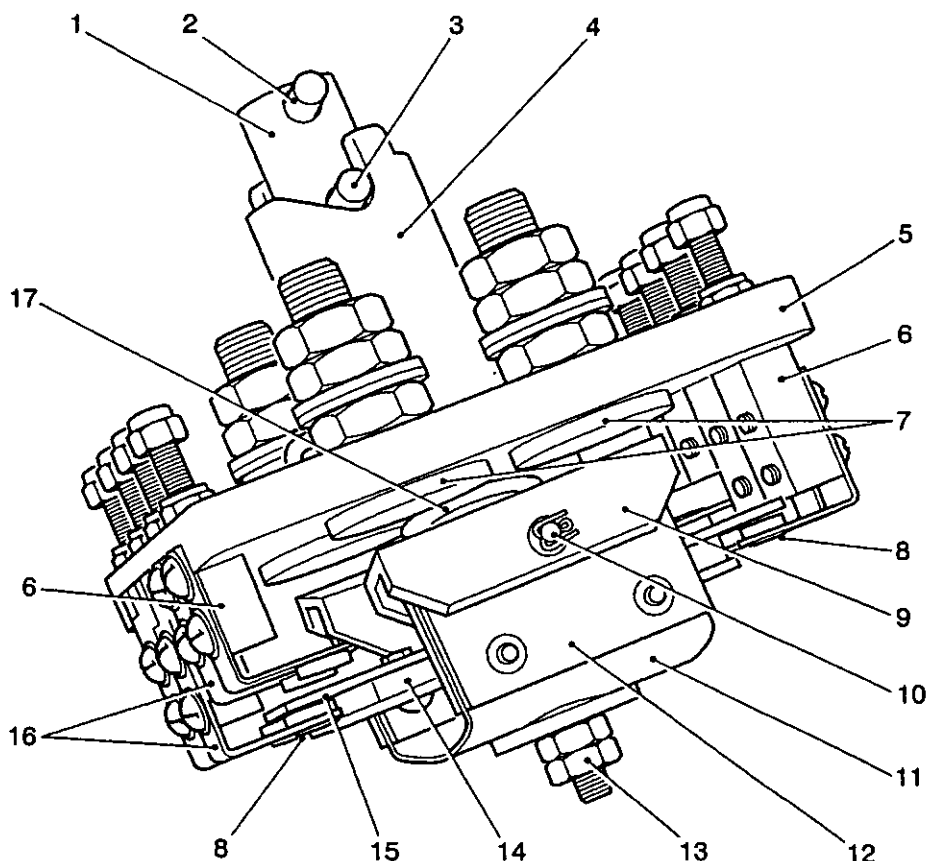

432/344

- | | | | |
|---|----------------|----|--------------------------|
| 1 | Guide rod | 10 | Leaf spring |
| 2 | Pin | 11 | Contact carrier |
| 3 | Pin | 12 | Locknuts |
| 4 | Cam | 13 | Insulating plate |
| 5 | Base plate | 14 | Bridging contact (upper) |
| 6 | Contact pillar | 15 | Bridging contact (lower) |
| 7 | Contact studs | 16 | Auxiliary contacts |
| 8 | Contact shoe | 17 | Spring |
| 9 | Retaining pin | | |

Fig 27 Battery switch

125 The base plate is fitted with four contact studs (7), bridged by the contact pieces in two pairs, when the switch is in the ON position. The two pairs of contacts connect the ventilation and automotive battery positives to the vehicle main dc positive line.

126 Eight auxiliary contacts (16), carried on pillars (6) fitted with terminal connections are arranged four at each side of the base plate. The contacts are bridged in pairs by the bridge contacts on the shaft assembly and are arranged to make and break in alternate pairs, i.e., one pair is bridged on both side when the switch is ON, and the other pair when the switch is OFF. In this installation only one pair of contacts are used, they are made when the switch is ON and complete the dc supply to circuit breaker K.

Solenoid switch

127 The solenoid switch (Fig 28) comprises a moulded base (3) provided with a sealing ring (Fig 30(1)), cover (Fig 28(2)), a contact assembly, and a solenoid assembly.

128 Housed in the base (Fig 29) is the four pole changeover contact assembly and terminal connections (12). Each fixed contact (3) is integral with the moulded base; sixteen contacts are arranged in eight pairs, four on each side of the base and bridged by four main contact bars. Each main contact bar (4) bridges one contact of the two sets at opposite sides of the base and is mounted on a forked spring (5) to an operating arm (13) located in the base well.

129 The operating arm consists of eight square insulating blocks arranged in two sets of four and separated by a counterbalance weight (11). The weight is provided to counterbalance the weight of the solenoid plunger if the relay is subjected to shock. The four forked springs carrying the contact bars are inter-spaced between the insulating blocks. The blocks, weight and springs are clamped together by two bolts and secured at one end to a cranked arm (2) fitted with a bearing pin, free to slide in a bearing block secured to the base. An adjusting screw (1) and nut carried on a cranked arm is attached to one end of a tension spring (14) protected by a clear plastic tube (10). The other end of the operating arm is pivoted to the lower end of a centrally pivoted vertical arm (8). The other end of the spring is also attached to an adjusting screw and nut, carried on a bracket (6) secured to two vertical supports (7) on the relay base. Each contact bar has a U shaped clearance to allow a passage for the spring.

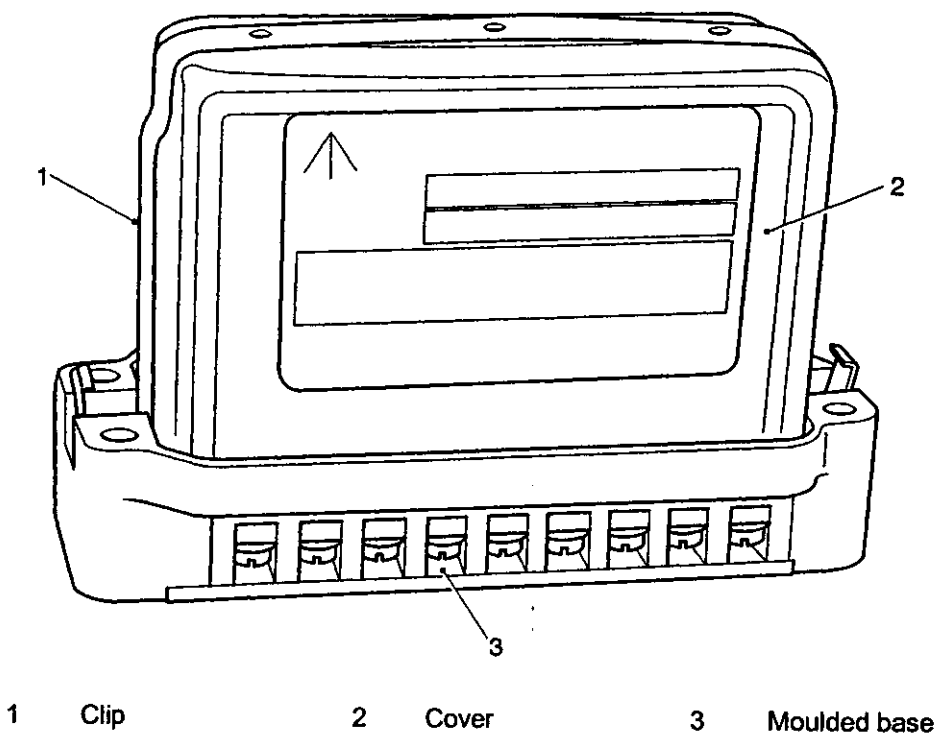

432/381

1 Clip 2 Cover 3 Moulded base

Fig 28 Solenoid switch

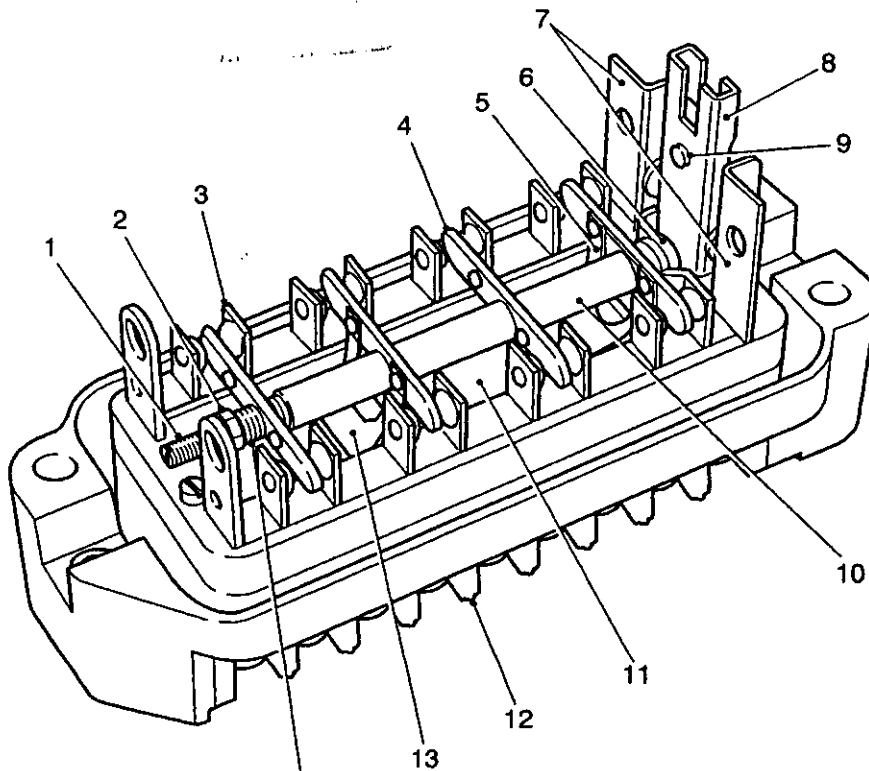

432/380

- | | | | |
|---|------------------|----|-----------------------|
| 1 | Adjusting screw | 14 | Tension spring |
| 2 | Cranked arm | | |
| 3 | Fixed contact | | |
| 4 | Contact bar | | |
| 5 | Forked spring | | |
| 6 | Bracket | | |
| 7 | Vertical support | | |
| | | 8 | Pivoted arm |
| | | 9 | Adjustable stop |
| | | 10 | PVC sleeve |
| | | 11 | Counterbalance weight |
| | | 12 | Terminal |
| | | 13 | Operating arm |

Fig 29 Solenoid switch - base assembly

130 The centrally pivoted arm (8) is located between the vertical supports and at its upper end is provided with a slot to locate one end of the solenoid plunger rod. An adjustable stop (9) is provided to limit the arm travel.

131 The solenoid assembly (Fig 30) is located over the contacts and is secured at one end to the vertical supports. Two additional supports secure the other end; these supports also serve as terminal connections for the solenoid coil, an insulating bush (6) being located between each support and the solenoid assembly and a terminal screw inserted in each vertical support. The assembly consists of a coil carried on a tube and housed in a metal case (4). In one end of the tube bore is housed a soft iron core integral with one end plate (5). The other end of the bore houses the solenoid plunger fitted with two PTFE rings (2) to enable it to move freely in the bore. The plunger is centrally located in the end plate (3), which is secured via the insulating bushes to the vertical supports and case; connections to the coil are brought through insulating bushes in the end plate and are secured to the terminals on the vertical supports.

132 An axially located rod, secured to the plunger by a ring nut, extends through the core to engage the upper end of the pivot arm by means of a transverse pin engaging in the pivot arm slot.

133 When the coil is energized, the solenoid plunger moves inwards towards the solenoid core and the rod moves the upper end of the pivoted arm outwards, the lower end moving inwards about the pivot. The operating arm is moved forward against the tension of the spring to operate the moving contact bars. The coil is energized from the alternator only line when the alternators are on line.

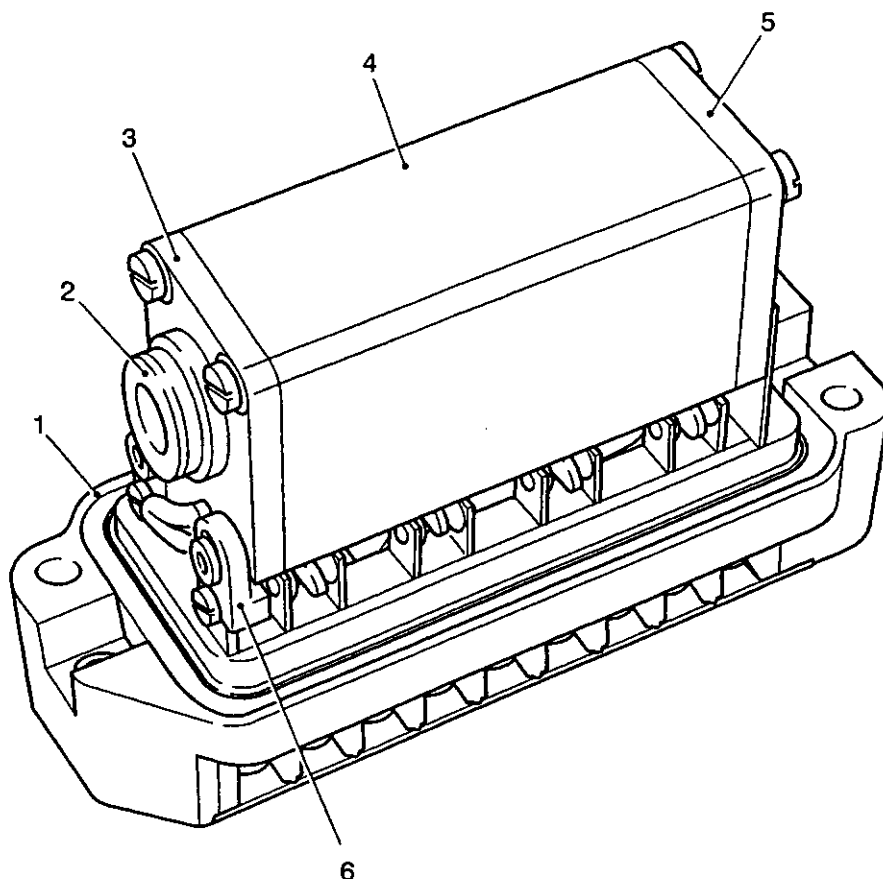

432/379

1	Sealing ring	4	Metal case
2	PTFE rings	5	End plate
3	End plate	6	Insulating bush

Fig 30 Solenoid switch - cover removed

Relay assembly

134 The four relays and three silicon diodes comprising the relay assembly (Fig 31(8)) are mounted on a U-bracket (5) secured to the panel case by four studs entered through U-clips (7) at each side of the bracket.

135 Angle brackets (2) and (6) are provided for mounting the terminal connections from the relay coils. The terminals are identified RB, 12C, 13C, and 14C.

136 Each relay (8) is a single pole type with two fixed heavy duty contacts secured to the relay base and bridged by a moving contact when the relay coil is energized. The moving contact is a flat plate pivoted on a flat spring fitted to an armature centrally located over the relay coil.

137 Connections to the heavy duty contacts are made to lugs (1) and busbar (4) located above the U-bracket; connections to the coil by two terminals located at the lower end of the relay base. One connection from each relay coil is brought to a terminal located on the angle bracket.

138 Two relays control the two boiling vessel sockets, one relay the ventilation heater and one the battery selector circuit.

139 The three silicon diodes are self supporting and are located, one (3) between terminals RB and 12C and two below the busbar connecting lugs adjacent to terminals 13C and 14C. Each diode has a cylindrical metal body with wire ends terminated in rolled cable ends. The diode body is encased in a black sleeve, the positive wire end in a red sleeve and negative wire end in a black sleeve.

140 Two of the diodes are connected in parallel with the coils of the boiling vessel relays to absorb induced voltage surges when disconnecting the boiling vessels; the third diode is connected in series with the coil of the battery selector relay to prevent the relay operating in the event of a reversed battery connection.

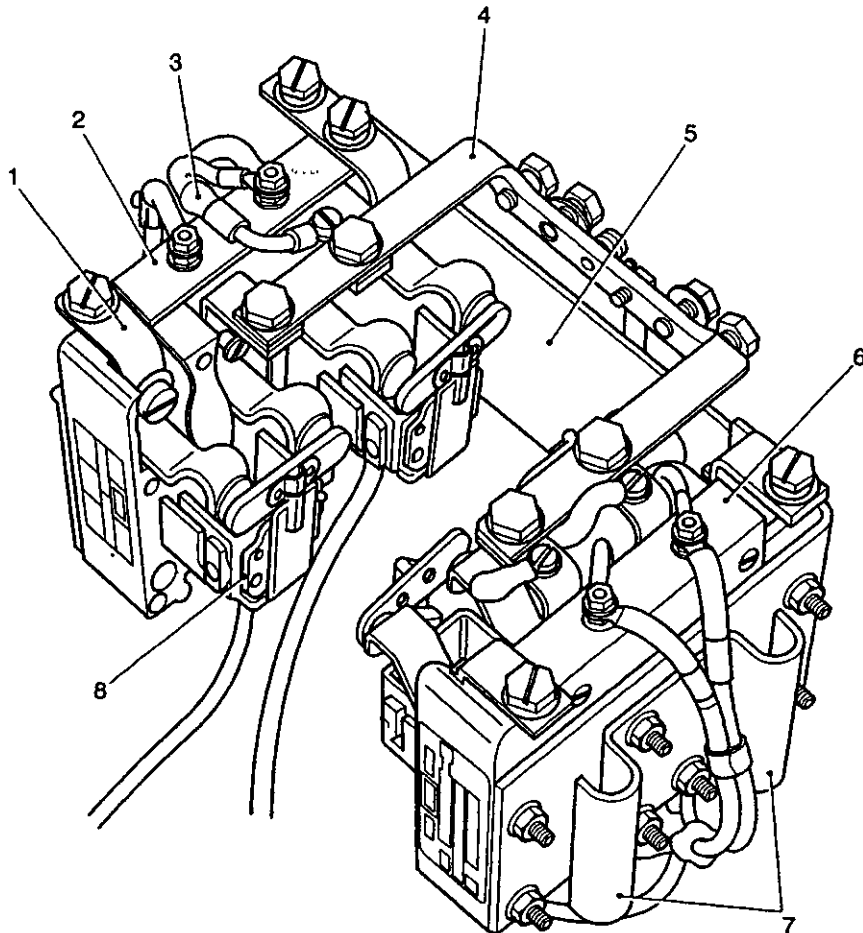

432/377

1	Lug	4	Bus bar	7	U clip
2	Angle bracket	5	U bracket	8	Relay
3	Diode	6	Angle bracket		

Fig 31 Relay assembly

Circuit breakers

141 The eleven circuit breakers (Fig 25(5)) are identical in construction, differing only in current rating.

142 Each circuit breaker is a bi-metal single pole type, having two fixed contacts, bridged by a moving contact assembly incorporating a bi-metal strip. Incorporated in the unit is a spring-loaded actuating button, a self-setting thermal latch and a mechanical latch which is connected to the moving contact assembly by two tension springs and maintains the contacts in their closed working state. The button has a black face with the current rating value engraved on it; a white collar on the stem of the button shows only when the circuit breaker is in the tripped position.

143 When the button is pressed, the contacts are closed via the bi-metal assembly. At the end of the travel, the mechanical latch engages and holds the contacts closed. When excessive current flows, the thermal latch is tripped, allowing the moving contacts to return to the open position by the tension springs and, at the same time, the mechanical latch is released and is inoperative until the thermal latch has cooled and reset.

144 To manually open circuit breaker, the button is pulled until the mechanical latch pressure is overcome.

Battery selector switch

145 The battery selector (Fig 25(11)) and (Fig 26(10)) comprises a cap and spindle assembly to operate a micro-switch located under the front cover. The spindle is provided with a flat to serve as a cam to operate the plunger of the switch. Two positions, designated 2 and 3, are selected by rotation of the cap and the respective positions are viewed through an aperture in the cap. The cap is locked by a captive screw.

146 Two contacts of the micro-switch are used and connected between relay coil RB and contact 1a on alternator only relay RLA.

147 In position 3, the relay coil RB is energized when the alternators are on line, RB relay closes and the ventilation batteries are parallel with the automotive batteries for charging.

148 In position 2, the micro-switch contacts are broken and relay RB is not energized.

RADIO DISTRIBUTION BOX NO. 1 MK 3

149 The unit is fitted on the O/S front sill below the fan pressurizing unit, it is mounted on four resilient mountings and consists of a prefabricated metal box and waterproof cover.

150 The box houses a battery switch (Fig 32(3)), a heavy duty relay (5), a four way terminal board (2), cables and busbar. Fitted to the outside are a fuse box (10), a terminal cover assembly (1), a jumper cable (11) and multiple plugs/sockets and heavy duty plugs, all identified to facilitate recognition.

151 The four way terminal board is a connection point between the box and cover.

152 The fuse box houses a link type 100A fuse, the box cover is secured by two captive knurled headed screws. The fuse connects the supply from the battery switch to the radio junction boxes.

153 The jumper cable is supplied with heavy duty sockets fitted with rubber sheaths and clamping screws. It is connected to plugs identified DUMMY and EXT GEN. The jumper cable is provided for connection to an external generator and is not used in this installation.

Battery switch

154 The battery switch is mounted on a base adjacent to the heavy duty relay. Two pairs of contact studs are bridged by two moving contacts, one contact stud of each pair is busbar connected to heavy duty plug No 1, automotive battery positive, one contact stud is connected to plugs No 7 and 8, the other stud to the 100A fuse. The auxiliary contacts are not used.

Relay

155 The heavy duty relay is a single pole type with two fixed contacts bridged when the coil is energized, one fixed contact is connected to automotive battery positive, the other contact to pin A, plug No 6. The relay and plug are not used in this installation.

Terminal cover assembly

156 The terminal cover assembly is spring-loaded and is identified LIFT AND TURN REPLACE AFTER CONNECTING. Two corners are shaped to facilitate gripping and lifting. The terminal has two hexagon lock nuts provided for connection. Inside the box, the terminal is connected by a cable link to terminal identified EXT GEN.

157 The waterproof cover contains a diode and resistor assembly (Fig 32(7)) generator warning light (Gen W/L) (9), a single pole double throw (SPDT) switch (8) and the operating handle for the battery switch (6), also fitted are two braided nylon cords with eyelets to allow the cover to be hinged for access to the wiring.

158 The diode and resistor assembly is secured to the cover by four cheese-headed screws and spring washers. The diode is connected between the SPDT switch and the relay coil and is not used in this installation. The resistor is connected to the 100A fuse and the SPDT switch, operation is described in para 100

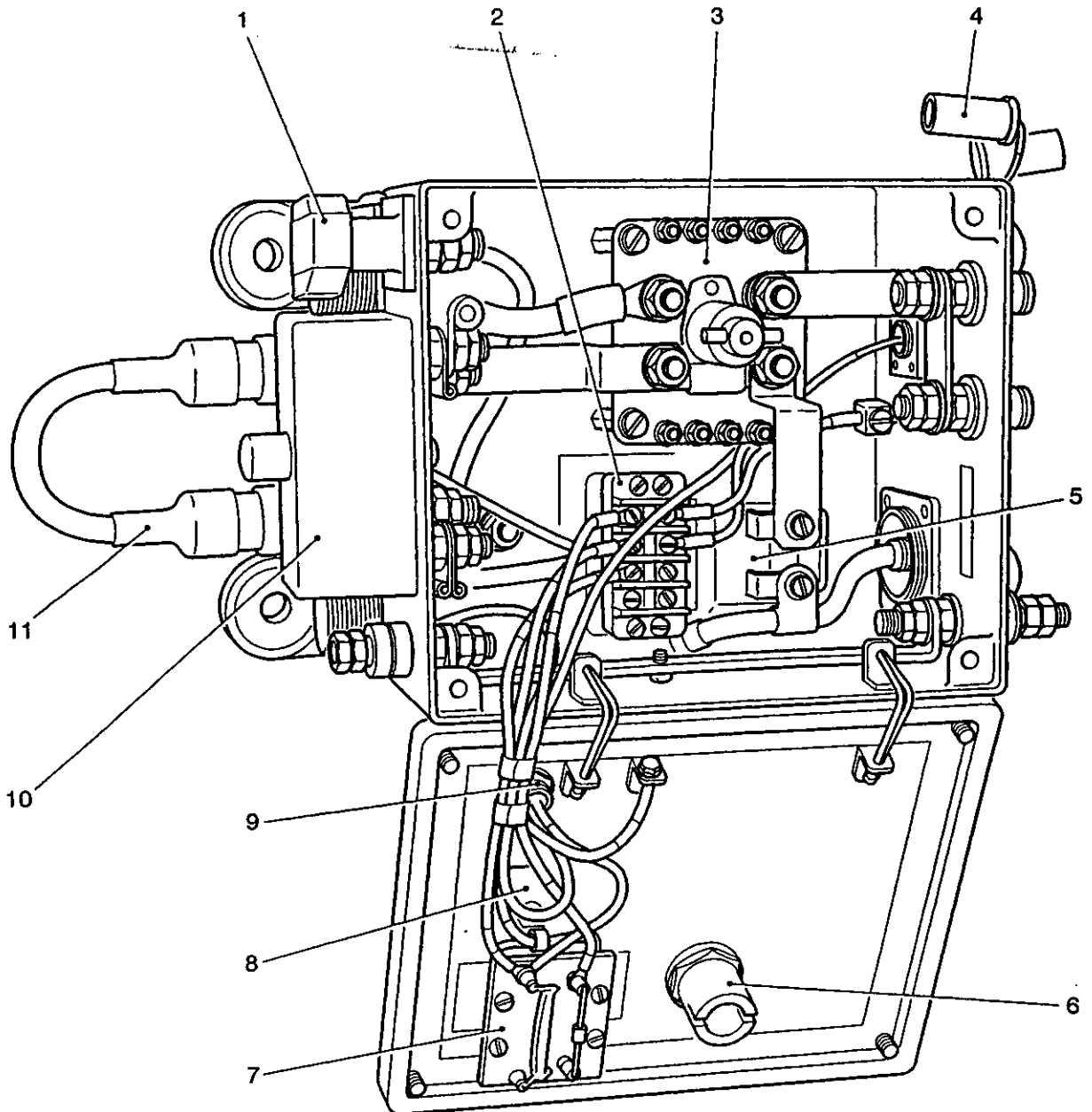

432/345

- | | | | |
|---|------------------|----|-------------------|
| 1 | Terminal cover | 7 | Resistor assembly |
| 2 | Terminal board | 8 | Switch |
| 3 | Battery switch | 9 | Generator W/L |
| 4 | Neoprene shroud | 10 | Fuse box |
| 5 | Relay | 11 | Jumper cable |
| 6 | Operating handle | | |

Fig 32 Radio distribution box No. 1, Mk 3

159 The SPDT switch is identified EXT CHARGE and in the OFF position connects a positive supply via the resistor to the Gen W/L and pin B, No 1 plug. In the N position it breaks the positive supply and connects the diode to the Gen W/L and pin B, No 9 plug. For this installation, the switch should be in the OFF position.

160 The Gen W/L is a miniature, sealed lampholder having a red screw type lens and a flanged push midget type lamp.

161 To ensure waterproofing the cover to the box, a channel inside the cover is filled with a special compound. The cover is secured by four hexagon headed screws and sealing washers.

162 Electrical connections are made via AN plugs/sockets and heavy duty plugs, heavy duty plug No 8 is provided for a command vehicle battery installation and is connected to one side of the battery switch. The neoprene shroud (4) should be fitted to plug No 8 when the vehicle is not used in the command role.

Operation

163 The operation of Radio Distribution Box is described in Para 99 to 101.

DRIVER'S CONTROL PANEL ASSEMBLY

164 The driver's control panel assembly (Fig 33) is located on the front plate of the driver's compartment, mounted on four shock absorbing bushes, secured to welded brackets by nuts, plain and spring washers. It consists of a turn light switchboard, an engine switchboard and an external lighting switchboard.

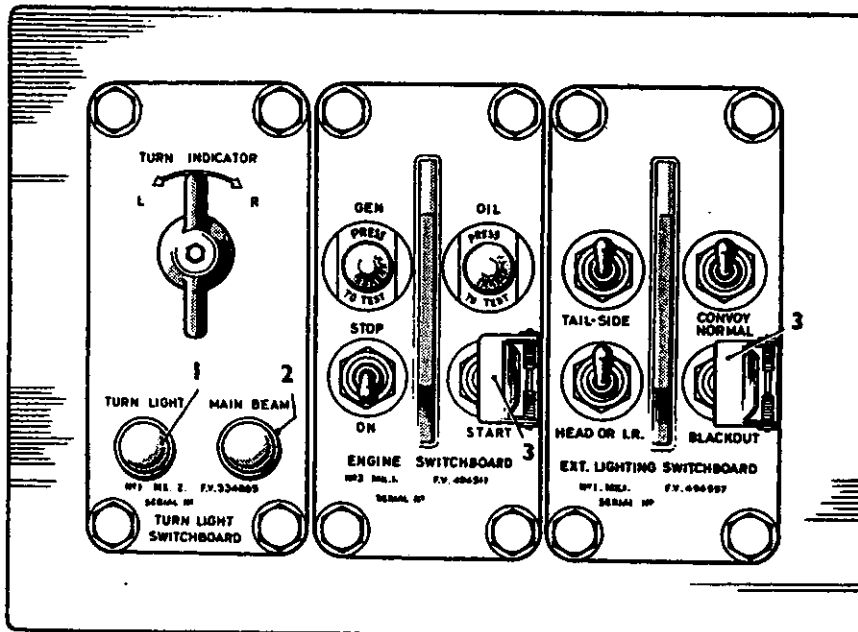

432/102

1 Turn light warning light 2 Main beam warning light 3 Switch covers

Fig 33 Driver's switchboard

Turn light switchboard No 1 Mk 2

165 The turn light switchboard (Fig 34) is a cast aluminium alloy box with a detachable rear cover. Fitted to the front face of the box is a turn light switch (1), a turn light warning light (2) and a headlight main beam warning light (3). Bolted to the inside cover of the cover is a Bosch type flasher unit (4). Connections to the box is made through an AN type plug.

Turn light switch No 2 Mk2

166 The turn light switch is a two-way rotary, three position switch, having two sections. It has a base of insulating material with a ring of numbered contacts and a hexagonal spindle with a rotor of insulating material moulded to it. Two diametrically opposite steel balls housed in spring loaded contact plates, on the underside of the rotor, locate the rotor on the base. A washer and friction nut being used to secure the spindle to the base.

167 Located on the switch spindle is a bush, swaged at its inner end, to secure a cover which encloses the switch, and which is secured by punching the cover into recesses in the base. Two nuts and a spring washer are fitted to the spindle bush for securing the switch.

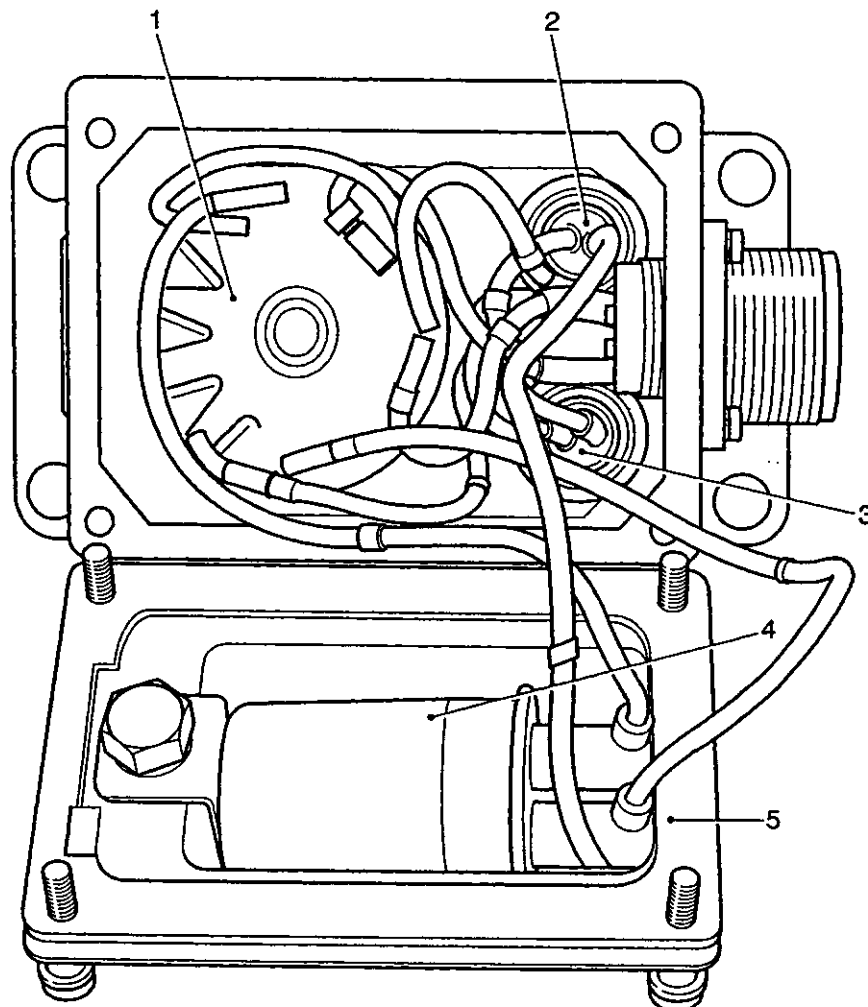

432/378

- | | | | |
|---|--------------------------|---|--------------|
| 1 | Turn light switch | 4 | Flasher unit |
| 2 | Turn light warning light | 5 | Gasket |
| 3 | Main beam warning light | | |

Fig 34 Turn light switchboard

168 A spring loaded plunger fitted towards the end of the spindle secures the switch knob. A small hole in the knob permits the plunger to be depressed and the knob withdrawn when dismantling the switch.

169 The appropriate base contacts are fitted with blade type connectors to accept LUCAR connectors. The lower section of the switch; connectors excepted; are covered in a plastic sheath to exclude dust and moisture.

170 Turning the switch to the right or the left causes one section of the switch to connect to the flasher unit and to the coil of the trailer relay, the second section completes the circuit to the appropriate turn lights through the flasher relay.

Turn light flasher unit (Bosch)

171 The turn light flasher unit comprises of a small cylindrical metal container, one end of which is rolled over an insulated plate carrying three flag connections identified 49, 49a and c.

172 The flag connections are fitted into a three circuit flag receptacle, covered by a plastic sheath to exclude dust and moisture.

173 The unit is resiliently mounted on a U shaped bracket, riveted to the bracket is a shaft that locates the top of the cover, the shaft carries a rubber bush and plain washer. The bracket is secured by two hexagon headed screws and spring washers.

174 To protect the unit, a neoprene pad is fitted inside the switchboard cover and secured by adhesive.

175 The flasher mechanism consist of two spring-loaded hinged armatures carrying main and warning lamp contacts, a hot wire resistance and a magnet winding. The armature contacts are normally open when the unit is inoperative.

Operation

176 When the turn light switch is switched on (Fig 3B refers), current flows to terminal 49 through the flasher armature, hot wire resistance and magnet winding to terminal 49a, to the flashing lamps to negative, terminal C is the supply to the warning lamp.

177 Although current is flowing through the lamps, they are not illuminated since the current is small due to the high resistance of the hot wire. The hot wire heats up and expands so that the armature is caused by force of the armature spring to move towards the core of the magnet until the flasher contacts close, this short circuits the hot wire and full current flows through the flashing lamps. The current taken by the lamp flows through the magnet winding, thereby giving an additional magnetic force to the flasher armature so the flasher contacts stay firmly closed. The resistance of the magnet winding is low, so the flashing lights illumination is almost undiminished.

178 The hot wire, being short-circuited cools and contracts so that there is an increasing pull on the flasher armature. When this exceeds the holding power of the magnet, the flasher contacts re-open. This cycle of operation is regularly repeated 70 to 90 cycles per minute until the flasher switch is switched off.

179 The main armature and the monitoring armature (warning lamp) operate concurrently i.e. when the main armature contacts open the monitoring armature is released and the warning lamp extinguished. If one of the flasher lamps fail, the current through the magnet winding is smaller and this weakened magnetic force is not sufficient to attract the monitoring armature, therefore, the warning light does not illuminate.

Turn light warning light

180 The turn light warning light (Fig 33(1)) is a miniature, sealed lampholder with an orange screw in lens and a flanged, push in midget type lamp. The light flashes in synchronism with the turn lights.

Main beam warning light

181 This light is similar to the above but has a blue lens. The light glows when the MAIN beams of the head or IR driving lights are switched on.

Engine switchboard No. 3, Mk 1

182 The engine switchboard (Fig 35) is a cast aluminium alloy box with a detachable rear cover. Fitted to the front face of the box are the generator (6) and oil pressure (5) warning lights, the engine switch (7) and the starter motor switch (4). Connections to the box is made through an AN type plug.

Generator warning light

183 The generator warning light is a press to test type light, fitted with a red screw in lens and a midget type lamp.

184 The lamp is connected across the vehicle positive and negative lines (Fig 3A refers) through the engine switch, fuse D and the normally closed contacts of the alternator only load relay in the distribution panel and, therefore, the light glows when the engine is switched on. When the generated voltage reaches 16V approximately, the relay opens and the light extinguishes.

Oil pressure warning light

185 The oil pressure warning light is similar to the above but has an amber lens. It is connected to the positive line through fuse D and the engine switch. It is also connected to the engine oil pressure switch.

186 When the engine switch is set to ON, the light glows and continues to glow until the oil pressure is sufficient to operate the oil pressure switch. It glows again if the oil pressure falls to a dangerously low oil pressure.

187 The switch is set to open at between, 0.2 bar (3 lbf in²) to 0.8 bar (12 lbf in²) and close at a decreasing pressure between 0.5 bar (7 lbf in²) to 0.2 bar (3 lbf in²).

Engine switch

188 The engine stop switch is a two pole, three position toggle type switch, having positions ON (toggle down) and STOP (toggle up) the STOP position being spring loaded to a central off position.

189 In this installation the STOP position is not used and the switch is used as an on/off switch controlling the following engine electrical functions:

- The starter switch
- The OIL and GEN warning lights
- The fuel and injection pumps
- The coolant thermometer
- The fuel gauge
- The gearbox thermometer
- The ignition
- The radio distribution box relay

190 All circuits except the last three are protected by Circuit Breaker (CB) H (or fuse D), except for the fuel and injection pumps circuit, which is protected by CB K (or fuse C).

Starter switch

191 This switch is similar to the engine switch but only has two positions – START (toggle down) and OFF (toggle up) the start position being spring loaded to off. The switch is connected to the engine switch through CB H (or fuse D) the other pole of the switch is connected to the starter motor solenoid through the gear range selector switch.

192 The gear range selector switch ensures that the gear range selector is in neutral before the engine can be started.

193 On switchboards with MOD 2 incorporated, a diode is connected across sockets G (starter solenoid connection) and B (negative connection) to absorb the back EMF induced from the solenoid when the starter is released and therefore, reducing burning of the starter motor contacts.

194 A spring loaded, hinged cover protects the switch from accidental operation.

Modifications

195 A modification plate is attached to the switchboard to show its current modification state.

External lighting switchboard

196 The external lighting switchboard is a cast aluminium alloy box with a detachable rear cover. Fitted to the front cover of the box are four two pole, two position toggle switches. The switches are interconnected to the vehicle supply through CB B (or fuse B), connection to the box is made through an AN type plug. The operation of the switches is detailed in operation of external lighting, Para 282.

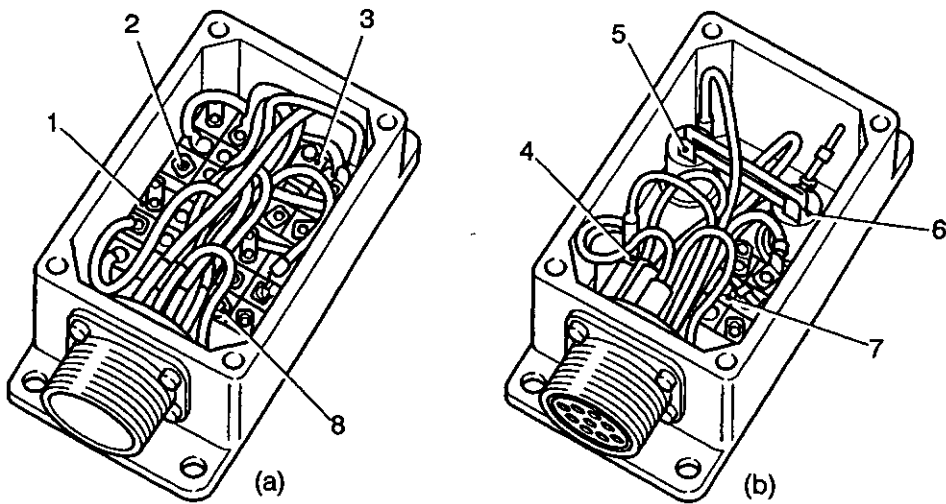

432/346

(a) External lighting switchboard
(rear cover removed)

- 1 Normal - blackout switch
- 2 Convoy light switch
- 3 Tail - side light switch
- 4 Starter motor switch

(b) Engine switchboard
(rear cover removed)

- 5 Oil pressure warning light
- 6 Generator warning light
- 7 Engine switch
- 8 Head or IR switch

Fig 35 Engine and external lighting switchboards

TWIN DIP SWITCH NO. 1, MK 2

197 The twin Dip Switch No 1, Mk 2 (Fig 36) consists of a prefabricated metal box housing a spring-loaded plunger (2), a switch mechanism (4), a waterproof cover (1) secured by four hexagon headed screws with sealing washers. Electrical connection is made via an AN plug (5) fitted to the side of the box.

198 The spring-loaded plunger is secured to the box by a hexagon nut and sealing washer. A push button is fitted to the spring-loaded plunger and is secured to a shaft by circlip; the shaft slides within a bearing sleeve against a compression spring. Integral with the shaft is a spring-loaded rod (3) to contact the switch mechanism.

Switch mechanism

199 The switch mechanism consists of an actuator assembly and three sets of change over (CO) contacts (Fig 36(8)).

200 Centrally positioned on the actuator assembly is a pivoted lever, this is in line with the spring-loaded rod. A shaft carries an actuator and two triangular shaped cams (7), which are recessed at the corners.

201 The pivoted lever turns on a boss offset from the centre, balance weights are fitted to one end, the other end engages with the actuator, to this end is fitted a spring-loaded lever.

202 The actuator has six index pins all equally spaced and is centrally located on the shaft, the cams are fitted at the ends of the shaft, one cam operates two sets of CO contacts, and the other one set.

203 The three sets of CO contacts (8) are mounted on two brackets.

204 Each set of CO contacts is identical and consist of three insulated spring arms, the centre arm is fitted with a roller (6), and the spring arm makes and breaks with the two outer arms/

205 A hexagon headed screw (10) with sealing washer fitted to the side of the box is provided for pressure testing.

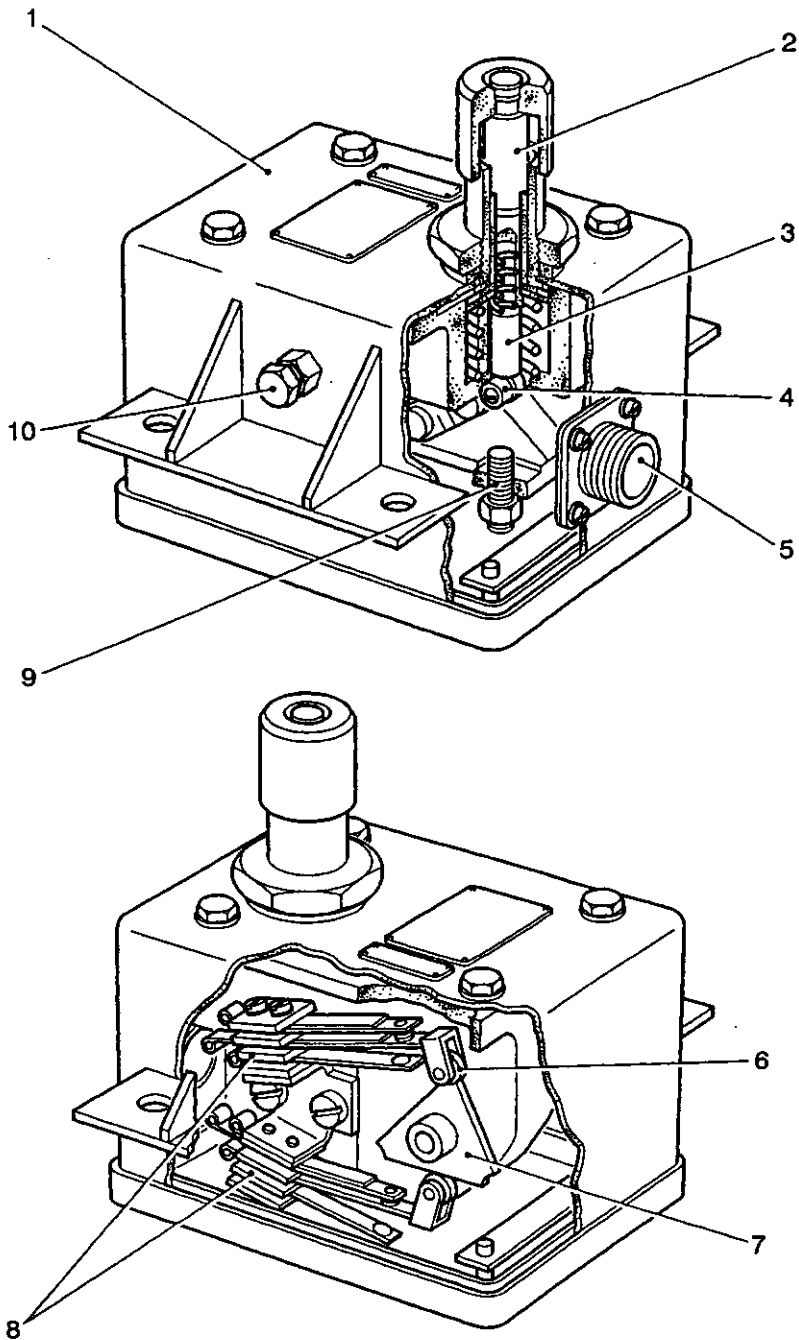

432/347

- | | | | |
|---|------------------|----|------------|
| 1 | Cover | 6 | Roller |
| 2 | Plunger | 7 | Cam |
| 3 | Rod | 8 | Contacts |
| 4 | Switch mechanism | 9 | Grub screw |
| 5 | Plug | 10 | Screw |

Fig 36 Headlight or Infra red light dipswitch

Operation

206 When the push button is depressed, the movement is transmitted to the weighted end of the pivoted lever; the pivoted lever turns on the boss causing one end of the pivoted lever to engage with an index pin and locks the actuator until the next operation.

207 The movement of the actuator moves both cams through a similar angle. The cams acting on the centre roller arm of the CO contact moves this arm in relation to the two outside arms.

208 A grub screw (9), locked by a hexagon nut accessible under the waterproof cover provides adjustment for the switch mechanism.

INSTRUMENT PANEL NO. 3, MK 1

209 The instrument panel (Fig 37) is a totally enclosed unit comprising a pre-fabricated metal box and a panel assembly; it is fitted to the off side front in the driver's compartment on two slotted brackets.

210 The pre-fabricated metal box houses two multiple plugs, one multiple socket, cable connectors and cables, welded to the outside are two brackets carrying three resilient mountings fitted with studs, plain washers and hexagon nuts. An earth braid is secured to the LH bracket.

Panel assembly

211 The panel assembly consists of a metal panel, a gasket and a transparent illuminating panel secured to the box by eight hexagon headed screws and sealing washers

212 The transparent illuminating panel is a facsimile of the metal panel, painted black, front and rear, with holes counter bored to receive the lights, instruments and dimmer resistance. It is engraved 'G/BOX' (gearbox oil temperature gauge), DIMMER (dimmer resistance), RESET (reset trip mileage indicator) and 5A (fuse holder).

213 The panel houses, a speedometer (10), tachometer (1), coolant temperature gauge (3), gearbox oil temperature gauge (7), fuel gauge (4), ammeter (5), dimmer resistance (6), 5 amp fuse (8) and eight panel lights (2).

214 The gasket (Fig 38(3)) provides a watertight seal between the metal panel and transparent panel.

215 The eight panel lights (Fig 37(2)) are controlled by the dimmer resistance and protected by the 5A fuse. The edge lighting principle is used, transmitting light through the transparent panel; window slots in the instruments permit the entry of light to illuminate the dials.

216 The 5A fuse is located in a panel fuse holder and is of the cartridge type.

217 The panel fuse holder (8) consists of a body and a fuse carrier of insulating material. The fuse fits into the bore of a screwed metal insert that engages with the body. Positive contact is made at the top and bottom end of the fuse by pressure exerted by a spring in the screwed metal insert.

218 Panel mounting is affected by a single hole shaped to grip the flattened anti-rotation body stem, the body being fitted with sealing washer and secured by a nut.

Speedometer No. 4, Mk 1

219 The speedometer records speeds up to 80 kph (50 mph), is has a non-linear scale with white numbers on a black background. The instrument is connected by a flexible shaft to the final drive, and is secured to the metal panel by brackets and knurled nuts. The total mileage indicator is at the lower part of the dial and records up to 99,999 miles and then automatically returns to zero; the upper part is the trip mileage indicator, this records up to 999.9 miles before returning to zero. A trip reset (9) operating shaft identified 'RESET' is connected to the trip mileage indicator to permit the indicator to be returned to zero

Tachometer No 1, Mk 1

220 The tachometer is an electric revolution indicator connected to a RPM sender unit No 1, Mk 1. The sender unit is driven by a takeoff from the spud gear on the scavenger air blower with an output of 1volt ac./100 rev/min driven speed. The tachometer is a permanent magnet moving coil type instrument with internal rectifier. A pointer deflection of approximately 270 degree covers the working range of the instrument. The scale is linear, graduated 0 to 50. The indicated reading is multiplied by one hundred to give engine speed. The moving coil system, mounted between parallel, jewelled bearings is hairspring damped so that the pointer movement is almost deadbeat. The tachometer indicates the output shaft speed and provides a check on speeds, which the engine should be operated under conditions of idling, driving and power tool operation.

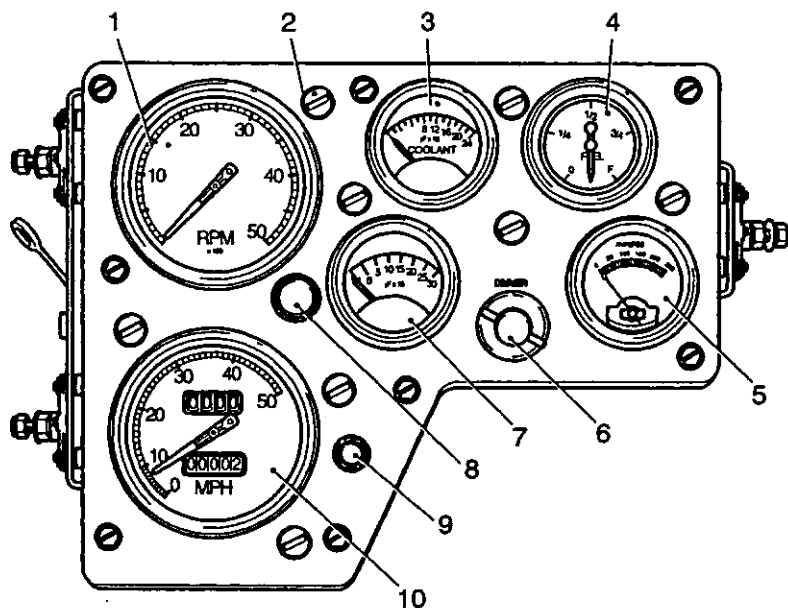

432/204

- | | | | |
|---|---------------------------|----|-------------------------------|
| 1 | Tachometer | 6 | Dimmer resistance |
| 2 | Panel light | 7 | Gearbox oil temperature gauge |
| 3 | Coolant temperature gauge | 8 | Fuse |
| 4 | Fuel gauge | 9 | Speedometer trip reset |
| 5 | Ammeter | 10 | Speedometer |

Fig 37 Instrument panel

Coolant thermometer

221 The coolant thermometer consists of two units; a gauge No 2, Mk 1 and thermometer bulb, connected electrically. The indicator dial is graduated to -4 to 24 and the indicated reading is multiplied by ten to give the coolant temperature in degrees Fahrenheit. The instrument is secured to the metal panel by brackets and knurled nuts.

222 The indicator has a double pivot moving coil element with two windings connected in a ratio meter circuit with a temperature sensitive resistance element contained in the bulb which is fitted to the exhaust side, front end, of the engine cylinder head.

223 The value of the current through the two windings determines the position of the pointer. One indicator coil winding is in series with the battery and earth and the second is in series with the battery, the bulb element and earth (Fig 3). The bulb resistance element is a wire wound combination of Nickel wire with a short length of Eureka wire attached. Its resistance increases as its temperature rises. The variation in resistance alters the balance of the currents in the two coil windings and the pointer therefore takes up a position corresponding to the temperature of the bulb.

224 Since the temperature indication depends upon the ratio of the currents in the two windings, it is independent of voltage variations. Similarly, the symmetrical arrangement of the circuit renders the indication free from errors due to changes in ambient temperature. The current consumption is approximately 40mA.

Gearbox oil thermometer

225 The gearbox oil thermometer is similar to the engine coolant thermometer consisting of the gauge (Electric Thermometer No. 2, Mk 2) (Fig 37(7)) in the panel which is connected to the bulb (Temperature Bulb No. 1, Mk 2) fitted in the gearbox to heat exchanger pipe. The thermometer is designed to cover a temperature range of -20°C to -1°C (-4°F to 30°F).

Fuel gauge

226 The fuel gauge consists of two units, the indicator in the instrument panel, and the unit in the right fuel tank. They are connected together by three wires (Fig 3) and work on the Desynn principle.

Tank unit

227 The tank unit (Fig 38) consists of a transmitter operated by the rise or fall of a float arm due to alteration in the level of the fuel in the tank. The transmitter comprises a uniform toroidal resistor (8) tapped at three equally spaced points. Two contacts bear on the resistor at diametrically opposite points; they are mounted on sliders (7), which are insulated from each other and from the unit and are connected to the vehicle supply (Fig 3). The sliders are linked mechanically, via driving lever (Fig 38(9)), to a shaft, which is rotated by the rise and fall of a float (1). This motion is transmitted by a pinion (12) fitted to the bottom of the shaft, which engages a gear (13) cut on the face of the float arm carrier.

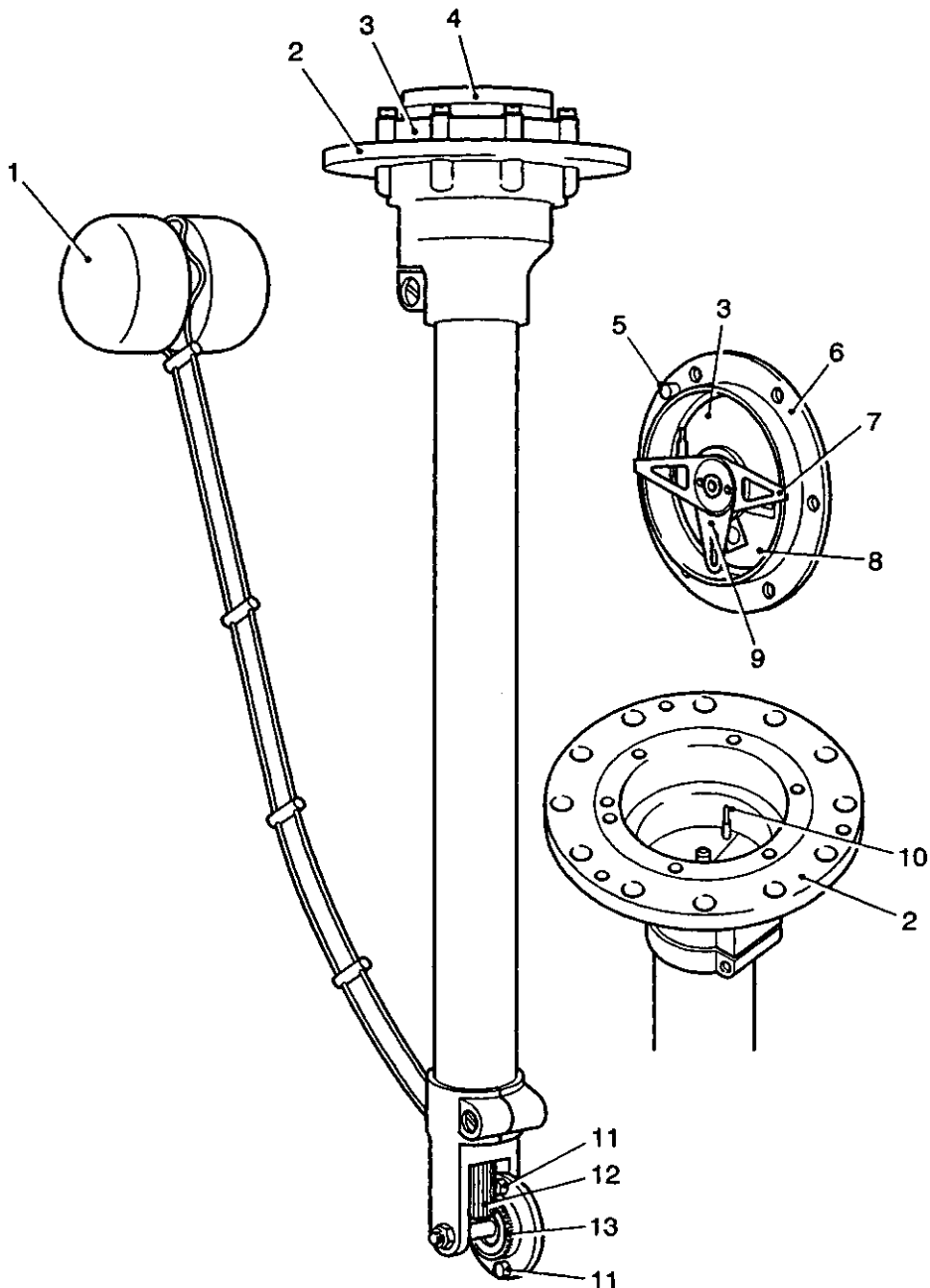

432/393

- 1 Float
- 2 Mounting flange
- 3 Resistor housing
- 4 Terminal cover
- 5 Locating pin
- 6 Gasket
- 7 Slider

- 8 Resistor
- 9 Driving lever
- 10 Driving pin
- 11 Float arm stop
- 12 Pinion
- 13 Gear

Fig 38 Fuel gauge tank unit

228 The gear is pinned to a sleeve type bearing and is carried by a spindle with a screw thread at one end and a screwdriver slotted head at the other. The spindle is locked by a self-locking nut and at the head by a solder seal.

Indicator

229 The indicator consists of a small iron stator carrying a star-connected three-phase distributed winding. Accurately balanced and supported in bronze bearings, is a 2-pole permanent magnet rotor which is free to move within the stator field and which carries the indicator pointer.

Operation

230 With the engine switch 'on' the transmitter, tapings are connected to the indicator windings; the position of the transmitter contacts determines the distribution and strength of the current flowing in the windings. The resultant magnetic field, and therefore the position taken up by the rotor and pointer, aligns itself with the position of the transmitter contacts and an indication is given of the quantity of fuel in the tank. The direction and disposition of the magnetic field are not dependent upon the applied voltage and therefore variation in voltage does not affect the indicator reading.

Ammeter No. 5, Mk 1

231 The ammeter is of waterproof construction, the leads are brought out of the watertight glands and terminate in Lucar connectors and is secured to the metal panel by two nuts and a strap. The meter is a moving coil instrument with a linear scale calibrated for 0 to 250 amperes. It is used with an external shunt located in the lower compartment of the rectifier unit, which is connected to the dc positive line.

232 The pointer and scale of the instrument are luminous and the leads are identified +ve and -ve.

Dimmer resistance

233 The dimmer resistance comprises a 150 ohm resistance unit, a bracket, an extension rod, a sealed spindle and a control knob. The resistance unit is secured to the bracket by a hexagon nut and a lock washer supplied with the unit. To the resistance unit shaft is pinned the extension rod which is slotted to receive the sealed spindle. The bracket is secured to the metal panel and the transparent panel by four cheese headed screws, sealing washers and nuts. To the sealed spindle is fitted the control knob. The dimmer resistance permits illuminating intensity to be varied to suit requirements; with the control knob in the fully anti-clockwise position the wiper arm leaves the resistance track and the supply is broken.

Panel lights

234 The eight panel lights are fitted with clear lens with serrated black opaque caps. The body of the light is secured to the metal panel by a lock washer and hexagon nut, which compresses a rubber sealing ring against the counter bore in the transparent panel. Flanged midget lamps are fitted.

235 Electrical connections are made to the panel by AN type plugs and sockets.

HORN No. 1, MK 1

Horn push button

236 The horn push button is fitted to a bracket adjacent to the driver's instrument panel. The unit consists of a small cast aluminium box to which is bolted a metal clad push button switch, which has normally open electrical contacts. External connections are made to the box through an AN type plug. The switch is connected to the battery supply through CB B (or fuse B) and operates the traffic horn.

Traffic horn

237 A traffic horn is mounted on the front sloping plate of the vehicle adjacent to the right headlight. It is a waterproofed model of normal design, consisting of an electro-magnet whose 2.15/2.55 ohm operating coil is connected in series with a contact breaker and with the horn push switch.

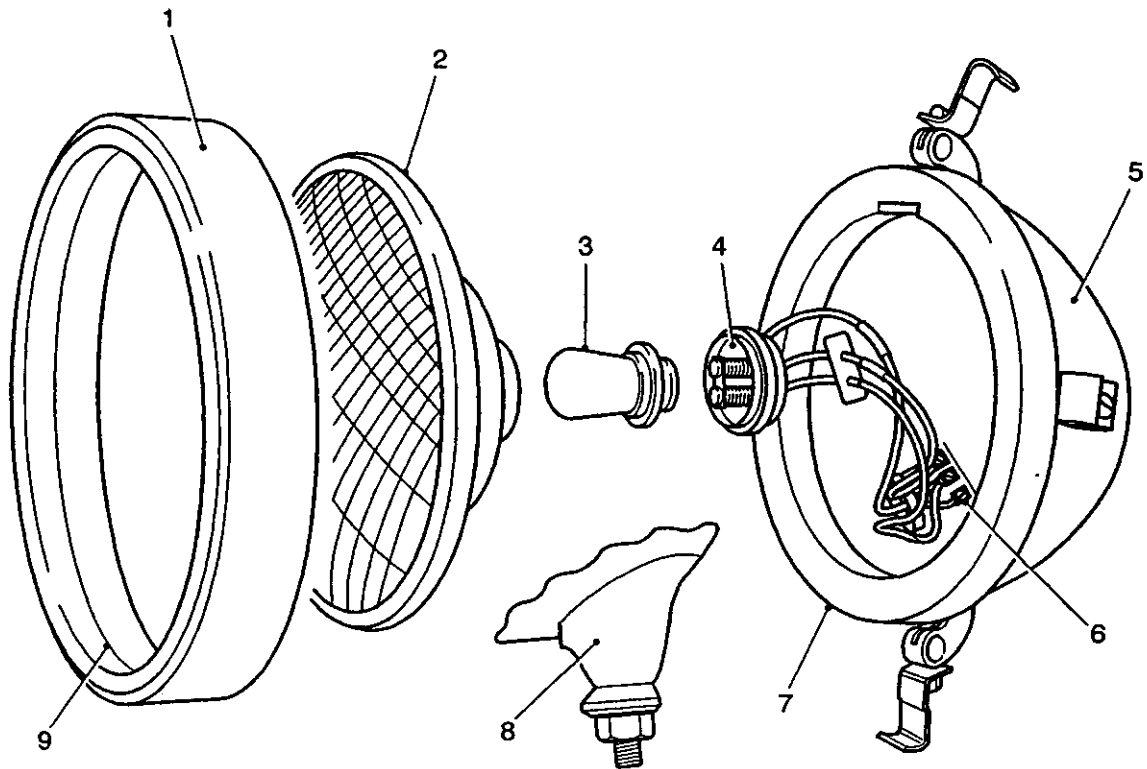

432/397

1	Rim	4	Adaptor	7	Rear gasket
2	Light unit	5	Body	8	Stem mounting
3	Lamp	6	Terminal block	9	Front gasket

Fig 39 Headlight

Infra red driving light No. 1, Mk 1

249 The Infra Red (IR) driving lights are the inner pair of lights mounted on the same channelling as the headlights. The general design of the light is similar to that of the headlights.

250 A 100/100-watt lamp (Fig 40 (3)) with a European cap (4) is located in the light unit (1) by a key and is secured by a spring wire clip (2). At the back of the cap are three blade connectors to receive a connection socket (5).

251 When the IR driving conditions are in force, a filter unit is secured to the front of the light by the rim securing clips. Under these conditions when switched on, the light should not be visible to the naked eye but heat from the lamp should be felt.

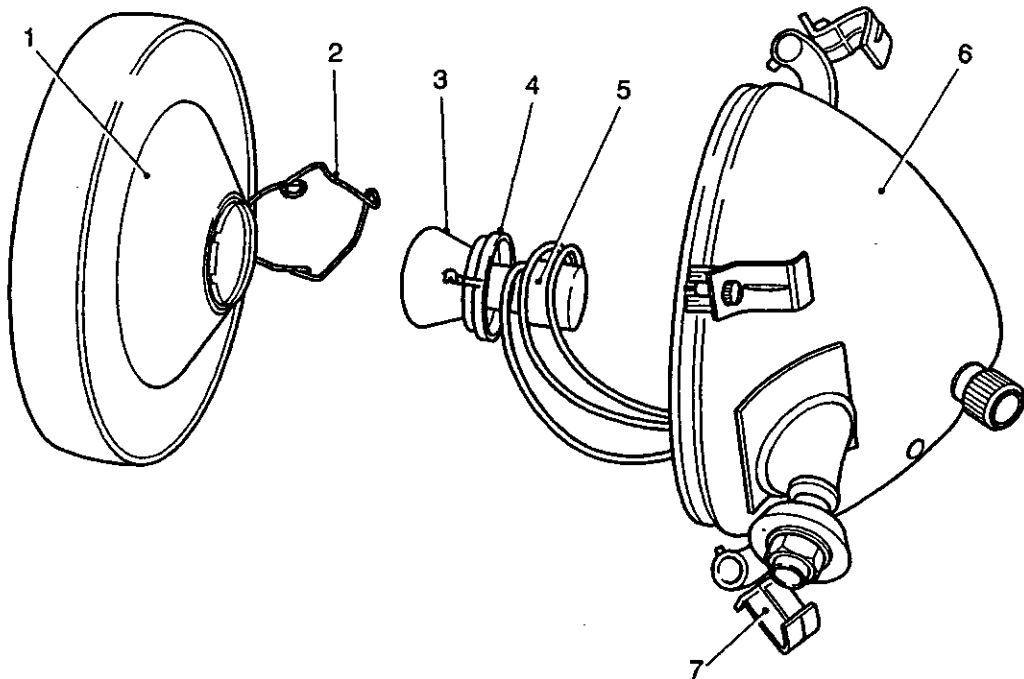

432/398

- | | | | | | |
|---|---------------------|---|------------------------|---|--------------------------|
| 1 | Light unit | 4 | Lamp cap | 7 | Light unit securing clip |
| 2 | Lamp retaining clip | 5 | Lamp connection socket | | |
| 3 | Lamp | 6 | Body | | |

Fig 40 IR driving light

Side light No. 3, Mk 3

252 A sidelight (Fig 41) is mounted below each headlight. Each light consists of a metal base, a moulded rubber body and a metal cased lampholder with a 6-watt SCC lamp and a lens.

253 The base (1) is secured to the light mounting bracket by three screws and nylon insert nuts. It is in the form of a shallow cup threaded to accommodate the lens.

254 The body (7) is tubular with a flanged head, its stem locates in a hole in the base and mounting bracket with its head seating in the base. Three small projections on the body lightly hold the base against the body flange. At the rear end of the body is a gland (8) to which the vehicle cable sealing cone and gland nut is fitted.

255 A single contact lampholder assembly (3) is flanged to seat in the head of the body with its rim located in the body recess. Two ferrules (2 and 4) are provided to which the vehicle cables are fitted and then pushed into eyelets fixed to the holder contact and to the holder case.

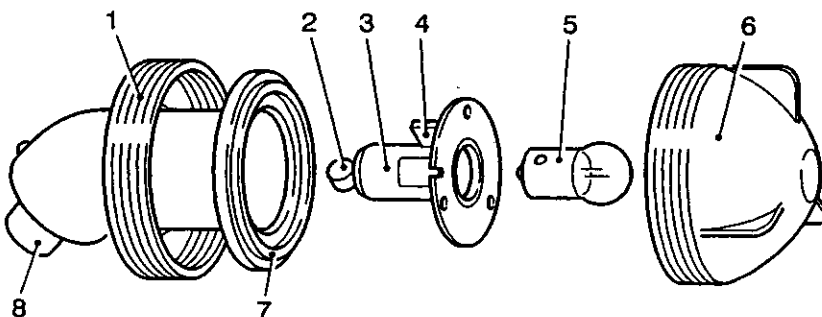

432/095

- | | | | | | |
|---|---------------------|---|---------------|---|-------------|
| 1 | Base | 4 | Earth ferrule | 7 | Body |
| 2 | Contact ferrule | 5 | Lamp | 8 | Cable gland |
| 3 | Lampholder assembly | 6 | Lens | | |

Fig 41 Sidelight

256 A clear glass lens (6) is used, it is optically formed on the inside to give the desired light spread and has a thread on its periphery and four webs on its front face to facilitate screwing it in or out of the base.

Turn light No. 3, Mk 1

257 The turn lights are similar to the sidelights but have an amber lens. They are fitted adjacent to the side and tail lights, on the inner side.

Tail stop light No. 3, Mk 1

258 The two tail-stoplights are fitted to the rear of the vehicle and are similar to the sidelights but have a different lampholder and are fitted with a red lens.

259 The lampholder is of the double contact index pin type housing a twin filament (6W/24W) lamp. The 6W filament is the taillight and the 24W filament is the stoplight. Staggered pins on the lamp and staggered slots in the holder ensure that the lamp is correctly fitted.

Registration plate light No. 1, Mk 2

260 The registration plate light (Fig 42) is a waterproofed unit consisting of a front cover assembly, backplate and bush, lampholder and rear case, and bush assembly.

261 Six tapped holes are provided in the backplate (12), three are used for securing the front cover (3) and three for securing the light. The lampholder (11) is supported by front (10) and rear (5) rubber mountings which locate in the bore of the backplate bush and is secured by a locking ring (6) which screws on the bush and clamps the rear case against the rear mounting. A cable ferrule is attached to a cup (8) in the rear mounting to receive the negative connection.

262 The front cover is cylindrical with a 180 degree light aperture. Fitted on the cover is a spring loaded light shield (14) with a light aperture to coincide with the cover aperture and diametrically opposite is a 9.5 mm (3/8in.) dia hole. The shield is slotted to engage a locating peg and may be rotated on the cover within the limits set by the peg to give full or restricted illumination.

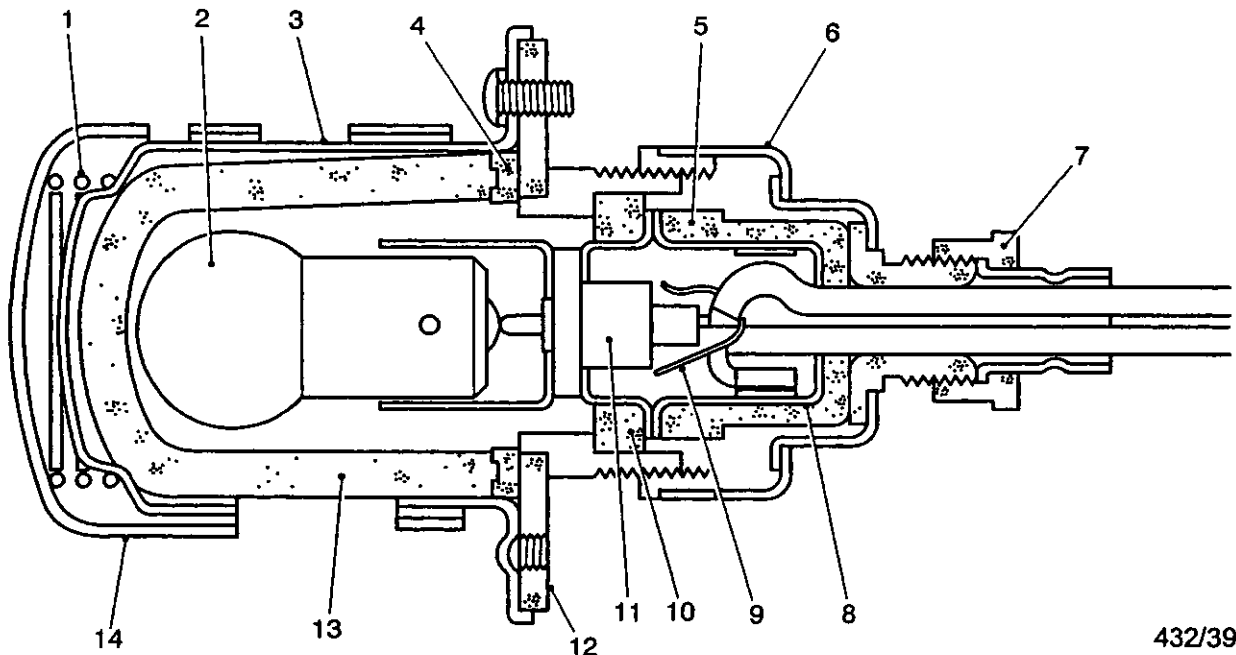

432/395

- | | | | | | |
|---|----------------------|----|-------------------------|----|--------------|
| 1 | Light shield spring | 6 | Locking ring | 11 | Lampholder |
| 2 | Lamp | 7 | Cable bush nut | 12 | Backplate |
| 3 | Front cover | 8 | Negative connection cup | 13 | Lens |
| 4 | Gasket | 9 | Terminal cover | 14 | Light shield |
| 5 | Rear rubber mounting | 10 | Front rubber mounting | | |

Fig 42 Registration plate light

Convoy light No. 2, Mk 5

263 The convoy light (Fig 43) is fitted to illuminate the convoy markings on the rear door. It has a mushroom shaped metal body (3) the stem of which is threaded to accept a securing nut (11). A rubber mounted centre contact lampholder seats in the bore of the body and is retained in position by a circular nut (6) screwed on the stem, which presses a rubber sleeve (5) against the lampholder flange. Interposed between the sleeve and the nut are a friction washer (8) and the flange of a cable entry bushing (7). A negative cable ferrule is attached to the lampholder metal sleeve.

264 A screw cap (16) fitted to the body of the lamp has a plain polystyrene lens (14) to permit illumination of the convoy markings, and a small ruby lens (1), which permits a small red light to be visible to the driver of a closely following vehicle in convoy.

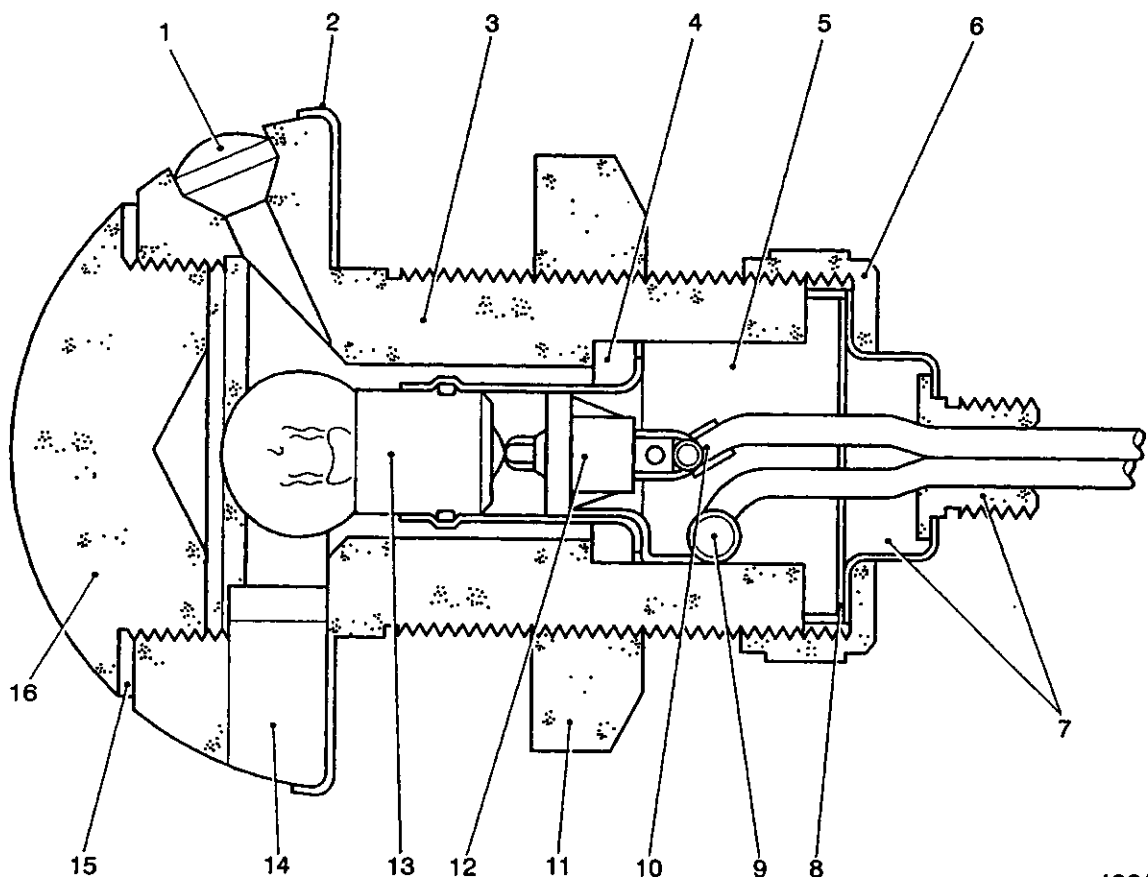

432/396

1	Convoy lens	7	Cable bushing	13	Lamp
2	Back plate	8	Friction washer	14	Lens
3	Body	9	Negative connection	15	Gasket
4	Lampholder mounting bush	10	Positive connection	16	Cap
5	Rubber sleeve	11	Securing nut		
6	Locking ring	12	Securing clip		

Fig 43 Convoy light

Gear range selector switch

265 The gear range selector switch (Fig 44) is bolted to the gear range selector case and consists of a snap-action, two circuit change over switch enclosed in a plastic case.

266 At the top of the switch is a bracket carrying a spring loaded hinged lever (4), which engages a plunger (6) to operate the switch. Pinned to the free end of the lever is a nylon roller (3), which is engaged by a knife edged striker (2) attached to the selector lever.

267 One pole of the switch is normally closed and is connected in series with the side and turn lights, the second pole is normally open and is connected in series with the starter motor solenoid. When the selector lever is in neutral, the striker engages the switch lever roller and the switch is actuated to break the side and turn lights circuits and to make the starter motor solenoid circuit. When the lever is moved from neutral the switch reverts to normal so preventing the operation of the starter motor and permitting the operation of the side and turn lights.

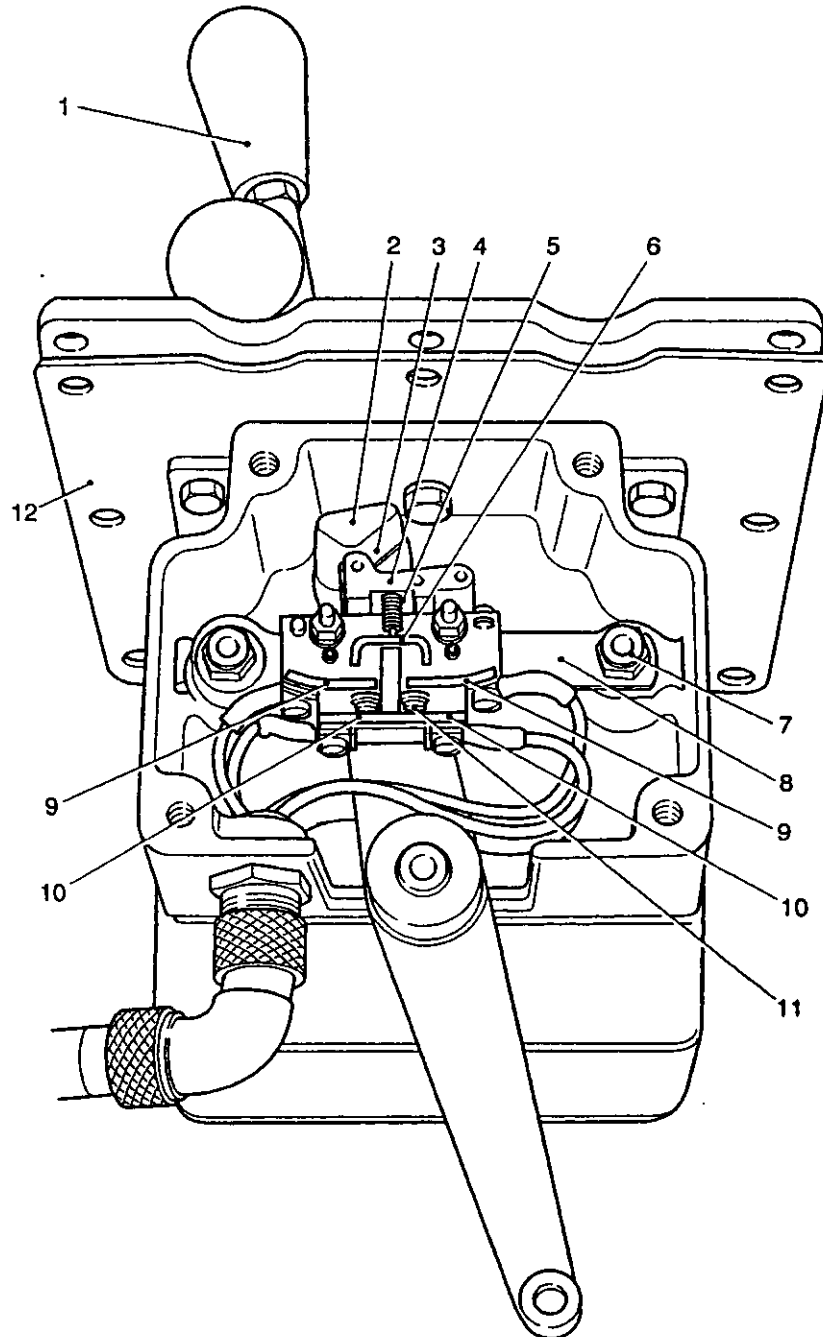

432/452

- | | | | |
|---|----------------------------|----|---|
| 1 | Gear range selector handle | 7 | Switch carrier securing bolt |
| 2 | Striker | 8 | Switch carrier |
| 3 | Roller | 9 | Fixed contacts - starter solenoid circuit |
| 4 | Switch operating lever | 10 | Fixed contacts - stop and turn lights circuit |
| 5 | Lever spring | 11 | Moving contacts |
| 6 | Plunger assembly | 12 | Gasket |

Fig 44 Gear range selector switch

Trailer relay assembly

268 The FV436 ASV may not have a trailer relay assembly fitted, however the trailer harness and the trailer socket have been removed, therefore, the operation or description of the unit is not included.

Operation of external lighting

269 A battery supply is connected to the hinge (mid) points of one pole of the NORMAL/BLACKOUT switch and of the CONVOY switch (Fig 3). The circuit is arranged so that for normal operation these two switches must be at NORMAL and at off respectively. In this condition the stop and turn light circuits are energized irrespective of the switch positions of the other two switches.

270 Operation of the TAIL-SIDE switch will bring the tail, side and registration plate lights into circuit and will energize socket 'E' of the trailer socket. Putting the HEAD switch to on will bring the headlights into circuit.

271 If the CONVOY switch is put to CONVOY the stop and turn lights are inoperative, the tail, registration plate and headlight circuits are also broken but with the TAIL-SIDE switch 'on' the sidelights are energized. Sockets A, C and H of the trailer socket are also energized.

272 If NORMAL/BLACKOUT switch is put to BLACKOUT the stop and turn lights are inoperative and the side, head and registration plate circuits are broken. The IR switch is energized and putting this switch 'on' brings the IR lights into circuit. With the CONVOY switch 'off' the taillights may be brought in circuit via the TAIL-SIDE switch. With the CONVOY switch at CONVOY the convoy lights are brought into circuit.

273 Table 1 summarizes the switching arrangement; with the toggles up the switches are in the positions designated OFF in the table, the down position being designated ON.

TABLE 1 EXTERNAL LIGHTING SWITCHING ARRANGEMENT

Switches				Lights						
Blackout	Tail side	Head IR	Convoy	Tail	Side	Head	Registration Plate	Convoy	IR	Turn and stop
Normal working										
OFF	OFF	OFF	OFF	-	-	-	-	-	-	Operative
OFF	ON	OFF	OFF	ON	ON	-	ON	-	-	Operative
OFF	ON	ON	OFF	ON	ON	ON	ON	-	-	Operative
Convoy working										
OFF	OFF	OFF	ON	-	-	-	-	ON	-	-
OFF	ON	OFF	ON	-	ON	-	-	ON	-	-
Blackout working										
ON	OFF	OFF	OFF	-	-	-	-	-	-	-
ON	OFF	OFF	ON	-	-	-	-	ON	-	-
ON	ON	OFF	OFF	ON	-	-	-	-	-	-
ON	OFF	ON	OFF	-	-	-	-	-	ON	-
ON	ON	ON	OFF	ON	-	-	-	-	ON	-
ON	OFF	ON	ON	-	-	-	-	ON	ON	-

Fascine lighting

274 To comply with current lighting regulations; two three pin sockets have been mounted on the external rear of the vehicle, each one inboard and below the turn lights. Each socket is wired directly to the taillights and is live whenever the taillights have power supplied to them, ensuring, whenever the fascine lights are connected, they are still controlled by the vehicle blackout system.

275 To comply with current road regulations, the vehicle is equipped with a roof mounted rotating beacon, positioned centrally at the rear of the roof and locked into a vertical pipe type mounting by a locking lever. Its associated electrical lead is tie wrapped to cleats on the rear of the vehicle and plugs into the fascine lighting socket detailed above.

Spotlight No. 1, Mk 1

276 The spotlight is similar to the headlight, the same type of light unit and lamp is fitted but, in this instance, only the main filament is used. The light has an on-off switch and 30 ft of cable, which terminates in a 2-pin plug to fit into the distribution panel sockets or the sockets in the power pack compartment.

277 A bracket is provided for mounting purposes and this is connected to the light via a right-angled bracket and two turn-buttons, which permit the light to be easily swivelled or deflected. The light is stem mounted to the bracket. A ball and socket joint between the light body and stem, and a handle attached to the body provides another method of controlling the direction of the light after slacking off the stem nut.

278 When not in use the cable may be wrapped round the body to locate against the stem, handle and two brackets fitted at each side of the light. A dummy socket to house the plug is fitted to the light handle.

INTERIOR LIGHTING

279 Interior lighting is provided by six lights of the combined switch and dimmer type. The six lights are controlled by switch No2 on the Auxiliary Junction Box (AJB) and by a door-operated blackout switch (Fig 45).

280 The two switches are connected in parallel with each other and for normal working, the AJB is put to 'ON', thus short circuiting the blackout switch and rendering it inoperative. When working under blackout conditions the junction box switch is put to the 'off' position and the lights are then controlled by the blackout switch, opening the rear door of the vehicle breaks the interior lighting circuit.

281 The six lights are divided into two circuits, the driver's light and the two front lights in the personnel compartment being one circuit and are protected by fuse F2 (5A) in the AJB. The Commander's light and the two rear lights in the personnel compartment are protected by fuse F4 (5A). Both circuits are protected by the 10A fuse F5 in the AJB and by fuse A (15A) in the distribution panel.

282 Additional lighting is required in the Command Role and for this purpose; a take-off socket is located near, and connected to, the rear light and to the front left light in the personnel compartment.

Roof light No. 3, Mk 1

283 Each light is mounted on a felt pad and is secured by a centrally disposed felt bush and a bolt; the pad and bush being secured to the roof and light base respectively by adhesive compound. The light is circular and consists of a switch and a variable resistance, which permits illumination intensity to be varied to suit requirements. It comprises two major sub-assemblies; a base with handle and switch contact piece; and a body with resistance unit, shield and lamp, the two sub-assemblies being secured together by three screws.

284 The switch has 74 degrees of rotation, the first 14 degrees of movement being from the OFF to the DIM position. It has a contact piece, which wipes the resistance and is engaged by a spring-loaded plunger. The pins of the lamp locate against the back of the body; slots for the pins are provided in the body to permit the fitting and removal of the lamp. The lamp centre contact engages a contact piece connected to the switch plunger.

285 The lamp shield is of the cowl type; its periphery has a series of holes spaced to permit an all round light cut-off of 15 degree as required. To identify this positioning, letters are embossed on the body and a pointer is attached to the shield.

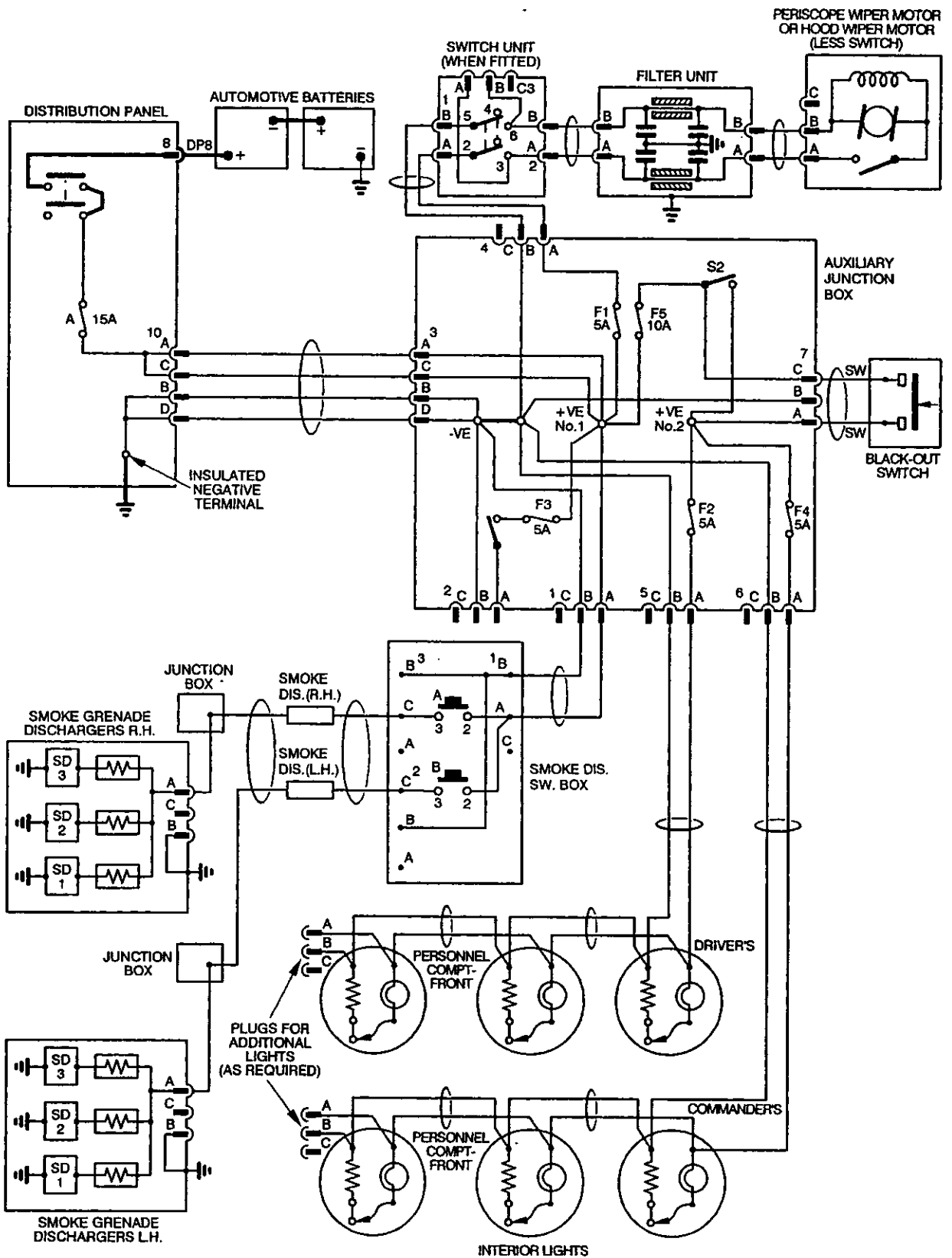
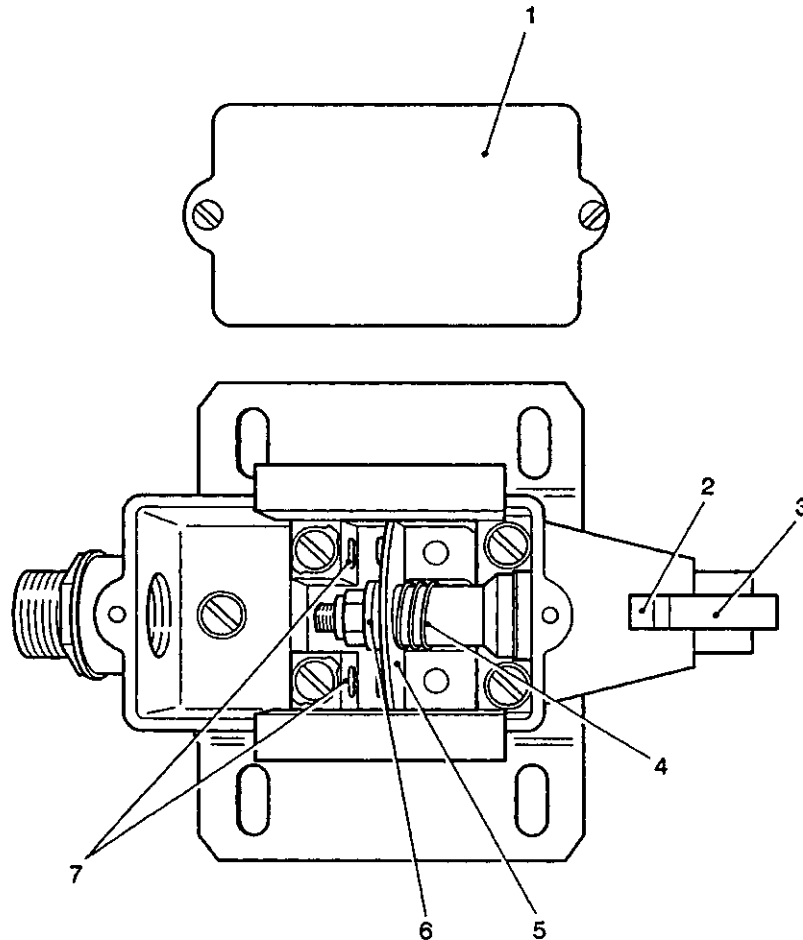

Fig 45 Diagram of auxiliary junction box and associated circuits

Blackout switch - Craig and Derricott type VSP1

286 The blackout switch (Fig 46) is located adjacent to the top left corner of the rear door on the inside of the vehicle. It has a roller (3) attached to the end of the plunger (2), which is engaged by a bracket on the door to close the switch contacts when the door is closed.



432/390

- | | | | |
|---|----------------|---|-------------------|
| 1 | Cover | 5 | Plunger contact |
| 2 | Plunger | 6 | Insulating washer |
| 3 | Roller | 7 | Fixed contact |
| 4 | Contact spring | | |

Fig 46 Blackout switch

SMOKE DISCHARGER JUNCTION BOX No. 3, MK 1

287 The smoke discharger junction box (Fig 1(18)) is located to the rear of the driver's hatch adjacent to the accessories control box (15). Attached to the box are two push buttons, which control respectively the right and left smoke grenade dischargers. The circuit (Fig 45) is live when the battery switch on the distribution panel is switched ON.

RADIO FREQUENCY FILTER UNIT No. 3, MK 1

288 The filter unit is located to the left of the driver's hatch and is connected in the positive and negative supply lines from the auxiliary junction box (Fig 45) to suppress interference to the radio equipment from the driver's periscope wiper motor or the driver's hood wiper motor.

289 An AN type plug on the unit receives the connection from the auxiliary junction box and an AN type socket receives the connection from the periscope wiper motor or the hatch wiper motor as required.

290 The components of the filter are contained in a waterproofed brass case and consist of two bushing assemblies connected one in each supply line.

291 Each bushing assembly comprises a ferrite core and two metallised paper capacitors mounted on a tinned copper stem and enclosed in a tinned brass tube the ends of which are spun over and filled with epoxy resin. Soldered to each end of the stem is a connection tag, which is connected to the inlet plug and outlet socket respectively.

292 The ferrite core is centrally disposed on the stem and is retained in position by copper gauze soldered to the stem at each end of the core. Each capacitor is wound on an insulated tube, the inner face of the capacitor sections being soldered to the gauze and the outer face to a brass perforated disc, which in turn is soldered to the enclosing tube. The capacitor is thus connected to the conductor stem and to the tube. A PVC tapered plug locates the stem in the capacitor-insulated tube.

293 The two bushing assemblies are each soldered to two-brass mounting brackets which in turn are soldered to the case. A brass lid soldered to the case presses against two contact strips soldered to the mounting brackets.

294 The capacitance of each line to the case is between 0.9 microfarads and 1.8 microfarads between frequencies of 50 c/sec and 2,000 c/sec. The attenuation of each leg is at least 70 dB over a frequency range of 1-150 Mc/sec.

DRIVER'S PERISCOPE WIPER MOTOR

295 This motor drives the driver's periscope wiper. It is a two pole, shunt wound machine, which develops a torque of 16 oz in. at a speed of 2,000 rev/min (minimum), 3,100 rev/min (maximum) between a voltage range of 22-30V. It has a no-load speed of 3,550 rev/min at 28.5 volts and an output of 1/23 HP at 2,740 rev/min.

296 The two pole pieces (Fig 47) are each secured to the yoke (7) by a countersunk headed screw and by a hexagon headed screw, the former screw being fitted at the driving end (DE) side of a centrally disposed mounting flange embodies on the yoke. Each shunt coil (4) has a resistance of 39.5 ohms at 15 deg C.

297 Two end brackets spigoted to the yoke are clamped together by two through bolts with Nyloc locknuts.

298 Sealed type ball bearings packed with grease are used to support the armature which has a resistance of 2.4 ohms measured across the brushes at 15°C. At the DE circlips retain the bearing in the end bracket (3) and against a shoulder on the shaft, and a pre-loaded wave washer (16) fitted between the bearing and its housing restricts the armature end float.

299 Two brush holders (14) fitted to the Commutator E (CE) bracket each hold a brush (15) which, when new, is spring-loaded to a pressure of 4 1/2 lb sq in. The length of a new brush is 1/2 in. A moulded cap (11) screws on to the holder to retain the brush and spring (12).

300 Six screws and spring washers secure a cover (10) and gasket (9) to the CE bracket.

301 Teeth cut on the DE of the shaft engage the gear train, six screws being used to secure the motor and a gasket to the gearbox.

302 Two leads from the motor are connected to a terminal board located beneath a cover at the bottom of the gearbox. From the terminal board connection is made to a single pole toggle switch located at the top of the gearbox adjacent to the motor and to an AN type connection plug at the bottom of the gearbox which in turn is connected (Fig 45) to the RF filter unit.

303 The switch toggle locates in a hole in an L shaped bracket which mechanically interlocks with the wiper arm lever assembly when the wiper arms are in the 'parked' position and so prevents the motor from being switched on whilst the arms are parked. The switch is operated by movement of the bracket.

304 Incorporated in the gearbox is a clutch to safeguard the motor in the event of fouling up of the wiper arms. The clutch is set to slip at 7.5 Nm (66 in.lb) (max) measured at the wiper spindle remote from the gearbox.

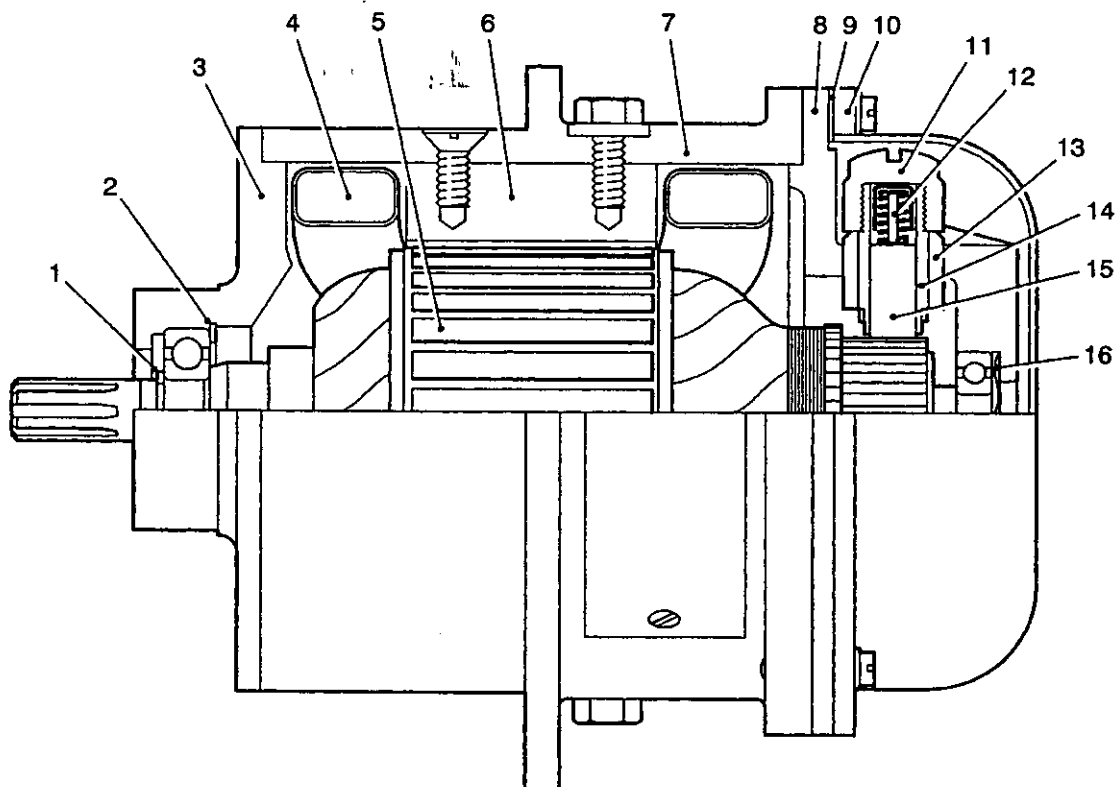

432/262

1	Armature circlip	7	Yoke	12	Brush spring
2	Bearing housing circlip	8	CE bracket	13	Brush holder carrier
3	DE bracket	9	Cover gasket	14	Brush holder
4	Field coil	10	CE cover	15	Brush
5	Armature	11	Brush holder cap	16	Wave washer
6	Pole piece				

Fig 47 Periscope wiper motor

MOTOR DRIVING NO 8, MK 1 (FAN)

305 Driving motor No 8, Mk 1 (Fig 48) is the motor, which drives the fan of the Ventilation System.

306 Six screws with tab washers secure a mounting plate (Fig 49(11)) to the motor driving end (D.E.) bracket (9) and the mounting plate is bolted to the fan casing by eight screws and tab washers.

307 Located on the (D.E.) of the shaft is a mild steel spinner (10) followed by a fan (12) having aerofoil type blades. The fan is keyed to the shaft and is retained by a nut and tab washer.

308 The motor is a totally enclosed, fan cooled, compound wound machine with interpoles. It is a variable speed unit, continuously rated and capable of developing 0.27 H.P. at 24V 4,500 rev min with zero external resistance and 0.9 H.P. at 24V 7,150 rev min with 28 ohms external resistance (motor hot); it is designed to operate within a voltage range of 22V minimum and 29V maximum. Rotation is anti-clockwise when looking on the D.E. and speed variation is obtained by a variable resistor connected in series with the shunt coil. Radio interference suppression components are housed in the motor terminal box.

310 The field system comprises four main poles and four inter-poles each being secured to a steel yoke by two screws. Each main pole winding consists of a 1.7 ohm shunt coil and a 0.008 ohm series coil; the shunt coils are connected in series with each other and the series coils are connected in series - parallel with each other and with the armature. The inter-pole coils each have a resistance of 0.011 ohms and these are connected in series with each other and with the armature. All resistance values quoted are as measured at 20°C.

311 Sealed ball bearings packed with grease are used to support the 0.011 ohm lap wound armature. The bearings are housed in steel liners (Fig 48(4) and (11)) fitted to aluminium alloy brackets spigoted and bolted to the yoke (20). The bearings locate against shoulders on the armature shaft and at the commutator end (CE) the inner member of the bearing is clamped against the shoulder by a spacer (2), fan (3), tab washer (1) and nut. The outer member is clamped by a bearing cap (26) with shims and sealing washer, four screws secure the cap to the bracket (5).

312 At the DE the bearing is retained in its housing by inner (16) and outer (15) bearing caps, each being secured to the end bracket by three screws. Bearing shims (12) and a pre-loading wave washer (14) are fitted between the bearing and the outer bearing cap, the number of shims being adjusted to give a bearing spring force of 3.6 kg - 4.5 kg (8 lb - 10 lb).

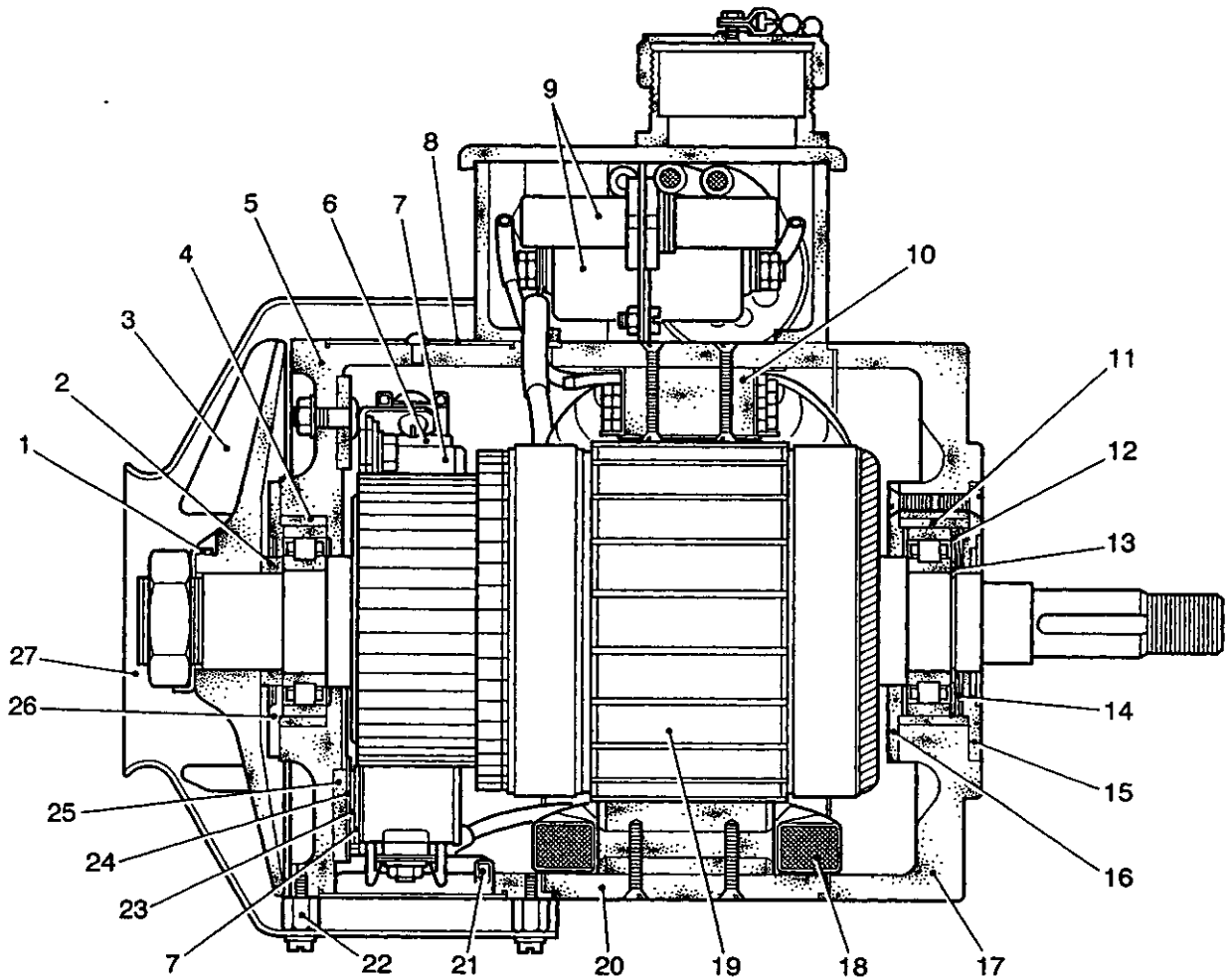

432/363

1	Tab washer	10	Inter-pole	19	Armature
2	Spacer	11	Bearing liner	20	Yoke
3	Fan	12	Bearing shims	21	CE bracket securing screw
4	Bearing liner	13	Circlip	22	Fan cover pillar
5	CE bracket	14	Wave washer	23	Insulating washer
6	Brush	15	Bearing outer cap	24	Insulating plate
7	Brush box	16	Bearing inner cap	25	Brush gear ring
8	CE bracket band	17	DE bracket	26	CE bearing cap
9	Capacitors	18	Field coil	27	Fan cover

Fig 48 Fan driving motor

313 Four brush boxes are bolted to a brush gear ring, insulating plates, washers and bushes being used to insulate them from the ring. Two screws with nuts and spring washers are used to secure the brush gear assembly to the CE bracket, these screws locate in slots in the brush gear ring to facilitate brush positioning. A brush pressure of 624 g (22 oz) is provided by Tensator constant force stainless steel springs, which maintain constant pressure throughout the brush life (length of new brush 19 mm (0.75 in.), minimum worn length 6.4 mm (0.25 in.).

314 A steel band encloses the CE bracket.

315 As already described, the cooling fan (Fig 48(3)) is mounted externally to the CE bracket; it is protected by a steel cover, (27), which is bolted to four pillars (22) attached to the CE bracket. The cover directs the cooling air over the external surface of the motor.

316 Connection to the motor is made via an AN type plug fitted to the motor terminal box. Pins B, E and G are connected to the motor via bushing capacitors (9) housed in the terminal box. Pins C, D and F are heater connections and leads from these pins are connected direct to sockets C, D and F of an AN type socket also fitted to the terminal box. A captive cover is provided for the socket when the heater is not connected, and a housing for the cover when the heater is connected, is attached to the terminal box cover.

317 The motor is connected to the ventilation batteries through a switch, a relay and by the controller.

318 On certain fan units, No 4 Mk 1, (FV 564270 5.1 in. fan) the motor driving No 9 Mk 1 (FV 546142) may also be fitted with a diode fitted across the shunt field coils. This will be denoted by the erasure of the 'Fig 1' on the motor modification record plate

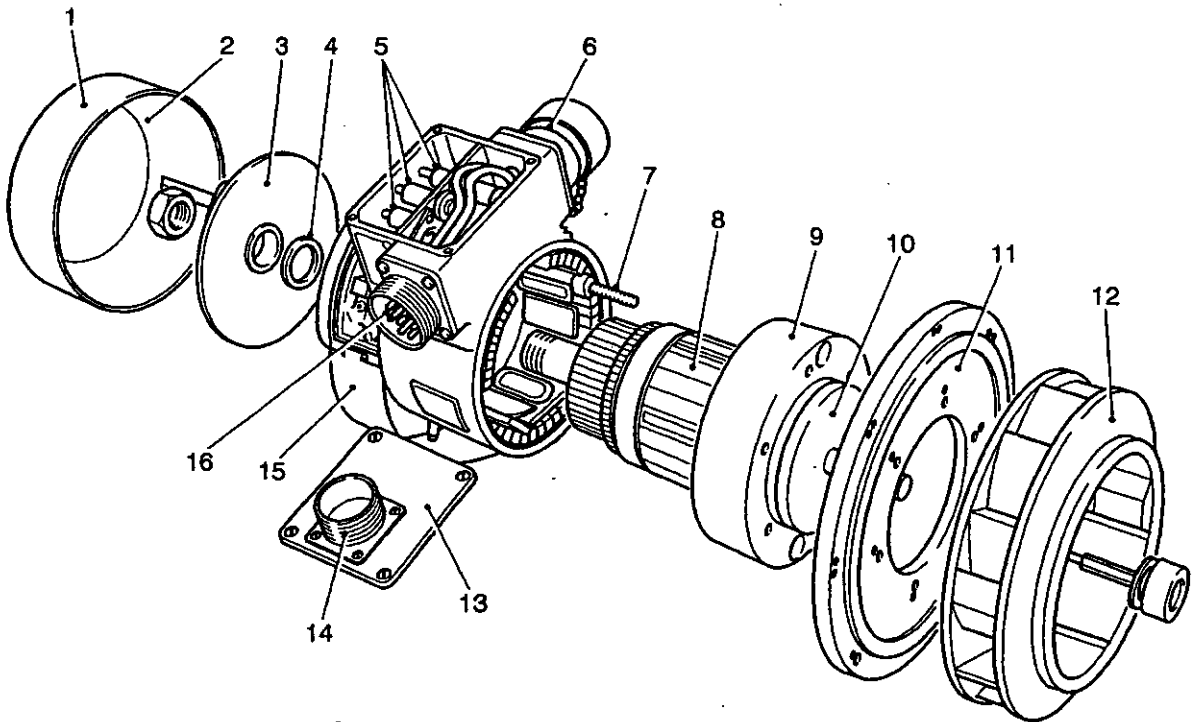

432/361

1	Air inlet gauze	9	DE bracket
2	Fan cover	10	Spinner
3	Fan	11	Mounting plate
4	Spacer	12	Fan
5	Capacitors	13	Terminal box cover
6	Socket for heater connection	14	Housing for heater connection socket cover
7	DE bracket retaining bolt	15	CE bracket band
8	Armature	16	Plug for accessories control box connection

Fig 49 Driving motor - exploded view

CONTROLLER FAN No1, Mk 2

319 The fan controller is mounted on the partition plate immediately forward of the fan. It consists of a 5-position rotary switch housed in an aluminium alloy box. The switch is designed for ac and dc operation, the dc control used in this installation is obtained by turning the switch knob clockwise from the off position, an index plate is attached to the controller cover.

320 The switch knob is of two-piece construction secured together from the underside by two screws. Clamped between the two sections of the knob is a 'U' shaped contact piece one arm of which engages in sequence a ring of contact studs and the other arm engages one or other of two contact plates fitted one at each side of the studs. The studs and plates are mounted on a base plate of insulating material, which is bolted to pillars cast in the box.

321 Keyed to the switch knob is a spring index piece housing two steel balls, which locate in indents in the knob support bracket to locate the switch positions. The support bracket is attached to the base plate. A blob of white paint applied to the knob identifies the switch position.

322 The contact studs are located four on either side of two diametrically opposite OFF position studs and are connected to three resistors mounted on the underside of the base plate.

323 Connections to the controller are made to three grub screw type terminals on the base plate. Cooling the resistors is effected by apertures in the ends of the box.

324 Turning the switch knob from OFF to 1 on the dc side connects the ventilation batteries, via the FAN switch on the accessories control box, to the shunt field of the fan motor and through the three resistors (28 ohms total) to the coil of the fan relay in the same control box. The relay closes and connects the ventilation batteries to the fan motor armature and the motor runs at its slowest speed.

325 Advancing the knob to position 2 inserts the first resistor (5 ohms) in the shunt circuit and the motor increases in speed. Advancing to position 3 adds the 7 ohm resistor to the shunt circuit and results in a further increase in speed. At position 4 all resistors are included in the shunt circuit and maximum speed is obtained.

BOWMAN RADIO SYSTEM

REDACTED

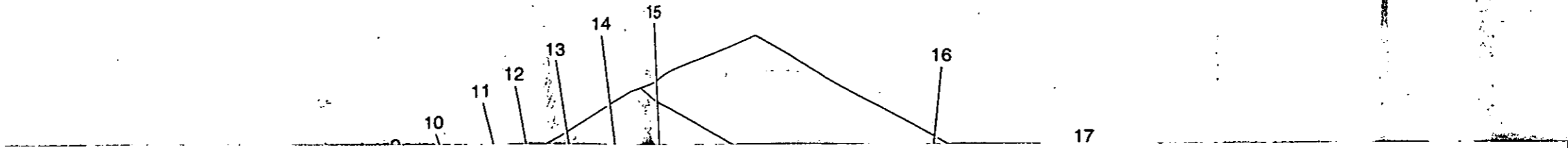

REDACTED

X

430/20136

Fig 50 Schematic diagram of Command equipment

REDACTED

337 A description and full operating procedures for the equipment is contained Integrated Electronic Technical Publication (IETP) TBA.

FIRE ALARM SYSTEM

338 The fire warning system fitted to this vehicle is electronically controlled and is automatic in operation.

339 When fire or overheating is detected, a warning system is energized, consisting of two flashing warning lights and a horn. A further audio alarm is also sounded through the crew headsets.

340 The major units comprise a firewire control box, a warning light unit, a fire warning light, a warning horn and a sensing element loop.

341 Test facilities are provided to enable the correct functioning of the equipment to be checked.

Firewire control box No. 1, Mk 1

342 The firewire control box is located on the RH wall of the driver's compartment. For a technical description, see EMER Power P 452/4.

Warning light unit No. 3, Mk 1

343 The warning light unit (Fig 51) is located in the centre of the hull forward bulkhead. It is of pre-fabricated metal box construction, waterproofed and fitted with a cover and a 'Gatex' mounting provided with four fixing bushes (4). The cover is secured by four captive cheese-headed screws and lock washers. These are locked with wire and a lead seal. A waterproof test plug (7) is provided.

344 The box houses a flasher unit and a warning lamp, electrical connection is made via an AN plug (6).

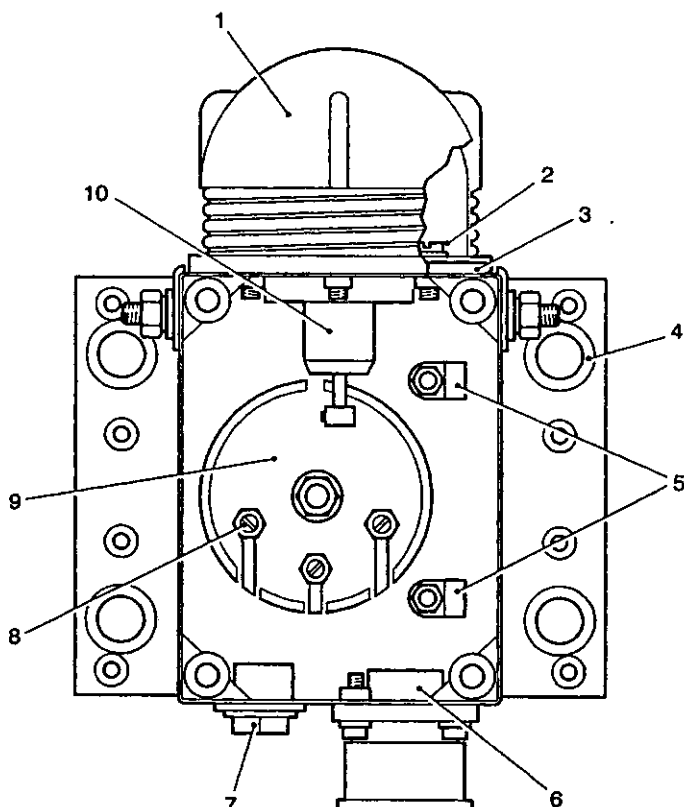

432/453

- | | | | |
|---|--------|----|---------------|
| 1 | Lens | 6 | Plug |
| 2 | Screw | 7 | Test plug |
| 3 | Gasket | 8 | Terminal post |
| 4 | Bushes | 9 | Flasher unit |
| 5 | Clips | 10 | Lamp holder |

Fig 51 Warning light unit

345 The flasher unit (9) consists of a hollow circular base fitted with a cover and housing two bi-metallic indirectly heated strips protected by a fibre disc.

346 Each bi-metallic strip carries a heating element and is fitted to a terminal post (8) at one end to a contact at the other. The strips are arranged so that the contacts are one above the other and are normally open (NO).

347 Three terminal posts extend through the base identified A, B, L, respectively and are protected by the cover.

348 The heater elements are connected in series to terminals A, B. one bi-metallic strip is connected to terminal A and the other to terminal L.

349 Operation of the relay in the firewire control box causes current to flow through the heating elements. The bi-metallic strips are heated and bend towards each other until the contacts make to complete the circuit to the warning lights and short circuit the heating element. The strips cool down and bend away from each other to break the light circuit and re-introduce the heating elements. The cycle is repeated until the relay in the firewire control box is de-energized.

350 The warning lamp located at the top of the box consists of a metal base, a metal cased lamp holder (10) with a 24W SCC lamp and lens (1).

351 The base is secured by three cheese-headed screws (2); it is in the form of a shallow cup threaded to accommodate the lens.

352 Between the base and the box is fitted a gasket (3).

353 A single contact lamp holder is secured to the base by three cheese-headed screws.

354 Red glass lens is used, it is optically formed on the inside to give the desired light spread and has a thread on its periphery and four webs on its outside face to facilitate screwing in and out of the base.

355 Provision is made to enable a grille to be fitted for protection of the lens.

Warning light No. 3, Mk 3

356 A warning light, located in the driving compartment on the front fascia, is similar to the vehicle sidelights, except that red lens are fitted and no waterproofing is provided, a 6W lamp filament is fitted.

Horn No. 2, Mk 1

357 The warning horn is located in the driving compartment and operates with the warning lights to give audible warning.

358 It is identified 'FIRE ALARM'. It is similar in construction and operation to the traffic horn.

Sensing element (Firewire) loop

359 The sensing element loop consists of six elements. In this installation, four elements with two flexible couplings are used in the power pack, one element across the ventilation fan cowls and one in the steering unit. They are connected to make one continuous loop by means of angled couplings and termination couplings. The elements are retained in position by quick-release clips (Fig 52 (6) and rubber sleeves (7).

360 The element (5) consists of a stainless steel capillary tube containing temperature sensitive filling material and a co-axially located wire.

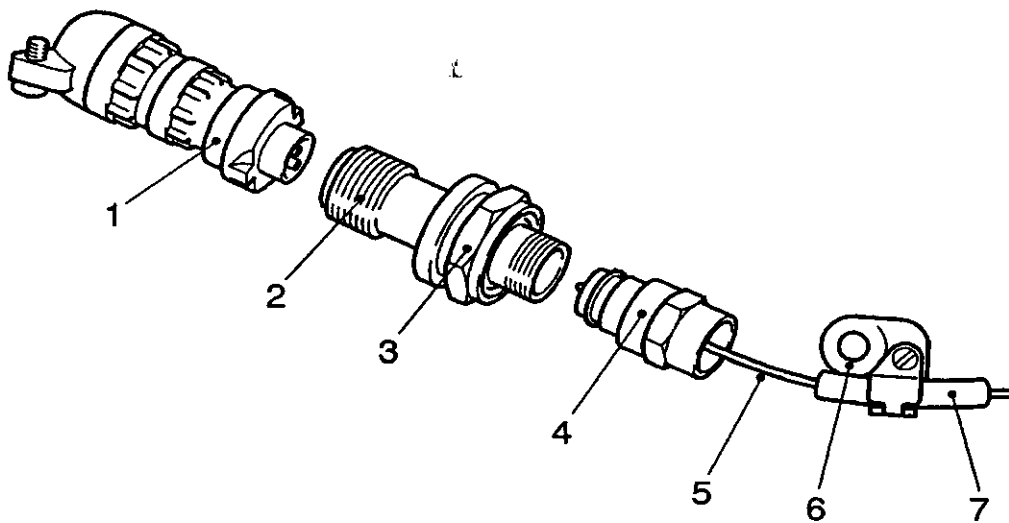

- 1 Two-pin socket
- 2 Cranked barrel
- 3 Nut
- 4 Coupling

- 5 Element
- 6 Clip
- 7 Sleeve

432/201

Fig 52 Firewire element and termination coupling

361 Each element end fitting comprises a centre pin (Fig 53(3)), housed in, but insulated from, the coupling body (5). The body is stepped and is provided with a cone seating on the extremity of the inner step. It is also recessed to house a sealing ring (4). A copper washer (6) serves as a skid ring to prevent the coupling turning on the element. The sealing ring and cone seating form a seal against the ingress of moisture.

362 Each flexible coupling consists of a casing of circular steel bellows having a close braided sheath of the same metal. The co-axial conductor is supported within the casing by ceramic beads, fitted to each end are sealed union and coupling nuts. It is designed for the connection of sensing elements between systems where exceptional vibration is expected.

363 The element couplings (Fig 53) comprise a tube with a thread and cone seating at each end to receive an element coupling nut. A centre socket insulated from the tube connects with the centre pin of the element and fitting. Provision is made for tightening the coupling by a hexagon on the tube.

364 Each end of the element loop is fitted to a termination coupling located on a bracket in the power pack terminal board. The coupling comprises a flanged, cranked barrel (Fig 52(2)) housing an insulated central socket connector at one end and a two pin socket at the other. The middle of the coupling is 'D' shaped and fitted with a tab washer and is secured to the panel by means of a hexagon nut (3). The centre electrode of the element via the end coupling is connected to pin A of the two-pin socket (1), pin B is connected to earth.

365 The couplings are initially provided with protection caps to prevent any ingress of moisture, dirt, etc, and must be refitted when a coupling is not in use on an installation, i.e., disconnected or removed.

366 The sensing element depends for its operation on the ability of the temperature sensitive filling material to store an electrical charge when heated. It is an averaging device, the amount of charge stored varying with the length of the element exposed to the source of heat, i.e., a small length subjected to a high degree temperature source would produce a sufficient charge to operate the system as would a longer length subjected to a lower degree temperature source.

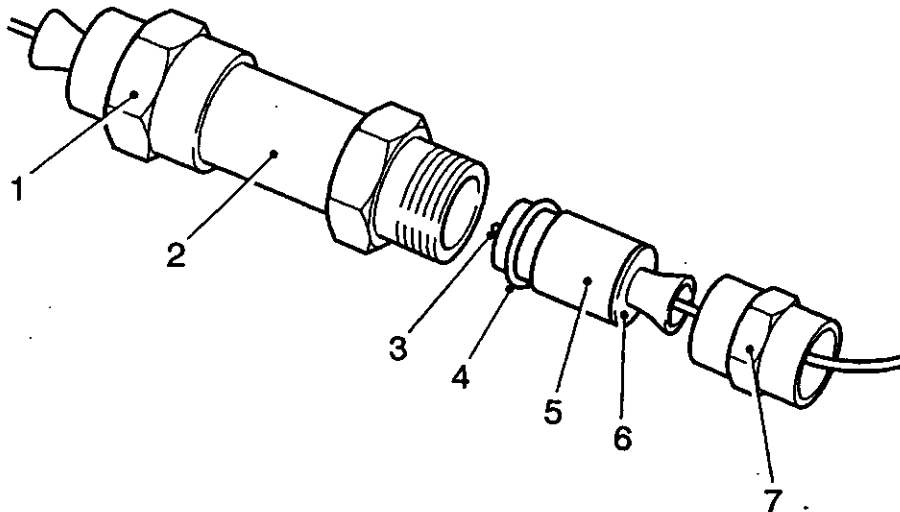

432/454

1	Nut	5	Coupling body
2	Cranked barrel	6	Washer
3	Centre pin	7	Nut
4	Sealing ring		

Fig 53 Firewire coupling

Operation

367 The electrical operation of the fire fighting system is divided into three sections, Oscillator, Firewire hot and cold and Testing.

368 The a.c. supply to the Firewire detecting elements is generated by a relaxation Oscillator consisting of two transistors VT1 and VT2, a toroidal transformer T1 and a bias resistor R1. The transistor may be regarded as switches that alternately connect the d.c. supply to each half of the transformer primary winding. With the battery switch 'ON', both transistors conduct, causing current to flow through each half of the feedback winding, the currents being opposite polarity to each other due to the centre tapped negative return; the EMF's induced in the windings will also have opposite polarity. Thus, the base emitter junction of one transistor will be biased to cut-off, the other will be biased to conduct across its collector emitter junction and almost the full supply voltage is applied across the relevant half primary winding. The primary current rises linearly until the transformer core begins to saturate. The primary inductance then falls and the rate of change of current increase rapidly until the current reaches a maximum value determined by the base current available from the feedback winding and the current gain of the transistor. The rate of change of flux in the core becomes zero and the feedback voltage and the collector current tend to cease.

369 As the collector current falls to zero, flux is produced in the core in the opposite direction and the other transistor is now biased to conduction by the voltage induced in its feedback winding, the first transistor now being biased to cut-off the flux reversal. The cut-off transistor is further cut-off by the reverse bias applied at its base.

370 The cycle is repetitive and the voltages developed across the secondaries of the transformer are of square waveform.

371 Diode MR2 is incorporated to prevent the unit functioning in the event of reversed polarity of the d.c. supply. Diode MR1 is a Zener diode and in conjunction with resistor R7 forms potential divider network to stabilize the input supply voltage.

Firewire hot

372 During a cycle of a.c. output from the transformer, the positive half-cycle is used as the charging period for the detection system.

373 In the charging period, winding A and C are positive with respect to B and the diode MR3 is free to conduct. The sensitive element being hot, is able to accept energy, this is supplied from winding A and B via MR3 and R2 and discharges via R4 and L1 to a.c. is high, thus the larger part of the charge is derived from winding A and B.

374 As this is the positive half of a cycle, a negative potential will appear across R4, since the current flow is from C to B, i.e., in a clockwise direction. This voltage and a negative bias due to the circuit MR4, R5 and C2 tends to prevent the silicon controlled rectifier from triggering under the charge condition.

375 In the discharging condition A and C are negative with respect to B and the sensing element is free to discharge. The blocking action of the diode MR3 prevents discharge to A, it therefore discharges through L1 and R4 and is assisted in this due to C now being negative. The charge on the sensing element will have a d.c. characteristic, i.e., unidirectional. The inductance L1 will appear as low impedance to the charge. The sensing element will thus discharge via L1 and a voltage will appear across R4. As stated, the ability of the sensing element to store a charge is dependant upon temperature; therefore, the voltage appearing across R4 is dependant upon temperature.

376 When the temperature and therefore the charge of the sensing element rises, sufficient voltage appears across R4 to overcome the bias developed by MR4, R5 and C2, and to 'trigger' the silicon controlled rectifier MR7 (SCR). The SCR impedance drops to a low value and a current flows from winding C and D of the transformer through the diode MR5 and operates Relay RLA. Contacts RLA1, 2, 3 and 4 now close. RLA1 contacts short circuit R2 and allows a larger charging voltage to become available, this provides a positive 'lock-on' signal to prevent relay chatter and a positive differential between operate and reset temperatures. The closing of contacts RLA4 completes a 24V d.c. supply to operate the warning horn. Contacts RLA3 complete a separate supply from the battery master switch via the flasher unit to the warning lights

377 As the fire is brought under control, the temperature of the FIREWIRE element drops, thus the charge on the element decreases until insufficient discharge occurs via L1 and R4 to maintain SCR in the conducting state. The SCR cuts off and the Relay RLA is de-energized to shut off the system.

378 In the event of a complete short circuit on the FIREWIRE element, there can be no charge or discharge due to the capacity of the FIREWIRE being short circuited also, therefore, the system will not give a false warning.

Firewire cold

379 When the FIREWIRE is cold, the impedance between sheath and centre conductor is high and the ability to accept a charge will be low. Therefore, sufficient charge cannot build up to produce a voltage drop across R4 and the SCR will not be triggered.

Testing

380 Interposing capacitor C1 in series with the FIREWIRE centre conductor, i.e., in parallel with the element insulation, to simulate the FIREWIRE element resistance charge when hot, tests the system.

381 With the switch in the FIREWIRE control box set to TEST position, the charge from C1 and the FIREWIRE will enable Relay RLA to be energized as would occur in the event of a fire. Contacts RLA1, 2, 3 and 4 are closed, the warning circuits energized, i.e. horn and warning lights, showing serviceability of the warning system.

382 Should the interior of the couplings of the FIREWIRE sensing element loop become contaminated with moisture, dirt, etc, corrosion may be set up that may generate a voltage due to electrolytic action. Under this condition, when the system is tested, relay RLA will remain energized when the TEST switch is returned to normal. The warning lights and horn will continue to function. In addition, if the insulation resistance across the FIREWIRE loop drops to the range of 300-1, 600 ohms, the same test condition will be given when the TEST switch is pressed.

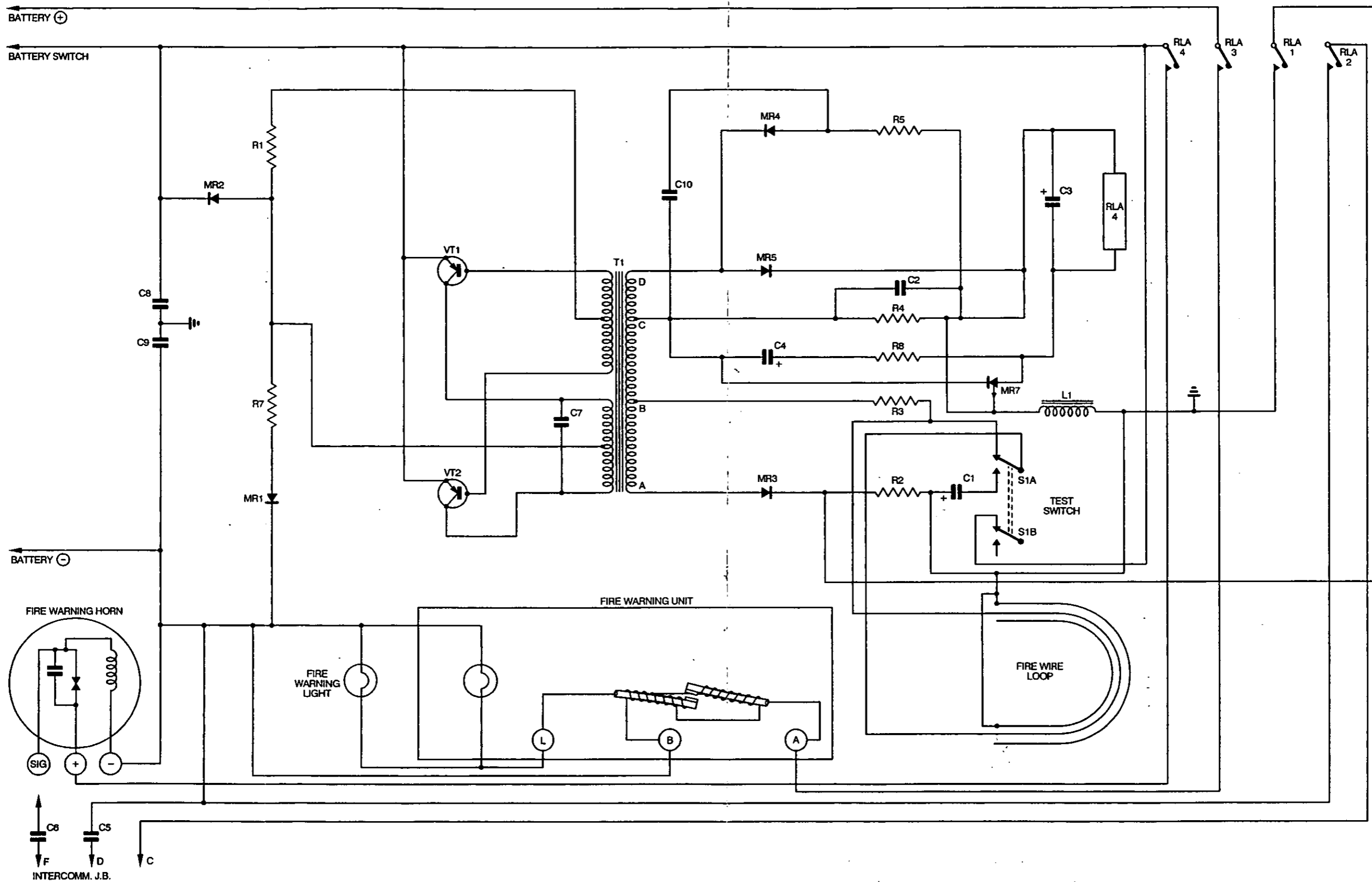

Fig 54 Fire warning wiring diagram

PUMP, FUEL PRESSURIZING, NO 2, MK 1

383 The fuel pump is flange mounted on the collector tank located below the floor plates; see Cat 201 Chapter 2-2, Fig 25. It is controlled by the engine switch in the driver's compartment and protected by a 15A circuit breaker in the distribution panel No 6, Mk 1 or fuse C (15 amp) if distribution panel No 5, Mk 1 is fitted. Designed for use with multi-fuel engines, it delivers fuel from the fuel tanks, under pressure, and is regulated by a relief valve situated in the power pack.

384 The unit (Fig 55) consists of two main assemblies, an electric motor located within a bell housing (6) and a transfer pump housed within a flange body (12), the lower half of the motor yoke extends into the flanged body.

385 To prevent egress of fuel from the pump to the motor, two oil seals (13) and a lubrication bush (3) are fitted between the motor and the pump.

386 The rotation is clockwise, viewed from the pump end.

387 The motor, mounted external to the tank, is completely enclosed, dust and waterproofed and is a four pole (5) series wound two brush (7) machine, with a wave wound armature (11); capacitors (10) and chokes (9) located in the CE shield suppress radio interference. The chokes are connected in series with the field coil and brushes, the capacitors between chokes and earth. A three pin socket (8), located on the CE shield, provide for electrical connection, pins A and B are used.

388 The transfer pump, with its inlet (16) immersed in fuel, comprises an eccentric liner (2), two U shaped blades (15) and a rotor (1).

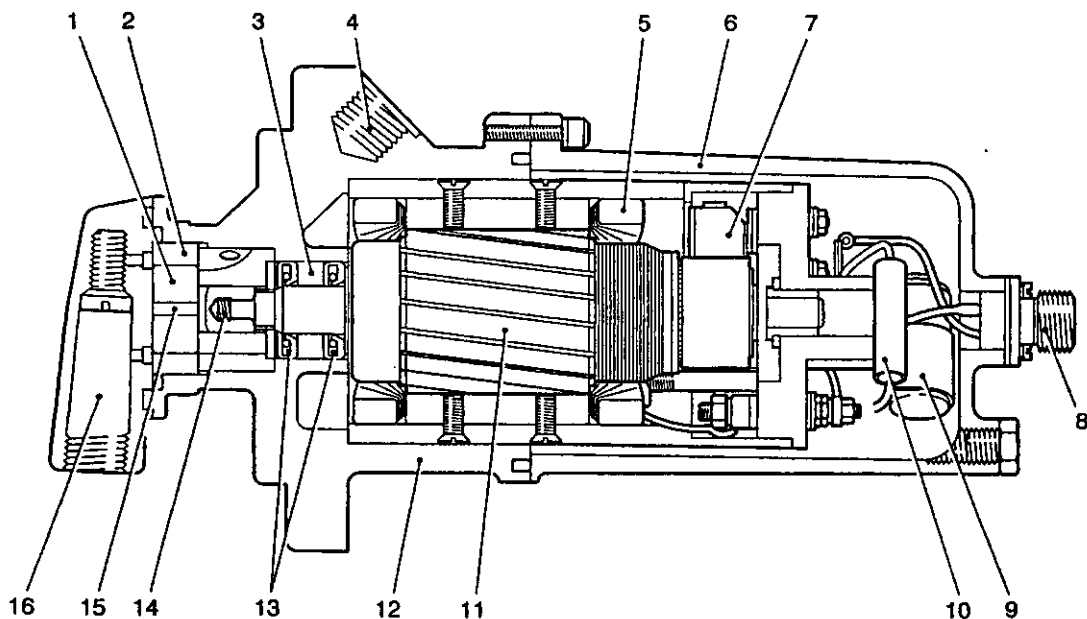

432/376

1	Rotor	5	Field coil	9	Choke	13	Oil seal
2	Liner	6	Bell housing	10	Capacitor	14	Spring
3	Bush	7	Brush	11	Armature	15	Blade
4	Outlet	8	Socket	12	Flange body	16	Inlet

Fig 55 Pump, fuel pressurizing, No 2, Mk 1

389 The rotor has two slots at one end in which the blades fit and are free to slide, with a slot at the other to accommodate a tongue on the armature shaft.

390 The two blades revolve within the liner driven by the rotor. During one revolution of the rotor, with the blades following the contour of the liner, in the extended position, a volume of fuel is collected and when the blade position is restricted due to the eccentricity of the liner, the fuel is compressed and expelled under pressure to the outlet. The outlet pressure is set by the eccentricity of the liner.

391 A spring (14) is inserted between the armature shaft and recess in the pump rotor to take up armature end float.

NOTE

The pump must never be run in a dry condition, this will adversely affect the efficiency of moving parts.

Fuel cut-off solenoid CAV type 236A-46

392 The fuel cut-off solenoid (Fig 56) is similar to the fuel cut-off solenoid described in EMER Power S 532/1 with the following differences.

393 The unit has four studs (2) and is flange mounted to the fuel injection pump. The solenoid has a 24V coil (3) and is operated by the engine switch in the driver's compartment. The solenoid core (7) is directly connected to a control rod (1) and in the energized position is spring-loaded, this is a fail-safe device, the control rod returning to the stop fuel position in the event of an electrical failure or the engine switch turned to stop position.

394 The solenoid core and control rod are free to move laterally, the length of movement of the core in the solenoid sleeve is determined by a groove in the core in which a pin (9) is located. The pin is retained by a hexagon headed dowel screw (8).

395 The solenoid cover (6) is mounted on two studs, is secured by two dome nuts (5); a sealing ring (4) located in a groove in the cover prevents the ingress of oil and dirt.

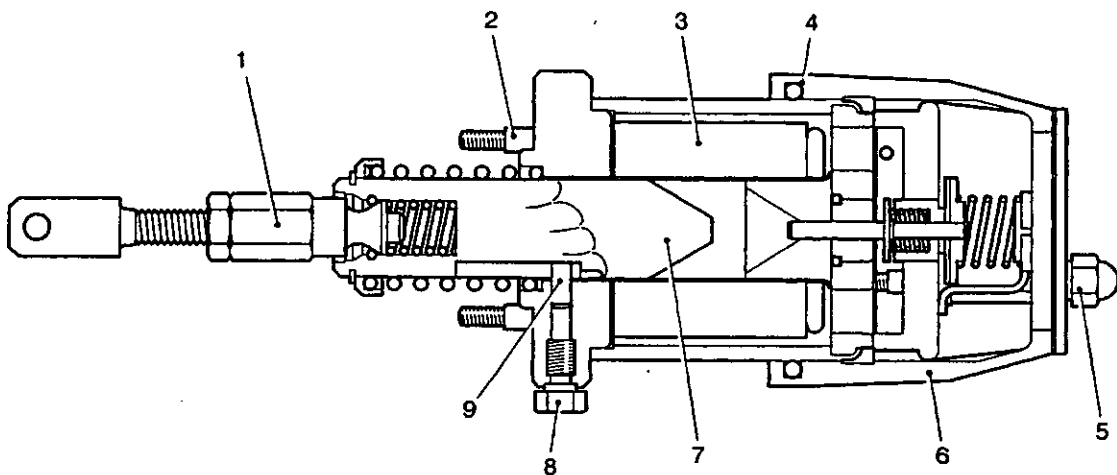

432/389

1	Control rod	4	Sealing ring	7	Core
2	Studs	5	Nut	8	Screw
3	Coil	6	Cover	9	Pin

Fig 56 Fuel cut-off solenoid

COMMENT(S) ON AESP*

To: DCCS
BFPO 794

From:
.....
.....
.....

Sender's Reference	BIN Number	Date
AESP* Title:		
Chapter(s)/Instruction	Page(s)/Paragraph(s)	
If you require more space please use the reverse of this form or a separate piece of paper. Comment(s):		

Signed: Telephone No.:
Name (Capitals): Rank/Grade: Date:
X

FOR AESP* SPONSOR USE ONLY

To: From:
.....
.....
.....

Thank you for commenting on AESP*:
Your reference: Dated:

Action is being taken to:	Tick		Tick
Issue a revised/amended AESP*		Under investigation	
Incorporate comment(s) in future amendments		No action required	
Remarks			

Signed: Telephone No.:
Name (Capitals): Rank/Grade: Date:
*AESP or EMER

UNRESTRICTED

UNRESTRICTED

UK RESTRICTED

UK RESTRICTED

SERVICE DRAWING
 FV 2051978
 SECURITY CLASSIFICATION
RESTRICTED
 DRAWN ON 3rd ANGLE PROJECTION

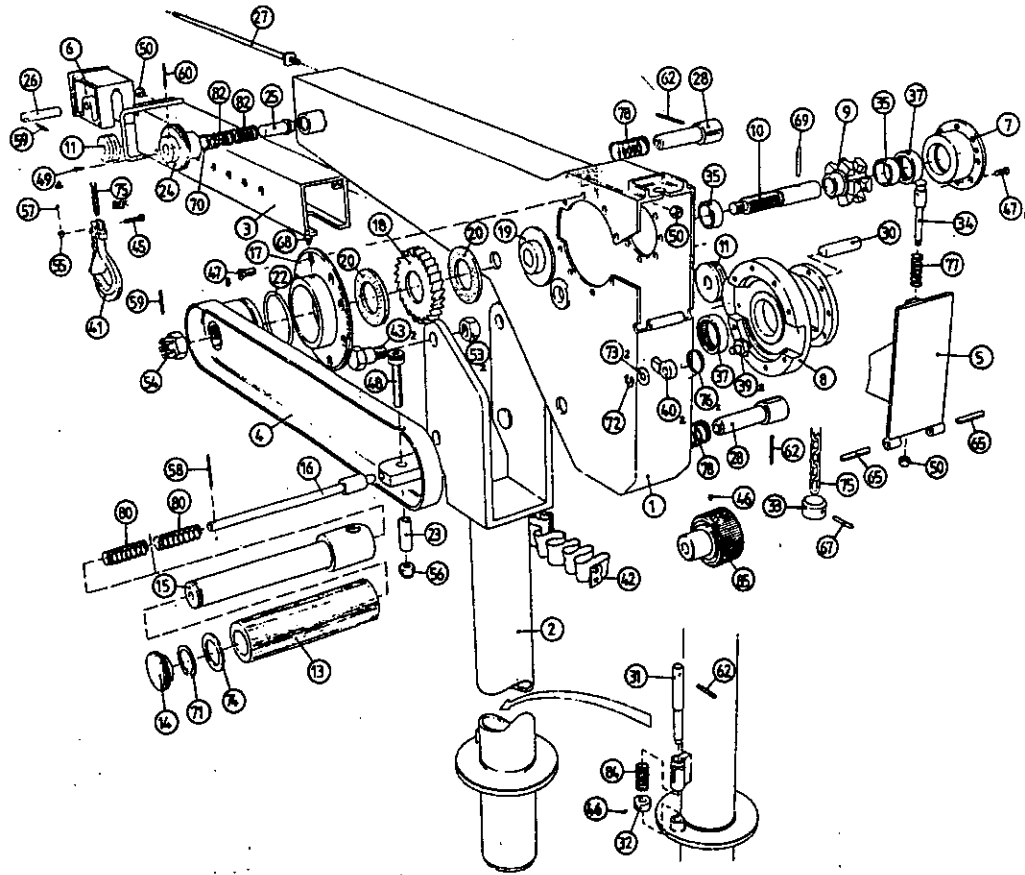

DRAWN			
TRACED			
CHECKED			
DATE	13-3-78		
BY			
DATE	23-3-78		

Drawn in accordance with DARS drawing standards to be used as a reference only. All dimensions, tolerances, and materials shall be as specified in the drawing. All internal surfaces shall be finished to the standard specified in the drawing unless otherwise stated. All dimensions shall be in inches unless otherwise stated. All dimensions shall be to the original scale of the drawing. Do not use to scale drawings.

MATERIAL
 FINISH
 TEST MASS

SCALE - NTS
 TOLERANCES
 UNLESS OTHERWISE STATED
 DIMENSIONS IN
 INCHES
 TEST MASS

OUTLINE DRAWING OF
AFV HOIST
 DARS NO 2500-29-29-3574
 CONTRACTOR
POLYTRONICS CORPORATION
 MOD (PE) 0600A

RESPONSIBLE AUTHORITY
 MOD (PE) 0600E
 SECURITY CLASSIFICATION
RESTRICTED
 CONTRACTORS O&S NO
 SERVICE DRAWING NO
FV 2051978

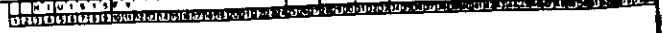

1	SECURITY CLASSIFICATION										
2	RESTRICTED										
3	USED ON										
4	FV										
5	2052080										
6	2072401										
7	To										
8	2072425										
9	INCLUSIVE										
10	2135552										
11	2136306										
12	To										
13	2136311										
14											
15											
16											
17											
18											
19											
20											
21											
22											
23											
24											
25	DRG. LIST										
26	FV										
27	2051978										
28											
29											
30											
31											
32											
33											
34											
35											
36											
37											
38											
39											
40											
41											
42											
43											
44											
45											
46											
47											
48											
49											
50											
51											
52											
78											
79											
80											

ITEM	IDENTIFICATION DRAWING No.	TITLE / N.S.N.	QTY OFF	REMARKS
1		MAIN JIB.	1	RBL21-001
2		PILLAR.	1	RBL21-002
3		INNER JIB.	1	RBL21-003
4		HANDLE ARM.	1	RBL21-004
5	2590-99-111-2958	DOOR, ACCESS.	1	RBL21-005
6	2590-99-862-8404	HOLDSING, WHEEL, JIB END.	1	RBL21-006
7	3130-99-304-1381	CAP, BEARING OUTER.	1	RBL21-007
8	2590-99-235-7326	HOLDSING, CHAIN DRIVE.	1	RBL21-008
9	3020-99-700-8685	SPROCKET, CHAIN DRIVE.	1	RBL21-009
10	3040-99-452-5772	SHAFT.	1	RBL21-010
11	3020-99-513-4011	GUIDE WHEEL, CHAIN.	2	RBL21-011
12				
13		HAND GRIP.	1	RBL21-012
14	5355-99-051-2987	KNOB, FOLDING HANDLE.	1	RBL21-013
15		HAND GRIP SHAFT.	1	RBL21-014
16	5315-99-108-4962	PIN, LOCKING.	1	RBL21-015
17	2590-99-751-3941	FLANGE, SUPPORT.	1	RBL21-016
18	3020-99-215-1030	RATCHET WHEEL.	1	RBL21-017
19	5310-99-124-7034	NUT.	1	RBL21-018
20	5310-99-869-0030	WASHER, FIBRE.	2	RBL21-019
21				
22	5330-99-605-2748	RING, SEALING, TOROIDAL.	1	RBL21-020

1	13-39	A2912									
ISS.	DATE	CHANGE No.	ISS.	DATE	CHANGE No.	ISS.	DATE	CHANGE No.	ISS.	DATE	CHANGE No.
CERT'D			TITLE				RESPONSIBLE AUTHORITY				
wamell			OUTLINE DRAWING OF AFV HOIST				MOD (PE) DGFVE				
DATE			N.S.N. 2590-99-251-9574				SECURITY CLASSIFICATION				
3-4-91							RESTRICTED				
CHECKED			HUNTING COMMUNICATION TECHNOLOGY LTD.				CONTRACTORS DRG. No.				
A.W.ELY			MOD. ESTABLISHMENT				ITEM LIST FOR				
			MOD (PE) DGD QA				FV2051978				
							SHEET No. 1 OF 4				

SECURITY CLASSIFICATION													
RESTRICTED													
USED ON		ITEM	IDENTIFICATION DRAWING No.	TITLE / N.S.N.				QTY OFF	REMARKS				
3													
4													
5		23	3120-99-441-3274	BUSH.				1	RBL 21-021				
6		24	5355-99-192-1996	KNOB, INNER JIB.				1	RBL 21-022				
7		25	5310-99-537-9628	PIN INNER JIB.				1	RBL 21-023				
8		26	3040-99-776-2783	SPINDLE.				1	RBL 21-024				
9		27	5307-99-020-6187	STOP ROD.				1	RBL 21-025				
10		28	5315-99-850-3547	PIN, JIB LOCKING.				1	RBL 21-026				
11		29											
12		30	3040-99-501-1196	SPINDLE.				1	RBL 21-027				
13		31	5315-99-452-4638	PIN, LOCKING.				1	RBL 21-028				
14		32	3040-99-300-1807	COLLAR.				1	RBL 21-029				
15		33	2590-99-746-2784	CHAIN STOP.				1	RBL 21-030				
16		34	5315-99-888-3130	PIN, LATCH.				1	RBL 21-031				
17		35	3110-99-030-9075	BEARING.				2	RBL 21-032				
18		36											
19		37	3110-99-863-5625	BEARING, NEEDLE.				2	RBL 21-033				
20		38											
21		39	2590-99-008-0222	POST. RATCHET PAWL.				2	RBL 21-034				
22		40	3040-99-657-6806	PAWL.				2	RBL 21-035				
23		41	4030-99-005-0241	HOOK.				1	RBL 21-036				
24		42	5340-99-051-2988	STRAP.				1	RBL 21-037				
25		43	5306-99-143-2135	BOLT, PINOT.				2	RBL 21-038				
26		44											
27													
28													
29													
30													
31													
32													
33													
34													
35													
36													
37													
38													
39													
40													
41													
42													
43													
44													
45		1	13-3-91	A2912									
46		ISS.	DATE	CHANGE No.	ISS.	DATE	CHANGE No.	ISS.	DATE	CHANGE No.	ISS.	DATE	CHANGE No.
47		CERT'D	TITLE				RESPONSIBLE AUTHORITY						
48		<i>W. J. W. J.</i>	OUTLINE DRAWING OF AFV				MOD (PE) DGFVE						
49		DATE	HOIST				SECURITY CLASSIFICATION						
50		3-4-91					RESTRICTED						
51			N.S.N.				CONTRACTORS DRG. No.						
52		CHECKED					HUNTING COMMUNICATION TECHNOLOGY LTD.						
53													
54		DRAWN	MOD. ESTABLISHMENT				ITEM LIST FOR				SHEET No. 2 OF 4		
55		A.W. ELY	MOD (PE) DGDQA				FV 2051978						

SECURITY CLASSIFICATION											
RESTRICTED											
USED ON		ITEM	IDENTIFICATION DRAWING No.	TITLE / N.S.N.				QTY OFF	REMARKS		
1											
2											
3											
4											
5		45	5306-99-143-2135	BOLT				1	RBL21-039		
6		46	5305-99-122-5484	SCREW GRUB M4x6 CLIP POINT SKT DRIVE				2	FINISH BLUE/BLACK		
7		47	5305-99-122-5320	SCREW, SKT HD CSK M6x16 OXIDISED BLACK				16			
8		48	5305-99-130-0323	SCREW, SKT HD FILLISTER M8x35 OXIDISED BLACK				1			
9		49	5305-99-122-5312	SCREW, SKT HD CSK M4x12 OXIDISED BLACK				4			
10		50	5310-99-122-5495	NUT, SELF-LOCKING HEX M6 ZINC PLATED				3			
11		51									
12		52									
13		53	5310-99-977-3758	NUT, SELF-LOCKING HEX M14x2 ZINC PLATED				2			
14		54	5310-99-192-2019	NUT, CASTELLATED HEX M14x2 ZINC PLATED				1			
15		55	5310-99-313-3766	NLT				1	RBL21-040		
16		56	5310-99-122-5496	NUT SELF-LOCKING HEX M8 ZINC PLATED				1			
17		57	5315-99-851-7952	PIN.				1	RBL21-041		
18		58	5315-99-400-0548	PIN, SPRING.				1	RBL21-042		
19		59	5315-99-440-2966	PIN, SPRING.				2	RBL21-043		
20		60	5315-99-870-6254	PIN, SPRING.				1	RBL21-044		
21		61									
22		62	5315-99-611-3648	PIN, SPRING				3	RBL21-045		
23		63									
24		64									
25		65	5315-99-362-6750	PIN, SPRING				2	RBL21-046		
26		66									
27											
28											
29											
30											
31											
32											
33											
34											
35											
36											
37											
38											
39											
40											
41											
42											
43											
44											
45											
46											
47											
48											
49											
50											
51											
52											
53											
54											
55											
56											
57											
58											
59											
60											
61											
62											
63											
64											
65											
66											
67											
68											
69											
70											
71											
72											
73											
74											
75											
76											
77											
78											
79											
80											

DRG. LIST											
1	13-3-91	A2912									
ISS.	DATE	CHANGE No.	ISS.	DATE	CHANGE No.	ISS.	DATE	CHANGE No.	ISS.	DATE	CHANGE No.
CERT'D		TITLE				RESPONSIBLE AUTHORITY					
<i>submaner</i>		OUTLINE DRAWING OF AFV HOIST				MOD (PE) DGFVE					
DATE		N.S.N.				SECURITY CLASSIFICATION					
3-4-91						RESTRICTED					
CHECKED		HUNTING COMMUNICATION TECHNOLOGY LTD.				CONTRACTORS DRG. No.					
<i>[Signature]</i>											
DRAWN		MOD. ESTABLISHMENT				ITEM LIST FOR				SHEET	
A.W. ELY		MOD (PE) DGDQA				FV2051978				No. 3	
										OF	
										A	
										4	

1	SECURITY CLASSIFICATION									
2	RESTRICTED									
3	USED ON	ITEM	IDENTIFICATION DRAWING No.	TITLE / N.S.N.			QTY OFF	REMARKS		
4		67	5315-99-108-4989	PIN, SPRING.			1	RBL21-047		
5	6	68	4730-99-846-1695	GREASE NIPPLE.			1	RBL21-048		
7	8	69	5315-99-300-1818	PIN, SHEAR.			1	RBL21-049		
9	10	70	5365-99-753-0932	RING, RETAINING.			1	RBL21-050		
11	12	71	5365-99-513-4023	RING, RETAINING.			1	RBL21-051		
13	14	72	5365-99-462-0467	RING, RETAINING			1	RBL21-052		
15	16	73	5310-99-122-3034	WASHER FLAT FORM B MB ZINC & PASS.			2			
17	18	74	5310-99-305-3182	WASHER, SPECIAL.			1	RBL21-053		
19	20	75	4010-99-251-5538	CHAIN.			1	RBL21-054		
21	22	76	5360-99-700-8702	SPRING, RATCHET.			2	RBL21-055		
23	24	77	5360-99-386-6694	SPRING.			1	RBL21-056		
25	26	78	5360-99-523-0493	SPRING.			2	RBL21-057		
27	28	79								
29	30	80	5360-99-670-3664	SPRING.			2	RBL21-058		
31	32	81								
33	34	82	5360-99-629-9674	SPRING.			2	RBL21-059		
35	36	83								
37	38	84	5360-99-777-5066	SPRING.			1	RBL21-060		
39	40	85	5315-99-036-5072	PIN, JIB LOCKING.			1	RBL21-061		
41	42	86								
43	44									
45	46	1	13-3-91	A2912						
47	48	ISS.	DATE	CHANGE No.	ISS.	DATE	CHANGE No.	ISS.	DATE	CHANGE No.
49	50	CERT'D	TITLE				RESPONSIBLE AUTHORITY			
51	52	<i>awmell</i>	OUTLINE DRAWING OF AFV HOIST				MOD (PE) DGFVE			
53	54	DATE	N.S.N.				SECURITY CLASSIFICATION			
55	56	3-4-91					RESTRICTED			
57	58	CHECKED	CONTRACTORS DRG. No.							
59	60	<i>AW</i>	HUNTING COMMUNICATION TECHNOLOGY LTD.							
61	62	DRAWN	MOD. ESTABLISHMENT				ITEM LIST FOR			
63	64	A.W.ELY	MOD (PE) DGDQA				FV2051978			
65	66						SHEET No. 4 OF 4			

SIS OFF-LINE ENQUIRY SYSTEM Item of Supply database

NCAGE: U3473

STATUS: A TYPE: E Date Amended: 02/07/2004

Name: TECHNIQUE ENGINEERING LTD

Address: GILLMANS INDUSTRIAL ESTATE, NATTS LANE
BILLINGSHURST
RH14 9EZ
UNITED KINGDOM

Tel: 01403 784678

FAX: 01403 784978

E-MAIL: TECHNIQUE2@BTINTERNET.COM

CONDITIONS OF RELEASE

1. This information is released by the UK Government to the recipient Government for Defence purposes only.
2. This information must be accorded the same degree of security protection as that accorded thereto by the UK Government.
3. This information may be disclosed only within the Defence Department of the recipient Government, except as otherwise authorised by Ministry of Defence (Army).
4. This information may be subject to privately owned rights.

THIS DOCUMENT IS THE PROPERTY OF HER BRITANNIC MAJESTY'S GOVERNMENT, and is issued for the information of such persons only as need to know its contents in the course of their official duties. Any person finding this document should hand it into a British forces unit or to a police station for its safe return to the MINISTRY OF DEFENCE, O.MOD Sy, LONDON SW1A 2HB, with particulars of how and where found. THE UNAUTHORISED RETENTION OR DESTRUCTION OF THE DOCUMENT IS AN OFFENCE UNDER THE OFFICIAL SECRETS ACTS OF 1911 - 1939. (When released to persons outside Government service, this document is issued on a personal basis and the recipient to whom it is entrusted in confidence within the provision of the Official Secrets Acts 1911 - 1939, is personally responsible for its safe custody and for seeing that its contents are disclosed only to authorised persons).

CARRIER, ARMoured STAFF VEHICLE (FULL TRACKED) FV 436 (ASV)

TECHNICAL HANDBOOK - DATA SUMMARY

DESCRIPTION

- 1 The basic vehicle is of FV 432 Mk 2 design modified to Armoured Staff Vehicle role by the fitting of equipment racking, cabling and items which are common to all roles of ASV 436.
- 2 The general concept of roleing, re-roleing, configuration and re-configuration, together with vehicle interconnectivity and the principles relevant to the way in which all the facilities can be used are described in Army Equipment Support Publication (AESP) 5800-H-200 Electronic Installations for Staff Users in ASV 436 - System.

CONDITIONS OF RELEASE

1. This information is released by the UK Government to the recipient Government for Defence purposes only.
2. This information must be accorded the same degree of security protection as that accorded thereto by the UK Government.
3. This information may be disclosed only within the Defence Department of the recipient Government, except as otherwise authorised by Ministry of Defence (Army).
4. This information may be subject to privately owned rights.

THIS DOCUMENT IS THE PROPERTY OF HER BRITANNIC MAJESTY'S GOVERNMENT, and is issued for the information of such persons only as need to know its contents in the course of their official duties. Any person finding this document should hand it into a British forces unit or to a police station for its safe return to the MINISTRY OF DEFENCE D.MOD Sy LONDON SW1A 2HB with particulars of how and where found. THE UNAUTHORISED RETENTION OR DESTRUCTION OF THE DOCUMENT IS AN OFFENCE UNDER THE OFFICIAL SECRETS ACTS OF 1911 - 1939. (When released to persons outside Government service, this document is issued on a personal basis and the recipient to whom it is entrusted in confidence within the provision of the Official Secrets Acts 1911 - 1939, is personally responsible for its safe custody and for seeing that its contents are disclosed only to authorised persons).

CARRIER, ARMoured STAFF VEHICLE (FULL TRACKED) FV 436 (ASV)

TECHNICAL HANDBOOK - UNIT REPAIRS

GENERAL

- 1 For details of Unit Repairs to vehicle see EMER Tkd Veh E 103/2.
- 2 Repairs to vehicle installations are covered by Army Equipment Support Publications (AESPs).
- 3 A list of relevant AESPs are contained in publication AESP 5800-H-280-302 Electronic Installations for Staff Users in Carrier Full Tracked - FV 436 - System.

CONDITIONS OF RELEASE

1. This information is released by the UK Government to the recipient Government for Defence purposes only.
2. This information must be accorded the same degree of security protection as that accorded thereto by the UK Government.
3. This information may be disclosed only within the Defence Department of the recipient Government, except as otherwise authorised by Ministry of Defence (Army).
4. This information may be subject to privately owned rights.

THIS DOCUMENT IS THE PROPERTY OF HER BRITANNIC MAJESTY'S GOVERNMENT, and is issued for the information of such persons only as need to know its contents in the course of their official duties. Any person finding this document should hand it into a British forces unit or to a police station for its safe return to the MINISTRY OF DEFENCE D.MOD Sv, LONDON SW1A 2HB with particulars of how and where found. THE UNAUTHORISED RETENTION OR DESTRUCTION OF THE DOCUMENT IS AN OFFENCE UNDER THE OFFICIAL SECRETS ACTS OF 1911 - 1939. (When released to persons outside Government service, this document is issued on a personal basis and the recipient to whom it is entrusted in confidence within the provision of the Official Secrets Acts 1911 - 1939, is personally responsible for its safe custody and for seeing that its contents are disclosed only to authorised persons).

CARRIER, ARMoured STAFF VEHICLE (FULL TRACKED) FV 436 (ASV)

TECHNICAL HANDBOOK - FIELD REPAIRS

GENERAL

- 1 For details of Field Repairs to vehicle, see Tkd Veh E 104/2.
- 2 Repairs to vehicle installations are covered by Army Equipment Support Publications (AESPs).
- 3 A list of relevant AESPs is contained in publication AESP 5800-H-280-302 Electrical Installations for Staff Users in Carrier, Full Tracked - FV 436 - System.