

QLIS

CAIRS 15337

LASS

DEFENCE LOGISTICS ORGANISATION
CHOBHAM LANE, CHERTSEY
SURREY KT16 0EE



QLIS

- 1 DEC 2001

DLO Chertsey

CONDITIONS OF RELEASE

- 1 This information is released by the UK Government for Defence purposes only.
- 2 This information must be afforded the same degree of security protection as that afforded to information of an equivalent security marking originated by the recipient Government or as required by the recipient Government's security regulations.
- 3 This information may be disclosed only within the Defence Department of the recipient Government, except as otherwise authorized by the Ministry of Defence (Army).
- 4 This information may be subject to privately owned rights.

CARRIER, INSTALLATION, FULL TRACKED, MKs 2 AND 2/1 (FV439)

GENERAL INSTRUCTIONS AND INDEX

THIS DOCUMENT IS THE PROPERTY OF HER BRITANNIC MAJESTY'S GOVERNMENT, and is issued for the information of such persons only as need to know its contents in the course of their official duties. Any person finding this document should hand it in to a British forces unit or to a police station for its safe return to the MINISTRY OF DEFENCE (Dsy (Pol)), MAIN BUILDING, WHITEHALL, LONDON SW1A 2HB with particulars of how and where found. THE UNAUTHORIZED RETENTION OR DESTRUCTION OF THIS DOCUMENT IS AN OFFENCE UNDER THE OFFICIAL SECRETS ACTS OF 1911-1989. (When released to persons outside Government service, this document is issued on a personal basis and the recipient to whom it is entrusted in confidence, within the provision of the Official Secrets Acts 1911-1989, is personally responsible for its safe custody and for seeing that its contents are disclosed only to authorized persons).

BY COMMAND OF THE DEFENCE COUNCIL

Kevin T. ...

Ministry of Defence
Issued by
DEFENCE LOGISTICS ORGANISATION

AMENDMENT RECORD

Amdt No.	Incorporated By (Signature)	Date
1		
2		
3		
4		
5		
6		
7		
8		
9		
10		
11		
12		
13		
14		
15		
16		
17		
18		
19		
20		
21		
22		
23		
24		
25		
26		
27		
28		
29		
30		
31		

Amdt No.	Incorporated By (Signature)	Date
32		
33		
34		
35		
36		
37		
38		
39		
40		
41		
42		
43		
44		
45		
46		
47		
48		
49		
50		
51		
52		
53		
54		
55		
56		
57		
58		
59		
60		
61		
62		

PREFACE

Sponsor:
DGES(A)
File ref:

Publication Agency:
DLO Chertsey
Project No: 97/41c/217(253)
File ref: Admin 281

INTRODUCTION

- 1 The Publication Agency is responsible for the allocation of instruction numbers.
- 2 All general instructions as issued are to be recorded in manuscript by the recipient on the Numerical General Instruction Index provided. Amendments to individual instructions are to be recorded on the instruction amendment record. All extant instructions and amendments can be found listed in the main AESP index.

NOTE

The Publication Agency is responsible for the preparation and maintenance of the Instruction Index and will advise the Distribution Authority on the issue of completed and subsequent blank index pages necessary.

- 3 Service users should forward any comments on this publication through the channels prescribed in AESP 0100-P-011-013. An AESP Form 10 is provided after the preliminary pages of this publication; it should be photocopied and used for forwarding comments on this AESP to DLO DTS.
- 4 AESPs are issued under Defence Council authority and where AESPs specify action to be taken, the AESP will of itself be sufficient authority for such action and also for the demanding of the necessary stores.

GENERAL INSTRUCTION INDEX

SI: Servicing Instructions STI: Special Technical Instructions

Instr No. (1)	SI/STI No. (2)	Subject (3)	Approval No./Remarks (4)
1		EMER TV E 109/9 Misc Instr No. 1 to No. 5	
2		FRONT HINGE HATCH HINGE REPLACEMENT	43/0/0032
3			
4			
5			
6			
7			
8			
9			
10			
11			
12			

(continued)

GENERAL INSTRUCTION INDEX (continued)

Instr No. (1)	SI/STI No. (2)	Subject (3)	Approval No./Remarks (4)
13			
14			
15			
16			
17			
18			
19			
20			
21			
22			
23			
24			
25			
26			
27			
28			
29			
30			
31			
32			
33			
34			
35			
36			
37			
38			
39			
40			
41			
42			
43			
44			
45			
46			
47			
48			

COMMENT(S) ON AESP*

To: DLO DTS 3.2
Ha-Ha Road
Woolwich
LONDON SE18 4QF

From:
.....
.....
.....

Sender's Reference	BIN Number	Date
AESP Title:		
Chapter(s)/Instruction	Page(s)/Paragraph(s)	
If you require more space, please use the reverse of this form or a separate piece of paper. Comment(s):		

Signed: Telephone No:.....
Name (Capitals): Rank/Grade: Date:
X

DLO DTS 3.2 USE ONLY

To:
.....
.....
.....

From: DLO DTS 3.2
Ha-Ha Road
Woolwich
LONDON SE18 4QF

Thank you for commenting on AESP

Your reference Dated:

Action is being taken to:	Tick	Tick
Issue a revised/amended AESP		Under investigation
Incorporate comment(s) in future amendments		No action required
Remarks		

Signed: Telephone No:.....

Name (Capitals): Rank/Grade: Date:

* AESP or EMER

AESP Form 10 (Issue 4.2 dated Apr 00)

CARRIER, INSTALLATION, FULL TRACKED, MKs 2 AND 2/1 (FV439)

GENERAL INSTRUCTION NO. 1

Sponsor:
DGES(A)

Publication Agency:
DLO Chertsey
Project No: 97/41c/217(253)
File ref: Admin 281

AMENDMENT RECORD

Amdt No.	Incorporated By (Signature)	Date
1		
2		
3		

Amdt No.	Incorporated By (Signature)	Date
4		
5		
6		

SUBJECT: EMER TV E109/9 Miscellaneous Instructions No. 1 to No. 5

INTRODUCTION

1

1.1 The EMER decade (TV E100/9 to TV E109/9) that supports the FV439 Series is to be cancelled and replaced by AESP 2350-T-254-octad.

1.2 This AESP General Instruction No. 1 is a complete issue of EMER TV E109/9 Miscellaneous Instructions No. 1 to No. 5 issued under the EMER system.

1.3 Subsequent Miscellaneous Instructions will be issued in AESP format as General Instructions, starting with Gen Instr No. 2.

1.4 Where the EMER TV E109/9 Miscellaneous Instructions refer to an associated EMER TV E100 series publication, this information will be incorporated within the appropriate Miscellaneous Instruction.

1.5 Remove and retain EMER TV E109/9 Miscellaneous Instructions No. 1 to No. 5 from the EMER folder.

1.6 Place this instruction in front of Miscellaneous Instructions removed at Sub-Para 1.5.

1.7 Open a new folder numbered 2350-T-254-821 and titled Carrier, Installation, Full Tracked, Mks 2 and 2/1 (FV439) General Instructions, and place the EMER TV E109/9 Miscellaneous Instructions within.

1.8 Limitations on use of equipment: As detailed within each Miscellaneous Instruction.

APPLICABILITY

2 FV439.

REASON FOR MODIFICATION

3 Code 6 - publications changed from EMER to AESP format.

PRIORITY

4 Routine.

TABLE 1 GENERAL INSTRUCTION INDEX

Instr No. (1)	Issue No. (2)	Pages (3)	Subject (4)	Applicability (5)	Approval No./Remarks (6)
1	1	1	Change of decade title	FV439	
2	1	1-2	Filter anti-vapour (AV) No. 5 Mk 4	FV439	
3	1	1-5	Thermal identity beacon (TIB)	FV439 SAS/MC	
4	1	1-5	Thermal identity beacon (TIB)	FV436 Bates FV436 ASV FV439 ASV	
5	1	1-4	Exhaust extension steady strap		MAE43/9/005

PUBLICATION AMENDMENTS

NOTE

Necessary amendments will be issued separately.

5 Nil.

LT ADM

CONDITIONS OF RELEASE

1. This information is released by the UK Government to the recipient Government for Defence purposes only.
2. This information must be accorded the same degree of security protection as that accorded thereto by the UK Government.
3. This information may be disclosed only within the Defence Department of the recipient Government, except as otherwise authorised by Ministry of Defence (Army).
4. This information may be subject to privately owned rights.

THIS DOCUMENT IS THE PROPERTY OF HER BRITANNIC MAJESTY'S GOVERNMENT, and is issued for the information of such persons only as need to know its contents in the course of their official duties. Any person finding this document should hand it into a British forces unit or to a police station for its safe return to the MINISTRY OF DEFENCE D.MOD Sy LONDON SW1A 2HB with particulars of how and where found. THE UNAUTHORISED RETENTION OR DESTRUCTION OF THE DOCUMENT IS AN OFFENCE UNDER THE OFFICIAL SECRETS ACTS OF 1911 - 1939. (When released to persons outside Government service, this document is issued on a personal basis and the recipient to whom it is entrusted in confidence within the provision of the Official Secrets Acts 1911 - 1939, is personally responsible for its safe custody and for seeing that its contents are disclosed only to authorised persons).

CARRIER, INSTALLATION, FULL TRACKED, FV 439

TECHNICAL HANDBOOK - MISCELLANEOUS INSTRUCTION INDEX

Note ...

This Index is to be kept up to date by the User entering instructions issued under the above designation as and when they are published.

Instr No	Issue No	Pages	Subject	Applicability	Approval No/Remarks
(1)	(2)	(3)	(4)	(5)	(6)
1	1	1	Change of decade title	FV439	Filed preceding Page 1 EDD/9
2	1	1-2	Filter anti-vapour (AV) NoSMK4	FV439	
3	1	1-5	THERMAL IDENTITY BEACON 439 SAS/MC	SAS/MC	
4	1	1-5	THERMAL IDENTITY BEACON	BATES ASV	
5			EXH EXT STRAP		
6					
7					
8					

Instr No	Issue No	Pages	Subject	Applicability	Approval No/Remarks
(1)	(2)	(3)	(4)	(5)	(6)
9					
10					
11					
12					
13					
14					
15					
16					
17					
18					
19					
20					
21					
22					
23					
24					

71312(261)
Vehs & Wpns Br ALM/43900

CONDITIONS OF RELEASE

1. This information is released by the UK Government to the recipient Government for Defence purposes only.
2. This information must be accorded the same degree of security protection as that accorded thereto by the UK Government.
3. This information may be disclosed only within the Defence Department of the recipient Government, except as otherwise authorised by Ministry of Defence (Army).
4. This information may be subject to privately owned rights.

THIS DOCUMENT IS THE PROPERTY OF HER BRITANNIC MAJESTY'S GOVERNMENT, and is issued for the information of such persons only as need to know its contents in the course of their official duties. Any person finding this document should hand it into a British forces unit or to a police station for its safe return to the MINISTRY OF DEFENCE D.MOD Sy LONDON SW1A 2HB with particulars of how and where found. THE UNAUTHORISED RETENTION OR DESTRUCTION OF THE DOCUMENT IS AN OFFENCE UNDER THE OFFICIAL SECRETS ACTS OF 1911 - 1939. (When released to persons outside Government service, this document is issued on a personal basis and the recipient to whom it is entrusted in confidence within the provision of the Official Secrets Acts 1911 - 1939, is personally responsible for its safe custody and for seeing that its contents are disclosed only to authorised persons).

CARRIER, INSTALLATION, FULL TRACKED, MKs 1 AND 2/1 FV 439

TECHNICAL HANDBOOK - MISCELLANEOUS INSTRUCTION

Note...

This page 1/2, is to be filed immediately preceding Page 1 E 100/9-dated May 70.

SUBJECT: Change of decade title

ACTION

1 The above title supersedes the previous titles of the EMER decade E 100/9-E 109/9.

CONDITIONS OF RELEASE

- | | |
|--|--|
| 1. This information is released by the UK Government to the recipient Government for Defence purposes only. | 3. This information may be disclosed only within the Defence Department of the recipient Government, except as otherwise authorized by Ministry of Defence (Army). |
| 2. This information must be accorded the same degree of security protection as that accorded thereto by the UK Government. | 4. This information may be subject to privately owned rights. |

THIS DOCUMENT IS THE PROPERTY OF HER BRITANNIC MAJESTY'S GOVERNMENT, and is issued for the information of such persons only as need to know its contents in the course of their official duties. Any person finding this document should hand it into a British forces unit or to a police station for its safe return to the MINISTRY OF DEFENCE D.MOD Sy LONDON SW1A 2HB with particulars of how and where found. THE UNAUTHORIZED RETENTION OR DESTRUCTION OF THIS DOCUMENT IS AN OFFENCE UNDER THE OFFICIAL SECRETS ACTS OF 1911-1989. (When released to persons outside government service, this document is issued on a personal basis and thereipient to whom it is entrusted in confidence within the provision of the Official Secrets Acts 1911-1989, is personally responsible for its safe custody and for seeing that its contents are disclosed only to authorized persons).

CARRIER, INSTALLATION, FULL TRACKED, MKS 1 AND 2/1 FV 439

TECHNICAL HANDBOOK - MISCELLANEOUS INSTRUCTION

SUBJECT: Filter anti-vapour (AV) No. 5 Mk 4

References:

- A. D/DGES(A)/451/1/2 ES 43a dated 24 Feb 95.
- B. MOD, Chemical & Biological Defence Establishment Ptn/TD500a/PD/551/93 dated 28 Feb 94.

INTRODUCTION

1 This instruction introduces the common peacetime maintenance replacement policy for the stage four collective protection (ColPro) filters.

APPLICABILITY

2 FV 439.

REASON FOR MODIFICATION

3 This instruction reduces the maintenance cost of replacing ColPro filters when there is no operational or nuclear biological chemical (NBC) requirement.

IMPLEMENTATION

4 Action required by:

4.1 Units authorized to carry out levels 1, 2, 3 and 4 maintenance repairs.

ITEMS AFFECTED

5 All Anti-Vapour (AV), filters up to and including No. 5 Mk 4, NSN 9ACR 4240-99-613-9394 (FV.809609).

PRIORITY

6 Immediate.

ESTIMATED TIME REQUIRED

7 1 man-hour.

Stores, tools and equipment

Action required by

8

8.1 Stores to be obtained locally.

Item No.	DMC	NSN/Part No.	Designation	Qty per eqpt
1	33A	8010-99-910-7033	Paint, gloss, brushing signal (Def Stan 80-54)	As reqd

Replacement policy

9 The AV filters are only to be replaced under the following circumstances:

9.1 As directed by MOD, Chemical & Biological Defence Establishment.

9.2 The NBC system fails to function correctly because the filters are blocked or restricted.

9.3 The filters are damaged, corroded or have been soaked in water.

PREPARATION OF FILTERS

10 An examination and test is to be conducted to ensure that the NBC system is fully functional and operates in accordance with the relevant technical and user manuals. An examination is to be made of the filter and fittings, to ensure that:

10.1 The casings are not corroded or damaged.

10.2 All seals and mounting spigots are serviceable.

10.3 The contents do not rattle when shaken.

Detail

11 The NBC system is to be maintained as fully functional in all aspects in accordance with the relevant technical manuals and the following actions are to be carried out:

11.1 The outward face of the anti vapour filters are to be painted signal red using locally obtained paint at Para 8.1.

11.2 An entry is to be made in the AB413 vehicle log book to state the NBC system has been tested and the filters fitted are suitable for **TRAINING USE ONLY**.

11.3 Thereafter filters are only to be changed under the conditions detailed at Para 9.

CONDITIONS OF RELEASE

- | | |
|--|--|
| 1. This information is released by the UK Government to the recipient Government for Defence purposes only. | 3. This information may be disclosed only within the Defence Department of the recipient Government, except as otherwise authorized by Ministry of Defence (Army). |
| 2. This information must be accorded the same degree of security protection as that accorded thereto by the UK Government. | 4. This information may be subject to privately owned rights. |

THIS DOCUMENT IS THE PROPERTY OF HER BRITANNIC MAJESTY'S GOVERNMENT, and is issued for the information of such persons only as needed to know its contents in the course of their official duties. Any person finding this document should hand it into a British forces unit or to a police station for its safe return to the MINISTRY OF DEFENCE D.MOD Sy LONDON SW1A 2HB with particulars how and where found. THE UNAUTHORIZED RETENTION OR DESTRUCTION OF THIS DOCUMENT IS AN OFFENCE UNDER THE OFFICIAL SECRETS ACTS OF 1911-1989. (When released to persons outside government service, this document is issued on a personal basis and the recipient to whom it is entrusted in confidence within the provision of the Official Secrets Acts 1911-1989, is personally responsible for its safe custody and for seeing that its contents are disclosed only to authorized persons).

CARRIER, INSTALLATION, FULL TRACKED,

FV 439, MK 2/1

TECHNICAL HANDBOOK - MISCELLANEOUS INSTRUCTION

SUBJECT: Exhaust extension steady strap.
(MAE 43/9/005)

INTRODUCTION

- 1 This instruction details the fitting of a steady strap to the exhaust extension.

APPLICABILITY

- 2
- 2.1 Fitted to subject vehicles held by user units.
- 2.2 Unmodified stock, held at all levels of technical storage.

REASON FOR MISCELLANEOUS INSTRUCTION

- 3 Code 3 - to improve reliability.

PRIORITY

- 4 Routine.

ESTIMATED TIME REQUIRED

- 5 Embodiment: 0.5 man-hours.

IMPLEMENTATION PLAN

- 6 This instruction is to be implemented by units authorized to carry out levels 2, 3 and 4 maintenance.

Action required by:

7

7.1 Units authorized to carry out levels 2, 3 and 4 maintenance:

7.1.1 When requested by users obtain the items listed in Para 8 and carry out this instruction.

7.1.2 Upon completion, record details of this instruction in equipment documents.

7.2 All recipients of this instruction. Add particulars to EMER Tkd Veh E 109/9 Misc Instr Index.

Stores, tools and equipment

8

8.1 Stores to be demanded.

8.1.1 The following items are to be demanded quoting this instruction as authority for demand.

Item No.	DMC	NSN/Part No.	Designation	Qty per eqpt
1	9ACR	2990-99-169-0706 FV 2200677	Strap exhaust	1

8.2 Stores or suitable equivalent to be obtained locally:

2	G1	5305-99-124-3976	Screw 3/8 in. x 5/8 in. lg UNF	1
3		5309-99-941-0512	Screw 1/4 in. x 1/2 in. lg UNF	2
4		5310-99-915-5148	Washer 3/8 in.	1
5		5310-99-912-8796	Washer 1/4 in.	2
6		5310-99-103-6632	Washer spring 3/8 in.	1
7		5310-99-139-5477	Washer spring 1/4 in.	2

Sequence of operations

9 Carry out the instruction as follows:

9.1 Fit exhaust extension.

9.2 Secure extension with strap (item 1) using screws and washers (item 2 to 7) to side of vehicle as shown in Fig 1.

TESTING AFTER EMBODIMENT

10 Nil.

EFFECT ON WEIGHT

11 Negligible.

PUBLICATION AMENDMENTS

NOTE

Necessary amendments will be issued separately.

12 Nil.

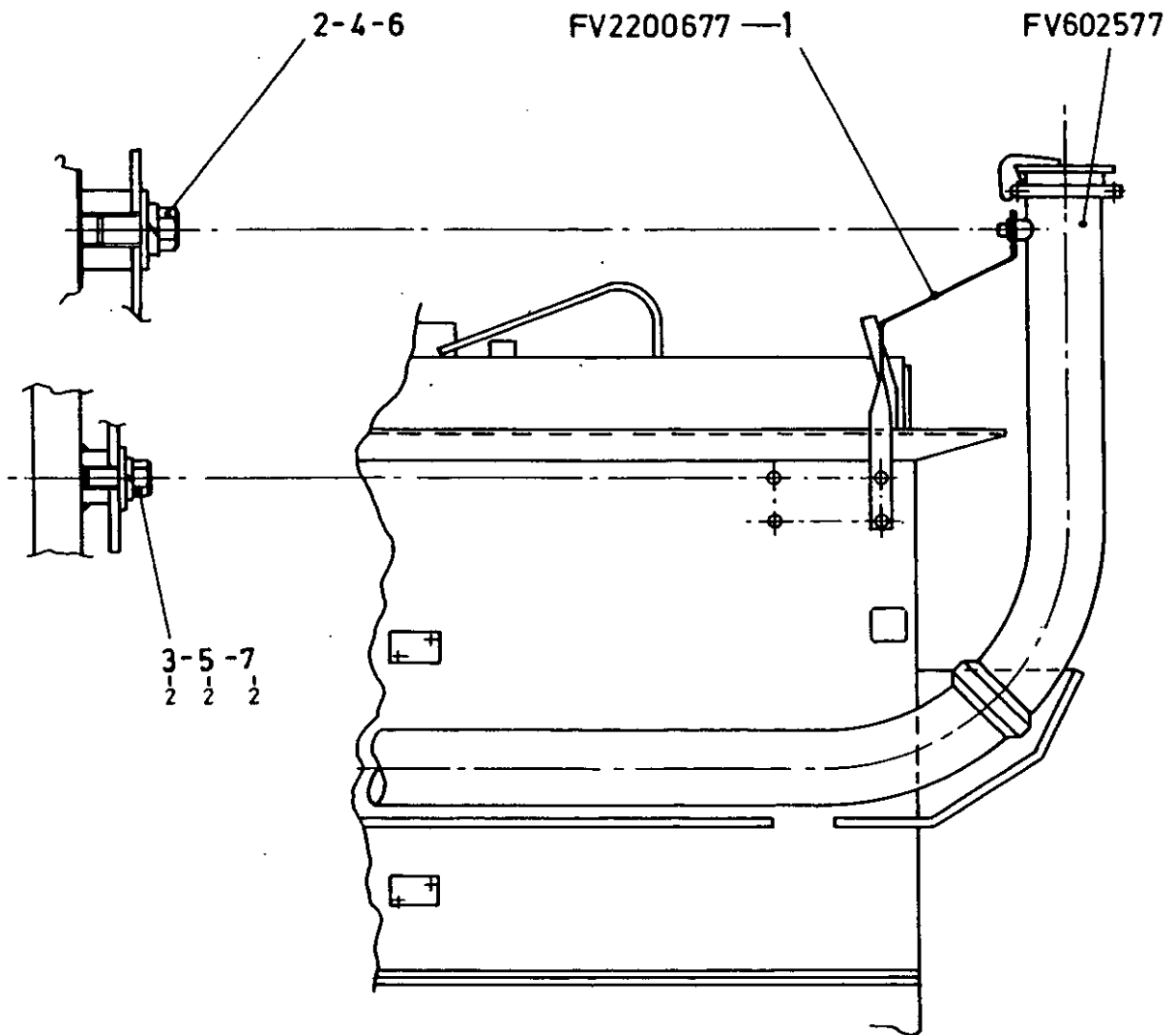

V13951/1

Fig 1 Exhaust strap fitting

CARRIER, INSTALLATION, FULL TRACKED, FV 439 MK 2/1

GENERAL INSTRUCTION NO. 2

Sponsor:
DGES(L)

Publication Agency:
DLO Chertsey
Project No: S01008 (367)
File ref:

AMENDMENT RECORD

Amdt No.	Incorporated By (Signature)	Date
1		
2		
3		

Amdt No.	Incorporated By (Signature)	Date
4		
5		
6		

SUBJECT: Front hatch hinge replacement
(Approval No. 43/0/0032)

INTRODUCTION

- 1 This instruction introduces a method of replacing the front hatch hinges.
 - 1.1 Limitations on use of equipment. Nil.

APPLICABILITY

- 2 All FV 439 vehicles when the front hatch hinges require replacement.
 - 2.1 Unmodified stock, held at all levels of technical storage.

REASON FOR MODIFICATION

- 3 Code 4 – to improve maintainability.

PRIORITY

- 4 Routine.

ESTIMATED TIME REQUIRED

- 5 Embodiment: 2.00 man-hours.

MODIFICATION IMPLEMENTATION PLAN

- 6
 - 6.1 This instruction is to be implemented by Units authorized to carry out levels 3 or 4 maintenance
 - 6.2 Associated instructions. Nil

QLIS
LIASS
17 APR 2001
DLO Chertsey

Action required by

7

7.1 Units and establishments holding equipment:

7.1.1 Examine equipment documents to see if modification is applicable.

7.2 Army units authorized to carry out levels 3 and 4 maintenance:

7.2.1 When requested by units or during overhaul of equipment carry out this modification.

7.2.2 Record completion details of modification against appropriate entry in vehicle documents.

7.3 All recipients of this instruction. Add particulars to AESP 2350-T-254-821 Gen Instr Index.**Stores, tools and equipment**

8

8.1 Stores to be demanded:

8.1.1 The following items are to be demanded, as required, quoting this instruction as the authority.

Item No.	DMC	NSN/Part No.	Designation	Qty per eqpt
1	9ACR	2540-99-874-8857	Hinge, front access cover, hatch half.	2
2	9ACR	2540-99-831-1116	Hinge, front access cover, hull half.	2
3	9ACR	5315-99-804-5525	Pin.	2

Repair schemes**NOTE**

The item numbers of Para 8 are used as reference throughout this instruction.

9 Carry out this instruction, as follows, using items 1, 2 and 3 as required:

9.1 To replace the front access cover hinges (hatch), follow the repair scheme detailed at Fig 1.

or

9.2 To replace the front access cover hinges (hull), follow the repair scheme detailed at Fig 2.

or

9.3 To replace the front access cover hinges (hull and hatch), follow the repair scheme detailed at Fig 3, followed by the repair scheme detailed at Fig 1.

TESTING AFTER EMBODIMENT

10 Check front access hatch to ensure that it opens, closes and seals correctly.

EFFECT ON WEIGHT

11 Negligible.

PUBLICATION AMENDMENTS

NOTE

Necessary amendments will be issued separately.

12 Nil.

NOTES

- (1) This scheme is to be used when hinges on front access cover assembly are replaced.
- (2) Welding is to be carried out to EMER Wksp O 360 Chap 12, using a 3.25 mm rod.
- (3) Before commencing with repair, remove front access cover from the vehicle.

- 1 Remove existing access cover hinges by gas cutting or gouging within 6 mm of armour plate.
- 2 Remove remaining metal by grinding. Avoid overheating of armour plate.
- 3 Finish smooth armour plate and use NDT (penetrant dye) to establish that no surface cracks are present.

NOTE

If cracks are present a separate repair procedure will be required.

- 4 Locate front access cover on vehicle and set to 3.8 mm from inside edge of protection strip and clamp in position.
- 5 Set first front access cover hinge to 1.2 mm from first hull hinge and align hole centres using hinge pin (item 3). Make initial root weld along bottom edge of hinge and cover.
- 6 Set second front access cover hinge to 1.2 mm from second hull hinge and align hole centres using hinge pin (item 3). Make initial root weld along bottom edge of hinge and cover.
- 7 Check accuracy of hinge for position and squareness and use hinge pin (item 3) to ensure clearance when pivoting. See detail 'B'.
- 8 Unclamp front access cover and remove from vehicle.
- 9 Complete welding of front access hinges as shown.
- 10 Inspect.
- 11 After 72 hours, check with NDT that welds and plates are crack free.
- 12 Finish to DEF STAN 03-32 Part 2, colour as per contract.

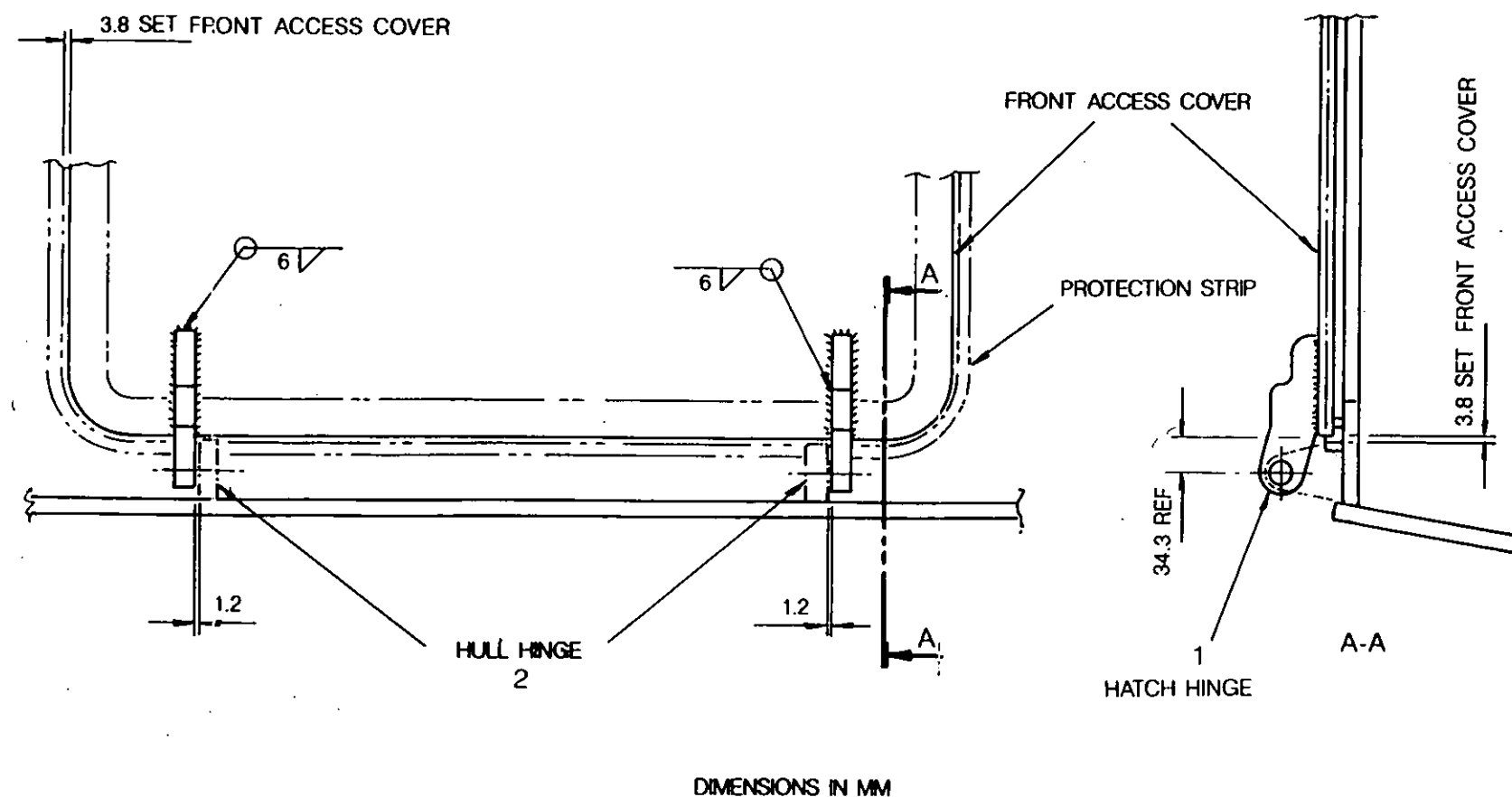
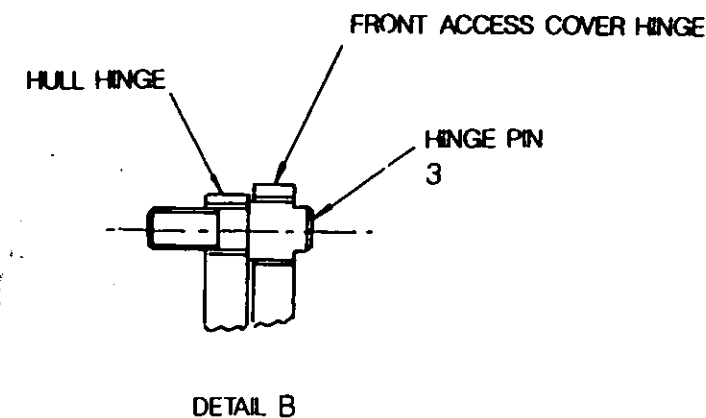

V14677/4

Fig 1 Replacement of the front access cover hinges (hatch), set from the hull hinges

NOTES

(1) This scheme is to be used when only the hinges on the hull are to be replaced. Hull hinge positions are set from existing front access cover assembly hinges.

(2) Welding is to be carried out to EMER Wksp O 360 Chap 12, using a 3.25 mm rod.

(3) Before commencing with repair, remove front access cover from the vehicle.

1 Remove existing hull hinges by gas cutting or gouging to within 6 mm of armour plate. Avoid damaging protection strip.

2 Remove remaining metal by grinding. Avoid overheating of armour plate.

3 Finish smooth armour plate and protection strip and use NDT (penetrant dye) to establish that no surface cracks are present.

NOTE

If cracks are present a separate repair procedure will be required.

4 Replace weld removed from edge of protection strip during ops 1, 2 and 3 with a fillet weld as indicated on detail 'B'.

5 Locate front access cover on vehicle, set to 3.8 mm and clamp in position.

6 Set first hull hinge to 1.2 mm from first front access cover hinge and align holes centres using hinge pin (item 3). Make initial root weld along bottom edge of hinge and hull.

7 Set second hull hinge to 1.2 mm from second front access cover hinge and align holes using hinge pin (item 3). Make initial root weld along bottom edge of hinge and hull.

8 Check accuracy of hinge for position and squareness and use hinge pin (item 3) to ensure clearance when pivoting. See detail 'D'.

9 Unclamp front access cover and remove from vehicle.

10 Complete fillet welding of hull hinges as shown.

11 Replace weld removed from hull nose plates during ops 1, 2 and 3 with a fillet weld as indicated as detail 'C'.

12 Inspect.

13 After 72 hours, check that welds and plates are crack free.

14 Finish to Def Stan 03-32 Part 2, colour as per contract.

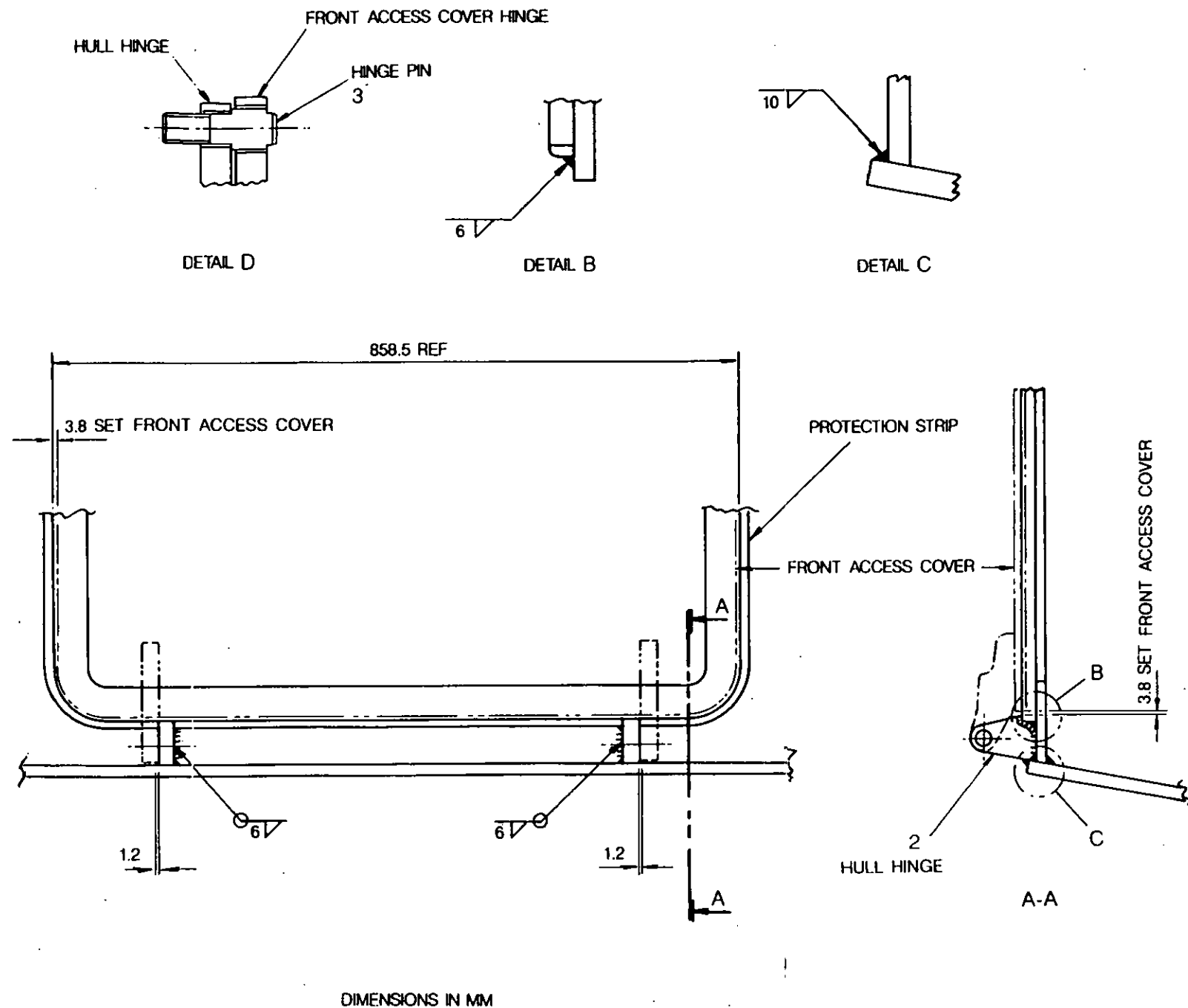

Fig 2 Replacement of the front access cover hinges (hull), set from the hatch hinges

V14677/2

NOTES

(1) This scheme is to be used when the hinges on hull and front access cover are to be replaced. Use this scheme to replace the hull hinges, followed by the scheme detailed at Fig 1, to replace the front access cover hinges.

(2) Welding is to be carried out to EMER Wksp O 360 Chap 12, using a 3.25 mm rod.

(3) Before commencing with repair, remove front access cover from the vehicle.

1 Remove existing hull hinges by gas cutting or gouging to within 6 mm of armour plate. Avoid damaging protection strip.

2 Remove remaining metal by grinding. Avoid overheating of armour plate.

3 Finish smooth armour plate and protection strip and use NDT (penetrant dye) to establish that no surface cracks are present.

NOTE

If cracks are present a separate repair procedure will be required.

4 Replace weld removed from edge of protection strip during ops 1, 2 and 3 with a fillet weld as indicated at detail 'B'.

5 Set first hinge to 125.7 mm from inside of protection strip and make initial root weld along bottom edge of hinge.

6 Check accuracy of hinge for position and squareness.

7 Complete fillet welding of hinge as shown.

8 Set second hinge to 607 mm and make initial root weld along bottom edge of hinge.

9 Check accuracy of hinge for position and squareness.

10 Complete fillet welding of hinge as shown.

11 Replace weld removed from hull nose plates during ops 1, 2 and 3 with a fillet weld as indicated at detail 'C'.

12 Inspect.

13 After 72 hours, check with NDT that welds and plates are crack free.

14 Finish to Def Stan 03-32 Part 2, colour as per contract.

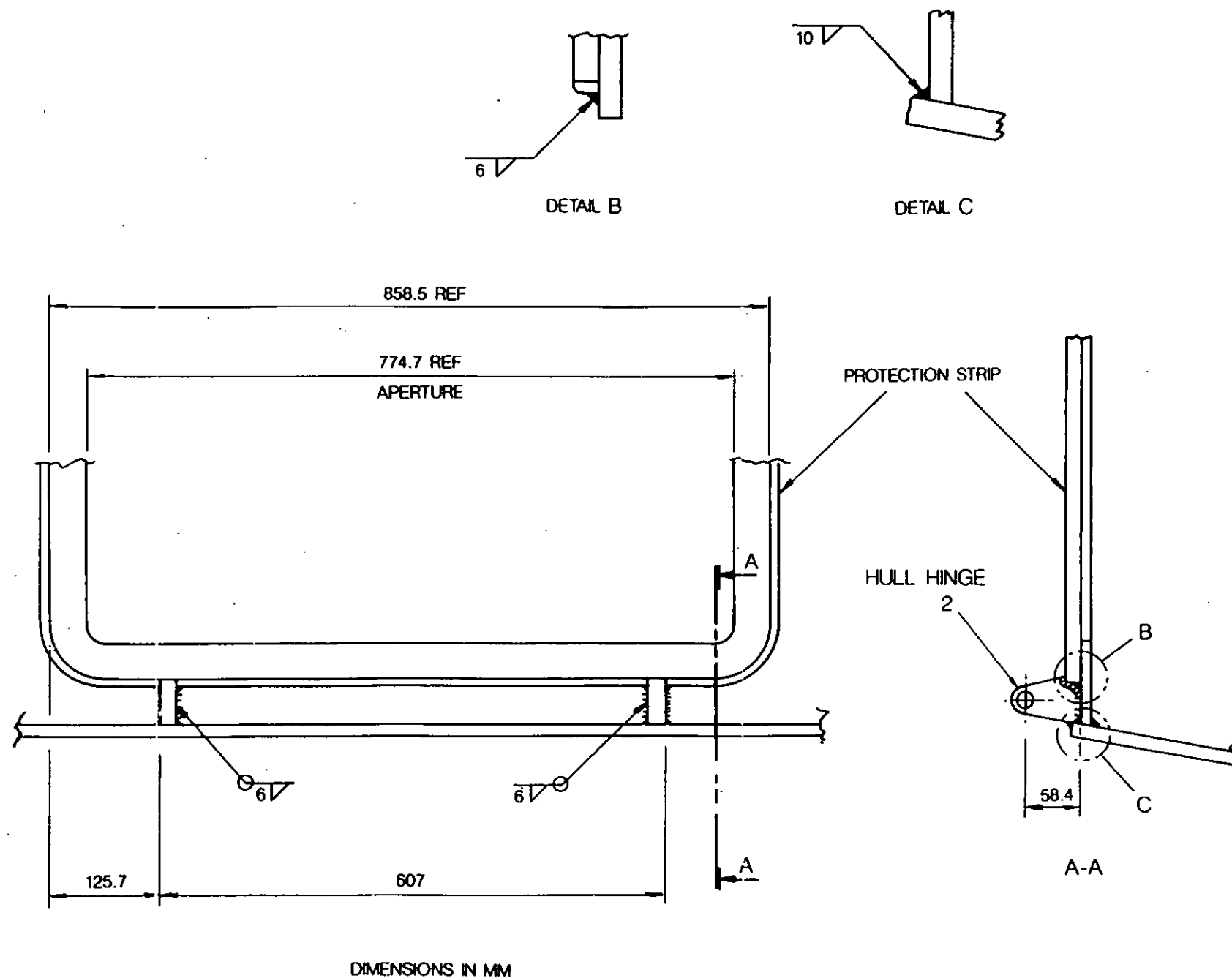

Fig 3 Replacement of the front access cover hinges (hull), set to the original build standard